

LM3103

SIMPLE SWITCHER® Synchronous 1MHz 0.75A Step-Down Voltage Regulator

General Description

The LM3103 Synchronously Rectified Buck Converter features all required functions to implement a highly efficient and cost effective buck regulator. It is capable of supplying 0.75A to loads with an output voltage as low as 0.6V. Dual N-Channel synchronous MOSFET switches allow a low component count, thus reducing complexity and minimizing board size.

Different from most other COT regulators, the LM3103 does not rely on output capacitor ESR for stability, and is designed to work exceptionally well with ceramic and other very low ESR output capacitors. It requires no loop compensation, results in a fast load transient response and simple circuit implementation. The operating frequency remains nearly constant with line variations due to the inverse relationship between the input voltage and the on-time. The operating frequency can be externally programmed up to 1 MHz. Protection features include V_{CC} under-voltage lock-out, output over-voltage protection, thermal shutdown, and gate drive under-voltage lock-out. The LM3103 is available in the thermally enhanced eTSSOP-16 package.

Key Specifications

- Input voltage range 4.5V-42V
- 0.75A output current
- 0.6V, $\pm 2\%$ reference
- Integrated dual N-Channel main and synchronous MOSFETs
- Thermally enhanced eTSSOP-16 package

Features

- Low component count and small solution size
- Stable with ceramic and other low ESR capacitors
- No loop compensation required
- High efficiency at a light load by DCM operation
- Pre-bias startup
- Ultra-fast transient response
- Programmable soft-start
- Programmable switching frequency up to 1 MHz
- Valley current limit
- Thermal shutdown
- Output over-voltage protection
- Precision internal reference for an adjustable output voltage down to 0.6V

Typical Applications

- 5VDC, 12VDC, 24VDC, 12VAC, and 24VAC systems
- Embedded Systems
- Industrial Control
- Automotive Telematics and Body Electronics
- Point of Load Regulators
- Storage Systems
- Broadband Infrastructure
- Direct Conversion from 2/3/4 Cell Lithium Batteries Systems

Typical Application

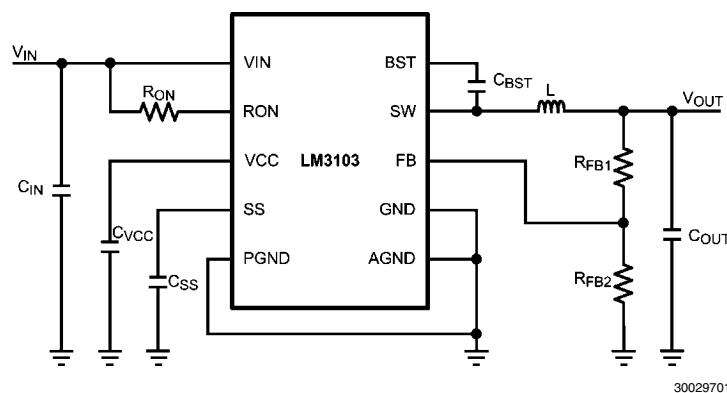

SIMPLE SWITCHER® is a registered trademark of National Semiconductor Corporation

Connection Diagram

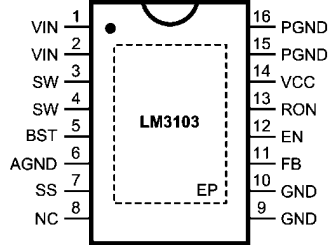

30029702
16-Lead Plastic eTSSOP
NS Package Number MXA16A

Ordering Information

Order Number	Package Type	NSC Package Drawing	Supplied As
LM3103MH	Exposed Pad TSSOP-16	MXA16A	92 units per Anti-Static Tube
LM3103MHX			2500 Units on Tape and Reel

Pin Descriptions

Pin	Name	Description	Application Information
1, 2	VIN	Input supply voltage	Supply pin to the device. Nominal input range is 4.5V to 42V.
3, 4	SW	Switch Node	Internally connected to the source of the main MOSFET and the drain of the synchronous MOSFET. Connect to the output inductor.
5	BST	Connection for bootstrap capacitor	Connect a 33 nF capacitor from the SW pin to this pin. This capacitor is charged through an internal diode during the main MOSFET off-time.
6	AGND	Analog Ground	Ground for all internal circuitry other than the PGND pin.
7	SS	Soft-start	A 70 μ A internal current source charges an external capacitor of larger than 22 nF to provide the soft-start function.
8	NC	No Connection	This pin should be left unconnected.
9, 10	GND	Ground	Must be connected to the AGND pin for normal operation. The GND and AGND pins are not internally connected.
11	FB	Feedback	Internally connected to the regulation and over-voltage comparators. The regulation setting is 0.6V at this pin. Connect to feedback resistors.
12	EN	Enable pin	Internal pull-up. Connect to a voltage higher than 1.6V to enable the device.
13	RON	On-time Control	An external resistor from the VIN pin to this pin sets the main MOSFET on-time.
14	VCC	Startup regulator Output	Nominally regulated to 6V. Connect a capacitor of larger than 1 μ F between the VCC and AGND pins for stable operation.
15, 16	PGND	Power Ground	Synchronous MOSFET source connection. Tie to a ground plane.
DAP	EP	Exposed Pad	Thermal connection pad. Connect to the ground plane.

Absolute Maximum Ratings (Note 1)

If Military/Aerospace specified devices are required, please contact the National Semiconductor Sales Office/ Distributors for availability and specifications.

VIN, RON to AGND	-0.3V to 43.5V
SW to AGND	-0.3V to 43.5V
SW to AGND (Transient)	-2V (< 100ns)
VIN to SW	-0.3V to 43.5V
BST to SW	-0.3V to 7V
VCC to AGND	-0.3V to 7V
FB to AGND	-0.3V to 5V

All Other Inputs to AGND	-0.3V to 7V
ESD Rating (Note 2)	
Human Body Model	±2kV
Storage Temperature Range	-65°C to +150°C
Junction Temperature (T _J)	150°C

Operating Ratings (Note 1)

Supply Voltage Range (VIN)	4.5V to 42V
Junction Temperature Range (T _J)	-40°C to +125°C
Thermal Resistance (θ _{JA}) (Note 3)	35°C/W

Electrical Characteristics Specifications with standard type are for T_J = 25°C only; limits in **boldface type** apply over the full Operating Junction Temperature (T_J) range. Minimum and Maximum limits are guaranteed through test, design, or statistical correlation. Typical values represent the most likely parametric norm at T_J = 25°C, and are provided for reference purposes only. Unless otherwise stated the following conditions apply: V_{IN} = 18V, V_{OUT} = 3.3V.

Symbol	Parameter	Conditions	Min	Typ	Max	Units
Start-Up Regulator, V_{CC}						
V _{CC}	V _{CC} output voltage	C _{VCC} = 1 μF, no load	5.6	6.0	6.2	V
V _{IN} - V _{CC}	V _{IN} - V _{CC} dropout voltage (Note 4)	I _{CC} = 2mA		55	150	mV
		I _{CC} = 10mA		235	500	
V _{CC-UVLO}	V _{CC} under-voltage lockout threshold (UVLO)	V _{IN} increasing	3.5	3.7	4.1	V
V _{CC-UVLO-HYS}	V _{CC} UVLO hysteresis	V _{IN} decreasing		275		mV
I _{IN}	I _{IN} operating current	No switching, V _{FB} = 1V		1.0	1.25	mA
I _{IN-SD}	I _{IN} operating current, Device shutdown	V _{EN} = 0V		20	40	μA
I _{VCC}	V _{CC} current limit	V _{CC} = 0V	20	33	42	mA
Switching Characteristics						
R _{DS-UP-ON}	Main MOSFET R _{DS(on)}			0.370	0.7	Ω
R _{DS-DN-ON}	Syn. MOSFET R _{DS(on)}			0.220	0.4	Ω
Soft-start						
I _{SS}	SS pin source current	V _{SS} = 0V	45	70	95	μA
Current Limit						
I _{CL}	Syn. MOSFET current limit threshold			0.9		A
ON/OFF Timer						
t _{on}	ON timer pulse width	V _{IN} = 10V, R _{ON} = 33 kΩ		0.350		μs
		V _{IN} = 18V, R _{ON} = 33 kΩ		0.170		
t _{on-MIN}	ON timer minimum pulse width			100		ns
t _{off}	OFF timer pulse width			240		ns
Enable Input						
V _{EN}	EN Pin input threshold	V _{EN} rising		1.6	1.85	V
V _{EN-HYS}	Enable threshold hysteresis	V _{EN} falling		230		mV
I _{EN}	Enable Pull-up Current	V _{EN} = 0V		1		μA
Regulation and Over-Voltage Comparator						
V _{FB}	In-regulation feedback voltage	T _J = -40°C to +125°C	0.588	0.6	0.612	V
V _{FB-OV}	Feedback over-voltage threshold		0.655	0.680	0.705	V
I _{FB}				1		nA

Symbol	Parameter	Conditions	Min	Typ	Max	Units
Thermal Shutdown						
T_{SD}	Thermal shutdown temperature	T_J rising		165		$^{\circ}C$
T_{SD-HYS}	Thermal shutdown temperature hysteresis	T_J falling		20		$^{\circ}C$

Note 1: Absolute Maximum Ratings are limits beyond which damage to the device may occur. Operating Ratings are conditions under which operation of the device is intended to be functional. For guaranteed specifications and test conditions, see the Electrical Characteristics.

Note 2: The human body model is a 100pF capacitor discharged through a 1.5k Ω resistor into each pin.

Note 3: θ_{JA} measurements were performed in general accordance with JEDEC Standards JESD51-1 to JESD51-11.

Note 4: V_{CC} provides self bias for the internal gate drive and control circuits. Device thermal limitations limit external loading.

Typical Performance Characteristics

All curves are taken at $V_{IN} = 18V$ with the configuration in the typical application circuit for $V_{OUT} = 3.3V$ shown in this datasheet. $T_A = 25^\circ C$, unless otherwise specified.

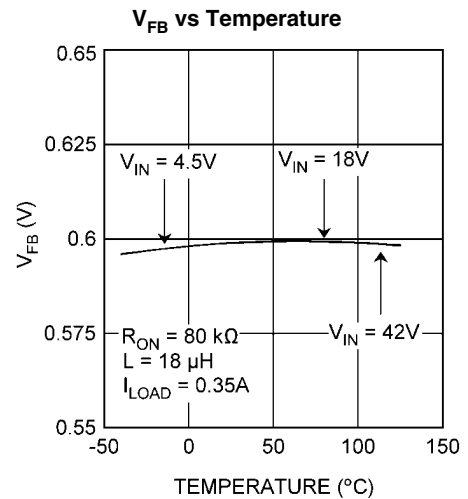
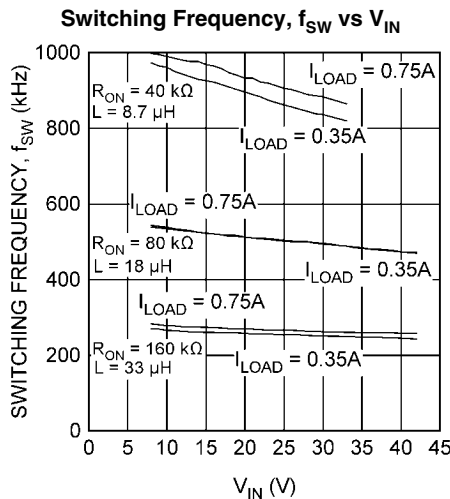
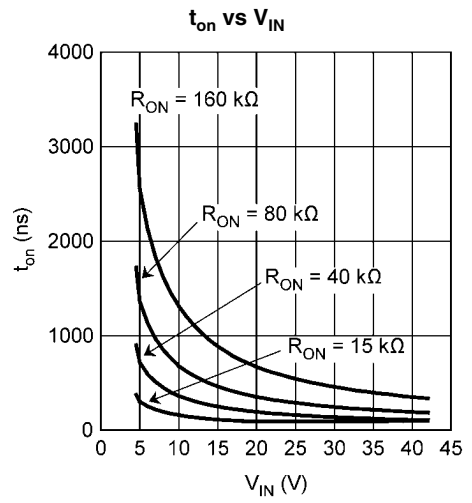
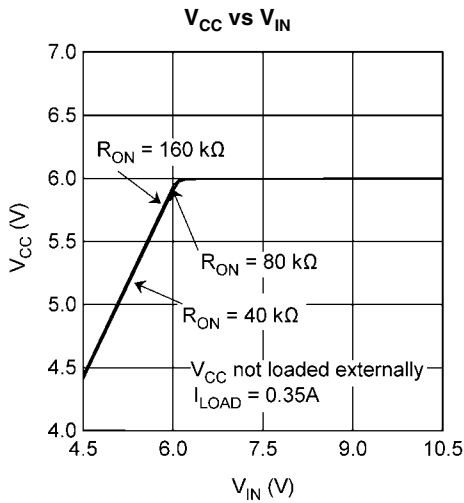
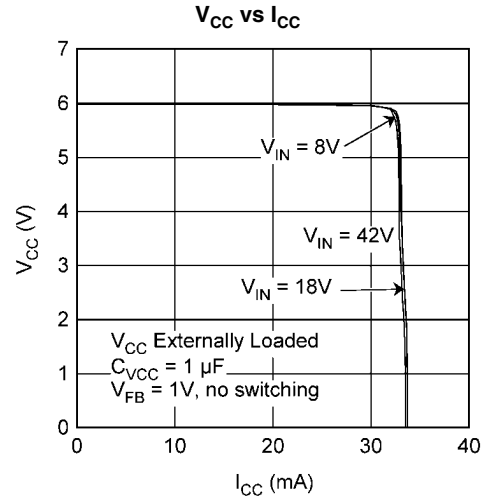
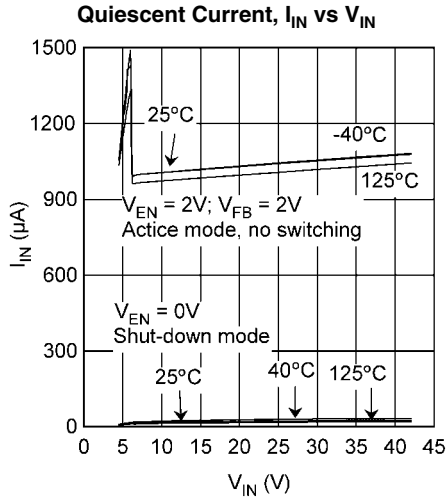

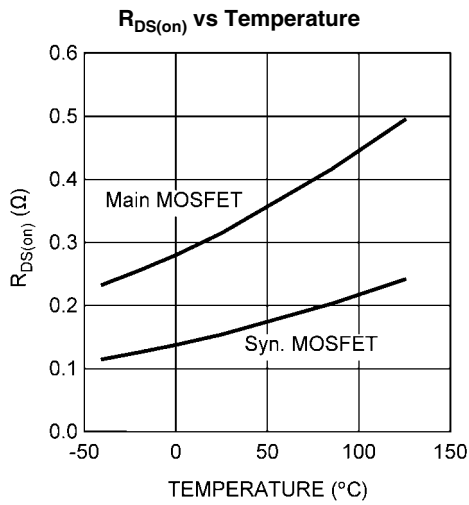

30029709

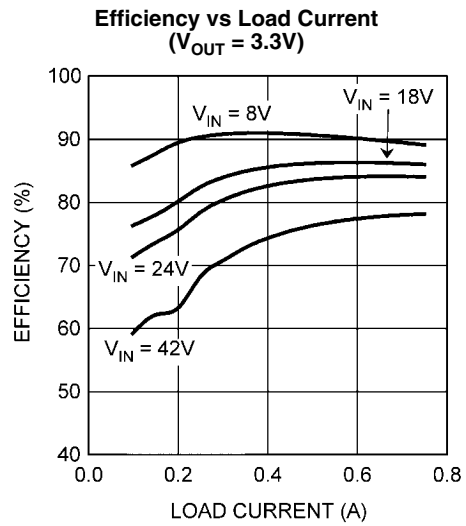

30029710

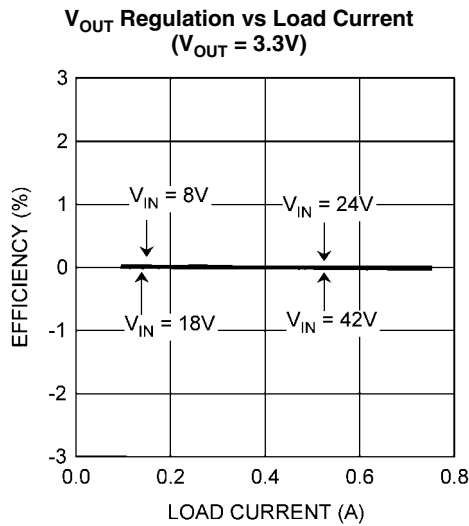

30029711

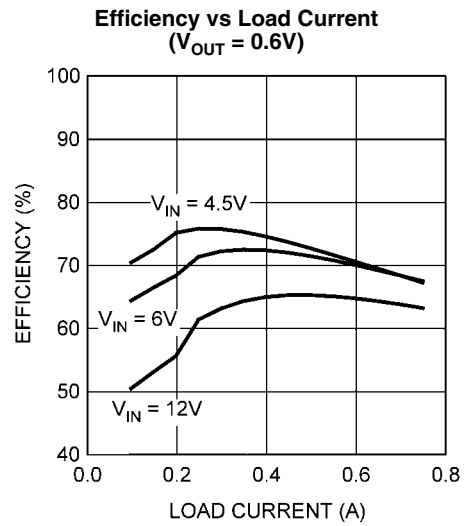

30029712

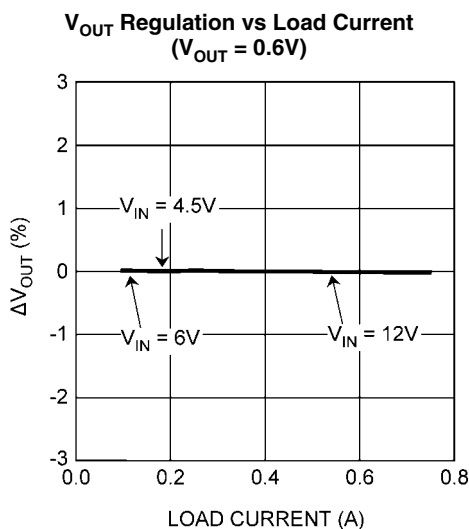

30029713

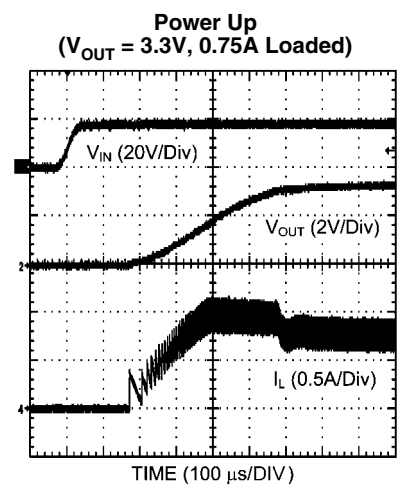

30029714

Enable Transient
 ($V_{OUT} = 3.3V, 0.75A$ Loaded)

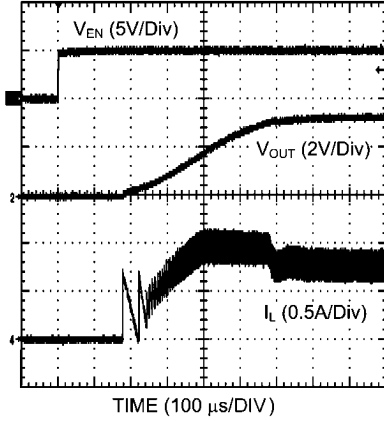

30029715

Shutdown Transient
 ($V_{OUT} = 3.3V, 0.75A$ Loaded)

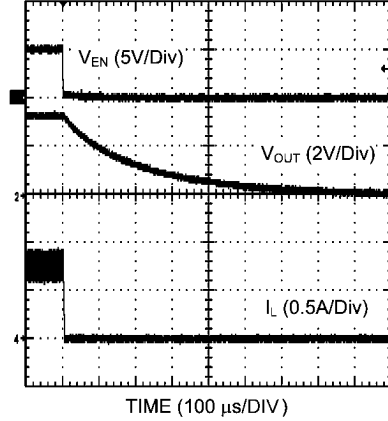

30029716

Continuous Mode Operation
 ($V_{OUT} = 3.3V, 2.5A$ Loaded)

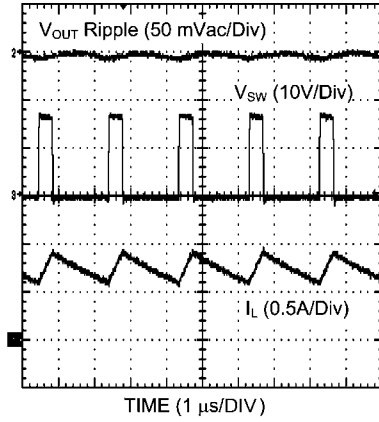

30029717

Discontinuous Mode Operation
 ($V_{OUT} = 3.3V, 0.02A$ Loaded)

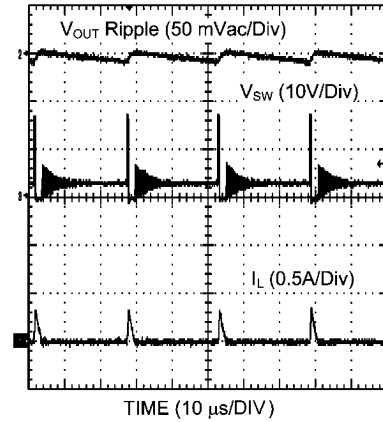

30029718

DCM to CCM Transition
 ($V_{OUT} = 3.3V, 0.01A - 0.75A$ Load)

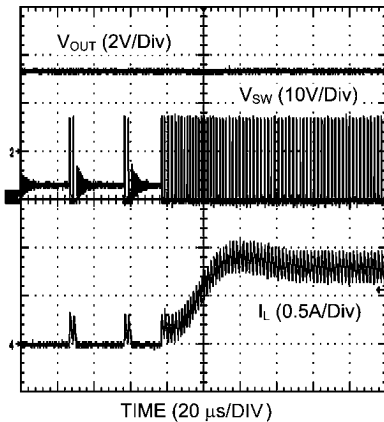

30029719

Load Transient
 ($V_{OUT} = 3.3V, 0.075A - 0.75A$ Load, Current slew-rate: $2.5A/\mu s$)

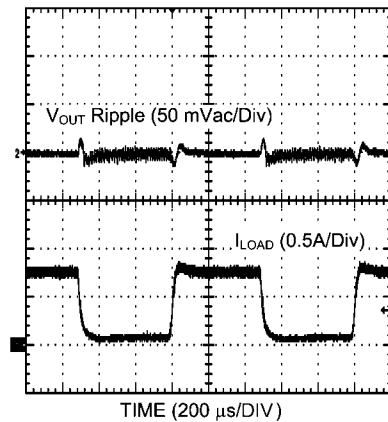

30029720

Simplified Functional Block Diagram

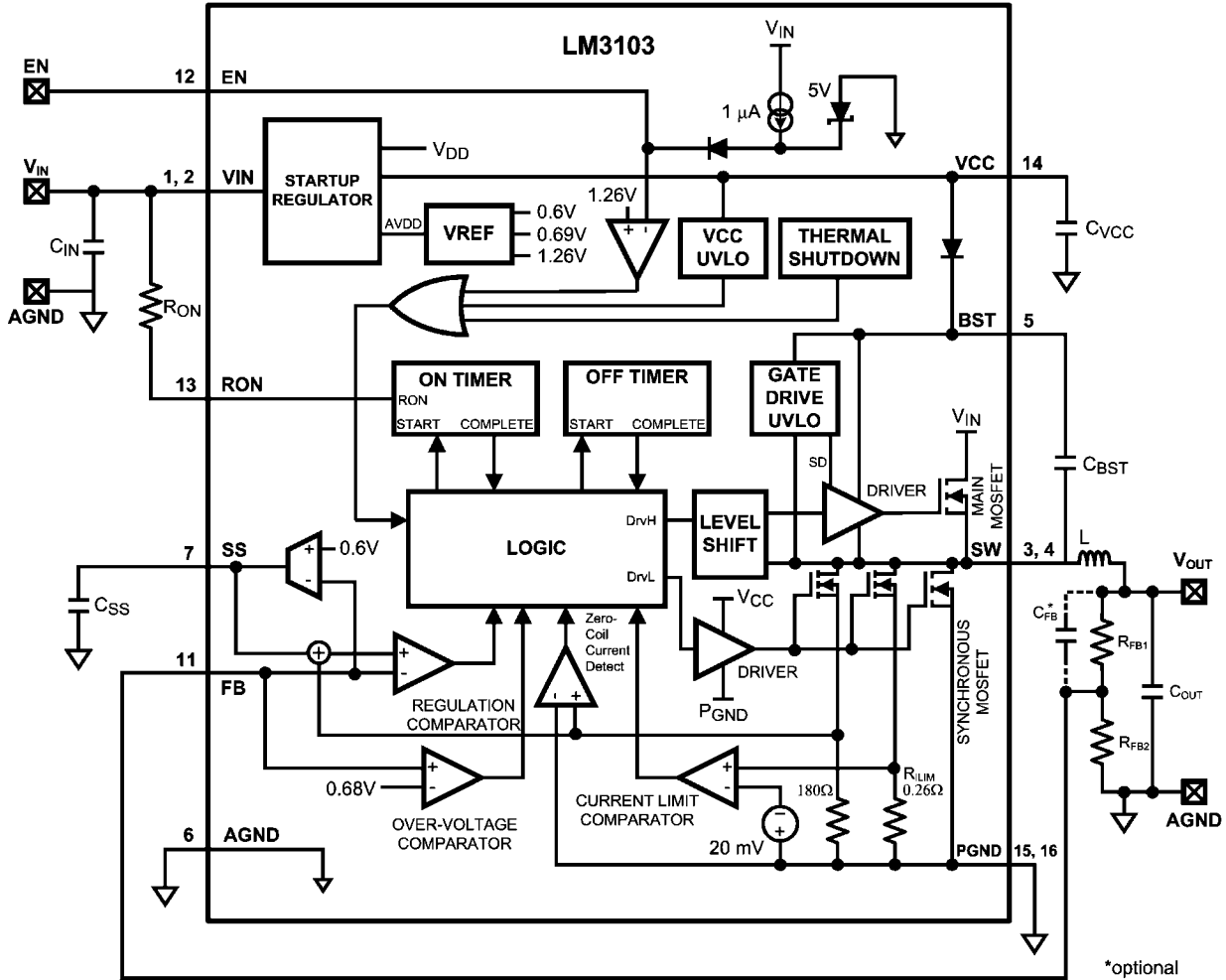

*optional

30029721

Functional Description

The LM3103 Step Down Switching Regulator features all required functions to implement a cost effective, efficient buck power converter which is capable of supplying 0.75A to loads. It contains dual N-Channel main and synchronous MOSFETs. The Constant ON-Time (COT) regulation scheme requires no loop compensation, results in a fast load transient response and simple circuit implementation. The regulator can function properly even with an all ceramic output capacitor network, and does not rely on the output capacitor's ESR for stability. The operating frequency remains constant with line variations due to the inverse relationship between the input voltage and the on-time. The valley current limit detection circuit, with a limit set internally at 0.9A, inhibits the main MOSFET until the inductor current level subsides.

The LM3103 can be applied in numerous applications and can operate efficiently for inputs as high as 42V. Protection features include V_{CC} under-voltage lockout, output over-voltage protection, thermal shutdown, gate drive under-voltage lock-out. The LM3103 is available in the thermally enhanced eTSSOP-16 package.

COT Control Circuit Overview

COT control is based on a comparator and a one-shot timer, with the output voltage feedback (feeding to the FB pin) compared with a 0.6V internal reference. If the voltage of the FB pin is below the reference, the main MOSFET is turned on for a fixed on-time determined by a programming resistor R_{ON} and the input voltage V_{IN} , upon which the on-time varies inversely. Following the on-time, the main MOSFET remains off for a minimum of 240 ns. Then, if the voltage of the FB pin is below the reference, the main MOSFET is turned on again for another on-time period. The switching will continue to achieve regulation.

The regulator will operate in the discontinuous conduction mode (DCM) at a light load, and the continuous conduction mode (CCM) with a heavy load. In the DCM, the current through the inductor starts at zero and ramps up to a peak during the on-time, and then ramps back to zero before the end of the off-time. It remains zero and the load current is supplied entirely by the output capacitor. The next on-time period starts when the voltage at the FB pin falls below the internal reference. The operating frequency in the DCM is lower and varies larger with the load current as compared with the CCM. Conversion efficiency is maintained since conduction loss and switching loss are reduced with the reduction in the load and the switching frequency respectively. The operating frequency in the DCM can be calculated approximately as follows:

$$f_{SW} = \frac{V_{OUT} (V_{IN} - 1) \times L \times 1.18 \times 10^{20} \times I_{OUT}}{(V_{IN} - V_{OUT}) \times R_{ON}^2} \quad (1)$$

In the continuous conduction mode (CCM), the current flows through the inductor in the entire switching cycle, and never reaches zero during the off-time. The operating frequency remains relatively constant with load and line variations. The CCM operating frequency can be calculated approximately as follows:

$$f_{SW} = \frac{V_{OUT}}{8.3 \times 10^{-11} \times R_{ON}} \quad (2)$$

The output voltage is set by two external resistors R_{FB1} and R_{FB2} . The regulated output voltage is

$$V_{OUT} = 0.6V \times (R_{FB1} + R_{FB2})/R_{FB2} \quad (3)$$

Startup Regulator (V_{CC})

A startup regulator is integrated within the LM3103. The input pin V_{IN} can be connected directly to a line voltage up to 42V. The V_{CC} output regulates at 6V, and is current limited to 30 mA. Upon power up, the regulator sources current into an external capacitor C_{VCC} , which is connected to the VCC pin. For stability, C_{VCC} must be at least 1 μ F. When the voltage on the VCC pin is higher than the under-voltage lock-out (UVLO) threshold of 3.7V, the main MOSFET is enabled and the SS pin is released to allow the soft-start capacitor C_{SS} to charge.

The minimum input voltage is determined by the dropout voltage of the regulator and the V_{CC} UVLO falling threshold ($\approx 3.4V$). If V_{IN} is less than $\approx 4.0V$, the regulator shuts off and V_{CC} goes to zero.

Regulation Comparator

The feedback voltage at the FB pin is compared to a 0.6V internal reference. In normal operation (the output voltage is regulated), an on-time period is initiated when the voltage at the FB pin falls below 0.6V. The main MOSFET stays on for the programmed on-time, causing the output voltage to rise and consequently the voltage of the FB pin to rise above 0.6V. After the on-time period, the main MOSFET stays off until the voltage of the FB pin falls below 0.6V again. Bias current at the FB pin is nominally 1 nA.

Zero Coil Current Detect

The current of the synchronous MOSFET is monitored by a zero coil current detection circuit which inhibits the synchronous MOSFET when its current reaches zero until the next on-time. This circuit enables the DCM operation, which improves the efficiency at a light load.

Over-Voltage Comparator

The voltage at the FB pin is compared to a 0.68V internal reference. If it rises above 0.68V, the on-time is immediately terminated. This condition is known as over-voltage protection (OVP). It can occur if the input voltage or the output load changes suddenly. Once the OVP is activated, the main MOSFET remains off until the voltage at the FB pin falls below 0.6V. The synchronous MOSFET will stay on to discharge the inductor until the inductor current reduces to zero and then switch off.

ON-Time Timer, Shutdown

The on-time of the LM3103 main MOSFET is determined by the resistor R_{ON} and the input voltage V_{IN} . It is calculated as follows:

$$t_{ON} = \frac{8.3 \times 10^{-11} \times R_{ON}}{V_{IN}} \quad (4)$$

The inverse relationship of t_{on} and V_{IN} gives a nearly constant frequency as V_{IN} is varied. R_{ON} should be selected such that the on-time at maximum V_{IN} is greater than 100 ns. The on-timer has a limiter to ensure a minimum of 100 ns for t_{on} . This limits the maximum operating frequency, which is governed by the following equation:

$$f_{SW(MAX)} = \frac{V_{OUT}}{V_{IN(MAX)} \times 100 \text{ ns}} \quad (5)$$

The LM3103 can be remotely shut down by pulling the voltage of the EN pin below 1.6V. In this shutdown mode, the SS pin is internally grounded, the on-timer is disabled, and bias currents are reduced. Releasing the EN pin allows normal operation to resume because the EN pin is internally pulled up.

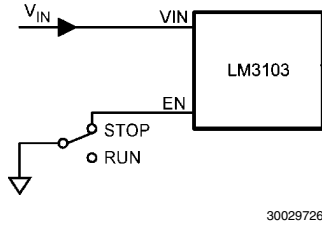

30029726

FIGURE 1. Shutdown Implementation

Current Limit

Current limit detection is carried out during the off-time by monitoring the re-circulating current through the synchronous MOSFET. Referring to the Functional Block Diagram, when

the main MOSFET is turned off, the inductor current flows through the load, the PGND pin and the internal synchronous MOSFET. If this current exceeds 0.9A, the current limit comparator toggles, and as a result the start of the next on-time period is disabled. The next switching cycle starts when the re-circulating current falls back below 0.9A (and the voltage at the FB pin is below 0.6V). The inductor current is monitored during the on-time of the synchronous MOSFET. As long as the inductor current exceeds 0.9A, the main MOSFET will remain inhibited to achieve current limit. The operating frequency is lower during current limit owing to a longer off-time.

Figure 2 illustrates an inductor current waveform. On average, the output current I_{OUT} is the same as the inductor current I_L , which is the average of the rippled inductor current. In case of current limit (the current limit portion of Figure 2), the next on-time will not initiate until that the current drops below 0.9A (assume the voltage at the FB pin is lower than 0.6V). During each on-time the current ramps up an amount equal to:

$$I_{LR} = \frac{(V_{IN} - V_{OUT}) \times t_{on}}{L} \quad (6)$$

During current limit, the LM3103 operates in a constant current mode with an average output current $I_{OUT(CL)}$ equal to $0.9A + I_{LR} / 2$.

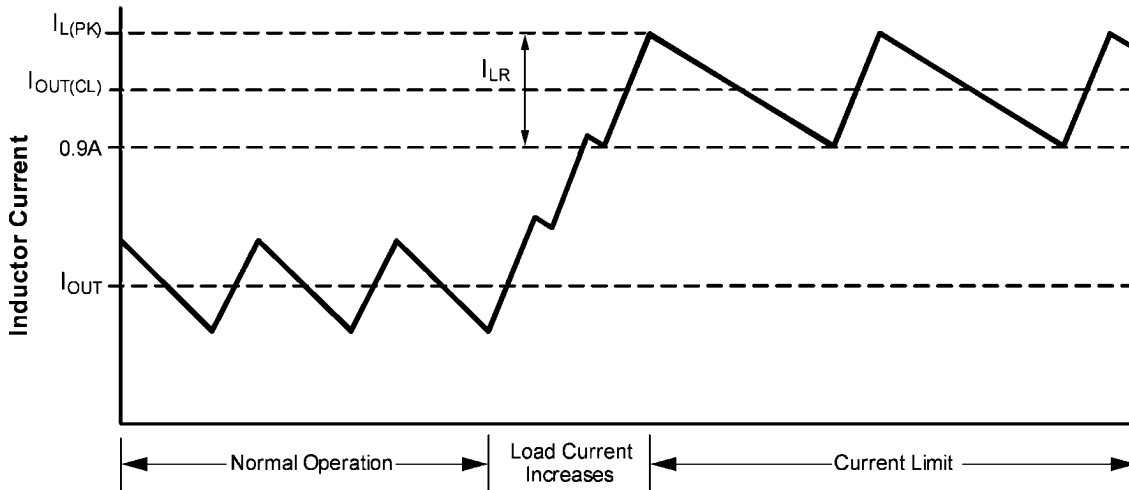

30029728

FIGURE 2. Inductor Current - Current Limit Operation

N-Channel MOSFET and Driver

The LM3103 integrates an N-Channel main MOSFET and an associated floating high voltage main MOSFET gate driver. The gate drive circuit works in conjunction with an external bootstrap capacitor C_{BST} and an internal high voltage diode. C_{BST} connected between the BST and SW pins powers the main MOSFET gate driver during the main MOSFET on-time. During each off-time, the voltage of the SW pin falls to approximately -1V, and C_{BST} charges from V_{CC} through the internal diode. The minimum off-time of 240 ns provides enough time for charging C_{BST} in each cycle.

Soft-Start

The soft-start feature allows the converter to gradually reach a steady state operating point, thereby reducing startup stresses and current surges. Upon turn-on, after V_{CC} reaches the under-voltage threshold and a 180 μ s fixed delay, a 70 μ A internal current source charges an external capacitor C_{SS} connecting to the SS pin. The ramping voltage at the SS pin (and the non-inverting input of the regulation comparator as well) ramps up the output voltage V_{OUT} in a controlled manner. An internal switch grounds the SS pin if any of the following three cases happen: (i) V_{CC} is below the under-voltage lockout threshold; (ii) a thermal shutdown occurs; or (iii) the EN pin is grounded. Alternatively, the output voltage can be shut off by connecting the SS pin to the ground using an external switch. Releasing the switch allows the voltage of the SS pin to ramp up and the output voltage to return to normal. The shutdown configuration is shown in Figure 3.

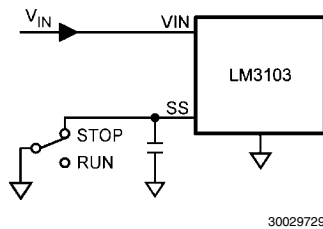

FIGURE 3. Alternate Shutdown Implementation

Thermal Protection

The junction temperature of the LM3103 should not exceed the maximum limit. Thermal protection is implemented by an internal Thermal Shutdown circuit, which activates (typically) at 165°C to make the controller enter a low power reset state by disabling the main MOSFET, disabling the on-timer, and grounding the SS pin. Thermal protection helps prevent catastrophic failures from accidental device overheating. When the junction temperature falls back below 145°C (typical hysteresis = 20°C), the SS pin is released and normal operation resumes.

Applications Information

EXTERNAL COMPONENTS

The following guidelines can be used to select external components.

R_{FB1} and R_{FB2} : These resistors should be chosen from standard values in the range of 1.0 k Ω to 10 k Ω , satisfying the following ratio:

$$R_{FB1}/R_{FB2} = (V_{OUT}/0.6V) - 1 \quad (7)$$

For $V_{OUT} = 0.6V$, the FB pin can be connected to the output directly with a pre-load resistor drawing more than 20 μ A. This is because the converter operation needs a minimum inductor current ripple to maintain good regulation when no load is connected.

R_{ON} : Equation (2) can be used to select R_{ON} if a desired operating frequency is selected. But the minimum value of R_{ON} is determined by the minimum on-time. It can be calculated as follows:

$$R_{ON} \geq \frac{V_{IN(MAX)} \times 100 \text{ ns}}{8.3 \times 10^{-11}} \quad (8)$$

If R_{ON} calculated from (2) is smaller than the minimum value determined in (8), a lower frequency should be selected to recalculate R_{ON} by (2). Alternatively, $V_{IN(MAX)}$ can also be limited in order to keep the frequency unchanged. The relationship of $V_{IN(MAX)}$ and R_{ON} is shown in Figure 4.

On the other hand, the minimum off-time of 240 ns can limit the maximum duty ratio. This may be significant at low V_{IN} . A larger R_{ON} should be selected in any application requiring a large duty ratio.

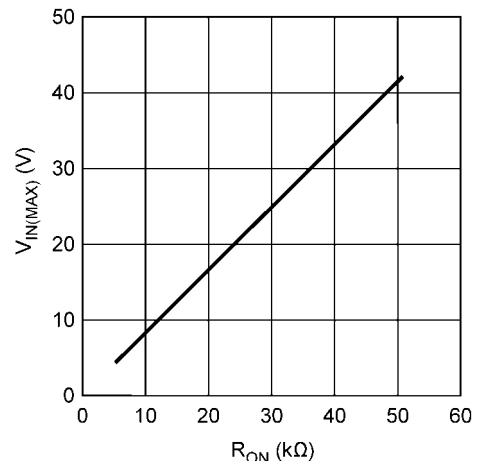

30029738

FIGURE 4. Maximum V_{IN} for selected R_{ON}

L: The main parameter affected by the inductor is the amplitude of the inductor current ripple (I_{LR}), which is recommended to be greater than 0.3A. Once I_{LR} is selected, L can be determined by:

$$L = \frac{V_{OUT} \times (V_{IN} - V_{OUT})}{I_{LR} \times f_{SW} \times V_{IN}} \quad (9)$$

where V_{IN} is the input voltage and f_{SW} is determined from (2).

If the output current I_{OUT} is known, by assuming that $I_{OUT} = I_L$, the peak and valley of I_{LR} can be determined. Beware that the peak of I_{LR} should not be larger than the saturation current of the inductor and the current rating of the main and synchronous MOSFETs. Also, the valley of I_{LR} must be positive if CCM operation is required.

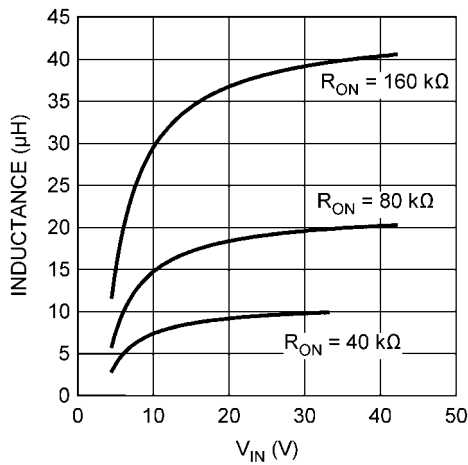

30029732

FIGURE 5. Inductor selection for $V_{OUT} = 3.3V$

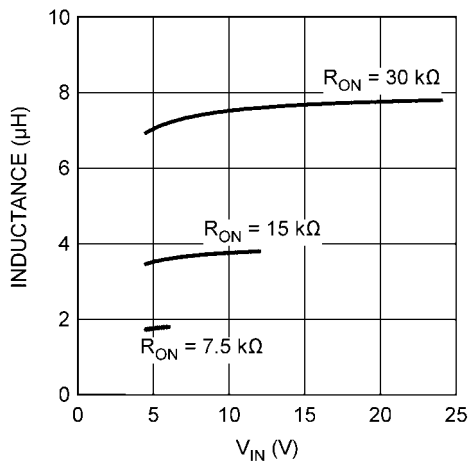

30029733

FIGURE 6. Inductor selection for $V_{OUT} = 0.6V$

Figures 5 and 6 show curves on inductor selection for various V_{OUT} and R_{ON} . According to (8), V_{IN} is limited for small R_{ON} . Some curves are therefore limited as shown in the figures.

C_{VCC} : The capacitor on the V_{CC} output provides not only noise filtering and stability, but also prevents false triggering of the V_{CC} UVLO at the main MOSFET on/off transitions. C_{VCC} should be no smaller than $1 \mu F$ for stability, and should be a good quality, low ESR, ceramic capacitor.

C_{OUT} and C_{OUT3} : C_{OUT} should generally be no smaller than $10 \mu F$. Experimentation is usually necessary to determine the minimum value for C_{OUT} , as the nature of the load may require a larger value. A load which creates significant transients requires a larger C_{OUT} than a fixed load.

C_{OUT3} is a small value ceramic capacitor located close to the LM3103 to further suppress high frequency noise at V_{OUT} . A 47 nF capacitor is recommended.

C_{IN} and C_{IN3} : The function of C_{IN} is to supply most of the main MOSFET current during the on-time, and limit the voltage ripple at the VIN pin, assuming that the voltage source connecting to the VIN pin has finite output impedance. If the voltage source's dynamic impedance is high (effectively a current source), C_{IN} supplies the difference between the instantaneous input current and the average input current.

At the maximum load current, when the main MOSFET turns on, the current to the VIN pin suddenly increases from zero to the valley of the inductor's ripple current and ramps up to the peak value. It then drops to zero at turn-off. The average current during the on-time is the load current. For a worst case calculation, C_{IN} must be capable of supplying this average load current during the maximum on-time. C_{IN} is calculated from:

$$C_{IN} = \frac{I_{OUT} \times t_{ON}}{\Delta V_{IN}} \quad (10)$$

where I_{OUT} is the load current, t_{on} is the maximum on-time, and ΔV_{IN} is the allowable ripple voltage at V_{IN} .

C_{IN3} 's purpose is to help avoid transients and ringing due to long lead inductance at the VIN pin. A low ESR $0.1 \mu F$ ceramic chip capacitor located close to the LM3103 is recommended.

C_{BST} : A 33 nF high quality ceramic capacitor with low ESR is recommended for C_{BST} since it supplies a surge current to charge the main MOSFET gate driver at each turn-on. Low ESR also helps ensure a complete recharge during each off-time.

C_{SS} : The capacitor at the SS pin determines the soft-start time, i.e. the time for the reference voltage at the regulation comparator and therefore, the output voltage to reach their final value. The time is determined from the following equation:

$$t_{SS} = 180 \mu s + \frac{C_{SS} \times 0.6V}{70 \mu A} \quad (11)$$

C_{FB} : If the output voltage is higher than $1.6V$, C_{FB} is needed in the Discontinuous Conduction Mode to reduce the output ripple. The recommended value for C_{FB} is 10 nF .

PC BOARD LAYOUT

The LM3103 regulation, over-voltage, and current limit comparators are very fast so they will respond to short duration noise pulses. Layout is therefore critical for optimum performance. It must be as neat and compact as possible, and all external components must be as close to their associated pins of the LM3103 as possible. Refer to the functional block diagram. The loop formed by C_{IN} , the main and synchronous MOSFET internal to the LM3103, and the PGND pin should be as small as possible. The connection from the PGND pin to C_{IN} should be as short and direct as possible. Vias should be added to connect the ground of C_{IN} to a ground plane, located as close to the capacitor as possible. The bootstrap capacitor C_{BST} should be connected as close to the SW and BST pins as possible, and the connecting traces should be thick. The feedback resistors and capacitor R_{FB1} , R_{FB2} , and C_{FB} should be close to the FB pin. A long trace running from V_{OUT} to R_{FB1} is generally acceptable since this is a low impedance node. Ground R_{FB2} directly to the AGND pin (pin 7). The output capacitor C_{OUT} should be connected close to the load and tied directly to the ground plane. The inductor L should be connected close to the SW pin with as short a trace as possible to reduce the potential for EMI (electromagnetic interference) generation. If it is expected that the internal dis-

sipation of the LM3103 will produce excessive junction temperature during normal operation, making good use of the PC board's ground plane can help considerably to dissipate heat. The exposed pad on the bottom of the LM3103 IC package can be soldered to the ground plane, which should extend out from beneath the LM3103 to help dissipate heat. The exposed pad is internally connected to the LM3103 IC substrate. Ad-

ditionally the use of thick traces, where possible, can help conduct heat away from the LM3103. Using numerous vias to connect the die attached pad to the ground plane is a good practice. Judicious positioning of the PC board within the end product, along with the use of any available air flow (forced or natural convection) can help reduce the junction temperature.

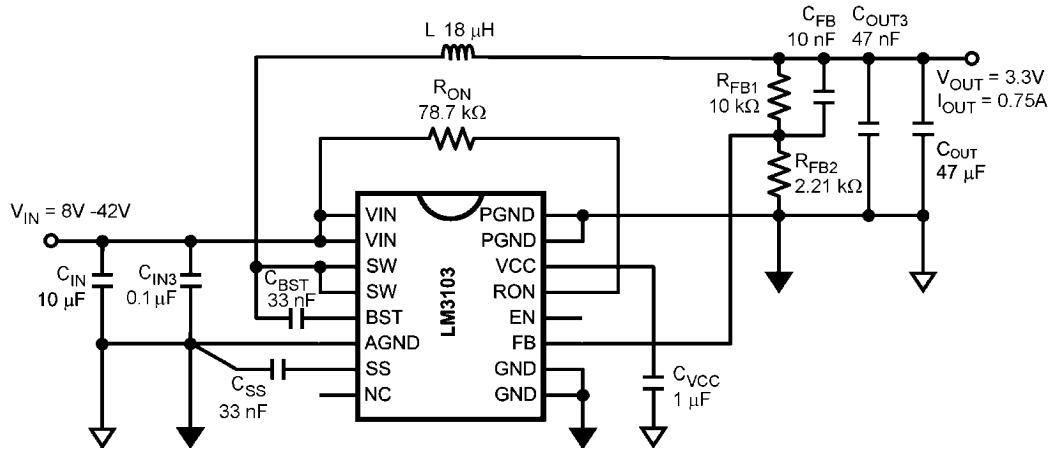

Typical Application Schematic for $V_{OUT} = 3.3V$

30029736

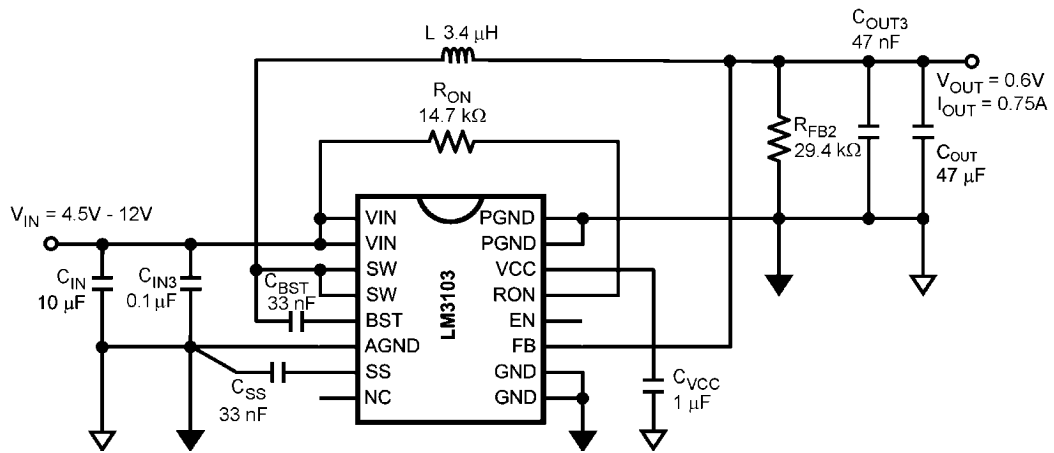

Typical Application Schematic for $V_{OUT} = 0.6V$

30029737

Physical Dimensions inches (millimeters) unless otherwise noted

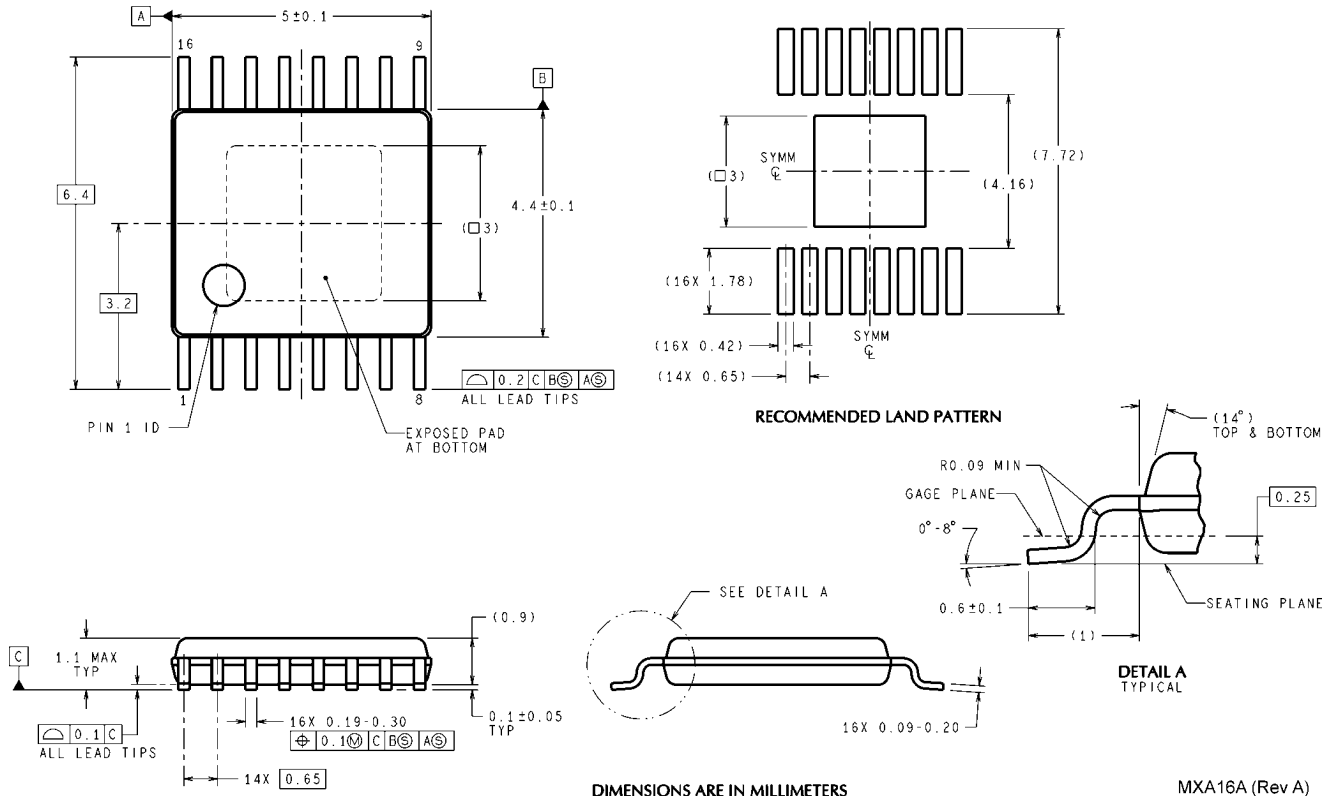

DIMENSIONS ARE IN MILLIMETERS
16-Lead Plastic eTSSOP Package
NS Package Number MXA16A

MXA16A (Rev A)

Notes

THE CONTENTS OF THIS DOCUMENT ARE PROVIDED IN CONNECTION WITH NATIONAL SEMICONDUCTOR CORPORATION ("NATIONAL") PRODUCTS. NATIONAL MAKES NO REPRESENTATIONS OR WARRANTIES WITH RESPECT TO THE ACCURACY OR COMPLETENESS OF THE CONTENTS OF THIS PUBLICATION AND RESERVES THE RIGHT TO MAKE CHANGES TO SPECIFICATIONS AND PRODUCT DESCRIPTIONS AT ANY TIME WITHOUT NOTICE. NO LICENSE, WHETHER EXPRESS, IMPLIED, ARISING BY ESTOPPEL OR OTHERWISE, TO ANY INTELLECTUAL PROPERTY RIGHTS IS GRANTED BY THIS DOCUMENT.

TESTING AND OTHER QUALITY CONTROLS ARE USED TO THE EXTENT NATIONAL DEEMS NECESSARY TO SUPPORT NATIONAL'S PRODUCT WARRANTY. EXCEPT WHERE MANDATED BY GOVERNMENT REQUIREMENTS, TESTING OF ALL PARAMETERS OF EACH PRODUCT IS NOT NECESSARILY PERFORMED. NATIONAL ASSUMES NO LIABILITY FOR APPLICATIONS ASSISTANCE OR BUYER PRODUCT DESIGN. BUYERS ARE RESPONSIBLE FOR THEIR PRODUCTS AND APPLICATIONS USING NATIONAL COMPONENTS. PRIOR TO USING OR DISTRIBUTING ANY PRODUCTS THAT INCLUDE NATIONAL COMPONENTS, BUYERS SHOULD PROVIDE ADEQUATE DESIGN, TESTING AND OPERATING SAFEGUARDS.

EXCEPT AS PROVIDED IN NATIONAL'S TERMS AND CONDITIONS OF SALE FOR SUCH PRODUCTS, NATIONAL ASSUMES NO LIABILITY WHATSOEVER, AND NATIONAL DISCLAIMS ANY EXPRESS OR IMPLIED WARRANTY RELATING TO THE SALE AND/OR USE OF NATIONAL PRODUCTS INCLUDING LIABILITY OR WARRANTIES RELATING TO FITNESS FOR A PARTICULAR PURPOSE, MERCHANTABILITY, OR INFRINGEMENT OF ANY PATENT, COPYRIGHT OR OTHER INTELLECTUAL PROPERTY RIGHT.

LIFE SUPPORT POLICY

NATIONAL'S PRODUCTS ARE NOT AUTHORIZED FOR USE AS CRITICAL COMPONENTS IN LIFE SUPPORT DEVICES OR SYSTEMS WITHOUT THE EXPRESS PRIOR WRITTEN APPROVAL OF THE CHIEF EXECUTIVE OFFICER AND GENERAL COUNSEL OF NATIONAL SEMICONDUCTOR CORPORATION. As used herein:

Life support devices or systems are devices which (a) are intended for surgical implant into the body, or (b) support or sustain life and whose failure to perform when properly used in accordance with instructions for use provided in the labeling can be reasonably expected to result in a significant injury to the user. A critical component is any component in a life support device or system whose failure to perform can be reasonably expected to cause the failure of the life support device or system or to affect its safety or effectiveness.

National Semiconductor and the National Semiconductor logo are registered trademarks of National Semiconductor Corporation. All other brand or product names may be trademarks or registered trademarks of their respective holders.

Copyright© 2007 National Semiconductor Corporation

For the most current product information visit us at www.national.com



National Semiconductor Americas Customer Support Center
 Email: new.feedback@nsc.com
 Tel: 1-800-272-9959

National Semiconductor Europe Customer Support Center
 Fax: +49 (0) 180-530-85-86
 Email: europe.support@nsc.com
 Deutsch Tel: +49 (0) 69 9508 6208
 English Tel: +49 (0) 870 24 0 2171
 Français Tel: +33 (0) 1 41 91 8790

National Semiconductor Asia Pacific Customer Support Center
 Email: ap.support@nsc.com

National Semiconductor Japan Customer Support Center
 Fax: 81-3-5639-7507
 Email: jpn.feedback@nsc.com
 Tel: 81-3-5639-7560