

Stock Code: 300046

TECHSEM



TECH SEMICONDUCTORS CO.,LTD.

No.162 Shengli Street,Xiangyang City,
Hubei Province,China 441021
Tel: +86 710 3506209
Fax: +86 710 3500783
Http://www.tech-sem.com
E-mail: trade@tech-sem.com

TECHSEM

Short Form Catalog 2019-2020



- 1966, Founded factory, produced diode & transistor.
- 1974, Successfully produced the first thyristor in China.
- 1980, Established new plant for special IC and high power transistor.
- 1988, Research and develop power semiconductor module.
- 2010, IPO at Shenzhen Stock Exchange, stock code:300046.
- 2015, IRIS Certified.

Tech Semiconductors Co.,Ltd. (TECHSEM), is a specialized manufacturer in developing, producing and selling power semiconductor devices. It is the first power semiconductor enterprise listed on stock exchange in China.

With more than 50 years experience of semiconductor devices manufacturing, TECHSEM has two clean buildings of over 8000m², in which 1000m² of 100 class cleaning room. Over 480 staffs work in the company, of which 136 are specialized engineers.TECHSEM offers great advantages in technology and production capability.

TECHSEM has a perfect and effective marketing network covering throughout China and the whole world with nearly 200 distributors and 60 sole agents. The production capacity for power semiconductor device amounts up to two million pieces per year.

TECHSEM is pushing on the target of to be the leading competitive supplier for power semiconductors, sincerely hopes to establish trustful and honest business relationship with friends to get mutually benefit and reach a bright future.

All rights reserved.

No part of this publication may be reproduced in any form or by any means photocopying or recording or otherwise, without the prior written permission of the publisher, Tech Semiconductors Co., Ltd.

The contents of this guide may not be considered as an assurance of the test standard of the products.Tech Semiconductors Co., Ltd.reserves the right to make change without further notice to any products here-in. Tech Semiconductors Co., Ltd takes no charge of the possible technical and printed errors and misapprehension for this guide.

Contents

Capsule Type Devices

1

1	Phase Control Thyristors	9	Rectifier Diodes
4	Pulse Power Thyristors	11	Fast Recovery Diodes
5	Fast Turn-off Thyristors	12	Box Clamp
6	Non Symmetric Fast Turn-off Thyristors	13	Reversely Switching Dynistors
7	High Frequency Thyristors	15	Outline
8	Bi-directional Control Thyristors		

Power Modules (Compressive Modules)

24

25	Thyristor Modules	36	Thyristor/Diode Modules(Non-isolated type)
28	Diode Modules	38	Fast Turn-off Thyristor/Fast Recovery Diode Modules
31	Thyristor/Diode Modules	39	Fast Recovery Diode Modules
34	Thyristor Modules(Non-isolatedtype)	40	Normal Module Picture
35	Diode Modules(Non-isolated type)	41	Outline

Power Modules (Soldering Modules)

51

52	Thyristor/Diode Modules	56	Super Fast Recovery Diodes
53	Diode Modules	57	Normal Module Picture
54	Single/three Phases Rectification Bridge Modules	58	Outline
55	Three Phases Rectification Bridge+ thyristor Modules		

IGBT Modules

64

65	Normal Module Picture
66	Insulated Gate Bipolar Transistor

Plastic Fast Recovery Diodes

70

73	Outline
----	---------

Power Semiconductor Assemblies

75

76	Single-phase Full-bridge Assemblies of B2 Series	79	AC Switches Of W Series
77	Three-phase Full-bridge Assemblies of B6 Series	80	High-voltage Assemblies And Assemblies Of HV Series
78	Six-phase Bridge Assemblies of M6 Series	81	Outline

Heatsinks

85

86	Water Cooling	94	Water Cooling Heatsinks of RSS Series
87	Forced Air Cooling	95	Air Cooling Heatsinks of SF Series
91	Water Cooling Heatsinks of SS Series		

Letter Symbols And Terms

98



Capsule Type Devices

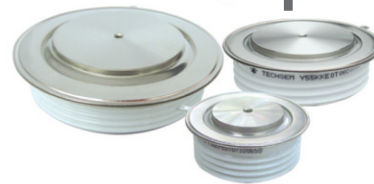



Features

- Amplifying gates
- International standard cases
- Hermetic metal cases with ceramic insulators
- Capsule packages for double sided cooling

Typical Applications

- High power industrial and power transmission
- DC and AC motor control
- Controlled rectifiers
- Soft starters for induction motors
- AC controllers

Type	V _{DRM} /V _{RRM}	I _{T(AV)}	I _{TSM}	I _{GT}	V _{GT}	V _{TM} /I _{TM}	V _{TO}	r _T	R _{th(j-c)}	R _{th(c-hs)}	T _{jm}	Mounting Force	Outline	
		T _c 70°C	10ms	25°C		125°C								
	V	A	kA	mA	V	V/A	V	m.ohm	°C/W	°C/W	°C	kN	Fig.	
Y24KPA	200-600	550	8	30-200	0.8-2.0	1.11/1000	0.75	0.36	0.080	0.020	125	3.3-5.5	T01	
Y30KPA	200-600	860	12	35-250	0.8-2.5	1.23/1500	0.73	0.33	0.045	0.010	125	5.3-10	T02	
Y38KPA	200-600	1300	18	35-300	0.8-2.5	1.10/2000	0.76	0.14	0.035	0.008	125	10-20	T04a	
Y50KPA	200-600	2150	30	40-300	0.8-3.0	1.05/3000	0.75	0.10	0.020	0.005	125	19-26	T07a	
Y24KPC	400-1000	450	6.3	30-200	0.8-2.0	1.29/770	0.75	0.70	0.080	0.020	125	3.3-5.5	T01	
Y30KPC	400-1000	850	9.1	35-250	0.8-2.5	1.24/1550	0.70	0.35	0.045	0.010	125	5.3-10	T02	
Y38KPC	400-1000	1050	15	35-300	0.8-2.5	1.24/1800	0.81	0.24	0.035	0.008	125	10-20	T04c	
Y50KPC	400-1000	1900	29	40-300	0.8-3.0	1.20/2550	0.89	0.12	0.020	0.005	125	19-26	T07c	
Y60KPC	400-1000	2160	33	40-300	0.8-3.0	1.43/4000	0.95	0.12	0.016	0.004	125	21-30	T08c	
Y70KPC	400-1000	3170	38	40-300	0.8-3.0	1.22/5000	0.82	0.08	0.012	0.0035	125	30-40	T09c	
Y76KPC	400-1000	3700	60	40-300	0.8-3.0	1.17/5000	0.86	0.06	0.010	0.003	125	35-47	T11c	
Y89KPC	400-1000	4900	66	40-300	0.8-3.0	1.18/5000	0.88	0.06	0.007	0.002	125	63-84	T12c	
Y100KPC	400-1000	6400	74	40-300	0.8-3.0	1.18/6000	0.85	0.06	0.005	0.0015	125	81-108	T13c	
Y24KPE	1100-1800	420	5	30-200	0.8-2.0	1.22/500	0.82	0.79	0.080	0.020	125	3.3-5.5	T01	
Y30KPE	1100-1800	700	8.3	35-250	0.8-2.5	1.65/1550	0.83	0.53	0.045	0.010	125	5.3-10	T02	
Y38KPE	1100-1800	1000	11	35-300	0.8-2.5	1.28/1700	0.82	0.27	0.035	0.008	125	10-20	T04c	
Y40KPE	1100-1800	1070	12	40-300	0.8-3.0	1.75/2400	0.91	0.35	0.028	0.0075	125	15-20	T05	
Y50KPE	1100-2000	1600	24	40-300	0.8-3.0	1.38/2550	0.87	0.20	0.020	0.0050	125	19-26	T07c	

Type	V _{DRM} /V _{RRM}	I _{T(AV)}	I _{TSM}	I _{GT}	V _{GT}	V _{TM} /I _{TM}	V _{TO}	r _T	R _{th(j-c)}	R _{th(c-hs)}	T _{jm}	Mounting Force	Outline	
		T _c 70°C	10ms	25°C		125°C								
	V	A	kA	mA	V	V/A	V	m.ohm	°C/W	°C/W	°C	kN	Fig.	
Y55KPE	1100-1800	1760	26	40-300	0.8-3.0	1.49/3000	0.95	0.18	0.018	0.004	125	21-30	T08	
Y60KPE	1100-1800	2000	30	40-300	0.8-3.0	1.58/4000	0.98	0.15	0.016	0.004	125	21-30	T08	
Y70KPE	1100-1800	2670	38	40-300	0.8-3.0	1.50/5000	0.80	0.14	0.012	0.003	125	30-40	T09c	
Y76KPE	1100-1800	3440	60	40-300	0.8-3.0	1.29/5000	0.84	0.09	0.010	0.0030	125	35-47	T11c	
Y40KPH	1900-3000	750	10	40-300	0.8-3.0	2.37/1500	1.20	0.78	0.028	0.0075	125	15-20	T05	
Y50KPH	1900-3000	1310	18	40-300	0.8-3.0	1.87/2550	1.03	0.33	0.020	0.0050	125	19-26	T07c	
Y55KPH	1900-3000	1530	23	40-300	0.8-3.0	1.78/3000	0.97	0.27	0.018	0.004	125	21-30	T08	
Y60KPH	1900-3000	1800	23.6	40-300	0.8-3.0	1.61/3000	0.98	0.21	0.016	0.004	125	21-30	T08	
Y70KPH	1900-3000	2070	28	40-300	0.8-3.0	1.83/4000	1.07	0.19	0.012	0.0035	125	30-40	T09c	
Y76KPH	1900-3000	2720	33	40-300	0.8-3.0	1.44/3000	0.95	0.16	0.010	0.0030	125	35-47	T11c	
Y38KPJ	3100-4200	512	7	35-300	0.8-2.5	2.83/1100	1.18	1.50	0.035	0.0080	125	10-20	T04c	
Y50KPJ	3100-4200	1050	15	40-300	0.8-3.0	2.18/1830	1.14	0.57	0.020	0.0050	125	19-26	T07c	
Y70KPJ	3100-4200	1750	18	40-300	0.8-3.0	2.60/3000	1.16	0.34	0.012	0.0035	125	30-40	T09c	
Y76KPJ	3100-4200	2300	25	40-300	0.8-3.0	1.82/3000	1.15	0.22	0.010	0.0030	125	35-47	T11c	
Y100KPJ	3100-4200	4790	60	50-300	0.9-3.5	1.60/6000	0.88	0.12	0.005	0.0015	125	81-108	T13c	
Y38KPM	4300-5200	477	5	35-300	0.8-3.0	2.99/1000	1.21	1.78	0.035	0.0080	125	10-20	T04c	
Y50KPM	4300-5200	930	10	40-300	0.8-3.0	2.58/1830	1.04	0.84	0.020	0.0050	125	19-26	T07c	
Y70KPM	4300-5200	1630	17.5	40-300	0.8-3.0	3.00/3000	1.25	0.39	0.012	0.0035	125	30-40	T09c	
Y76KPM	4300-5200	1942	37	40-300	0.8-3.0	2.21/3000	1.16	0.35	0.010	0.0030	125	35-47	T11c	
Y89KPM	4300-5200	2900	40	40-300	0.8-3.0	1.71/3000	0.99	0.24	0.007	0.0020	125	63-84	T12c	
Y100KPM	4300-5200	3777	45	40-300	0.8-3.0	1.59/3000	0.96	0.21	0.005	0.0015	125	81-108	T13c	

Type	V _{DRM} /V _{RRM}	I _{T(AV)}	I _{TSM}	I _{GT}	V _{GT}	V _{TM} /I _{TM}		V _{TO}	r _T	R _{th(j-c)}	R _{th(c-hs)}	T _{jm}	Mounting Force	Outline
						25°C	125°C							
	V	A	kA	mA	V	V/A	V	m.ohm	°C/W	°C/W	°C	kN	Fig.	
H38KPJ	3600-4500	520	6	40-300	0.8-3.0	2.40/1000	1.10	1.30	0.035	0.0080	125	10-20	T04c	
H50KPJ	3600-4500	1100	15	40-300	0.8-3.0	1.75/1500	1.00	0.50	0.02	0.0050	125	19-26	T07c	
H38KPN	4500-5500	400	4.5	30-300	0.8-3.0	2.80/1000	1.08	1.92	0.045	0.0080	125	10-20	T04d	
H38KPN	4500-5500	440	4.5	30-300	0.8-3.0	2.80/1000	1.08	1.92	0.035	0.0080	125	10-20	T04c	
H50KPN	4500-5500	850	12	30-300	0.8-3.0	1.90/1000	1.07	0.83	0.022	0.0050	125	19-26	T07d	
H50KPN	4500-5500	920	12	30-300	0.8-3.0	1.90/1000	1.07	0.83	0.020	0.0050	125	19-26	T07c	
H76KPN	4500-5500	1800	22	30-300	0.8-3.0	2.20/3000	1.01	0.36	0.011	0.0030	125	35-47	T10d	
H76KPN	4500-5500	1920	22	30-300	0.8-3.0	2.20/3000	1.01	0.36	0.010	0.0030	125	35-47	T10c	
H89KPN	4500-5500	2300	32	30-300	0.8-3.0	1.70/3000	1.03	0.25	0.009	0.0020	125	63-84	T17d	
H100KPN	4500-5500	3500	45	30-300	0.8-3.0	1.54/3000	1.02	0.21	0.0057	0.0015	125	81-108	T14d	
H125KPN	4500-5500	5010	72	30-300	0.8-3.0	1.50/3000	1.02	0.14	0.0040	0.0010	125	110-140	T15d	
H38KPR	5600-6500	350	4.5	40-300	0.8-3.0	3.50/1000	1.25	2.20	0.045	0.0080	125	10-20	T04d	
H38KPR	5600-6500	420	4.5	40-300	0.8-3.0	3.50/1000	1.25	2.20	0.035	0.0080	125	10-20	T04c	
H50KPR	5600-6500	720	11.8	40-300	0.8-3.0	2.40/1000	1.25	1.03	0.022	0.0050	125	19-26	T07d	
H50KPR	5600-6500	830	11.8	40-300	0.8-3.0	2.40/1000	1.25	1.03	0.020	0.0050	125	19-26	T07c	
H76KPR	5600-6500	1370	22	40-300	0.8-3.0	2.12/1500	1.20	0.63	0.011	0.0030	125	35-47	T10d	
H76KPR	5600-6500	1500	22	40-300	0.8-3.0	2.12/1500	1.20	0.63	0.010	0.0030	125	35-47	T10c	
H89KPR	5600-6500	1800	32	40-300	0.8-3.0	1.90/1600	1.22	0.42	0.009	0.0020	125	63-84	T17d	
H100KPR	5600-6500	2800	45	40-300	0.8-3.0	2.00/3000	1.14	0.27	0.0057	0.0015	125	81-108	T14d	
H125KPR	5600-6500	4200	71	40-300	0.8-3.0	1.73/3000	1.15	0.17	0.004	0.0010	125	110-140	T15d	
H38KPS	6600-7200	320	4.0	30-300	0.8-3.0	2.90/500	1.13	3.10	0.045	0.0080	125	10-20	T04d	
H50KPS	6600-7200	650	10.5	30-300	0.8-3.0	2.90/1000	1.28	1.32	0.022	0.0050	125	19-26	T07d	
H38KPU	7300-8500	300	4.0	40-300	0.8-3.0	3.00/500	2.02	2.19	0.045	0.0080	125	10-20	T04d	
H50KPU	7300-8500	600	9.8	40-300	0.8-3.0	2.95/1000	1.04	2.33	0.022	0.0050	125	19-26	T07d	

Features

- Interdigitated amplifying gates
- Fast turn-on and high di/dt
- Low switching losses
- Short turn-off time
- High pulse power current

Typical Applications

- Environment protection facility
- Laser facility
- Electromagnetic drive

Type	I _{PK}	V _{DRM}	V _{RRM}	di/dt ability		dv/dt	T _{jm}	Mounting Force	Outline
	tp:0.3~2.0ms			di/dt	I _{PK}				
	kA	V	V	A/μs	kA	V/μs	°C	kN	Fig.
Voltage to 4500V									
H100KMJ	180	4200	4200	3000	180	2000	110	81~108	T14
H125KMM	250	4500	4500	3000	250	2000	110	110~140	T15
Voltage to 5500V									
H100KMN	150	5500	5500	3000	150	2000	110	81~108	T14
H125KMN	240	5500	5500	3000	240	2000	110	110~140	T15
H150KMN	330	5500	5500	3000	330	2000	110	110~140	T16
Voltage to 6500V									
H76KMR	60	6500	6500	3000	60	2000	110	35~47	T10
H100KMR	120	6500	6500	3000	120	2000	110	81~108	T14
H125KMR	200	6500	6500	3000	200	2000	110	110~140	T15
H150KMR	300	6500	6500	3000	300	2000	110	165~190	T16

Pulse Power Assembly

Pulse power semiconductor devices and assembly, 10-300kA, 10-40kV, have advantages with large surge current, fast turn-on, high di/dt, etc. As per different application at customers, special pulse thyristor, super fast semiconductor devices can be designed in assembly structures which could provide whole electrical functions including trigger, protection etc. Special pulse assembly solution can be provided according to customers application conditions and requirements.

Application: environment protection facility, laser facility, electromagnetic drive, etc.

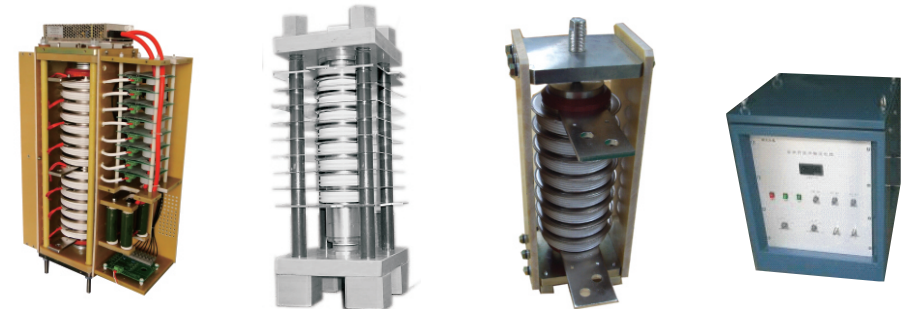

Features

- Interdigitated amplifying gates
- Fast turn-on and high di/dt
- Low switching losses
- Short turn-off time
- Hermetic metal cases with ceramic insulators

Typical Applications

- Inductive heating
- Electronic welders
- Self-commutated inverters
- Ac motor speed control
- General power switching applications



Type	V _{DRM} /V _{RRM}	I _{T(AV)}	t _q	I _{TSM}	dv/dt	di/dt*	V _{TM} /I _{TM}	V _{TO}	r _T	R _{th(j-c)}	R _{th(c-hs)}	T _{jm}	Mounting Force	Outline
		T _c 55°C	125°C	10ms	125°C		125°C							
	V	A	µs	kA	V/µs	A/µs	V/A	V	m.ohm	°C/W	°C/W	°C	kN	
Y30KKE	800-1600	500	18-50	4.3	500	1200	2.82/1000	1.50	1.32	0.045	0.010	125	5.3-10	T02
Y38KKE	800-1800	750	18-50	9.5	500	1200	2.35/1400	1.40	0.68	0.035	0.008	125	10-20	T04c
Y40KKE	800-1800	1080	18-50	10	500	1200	1.98/1800	1.30	0.38	0.028	0.0075	125	15-20	T05
Y45KKE	800-1800	1220	18-50	12	500	1200	2.18/2400	1.32	0.36	0.024	0.006	125	18-25	T06c
Y50KKE	800-1800	1330	18-50	16	500	1200	2.22/2000	1.56	0.33	0.020	0.005	125	19-26	T07c
Y55KKE	800-1800	1460	18-50	17	500	1200	2.47/3000	1.51	0.32	0.018	0.004	125	21-30	T08
Y60KKE	800-1800	1660	18-50	18	500	1200	2.32/3000	1.48	0.28	0.016	0.004	125	21-30	T08
Y65KKE	800-1800	2080	18-50	27	500	1200	2.10/3000	1.41	0.23	0.013	0.0035	125	27-34	T09c
Y70KKE	800-1800	2240	30-60	28	500	1200	2.29/4000	1.45	0.21	0.012	0.003	125	30-40	T09c
Y76KKE	800-1800	2830	30-60	31	500	1200	1.94/4000	1.22	0.18	0.010	0.003	125	35-47	T11c
Y89KKE	800-1800	4240	30-60	45	500	1200	1.71/5000	1.11	0.12	0.007	0.002	125	63-84	T12c
Y65KKG	1900-2500	1840	40-80	21	500	1200	2.62/3600	1.43	0.33	0.013	0.0035	125	27-34	T09c
Y70KKG	1900-2500	2160	40-80	23	500	1200	2.40/4000	1.48	0.23	0.012	0.003	125	30-40	T09c
Y76KKG	1900-2500	2560	40-80	31	500	1200	2.48/5000	1.48	0.20	0.010	0.003	125	35-47	T11c
Y89KKG	1900-2500	3330	40-110	44	500	1200	2.34/5000	1.29	0.21	0.007	0.002	125	63-84	T12c
Y100KKG	1900-3000	4450	40-120	62	500	1200	2.25/5000	1.50	0.15	0.005	0.0015	125	81-108	T13c
Y50KKJ	3100-4100	1250	40-80	13	500	800	3.09/1500	2.70	0.26	0.016	0.005	125	19-26	T07c
Y70KKJ	3100-4000	1770	50-100	18	500	1200	3.4/2000	1.65	0.38	0.012	0.003	125	30-40	T09c
Y76KKJ	3100-4000	1840	50-100	23	500	1200	3.4/2000	1.89	0.42	0.01	0.003	125	35-47	T11c
Y89KKJ	3100-4000	3050	60-150	35	500	1200	2.20/3000	1.48	0.24	0.007	0.002	125	63-84	T12c
Y100KKJ	3100-4000	4100	60-150	44	500	1200	2.20/4000	1.40	0.20	0.005	0.0015	125	81-108	T13c
H76KKM	4100-5200	2240	60-150	21	500	1200	3.2/2000	1.68	0.26	0.01	0.003	125	35-47	T10c
H89KKM	4500-5500	3300	50-150	30	500	1200	3.2/2200	1.58	0.17	0.007	0.002	125	63-84	T17c
H100KKM	4500-5200	4300	60-150	40	500	1200	3.4/2500	1.58	0.15	0.005	0.0015	125	81-108	T14c

*di/dt is the single pulse values

Features

- Fast switching
- Low loss
- Excellent dynamic characteristics

Typical Applications

- Design for inverter supply application

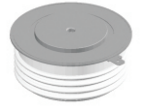

Type	V _{DRM}	V _{RRM}	I _{T(AV)}	t _q	I _{TSM}	dv/dt	di/dt	V _{TM} /I _{TM}	V _{TO}	r _T	R _{th(j-c)}	R _{th(c-hs)}	T _{jm}	Mounting Force	Outline
			@T _c 55°C	125°C	10ms	125°C		25°C	125°C						
	V	V	A	µs	kA	V/µs	A/µs	V/A	V	m.ohm	°C/W	°C/W	°C	kN	
Y50KFE	1200-2000	1000-1800	1200	15 < t _q < 28 29 < t _q < 50	17	1000	1500	2.50/3000 2.10/3000	1.57	0.21	0.02	0.005	125	19-26	T07c
Y60KFE	1200-2000	1000-1800	1600	15 < t _q < 28 29 < t _q < 50	18	1000	1500	2.20/3000 2.00/3000	1.27	0.22	0.016	0.004	125	21-30	T08c
Y70KFE	800-2000	1000-1800	2500	15 < t _q < 28 29 < t _q < 50 51 < t _q < 75	29	1000	1500	2.20/4000 2.00/4000 1.80/4000	1.1	0.13	0.012	0.003	125	30-40	T09
Y76KFE	800-2000	1000-1800	2900	15 < t _q < 35 36 < t _q < 50 51 < t _q < 75	35.6	1000	1500	2.20/4000 2.00/4000 1.80/4000	1.21	0.1	0.01	0.003	125	35-47	T11
Y89KFE	1200-2000	1000-1800	4240	15 < t _q < 35 36 < t _q < 60 61 < t _q < 80	46	1000	1200	2.50/5000 1.80/5000 1.60/5000	1.14	0.11	0.014	0.002	125	63-84	T12
Y50KFG	2000-3000	1000-2500	1000 1200	25 < t _q < 45 36 < t _q < 60 61 < t _q < 75	16	1000 1000	1500 1500	2.80/3000 2.60/3000 2.40/3000	1.55	0.4	0.02	0.005	125	19-26	T07c
Y60KFG	2000-3000	1000-2500	1500	25 < t _q < 45 46 < t _q < 60 61 < t _q < 75	17	1000	1500	2.60/3000 2.40/3000 2.00/3000	1.45	0.23	0.016	0.004	125	21-30	T08c
Y70KFG	2000-3000	1000-2500	2200	25 < t _q < 45 46 < t _q < 60 61 < t _q < 75	28	1000	1500	2.60/4000 2.40/4000 2.20/4000	1.21	0.16	0.012	0.003	125	30-40	T09
Y76KFG	2000-3000	1000-2500	2500 2900	25 < t _q < 45 46 < t _q < 60 61 < t _q < 75	30	1000 1000	1500 1500	2.80/5000 2.60/5000 2.40/5000	1.27	0.15	0.01	0.003	125	35-47	T11
Y89KFG	2000-3000	1000-2500	3500 3800	25 < t _q < 45 46 < t _q < 75 76 < t _q < 100	44	1000 1000	1500 1500	2.60/5000 2.00/5000 1.80/5000	1.32	0.13	0.007	0.002	125	63-84	T12
Y100KFG	2000-3000	1000-2500	4000 4890	25 < t _q < 45 46 < t _q < 75 76 < t _q < 100	63	1000 1000	1200 1200	2.50/5000 1.80/5000 1.60/5000	1.28	0.13	0.005	0.0015	125	81-108	T13
H100KFM	3500-4500	1000-3000	4500	60 < t _q < 100 101 < t _q < 200	50	1000	500	2.60/5000 2.00/5000	1.58	0.15	0.005	0.0015	125	81-108	T14c
H38KFM	4000-4500	1000-3000	350	35 < t _q < 60	5	1000	1200	3.60/1000	1.48	2.0	0.035	0.008	125	10-20	T04c

*di/dt is the single pulse values

Features

- Interdigitated amplifying gates
- Fast turn-on and high di/dt
- Low switching losses
- Short turn-off time
- Hermetic metal cases with ceramic insulators

Typical Applications

- Inductive heating
- Electronic welders
- Self-commutated inverters
- General power switching applications



Features

- International standard cases
- Hermetic metal cases with ceramic insulators
- Capsule packages for double sided cooling

Typical Applications

- High power industrial and power transmission
- DC and AC motor control
- AC controllers



Type	V _{DRM} /V _{RRM}	I _{T(AV)}	I _T /f	t _q	I _{TSM}	dv/dt	di/dt*	V _{TM} /I _{TM}	V _{TO}	r _T	R _{th(j-c)}	R _{th(c-hs)}	T _{jm}	Mounting Force	Outline	
	T _c 55°C		125°C	10ms	125°C			125°C								
	V	A	μs	kA	V/μs	A/μs	V/A	V	m.ohm	°C/W	°C/W	°C	kN	Fig.		
Y38KAB	600-900	750	500/12	5-7	8	200	1500	2.47/1400	1.80	0.48	0.035	0.008	125	10-20	T04c	
Y45KAB	600-900	1210	700/10	6-15	9.6	200	1500	2.23/2400	1.44	0.33	0.024	0.006	125	18-25	T06c	
Y30KAC	800-1200	580	200/10	10-20	5.4	200	1500	2.30/1000	1.45	0.85	0.045	0.010	125	5.3-10	T02	
Y38KAC	800-1200	870	500/10	10-20	9	200	1500	1.97/1200	1.55	0.35	0.035	0.008	125	10-20	T04c	
Y45KAC	800-1200	1110	500/10	10-20	11	200	1500	2.49/2400	1.41	0.45	0.024	0.006	125	18-25	T06c	
Y50KAC	800-1200	1430	600/10	10-20	15	200	1500	1.96/2000	1.32	0.32	0.020	0.005	125	19-26	T07c	
Y55KAC	800-1200	1730	800/8	10-20	17	200	1500	1.96/3000	1.27	0.23	0.018	0.004	125	21-30	T08	
Y30KAD	1100-1400	480	200/6	12-24	5.8	200	1500	2.46/600	1.67	1.32	0.045	0.010	125	5.3-10	T02	
Y38KAD	1100-1400	770	600/6	12-24	9.3	200	1500	2.20/1200	1.50	0.58	0.035	0.008	125	10-20	T04c	
Y45KAD	1100-1400	1050	600/6	15-28	12	200	1500	2.42/1800	1.61	0.45	0.024	0.006	125	18-25	T06c	
Y50KAD	1100-1400	1340	800/6	15-28	18	200	1500	2.34/2400	1.60	0.31	0.020	0.005	125	19-26	T07c	
Y55KAD	1100-1400	1520	1000/6	15-28	18	200	1500	2.38/3000	1.63	0.25	0.018	0.004	125	21-30	T08	

*di/dt is the single pulse values

Type	V _{DRM} /V _{RRM}	I _{T(RMS)}	I _{TSM}	dv/dt	di/dt	I _{DRM} /I _{RRM}	V _{TM} /I _{TM}	V _{TO}	r _T	R _{th(j-c)}	R _{th(c-hs)}	T _{jm}	Mounting Force	Outline	
	T _c 85°C		20ms	125°C		125°C									
	V	A	kA	V/μs	A/μs	mA	V/A	V	m.ohm	°C/W	°C/W	°C	kN	Fig.	
Y30KSE	500-1800	520	5.0	50	50	30	1.78/450	0.85	1.85	0.045	0.010	125	5.3-10	T02a	
Y35KSE	500-1800	750	7.6	50	50	40	1.75/900	0.84	1.01	0.035	0.008	125	10-20	T04c	
Y40KSE	500-1800	930	8.8	50	50	50	1.85/1200	0.78	0.89	0.028	0.0075	125	15-20	T05c	

Features

- Low forward voltage drop
- Reverse voltage up to 6500 v
- Capsule type metal-ceramic packages for double sided cooling

Typical Applications

- All purpose high power rectifier diodes
- High power resistance welding equipment
- Non-controllable and half-controllable rectifiers
- Snubber diodes



Type	V _{RRM}	I _{F(AV)}	I _{FSM}	V _{FM} /I _{FM}	I _{RRM}	V _{FO}	r _F	R _{th(j-c)}	R _{th(c-hs)}	T _{jm}	Mounting Force	Outline
		T _c 85°C	10ms	T _{jm}								
	V	A	kA	V/A	mA	V	m.ohm	°C/W	°C/W	°C	kN	Fig.
Y50ZPA	200-400	7100	55	1.05/5000	50	0.74	0.025	0.010	0.005	175	20-40	Z15
Y24ZPB	200-1000	860	8	1.46/1930	16	0.8	0.34	0.080	0.020	190	3.3-5.5	Z01
Y30ZPB	200-1000	1380	11	1.16/1200	30	0.87	0.24	0.045	0.010	190	5.3-10	Z02
Y38ZPB	200-1000	1700	18	1.82/4400	40	0.81	0.23	0.035	0.008	190	10-20	Z03c
Y40ZPB	200-1000	2160	19	1.36/3000	50	0.86	0.165	0.028	0.0075	190	15-20	Z04
Y50ZPB	200-1000	3180	30	1.01/2000	80	0.79	0.11	0.020	0.005	190	19-26	Z06c
Y65ZPB	200-1000	5630	58	0.92/5000	100	0.63	0.058	0.013	0.0035	190	27-34	Z08
Y76ZPB	200-1000	7460	69	0.89/5000	100	0.69	0.039	0.010	0.003	190	35-47	Z09c
Y24ZPC	1100-2000	560	4.9	2.10/1500	16	0.8	0.86	0.080	0.020	175	3.3-5.5	Z01
Y30ZPC	1100-2000	1080	9	2.22/3770	30	0.98	0.33	0.045	0.010	175	5.3-10	Z02
Y38ZPC	1100-2000	1480	14	1.94/3770	40	0.85	0.29	0.032	0.008	175	10-20	Z03c
Y40ZPC	1100-2000	1790	18	1.52/3000	50	0.90	0.204	0.028	0.0075	175	15-20	Z04
Y50ZPC	1100-2000	2490	25.7	1.57/4500	80	0.89	0.15	0.020	0.005	175	19-26	Z06c
Y60ZPC	1100-2000	3520	34	1.13/4000	120	0.73	0.10	0.016	0.004	175	21-30	Z07
Y70ZPC	1100-2000	4520	44	1.22/5000	160	0.85	0.073	0.012	0.003	175	30-40	Z08c
Y76ZPC	1100-2000	5220	56.4	1.31/6800	200	0.84	0.069	0.010	0.003	175	35-47	Z09c
Y89ZPC	1100-2000	7090	83	1.01/5000	200	0.68	0.065	0.007	0.002	175	63-84	Z10c
Y100ZPC	1100-2000	8000	94	1.28/6000	250	0.85	0.071	0.005	0.0015	175	81-108	Z11
Y38ZPD	2100-3000	1150	12	1.41/1500	40	0.88	0.35	0.035	0.010	160	10-20	Z03c
Y50ZPD	2100-3000	2210	23	1.55/4500	80	0.83	0.16	0.020	0.005	160	19-26	Z06c
Y60ZPD	2100-3000	2720	28	2.00/3000	120	0.92	0.12	0.016	0.004	160	21-30	Z07
Y70ZPD	2100-3000	3470	35	1.45/5000	160	0.95	0.10	0.012	0.003	160	30-40	Z08c
Y76ZPD	2100-3000	4000	45	1.80/5000	200	0.90	0.099	0.010	0.003	160	35-47	Z09c
Y89ZPD	2100-3000	5210	62	1.29/5000	200	0.80	0.098	0.007	0.002	160	63-84	Z10c

Type	V _{RRM}	I _{F(AV)}	I _{FSM}	V _{FM} /I _{FM}	I _{RRM}	V _{FO}	r _F	R _{th(j-c)}	R _{th(c-hs)}	T _{jm}	Mounting Force	Outline
		T _c 85°C	10ms	T _{jm}								
	V	A	kA	V/A	mA	V	m.ohm	°C/W	°C/W	°C	kN	Fig.
Y50ZPE	3100-4200	1770	18	1.97/3800	80	0.98	0.26	0.020	0.005	160	19-26	Z06c
Y70ZPE	3100-4200	3090	35	1.48/4000	160	0.88	0.15	0.012	0.003	160	30-40	Z08c
Y76ZPE	3100-4200	3500	41	1.78/6000	200	0.95	0.138	0.010	0.003	160	35-47	Z09c
Y100ZPE	3100-4200	6490	80	1.44/6000	250	0.92	0.087	0.005	0.0015	160	81-108	Z11
Y38ZPG	4300-5000	920	6	1.44/1000	50	0.99	0.45	0.035	0.008	150	10-20	Z03c
Y50ZPG	4300-5000	1640	14	1.36/1500	100	0.98	0.25	0.020	0.005	150	19-26	Z06c
Y65ZPG	4300-5000	2890	26	1.23/3000	150	0.86	0.122	0.013	0.0035	150	27-34	Z08
Y76ZPG	4300-5000	3290	35	2.00/4000	200	0.88	0.12	0.01	0.003	150	35-47	Z09c
Y89ZPG	4300-5000	4560	45	2.00/4500	250	0.91	0.10	0.007	0.002	150	63-84	Z10c
Y100ZPG	4300-5000	5650	58	1.41/5000	300	0.91	0.10	0.005	0.0015	150	81-108	Z11
T38ZPR	5600-6500	500*	9.5	2.20/1000	50	0.89	1.05	0.045	0.008	150	10-20	Z03d
T50ZPR	5600-6500	970*	16.5	2.15/1500	100	0.91	0.60	0.022	0.005	150	19-26	Z06d
T65ZPR	5600-6500	1510*	26	1.85/3000	200	0.92	0.39	0.014	0.0035	150	27-34	Z08d
T76ZPR	5600-6500	2000*	35	1.80/3000	300	0.94	0.27	0.011	0.003	150	35-47	Z09d
H100ZPR	5100-6500	4380*	57	1.70/5000	300	0.88	0.16	0.0057	0.0015	150	81-108	Z12
H125ZPR	5100-6500	5250*	84	1.65/5000	400	0.81	0.12	0.004	0.001	150	110-140	Z13d
H150ZPR	5100-6500	6700*	120	1.50/5000	500	0.72	0.115	0.0028	0.0006	150	165-190	Z16

note: "*" is the current at T_c=100°C

Features

- Small recovered charge
- Soft recovery
- Up to 5000 v reverse voltage
- Capsule type metal-ceramic packages for double sided cooling

Typical Applications

- Inverse diodes for power transistors, GTO thyristors
- AC motor control
- Snubber diodes and free-wheeling diodes
- UPS



Type	V_{RRM}	$I_{F(AV)}$	I_{FSM}	I_{RRM}	t_{rr}	Q_{rr}	125°C			$R_{th(j-c)}$	$R_{th(c-hs)}$	T_{jm}	Mounting Force	Outline
	V	$T_c 70^{\circ}\text{C}$	10ms	125°C			125°C			$^{\circ}\text{C}/\text{W}$	$^{\circ}\text{C}/\text{W}$	$^{\circ}\text{C}$	kN	Fig.
		A	kA	mA	μs	μC	V/A	V	m.ohm					
Y24ZKC	1100-2000	340	5.4	16	2	< 70	1.87/600	1.48	0.65	0.080	0.020	125	3.3-5.5	Z01
Y30ZKC	1100-2000	630	7.5	30	3	< 90	1.80/1200	1.30	0.42	0.045	0.010	125	5.3-10	Z02
Y38ZKC	1100-2000	780	10	40	3	< 130	2.20/2400	1.31	0.37	0.035	0.008	125	10-20	Z03c
Y50ZKC	1100-2000	1330	19	80	6	< 250	2.00/3000	1.37	0.21	0.020	0.005	125	19-26	Z06c
Y60ZKC	1100-2000	1830	25	100	7	< 550	1.96/5000	1.16	0.16	0.016	0.004	125	21-30	Z07
Y70ZKC	1100-2000	2340	31	150	7	< 1000	1.85/5000	1.10	0.15	0.012	0.003	125	30-40	Z08c
Y76ZKC	1100-2000	3180	44	200	7	< 1300	1.45/5000	0.95	0.10	0.010	0.003	125	35-47	Z09c
Y38ZKD	2100-3000	630	8.5	40	4	< 150	2.23/1000	1.78	0.45	0.035	0.008	125	10-20	Z03c
Y50ZKD	2100-3000	1110	16	80	7	< 650	1.99/1500	1.40	0.39	0.020	0.005	125	19-26	Z06c
Y60ZKD	2100-3000	1340	20	100	8	< 1010	2.18/2000	1.58	0.30	0.016	0.004	125	21-30	Z07
Y70ZKD	2100-3000	1670	25	180	10	< 1500	2.42/3000	1.55	0.29	0.012	0.003	125	30-40	Z08c
Y76ZKD	1800-3000	2300	26	200	10	< 1500	1.90/3000	1.20	0.21	0.010	0.003	125	35-47	Z09c
Y24ZKG	4000-5000	210	2.7	20	4	< 100	3.18/500	1.36	3.63	0.080	0.020	125	3.3-5.5	Z01
Y38ZKG	4000-5000	480	6.5	50	6	< 960	3.07/1000	1.89	1.18	0.035	0.008	125	10-20	Z03c
Y50ZKG	4000-5000	940	14	100	9	< 1800	2.50/1500	1.73	0.51	0.020	0.005	125	19-26	Z06c
Y70ZKG	4000-5000	1600	26	200	12	< 1900	2.90/3000	1.68	0.30	0.012	0.003	125	30-40	Z08c
Y76ZKG	4000-5000	1940	27	250	12	< 2200	2.40/3000	1.65	0.25	0.010	0.003	125	35-47	Z09c
Y89ZKG	4000-5000	2600	40	120	15	< 8000	2.60/5000	1.10	0.47	0.005	0.0015	125	63-84	Z10c

The modules can comprise one or two capsule type devices on a common isolated base-plate, user only requires four fixing screws for mounting to a suitable heatsink.

Type	Number of devices	I_{TAV} @ $T_c 70^{\circ}\text{C}$ A	V_{DRM}/V_{RRM} V	$R_{th(j-c)}$ $^{\circ}\text{C}/\text{W}$	T_{jm} $^{\circ}\text{C}$
MP25A-200	1	200	400-1800	0.20	125
MP25B-200	2				
MP25A-250	1	250	400-1800	0.13	125
MP25B-250	2				
MP33A-400	1	400	400-1800	0.09	125
MP33B-400	2				

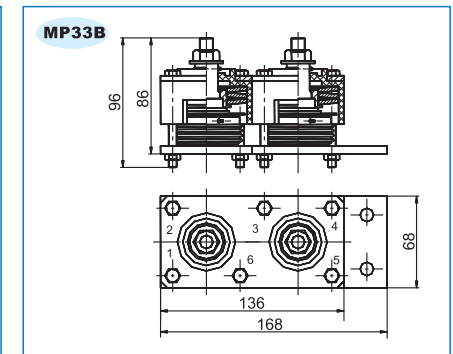
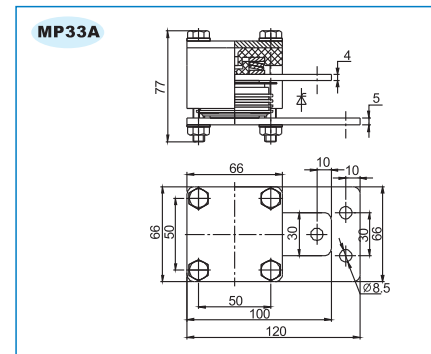
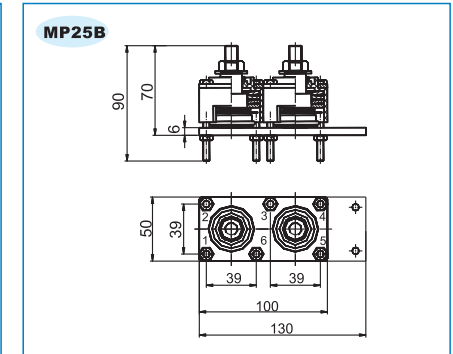
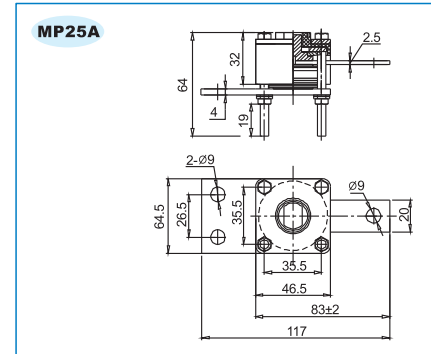

Features

- high power
- easy series or parallel connections
- high reliability
- no warm-up
- long life
- low price

Typical Applications

- Generator for power exciter laser pumping
- Waste water treatment by power electric discharge
- Pulse energization of electrostatic precipitator
- Power magnetron modulation

Type	Repetitive peak off-state voltage	Repetitive peak sine current pulse	Surge on-state current	Peak forward voltage	Critical rate of rise of on-state current	Critical rate of rise of off-state voltage	Trigger current	Trigger current duration	Turn-off time	Mounting force	Outline
	V_{DRM} kV	I_p (50 μ s) kA	I_{TSM} (10ms) kA	$V_{TM}(@I_p)$ V	di/dt kA/ μ s	dv/dt kV/ μ s	I_{RT} kA	T_T μ s	t_q μ s	F kN	
Y20DSC	1.0	10	1	15	3.0	0.6	0.05	1.0-2.0	15	3.3-5.5	Z01
Y20DSE	1.8	10	1	20	2.5	0.6	0.05	1.5-2.5	100	3.3-5.5	Z01
Y38DSC	1.2	50	5	20	15	0.8	0.25	1.0-2.0	25	10-20	Z03a
Y38DSE	1.8	50	5	20	15	0.8	0.25	1.5-2.5	60	10-20	Z03a
Y38DSF	2.5	50	5	20	13	0.8	0.25	1.5-2.5	80	10-20	Z03a
Y50DSE	2.0	100	10	20	25	0.8	0.5	1.5-2.5	120	19-26	Z06a
Y50DSF	2.5	100	10	20	25	0.8	0.5	1.5-2.5	150	19-26	Z06a
Y65DSE	2.0	180	18	20	40	0.8	1.1	1.5-3.0	120	27-34	Z08c
Y65DSH	3.0	180	18	20	40	1.0	1.1	1.5-3.0	230	27-34	Z08c
Y76DSE	2.0	250	25	20	60	0.8	1.5	1.5-3.0	150	35-47	Z09c
Y76DSH	3.0	250	25	25	60	1.0	1.5	1.5-3.0	250	35-47	Z09c
Y38DSR	6.5	50	5	20	13	0.8	1.0	1.5-2.0	120	10-20	Z03a

Structure and principle

Fig 1 is the RSD-Based Pulse Power Generator, consists of Main Circuit and Trigger Circuit. The Main Circuit consists of a main capacitance C, a saturable core choke L and load R_L . The Trigger Circuit consists of a switch K, capacitance C_T and R_T .

RSD is power thyristor-type device especially designed for Pulsed Power Technology. The main advantages of RSD are very low switching losses due to uniform switching over the semiconductor structure area, very high di/dt capability, zero delay time between triggering and main current pulses. These peculiarities lead to very high switching capability of RSD and to high reliability of power systems consisting of many RSD connected in parallel and in series.

Fig.1 RSD-Based Pulse Power Generator

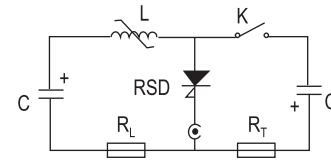

Fig.2 Equivalent structure of RSD

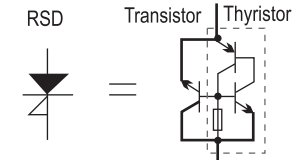

Fig 2 is the equivalent structure of RSD. When the switch K in Fig 1 is closed, the RSD is triggered by short (1~3 μ s) reverse current from the Trigger circuit. During this reverse, the short reverse current pulse passes through the semiconductor structure forming the thin electron-hole plasma layer in the collector junction plane. Then the applied voltage polarity returns to the initial state where the plasma layer uniformly distributes the gate electron, which injects majority carriers into the base layers of the RSD's structure. When properly triggered, the RSD can switch very high current. Fig.3 is a typical voltage and current waves on RSD switching.

Fig.3 Voltage and current waves on RSD switching

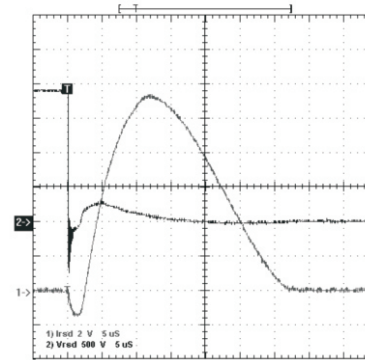
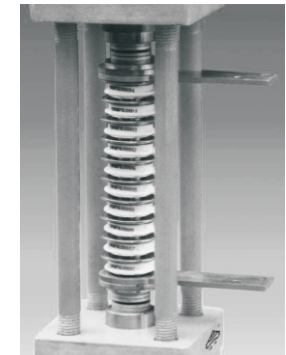

Fig.4 30KV RSD STACK



T01

Code	Case Style	D	Weight	Mounting Force
T01a	KT19aT	13.8±0.6	0.06Kg	3.3-5.5kN

T02

Code	Case Style	D	Weight	Mounting Force
T02a	KT25aT	14.6±0.5	0.08Kg	5.3-10kN

T05

Code	Case Style	D	Weight	Mounting Force
T05c	KT39cT	26.0±0.5	0.32Kg	15-20kN

T06

Code	Case Style	D	Weight	Mounting Force
T06a	KT44aT	15.0±0.5	0.17Kg	18-25kN
T06c	KT44cT	26.0±0.5	0.38Kg	18-25kN

T03

Code	Case Style	D	Weight	Mounting Force
T03a	KT30aT	14.5±0.5	0.14Kg	6-12kN
T03c	KT30cT	26.0±0.5	0.22Kg	6-12kN

T04

Code	Case Style	D	Weight	Mounting Force
T04a	KT33aT	15.0±0.5	0.15Kg	10-20kN
T04c	KT33cT	26.0±0.5	0.24Kg	10-20kN
T04d	KT33dT	35.0±0.5	0.30Kg	10-20kN

T07

Code	Case Style	D	Weight	Mounting Force
T07a	KT50aT	14.8±0.5	0.29Kg	19-26kN
T07c	KT50cT	26.0±0.5	0.44Kg	19-26kN
T07d	KT50dT	35.0±0.5	0.56Kg	19-26kN

T08

Code	Case Style	D	Weight	Mounting Force
T08a	KT54aT	14.7±0.5	0.35Kg	27-34kN
T08c	KT54cT	26.0±0.5	0.59/0.64Kg	27-34kN

T09

Code	Case Style	D	Weight	Mounting Force
T09c	KT60cT	26.0±0.5	0.82/0.88Kg	27~34kN
T09d	KT60dT	35.0±0.5	1.10Kg	27~34kN

T10

Code	Case Style	D	Weight	Mounting Force
T10c	KT60cTY	26.0±0.5	0.88Kg	35~47kN
T10d	KT60dT	35.0±0.5	1.14Kg	35~47kN

T13

Code	Case Style	D	Weight	Mounting Force
T13c	KT100cT	26.5±0.5	2.0Kg	81~108kN
T13d	KT100dT	35.0±0.5	2.5Kg	81~108kN

T14

Code	Case Style	D	Weight	Mounting Force
T14c	KT100cTY	26.5±0.5	1.88Kg	81~108kN
T14d	KT100dT	35.0±0.5	2.5Kg	81~108kN

T11

Code	Case Style	D	Weight	Mounting Force
T11c	KT73cT	26.0±0.5	1.10Kg	35~47kN
T11d	KT73dT	35.0±0.5	1.46Kg	35~47kN

T12

Code	Case Style	D	Weight	Mounting Force
T12c	KT84cT	26.0±0.5	1.39Kg	63~84kN
T12d	KT84dT	35.0±0.5	1.92Kg	63~84kN

T15

Code	Case Style	D	Weight	Mounting Force
T15c	KT110cT	26.0±0.5	2.62Kg	110~140kN
T15d	KT110dT	35.0±0.5	3.42Kg	110~140kN

T16

Code	Case Style	D	Weight	Mounting Force
T16c	KT140cT	26.0±0.5	3.42Kg	110~140kN
T16d	KT140dT	35.0±0.5	4.0Kg	165~190kN

T17

Code	Case Style	D	Weight	Mounting Force
T17c	KT78cT	26.5±0.5	2.62Kg	110~140kN
T17d	KT78dT	35.0±0.5	3.42Kg	110~140kN

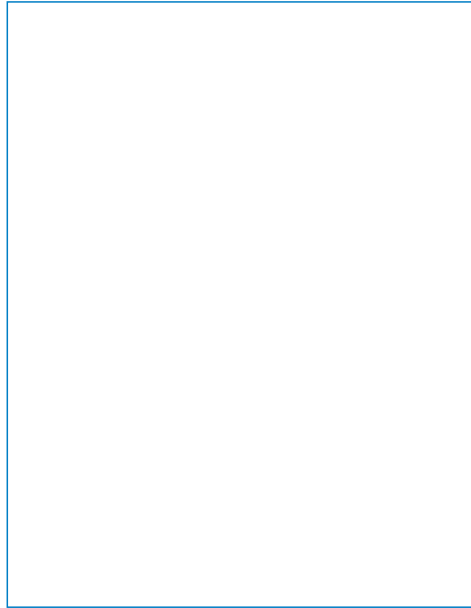

Z01

Code	Case Style	D	Weight	Mounting Force
Z01a	ZT19aT	13.8±0.6	0.06Kg	3.3~5.5kN

Z02

Code	Case Style	D	Weight	Mounting Force
Z02a	ZT25aT	14.6±0.5	0.08Kg	5.3~10kN

Z03

dT: $\varnothing 3.5 \times 3$
cT: $\varnothing 3.5 \times 3$
aT: $\varnothing 3.5 \times 1.5$

Code	Case Style	D	Weight	Mounting Force
Z03a	ZT33aT	15.0±0.5	0.15Kg	10~20kN
Z03c	ZT33cT	26.0±0.5	0.24Kg	10~20kN
Z03d	ZT33dT	35.0±0.5	0.34Kg	10~20kN

Z04

Code	Case Style	D	Weight	Mounting Force
Z04c	ZT39cT	26.0±0.5	0.32Kg	15~20kN

Z05

$\varnothing 3.5 \times 3$
 $\varnothing 69$
 $\varnothing 45$
 $\varnothing 45$
 $\varnothing 62$
 D

Code	Case Style	D	Weight	Mounting Force
Z05c	ZT44cT	26.0±0.5	0.38Kg	18~25kN

Z06

$dT: \varnothing 3.5 \times 3$
 $cT: \varnothing 3.5 \times 3$
 $aT: \varnothing 3.5 \times 1.5$
 $\varnothing 74$
 $\varnothing 47$
 $\varnothing 47$
 $\varnothing 66$
 D

Code	Case Style	D	Weight	Mounting Force
Z06a	ZT50aT	15.0±0.5	0.29Kg	19~26kN
Z06c	ZT50cT	26.0±0.5	0.44Kg	19~26kN
Z06d	ZT50dT	35.0±0.5	0.59Kg	19~26kN

Z09

$\varnothing 3.5 \times 3$
 $\varnothing 110$
 $\varnothing 73$
 $\varnothing 73$
 D

Code	Case Style	D	Weight	Mounting Force
Z09c	ZT73cT	26.0±0.5	1.10Kg	35~47kN
Z09d	ZT73dT	35.0±0.5	1.46Kg	35~47kN

Z10

$\varnothing 3.5 \times 3$
 $\varnothing 119$
 $\varnothing 84$
 $\varnothing 84$
 $\varnothing 110$
 D

Code	Case Style	D	Weight	Mounting Force
Z10c	ZT84cT	26.0±0.5	1.39Kg	63~84kN
Z10d	ZT84dT	35.0±0.5	1.92Kg	63~84kN

Z07

$\varnothing 3.5 \times 3$
 $\varnothing 84$
 $\varnothing 55$
 $\varnothing 55$
 $\varnothing 75$
 D

Code	Case Style	D	Weight	Mounting Force
Z07c	ZT54cT	26.0±0.5	0.64Kg	21~30kN

Z08

$\varnothing 3.5 \times 3$
 $\varnothing 100$
 $\varnothing 63$
 $\varnothing 63$
 $\varnothing 88$
 D

Code	Case Style	D	Weight	Mounting Force
Z08c	ZT60cT	26.0±0.5	0.82Kg	27~34kN
Z08d	ZT60dT	35.0±0.5	1.10Kg	27~34kN

Z11

$\varnothing 3.5 \times 3$
 $\varnothing 143$
 $\varnothing 100$
 $\varnothing 100$
 $\varnothing 132$
 D

Code	Case Style	D	Weight	Mounting Force
Z11c	ZT100cT	26.5±0.5	2.0Kg	81~108kN

Z12

$\varnothing 3.5 \times 3$
 $\varnothing 149$
 $\varnothing 100$
 $\varnothing 100$
 $\varnothing 138$
 D

Code	Case Style	D	Weight	Mounting Force
Z12c	ZT100cTY	26.5±0.5	2.02Kg	81~108kN

Z13

Code	Case Style	D	Weight	Mounting Force
Z13d	ZT110dT	35.0±0.5	3.42Kg	110~140kN

Z14

Code	Case Style	D	Weight	Mounting Force
Z14a	ZT50T	8.7±0.5	0.16Kg	19~26kN

Z15

Code	Case Style	D	Weight	Mounting Force
Z15a	ZT44T	8.0±0.5	0.14Kg	19~26kN

Z16

Code	Case Style	D	Weight	Mounting Force
Z16d	ZT140dT	35.0±0.5	4.0Kg	165~190kN



Power Modules (compressive Modules)

Features

- Isolated mounting base, 3000&4000V~
- International standard package
- Pressure contact technology with increased power cycling capability
- Simple mounting and easy maintenance
- Space and weight saving

Notes

- All data apply to single thyristor
- All thermal resistance apply to single thyristor

Typical Applications

- AC/DC Motor drives
- Various rectifiers
- Heater controls
- Lighting controls
- Contactless switches
- Soft start AC motor control (TSC)SVC
- Welding power supply
- DC supply for PWM inverter
- Battery DC chargers or dischargers
- UPS



Type	V _{DRM} /V _{RRM}		I _{T(AV)}	I _{TSM}	dv/dt	di/dt	I _{DRM} /I _{RRM}	I _{GT}	V _{GT}	I _H	V _{TM} /I _{TM}	V _{TO}	r _T	R _{th(j-c)}	T _{jm}	V _{iso}	Outline
	125°C	T _c 85°C			125°C		125°C	25°C, Max			125°C		per chip				
	V	A	kA	V/μs	A/μs	mA	mA	V	mA	V/A	V	m.ohm	°C/W	°C	V(AC)	Fig.	
MTx26	600-1800	26	0.5	1000	200	8	150	2.5	120	1.69/80	0.85	9.68	0.95	125	3000	M01	
MTx40	600-1800	40	0.9	1000	200	8	150	2.5	120	1.60/120	0.85	5.57	0.65	125	3000	M01	
MTx55	600-1800	55	1.3	1000	200	8	150	2.5	120	1.55/170	0.85	3.47	0.53	125	3000	M01	
MTx70	600-1800	70	1.5	1000	200	10	150	2.5	120	1.50/210	0.80	2.64	0.41	125	3000	M01	
MTx90	600-1800	90	1.8	1000	200	12	150	2.5	120	1.73/270	0.80	3.01	0.28	125	3000	M01	
MTx110	600-1800	110	2.2	1000	200	12	150	2.5	120	1.69/330	0.80	2.29	0.25	125	3000	M01	
MTx135	600-1800	135	3.6	1000	200	20	150	2.5	120	1.75/410	0.80	2.60	0.18	125	3000	M02	
MTx160	600-1800	160	5.2	1000	200	20	150	2.5	120	1.61/480	0.80	1.69	0.17	125	3000	M02	
MTx182	600-1800	182	5.4	1000	200	20	150	2.5	120	1.62/550	0.80	1.26	0.16	125	3000	M02	
MTx250	600-1800	250	9	1000	200	25	180	2.5	150	1.57/750	0.80	0.85	0.12	125	3000	M03	
MTx285	600-1800	285	9.1	1000	200	25	180	2.5	150	1.45/860	0.80	0.42	0.12	125	3000	M03	
MTx300	600-1800	300	9.1	1000	200	25	180	2.5	150	1.56/900	0.80	0.42	0.12	125	3000	M03	
MTx330	600-1800	330	9.1	1000	200	25	180	2.5	150	1.45/990	0.80	0.53	0.12	125	3000	M03	
MTx350	600-1800	350	11	1000	200	35	180	2.5	150	1.45/1050	0.95	0.36	0.09	125	3000	M05	
MT400	600-1800	400	12.5	1000	200	35	200	3.0	200	1.52/1200	0.80	0.49	0.08	125	3000	M06	
MT500	600-1800	500	14.5	1000	200	35	200	3.0	200	1.44/1500	0.80	0.34	0.065	125	3000	M06	
MTx400	600-1800	400	14.5	1000	200	35	200	3.0	200	1.52/1200	0.80	0.34	0.065	125	3000	M07	
MTx500	600-1800	500	14.5	1000	200	35	200	3.0	200	1.44/1500	0.80	0.34	0.065	125	3000	M07	
MTx570	600-1800	570	15	1000	200	35	200	3.0	200	1.45/1800	0.80	0.20	0.065	125	3000	M07	

Type	V _{DRM} /V _{RRM}		I _{T(AV)}	I _{TSM}	dv/dt	di/dt	I _{DRM} /I _{RRM}	I _{GT}	V _{GT}	I _H	V _{TM} /I _{TM}	V _{TO}	r _T	R _{th(j-c)}	T _{jm}	V _{iso}	Outline
	125°C	T _c 85°C			125°C		125°C	25°C, Max			125°C		per chip				
	V	A	kA	V/μs	A/μs	mA	mA	V	mA	V/A	V	m.ohm	°C/W	°C	V(AC)	Fig.	
MTx600	600-1800	600	16	1000	200	45	200	3.0	200	1.45/1800	0.80	0.28	0.054	125	3000	M08	
MT600	600-1800	600	16	1000	200	45	200	3.0	200	1.45/1800	0.80	0.28	0.054	125	3000	M09	
MTx800	600-1800	800	22	1000	200	45	200	3.0	200	1.86/2400	0.80	0.20	0.042	125	3000	M08	
MT800	600-1800	800	22	1000	200	55	150	3.0	150	1.60/2400	0.80	0.20	0.042	125	3000	M09	
MTx1000	600-1800	1000	28	1000	200	55	200	3.0	200	1.65/3000	0.80	0.15	0.034	125	3000	M10	
MTx1200	600-1800	1200	34	1000	200	55	200	3.0	200	1.76/3000	0.80	0.09	0.031	125	3000	M10	

Type	V _{DRM} /V _{RRM}		I _{T(AV)}	I _{TSM}	dv/dt	di/dt	I _{DRM} /I _{RRM}	I _{GT}	V _{GT}	I _H	V _{TM} /I _{TM}	V _{TO}	r _T	R _{th(j-c)}	T _{jm}	V _{iso}	Outline
	125°C	T _c 85°C			125°C		125°C	25°C, Max			125°C		per chip				
	V	A	kA	V/μs	A/μs	mA	mA	V	mA	V/A	V	m.ohm	°C/W	°C	V(AC)	Fig.	
MTx26	1900-2500	26	0.48	1000	200	10	150	2.5	150	1.80/80	0.85	9.68	0.95	125	3000	M01	
MTx40	1900-2500	40	0.86	1000	200	10	150	2.5	150	1.86/120	0.85	5.57	0.65	125	3000	M01	
MTx55	1900-2500	55	1.24	1000	200	10	150	2.5	150	1.98/160	0.85	4.80	0.49	125	3000	M01	
MTx70	1900-2500	70	1.43	1000	200	12	150	2.5	150	1.93/210	0.85	3.50	0.39	125	3000	M01	
MTx90	1900-2500	90	1.50	1000	200	15	150	2.5	150	1.93/270	0.85	3.26	0.28	125	3000	M01	
MTx110	1900-2500	110	1.60	1000	200	15	150	2.5	150	1.95/330	0.85	2.25	0.25	125	3000	M01	
MTx135	1900-2500	135	3.6	1000	200	30	150	2.5	150	1.96/410	0.85	1.91	0.20	125	3000	M02	
MTx160	1900-2500	160	4.2	1000	200	30	150	2.5	150	1.90/480	0.85	1.53	0.17	125	3000	M02	
MTx182	1900-2500	182	4.5	1000	200	30	150	2.5	150	1.84/550	0.85	1.21	0.16	125	3000	M02	
MTx200	1900-2500	200	8	1000	200	35	180	2.5	150	1.90/600	0.85	1.14	0.14	125	3000	M03	
MTx250	1900-2500	250	9	1000	200	35	180	2.5	150	1.70/750	0.85	0.80	0.12	125	3000	M03	
MTx300	1900-2500	300	9.2	1000	200	45	180	2.5	150	1.99/900	0.85	0.65	0.10	125	3000	M03	
MTx350	1900-2500	350	11	1000	200	45	180	2.5	150	1.89/1050	0.84	0.50	0.09	125	3000	M05	
MT400	1900-2500	400	12.5	1000	200	45	200	3.0	200	1.74/1200	0.83	0.42	0.08	125	3000	M06	
MT500	1900-2500	500	14.5	1000	200	45	200	3.0	200	1.74/1200	0.85	0.39	0.06	125	3000	M06	
MTx400	1900-2500	400	12.5	1000	200	45	200	3.0	200	1.92/1500	0.83	0.42	0.08	125	3000	M07	
MTx500	1900-2500	500	14.5	1000	200	45	200	3.0	200	2.20/1500	0.85	0.39	0.06	125	3000	M07	
MT600	1900-2500	600	16	1000	200	50	200	3.0	200	1.80/1800	0.88	0.24	0.054	125	3000	M09	
MTx600	1900-2500	600	16	1000	200	50	200	3.0	200	1.65/1800	0.88	0.24	0.054	125	3000	M08	

Type	V_{DRM}/V_{RRM}	$I_{T(AV)}$	I_{TSM}	dv/dt	di/dt	I_{DRM}/I_{RRM}	I_{GT}	V_{GT}	I_H	V_{TM}/I_{TM}	V_{TO}	r_T	$R_{th(j-c)}$	T_{jm}	V_{iso}	Outline
	125°C	T_c 85°C	10ms	125°C	125°C	25°C, Max			125°C		per chip	°C/W	°C	V(AC)	Fig.	
	V	A	kA	V/μs	A/μs	mA	mA	V	mA	V/A	V	m.ohm	°C/W	°C	V(AC)	Fig.
MTx800	1900-2500	800	22	1000	200	50	200	3.0	200	2.00/2400	0.85	0.17	0.042	125	3000	M08
MT800	1900-2500	800	22	1000	200	50	200	3.0	200	2.00/2400	0.85	0.17	0.042	125	3000	M09
MTx1000	1900-2500	1000	28	1000	200	60	200	3.0	200	2.10/3000	0.85	0.14	0.034	125	3000	M10
MTx1200	1900-2500	1200	34	1000	200	60	200	3.0	200	2.00/3000	0.85	0.077	0.031	125	3000	M10

Type	V_{DRM}/V_{RRM}	$I_{T(AV)}$	I_{TSM}	dv/dt	di/dt	I_{DRM}/I_{RRM}	I_{GT}	V_{GT}	I_H	V_{TM}/I_{TM}	V_{TO}	r_T	$R_{th(j-c)}$	T_{jm}	V_{iso}	Outline
	125°C	T_c 85°C	10ms	125°C	125°C	25°C, Max			125°C		per chip	°C/W	°C	V(AC)	Fig.	
	V	A	kA	V/μs	A/μs	mA	mA	V	mA	V/A	V	m.ohm	°C/W	°C	V(AC)	Fig.
MTx200	2600-3600	200	8	1000	200	40	180	2.5	150	2.55/600	0.96	1.30	0.12	125	4000	M04
MTx250	2600-3600	250	9	1000	200	55	180	2.5	150	2.63/750	0.91	0.90	0.11	125	4000	M05
MTx300	2600-3600	300	9.2	1000	200	55	180	2.5	150	2.45/900	0.93	1.00	0.08	125	4000	M05
MTx400	2600-3600	400	12.5	1000	200	55	200	3.0	200	2.35/1200	0.98	0.88	0.054	125	4000	M08
MTx500	2600-3600	500	14.5	1000	200	55	200	3.0	200	2.70/1500	0.95	0.51	0.050	125	4000	M08
MT600	2600-3600	600	16	1000	200	80	200	3.0	200	2.55/1800	0.80	0.29	0.054	125	4000	M09

* MTx shows any type of MT、MTC、MTA、MTK

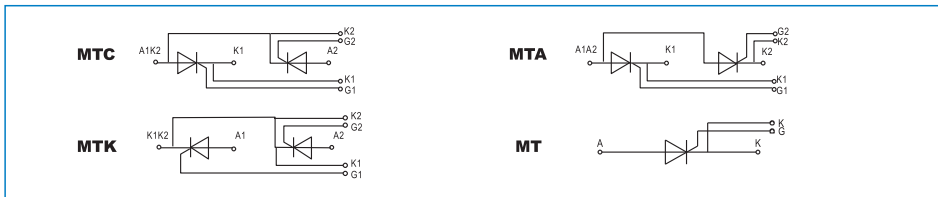

Features

- Isolated mounting base, 3000&4000V~
- International standard package
- Pressure contact technology with increased power cycling capability
- Simple mounting and easy maintenance
- Space and weight saving

Typical Applications

- AC/DC Motor drives
- Various rectifiers
- Soft start AC motor control
- Welding power supply
- DC supply for PWM inverter
- Battery DC chargers or dischargers
- Supplies for DC power equipment



Notes

- All data apply to single diode
- All thermal resistance apply to single diode

Type	V_{RRM}	$I_{T(AV)}$	I_{FSM}	I_{RRM}	V_{FM}/I_{FM}	V_{FO}	r_F	$R_{th(j-c)}$	V_{iso}	T_{jm}	Outline
	150°C	T_c 100°C	10ms	150°C	25°C, Max	150°C		per chip	V	°C	
	V	A	kA	mA	V/A	V	m.ohm	°C/W	V	°C	Fig.
MDx26	600-1800	26	0.65	8	1.34/80	0.80	6.8	1.30	3000	150	M01
MDx40	600-1800	40	1	8	1.47/120	0.80	5.57	0.90	3000	150	M01
MDx55	600-1800	55	1.3	8	1.39/170	0.80	3.47	0.7	3000	150	M01
MDx70	600-1800	70	1.8	8	1.33/210	0.80	2.5	0.57	3000	150	M01
MDx90	600-1800	90	2.3	8	1.38/270	0.80	1.7	0.47	3000	150	M01
MDx110	600-1800	110	2.6	10	1.45/330	0.80	1.74	0.35	3000	150	M01
MDx135	600-1800	135	3.9	12	1.38/410	0.80	1.18	0.31	3000	150	M02
MDx160	600-1800	160	4.6	12	1.45/480	0.80	1.35	0.23	3000	150	M02
MDx182	600-1800	182	6.4	12	1.43/550	0.80	0.96	0.22	3000	150	M02
MDx200	600-1800	200	7.5	12	1.38/600	0.75	0.88	0.21	3000	150	M02
MDx250	600-1800	250	9.5	20	1.35/750	0.75	0.76	0.14	3000	150	M03
MDx300	600-1800	300	9.5	20	1.35/900	0.75	0.55	0.13	3000	150	M03
MDx380	600-1800	380	9.5	20	1.40/1100	0.72	0.4	0.12	3000	150	M03
MDx400	600-1800	400	13	30	1.48/1200	0.75	0.5	0.10	3000	150	M05
MD400	600-1800	400	13	30	1.52/1500	0.75	0.5	0.10	3000	150	M06
MD500	600-1800	500	16	30	1.45/1500	0.75	0.3	0.09	3000	150	M06
MD600	600-1800	600	19	30	1.35/1500	0.75	0.35	0.065	3000	150	M06
MDx500	600-1800	500	16	30	1.32/1500	0.75	0.3	0.09	3000	150	M07
MDx570	600-1800	570	18	30	1.45/1800	0.75	0.3	0.075	3000	150	M07

Type	V _{RRM}	I _{F(AV)}	I _{FSM}	I _{RRM}	V _{FM} /I _{FM}	V _{FO}	r _F	R _{th(j-c)}	V _{iso}	T _{jm}	Outline
	150°C	T _c 100°C	10ms	150°C	25°C, Max	150°C		per chip			
	V	A	kA	mA	V/A	V	m.ohm	°C/W	V	°C	
MDx600	600-1800	600	19	30	1.50/1800	0.75	0.35	0.065	3000	150	M07
MD600	600-1800	600	19	30	1.50/1800	0.75	0.35	0.065	3000	150	M09
MDx800	600-1800	800	22	40	1.80/3000	0.72	0.18	0.058	3000	150	M08
MDx1000	600-1800	1000	28	40	1.82/3000	0.71	0.1	0.052	3000	150	M08
MD1000	600-1800	1000	28	15	1.82/3000	0.71	0.1	0.052	3000	150	M09
MDx1000	600-1800	1000	28	45	1.82/3000	0.71	0.1	0.052	3000	150	M10
MDx1200	600-1800	1200	34	45	1.76/3000	0.71	0.11	0.040	3000	150	M10

Type	V _{RRM}	I _{F(AV)}	I _{FSM}	I _{RRM}	V _{FM} /I _{FM}	V _{FO}	r _F	R _{th(j-c)}	V _{iso}	T _{jm}	Outline
	150°C	T _c 100°C	10ms	150°C	25°C, Max	150°C		per chip			
	V	A	kA	mA	V/A	V	m.ohm	°C/W	V	°C	
MDx26	1900-2500	26	0.65	8	1.44/80	0.85	5.94	1.30	3000	150	M01
MDx40	1900-2500	40	1	8	1.50/120	0.85	4.50	0.90	3000	150	M01
MDx55	1900-2500	55	1.3	8	1.55/170	0.85	3.76	0.68	3000	150	M01
MDx70	1900-2500	70	1.8	8	1.50/210	0.85	2.73	0.55	3000	150	M01
MDx90	1900-2500	90	2.3	8	1.43/270	0.85	1.88	0.45	3000	150	M01
MDx110	1900-2500	110	2.6	8	1.55/330	0.85	1.80	0.33	3000	150	M01
MDx135	1900-2500	135	3.9	12	1.41/410	0.83	1.23	0.30	3000	150	M02
MDx160	1900-2500	160	4.6	12	1.47/480	0.84	1.31	0.23	3000	150	M02
MDx182	1900-2500	182	6.4	12	1.53/550	0.85	1.05	0.20	3000	150	M02
MDx200	1900-2500	200	7.5	12	1.48/600	0.82	0.96	0.18	3000	150	M02
MDx250	1900-2500	250	9.5	20	1.43/750	0.85	0.89	0.13	3000	150	M03
MDx300	1900-2500	300	10	20	1.45/900	0.80	0.5	0.12	3000	150	M03
MDx350	1900-2500	350	12	30	1.60/1200	0.80	0.56	0.11	3000	150	M05
MDx400	1900-2500	400	13	30	1.55/1200	0.85	0.49	0.09	3000	150	M05
MD400	1900-2500	400	13	30	1.40/1500	0.85	0.49	0.09	3000	150	M06
MD500	1900-2500	500	16	30	1.35/1500	0.85	0.38	0.075	3000	150	M06
MDx500	1900-2500	500	16	40	1.60/1800	0.85	0.38	0.075	3000	150	M07
MDx570	1900-2500	570	18	40	1.55/1800	0.75	0.30	0.075	3000	150	M07

Type	V _{RRM}	I _{F(AV)}	I _{FSM}	I _{RRM}	V _{FM} /I _{FM}	V _{FO}	r _F	R _{th(j-c)}	V _{iso}	T _{jm}	Outline
	150°C	T _c 100°C	10ms	150°C	25°C, Max	150°C		per chip			
	V	A	kA	mA	V/A	V	m.ohm	°C/W	V	°C	
MDx600	1900-2500	600	19	40	1.53/1800	0.75	0.32	0.065	3000	150	M07
MDx800	1900-2500	800	22	45	2.00/3000	0.70	0.20	0.058	3000	150	M08
MDx1000	1900-2500	1000	28	45	1.90/3000	0.71	0.10	0.052	3000	150	M08/09/10
MDx1200	1900-2500	1200	34	50	1.85/3000	0.70	0.10	0.042	3000	150	M09/10

Type	V _{RRM}	I _{F(AV)}	I _{FSM}	I _{RRM}	V _{FM} /I _{FM}	V _{FO}	r _F	R _{th(j-c)}	V _{iso}	T _{jm}	Outline
	150°C	T _c 100°C	10ms	150°C	25°C, Max	150°C		per chip			
	V	A	kA	mA	V/A	V	m.ohm	°C/W	V	°C	
MDx200	2600-3600	200	7.5	25	1.90/750	0.95	1.40	0.15	4000	150	M04
MDx250	2600-3600	250	9.5	25	1.83/750	0.95	0.87	0.13	4000	150	M04
MDx300	2600-3600	300	10	35	2.05/1050	0.95	0.7	0.11	4000	150	M05
MDx350	2600-3600	350	11	35	1.95/1050	0.95	0.4	0.11	4000	150	M05
MDx400	2600-3600	400	13	45	2.05/1500	0.95	0.72	0.075	4000	150	M07
MDx500	2600-3600	500	15	45	1.95/1500	0.95	0.31	0.075	4000	150	M07
MDx500	2600-3600	500	15	50	1.96/1800	0.95	0.31	0.075	4000	150	M08
MDx600	2600-3600	600	17	50	1.86/1800	0.95	0.22	0.065	4000	150	M08
MD600	2600-3600	600	17	70	1.86/1800	0.95	0.22	0.065	4000	150	M09

MDx shows any type of MD、MDC、MDA、MDK

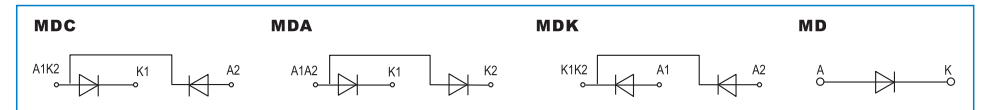

Features

- Isolated mounting base, 3000&4000V~
- International standard package
- Pressure contact technology with increased power cycling capability
- Simple mounting and easy maintenance
- Space and weight saving

Notes

- All data apply to single thyristor or diode
- All thermal resistance apply to single thyristor or diode

Typical Applications

- AC/DC Motor drives
- Various rectifiers
- Heater controls
- Lighting controls
- Contactless switches
- Soft start AC motor control (TSC)SVC
- Welding power supply
- DC supply for PWM inverter
- Battery DC chargers or dischargers
- UPS



Type	V _{DRM} /V _{RRM}	I _{T(AV)}	I _{TSM}	dv/dt	di/dt	I _{DRM} /I _{RRM}	I _{GT}	V _{GT}	I _H	V _{TM} /I _{TM}	V _{TO}	r _T	R _{th(j-c)}	T _{jm}	V _{iso}	Outline Fig.
	125°C	T _c 85°C		125°C		125°C	25°C, Max			125°C	per chip					
	V	A	kA	V/μs	A/μs	mA	mA	V	mA	V/A	V	m.ohm	°C/W	°C	V(AC)	
MFx26	600-1800	26	0.5	1000	200	8	150	2.5	120	1.69/80	0.85	9.68	0.95	125	3000	M01
MFx40	600-1800	40	0.9	1000	200	8	150	2.5	120	1.60/120	0.85	5.57	0.65	125	3000	M01
MFx55	600-1800	55	1.3	1000	200	8	150	2.5	120	1.55/170	0.85	3.47	0.53	125	3000	M01
MFx70	600-1800	70	1.5	1000	200	10	150	2.5	120	1.50/210	0.80	2.64	0.41	125	3000	M01
MFx90	600-1800	90	1.8	1000	200	12	150	2.5	120	1.73/270	0.80	3.01	0.28	125	3000	M01
MFx110	600-1800	110	2.2	1000	200	12	150	2.5	120	1.69/330	0.80	2.29	0.25	125	3000	M01
MFx135	600-1800	135	3.6	1000	200	20	150	2.5	120	1.75/410	0.80	2.60	0.18	125	3000	M02
MFx160	600-1800	160	5.2	1000	200	20	150	2.5	120	1.61/480	0.80	1.69	0.17	125	3000	M02
MFx182	600-1800	182	5.4	1000	200	20	150	2.5	120	1.62/550	0.80	1.26	0.16	125	3000	M02
MFx250	600-1800	250	9	1000	200	25	180	2.5	150	1.57/750	0.80	0.85	0.12	125	3000	M03
MFx285	600-1800	285	9.1	1000	200	25	180	2.5	150	1.45/860	0.80	0.42	0.12	125	3000	M03
MFx300	600-1800	300	9.1	1000	200	25	180	2.5	150	1.56/900	0.80	0.42	0.12	125	3000	M03
MFx330	600-1800	330	9.1	1000	200	25	180	2.5	150	1.45/990	0.80	0.53	0.12	125	3000	M03
MFx350	600-1800	350	11	1000	200	35	180	2.5	150	1.45/1050	0.95	0.36	0.09	125	3000	M05
MFx400	600-1800	400	14.5	1000	200	35	200	3.0	200	1.52/1200	0.80	0.34	0.065	125	3000	M07
MFx500	600-1800	400	14.5	1000	200	35	200	3.0	200	1.44/1500	0.80	0.34	0.065	125	3000	M07
MFx570	600-1800	570	15	1000	200	35	200	3.0	200	1.45/1600	0.80	0.20	0.065	125	3000	M07

Type	V _{DRM} /V _{RRM}	I _{T(AV)}	I _{TSM}	dv/dt	di/dt	I _{DRM} /I _{RRM}	I _{GT}	V _{GT}	I _H	V _{TM} /I _{TM}	V _{TO}	r _T	R _{th(j-c)}	T _{jm}	V _{iso}	Outline Fig.
	125°C	T _c 85°C	10ms	125°C	125°C	25°C, Max			125°C	per chip						
	V	A	kA	V/μs	A/μs	mA	mA	V	mA	V/A	V	m.ohm	°C/W	°C	V(AC)	
MFx600	600-1800	600	16	1000	200	45	200	3.0	200	1.45/1800	0.80	0.28	0.054	125	3000	M08
MFx800	600-1800	800	22	1000	200	45	200	3.0	200	1.86/2400	0.80	0.20	0.042	125	3000	M08
MFx1000	600-1800	1000	28	1000	200	55	200	3.0	200	1.65/3000	0.80	0.15	0.034	125	3000	M10
MFx1200	600-1800	1200	34	1000	200	55	200	3.0	200	1.76/3000	0.80	0.09	0.031	125	3000	M10

Type	V _{DRM} /V _{RRM}	I _{T(AV)}	I _{TSM}	dv/dt	di/dt	I _{DRM} /I _{RRM}	I _{GT}	V _{GT}	I _H	V _{TM} /I _{TM}	V _{TO}	r _T	R _{th(j-c)}	T _{jm}	V _{iso}	Outline Fig.
	125°C	T _c 85°C	10ms	125°C	125°C	25°C, Max			125°C	per chip						
	V	A	kA	V/μs	A/μs	mA	mA	V	mA	V/A	V	m.ohm	°C/W	°C	V(AC)	
MFx26	1900-2500	26	0.48	1000	200	10	150	2.5	150	1.80/80	0.85	9.68	0.95	125	3000	M01
MFx40	1900-2500	40	0.86	1000	200	10	150	2.5	150	1.86/120	0.85	5.57	0.65	125	3000	M01
MFx55	1900-2500	55	1.24	1000	200	10	150	2.5	150	1.98/160	0.85	4.80	0.49	125	3000	M01
MFx70	1900-2500	70	1.43	1000	200	12	150	2.5	150	1.93/210	0.85	3.50	0.39	125	3000	M01
MFx90	1900-2500	90	1.50	1000	200	15	150	2.5	150	1.93/270	0.85	3.26	0.28	125	3000	M01
MFx110	1900-2500	110	1.60	1000	200	15	150	2.5	150	1.95/330	0.85	2.25	0.25	125	3000	M01
MFx135	1900-2500	135	3.6	1000	200	30	150	2.5	150	1.96/410	0.85	1.91	0.20	125	3000	M02
MFx160	1900-2500	160	4.2	1000	200	30	150	2.5	150	1.90/480	0.85	1.53	0.17	125	3000	M02
MFx182	1900-2500	182	4.5	1000	200	30	150	2.5	150	1.84/550	0.85	1.21	0.16	125	3000	M02
MFx200	1900-2500	200	8	1000	200	35	180	2.5	150	1.90/600	0.85	1.14	0.14	125	3000	M03
MFx250	1900-2500	250	9	1000	200	35	180	2.5	150	1.70/750	0.85	0.80	0.12	125	3000	M03
MFx300	1900-2500	300	9.2	1000	200	45	180	2.5	150	1.99/900	0.85	0.65	0.10	125	3000	M03
MFx350	1900-2500	350	11	1000	200	45	180	2.5	150	1.89/1050	0.84	0.50	0.09	125	3000	M05
MFx400	1900-2500	400	12.5	1000	200	45	200	3.0	200	1.92/1500	0.83	0.42	0.08	125	3000	M07
MFx500	1900-2500	500	14.5	1000	200	45	200	3.0	200	2.20/1500	0.85	0.39	0.06	125	3000	M07
MFx600	1900-2500	600	16	1000	200	50	200	3.0	200	1.65/1800	0.88	0.24	0.054	125	3000	M08

Type	V_{DRM}/V_{RRM}	$I_{T(AV)}$	I_{TSM}	dv/dt	di/dt	I_{DRM}/I_{RRM}	I_{GT}	V_{GT}	I_H	V_{TM}/I_{TM}	V_{TO}	r_T	$R_{th(j-c)}$	T_{jm}	V_{iso}	Outline
	125°C	$T_c, 85°C$	10ms	125°C	125°C	25°C, Max			125°C	per chip					Fig.	
	V	A	kA	V/μs	A/μs	mA	mA	V	mA	V/A	V	m.ohm	°C/W	°C	V(AC)	
MFx800	1900-2500	800	22	1000	200	50	200	3.0	200	2.00/2400	0.85	0.17	0.042	125	3000	M08
MFx1000	1900-2500	1000	28	1000	200	60	200	3.0	200	2.10/3000	0.85	0.14	0.034	125	3000	M10
MFx1200	1900-2500	1200	34	1000	200	60	200	3.0	200	2.00/3000	0.85	0.077	0.031	125	3000	M10

Type	V_{DRM}/V_{RRM}	$I_{T(AV)}$	I_{TSM}	dv/dt	di/dt	I_{DRM}/I_{RRM}	I_{GT}	V_{GT}	I_H	V_{TM}/I_{TM}	V_{TO}	r_T	$R_{th(j-c)}$	T_{jm}	V_{iso}	Outline
	125°C	$T_c, 85°C$	10ms	125°C	125°C	25°C, Max			125°C	per chip					Fig.	
	V	A	kA	V/μs	A/μs	mA	mA	V	mA	V/A	V	m.ohm	°C/W	°C	V(AC)	
MFx200	2600-3600	200	8	1000	200	40	180	2.5	150	2.55/600	0.96	1.30	0.12	125	4000	M04
MFx250	2600-3600	250	9	1000	200	55	180	2.5	150	2.63/750	0.91	0.90	0.11	125	4000	M05
MFx300	2600-3600	300	9.2	1000	200	55	180	2.5	150	2.45/900	0.93	1.00	0.08	125	4000	M05
MFx400	2600-3600	400	12.5	1000	200	55	200	3.0	200	2.35/1200	0.98	0.88	0.054	125	4000	M08
MFx500	2600-3600	500	14.5	1000	200	55	200	3.0	200	2.70/1500	0.95	0.51	0.050	125	4000	M08

MFx shows any type of MFC、MFA、MFK

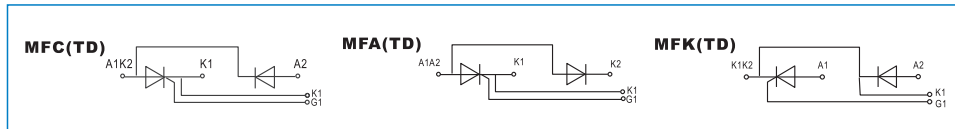

Features

- Non-isolated. Mounting base as common anode or cathode terminal
- International standard package
- Pressure contact technology with increased power cycling capability
- High surge current
- Low forward voltage drop

Typical Applications

- Welding Power Supply
- Various DC power supplies
- DC supply for PWM inverter
- Field supply for DC motors



Notes

- All data apply to single thyristor
- All thermal resistance apply to single thyristor

MTG MTY

Type	V_{DRM}/V_{RRM}	$I_{T(AV)}$	I_{TSM}	dv/dt	di/dt	I_{DRM}/I_{RRM}	I_{GT}	V_{GT}	I_H	V_{TM}/I_{TM}	V_{TO}	r_T	$R_{th(j-c)}$	T_{jm}	Outline
	125°C	$T_c, 90°C$		125°C	125°C	25°C, Max			125°C	per chip				Fig.	
	V	A	kA	V/μs	A/μs	mA	mA	V	mA	V/A	V	m.ohm	°C/W	°C	
MTx50	600-1800	50	1.2	800	100	8	150	2.5	120	1.83/300	0.80	5.41	0.48	125	M12
MTx100	600-1800	100	2.5	800	100	8	150	2.5	120	1.67/300	0.80	2.45	0.25	125	M12
MTx150	600-1800	150	3.9	800	100	12	150	2.5	120	1.80/600	0.80	1.74	0.16	125	M12
MTx200	600-1800	200	5.2	800	100	12	150	2.5	120	1.62/600	0.80	1.15	0.13	125	M12
MTx250	600-1800	250	6.7	800	100	15	150	2.5	120	1.78/900	0.80	1.02	0.10	125	M13
MTx300	600-1800	300	8.3	800	100	15	150	2.5	120	1.58/900	0.80	0.72	0.08	125	M13

MTx shows any type of MTG、MTY

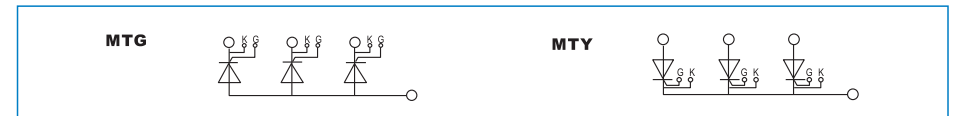

► Diode Modules (Non-isolated type)

Features

- Non-isolated. Mounting base as common anode or cathode terminal
- International standard package
- Pressure contact technology with increased power cycling capability
- Max junction temperature up to 150°C
- High surge current
- Low forward voltage drop

Notes

- All data apply to single diode
- All thermal resistance apply to single diode

Typical Applications

- Welding Power Supply
- Various DC power supplies
- DC supply for PWM inverter
- Field supply for DC motors



MDG MDY

Type	V _{RRM}	I _{F(AV)}	I _{FSM}	I _{RRM}	V _{FM} /I _{FM}	V _{FO}	r _F	R _{th(j-c)}	T _{jm}	Outline Fig.
	150°C	T _c 100°C	10ms	150°C	25°C, Max	150°C		per chip		
	V	A	kA	mA	V/A	V	m.ohm	°C/W	°C	
MDx50	600-1800	50	1.4	6	1.67/300	0.80	4.78	0.70	150	M12
MDx100	600-1800	100	2.8	6	1.57/300	0.80	2.13	0.38	150	M12
MDx150	600-1800	150	4.6	8	1.60/600	0.80	1.53	0.24	150	M12
MDx200	600-1800	200	6.2	8	1.50/600	0.80	0.96	0.20	150	M12
MDx250	600-1800	250	7.8	10	1.60/900	0.80	0.87	0.15	150	M13
MDx300	600-1800	300	10	10	1.50/900	0.80	0.64	0.13	150	M13

MDx shows any type of MDG、MDY

Type	V _{RRM}	I _{F(AV)}	I _{FSM}	I _{RRM}	V _{FM} /I _{FM}	V _{FO}	r _F	R _{th(j-c)}	T _{jm}	Outline Fig.
	150°C	T _c 100°C	10ms	150°C	25°C, Max	150°C		per chip		
	V	A	kA	mA	V/A	V	m.ohm	°C/W	°C	
MDx150	600-1800	150	4.6	8	1.60/600	0.80	1.53	0.24	150	M11
MDx200	600-1800	200	6.2	8	1.50/600	0.80	0.96	0.20	150	M11
MDx250	600-1800	250	7.8	10	1.60/900	0.80	0.87	0.15	150	M14
MDx300	600-1800	300	10	10	1.50/900	0.80	0.64	0.13	150	M14

MDx shows any type of MD(NA)、MD(NK)

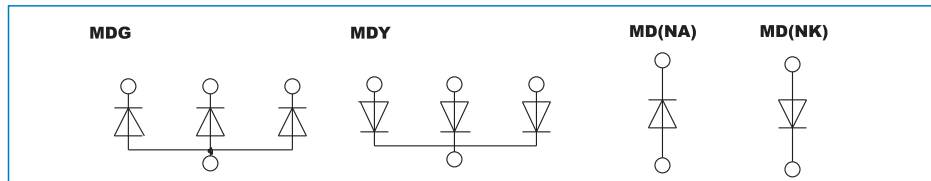

Thyristor / Diode Modules (Non-isolated type) ◀

Features

- Non-isolated. Mounting base as common anode or cathode terminal
- International standard package
- Pressure contact technology with increased power cycling capability
- High surge current
- Low forward voltage drop

Notes

- All data apply to single thyristor or diode
- All thermal resistance apply to single thyristor or diode

Typical Applications

- Welding Power Supply
- Various DC power supplies
- DC supply for PWM inverter
- Field supply for DC motors



MFG MFY

Type	V _{DRM} /V _{RRM}	I _{T(AV)}	I _{TSM}	dv/dt	di/dt	I _{DRM} /I _{RRM}	I _{GT}	V _{GT}	I _H	V _{TM} /I _{TM}	V _{TO}	r _T	R _{th(j-c)}	T _{jm}	Outline Fig.
	125°C	T _c 90°C		125°C		25°C, Max			125°C		per chip				
	V	A	kA	V/μs	A/μs	mA	mA	V	mA	V/A	V	m.ohm	°C/W	°C	
MFX50	600-1800	50	1.2	800	100	8	150	2.5	120	1.83/300	0.80	5.41	0.48	125	M12
MFX100	600-1800	50	2.5	800	100	8	150	2.5	120	1.67/300	0.80	2.45	0.25	125	M12
MFX150	1000-1800	150	3.9	800	100	12	150	2.5	120	1.80/600	0.80	1.74	0.16	125	M12
MFX200	1000-1800	200	5.2	800	100	12	150	2.5	120	1.62/600	0.80	1.15	0.13	125	M12
MFX250	1000-1800	250	6.7	800	100	15	150	2.5	120	1.78/900	0.80	1.02	0.10	125	M13
MFX300	1000-1800	300	8.3	800	100	15	150	2.5	120	1.58/900	0.80	0.72	0.08	125	M13

MFX shows any type of MFG、MFY

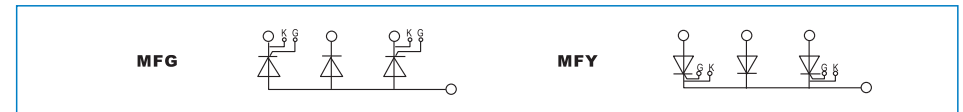

Type	V_{DRM}/V_{RRM}	$I_{T(AV)}$	I_{TSM}	dv/dt	di/dt	I_{DRM}/I_{RRM}	I_{GT}	V_{GT}	I_H	V_{TM}/I_{TM}	V_{TO}	r_T	$R_{th(j-c)}$	T_{jm}	Outline
	125°C	T_c , 90°C	10ms	125°C		25°C, Max			125°C		per chip			Fig.	
	V	A	kA	V/μs	A/μs	mA	mA	V	mA	V/A	V	m.ohm	°C/W	°C	
MTx150	600-1800	150	5.6	800	100	12	100	2.5	120	1.80/600	0.8	1.55	0.17	125	M11
MTx200	600-1800	200	8	800	100	12	100	2.5	120	1.62/600	0.8	1.1	0.13	125	M11
MTx200	600-1800	200	8	800	100	15	100	2.5	120	1.98/900	0.8	1.11	0.13	125	M14
MTx250	600-1800	250	9	800	100	15	100	2.5	120	1.78/900	0.8	0.77	0.11	125	M14
MTx300	600-1800	300	9.2	800	100	15	100	2.5	120	1.58/900	0.8	0.66	0.09	125	M14

MTx shows any type of MT(NA)、MT(NK)

Type	V_{DRM}/V_{RRM}	$I_{T(AV)}$	I_{TSM}	dv/dt	di/dt	I_{DRM}/I_{RRM}	I_{GT}	V_{GT}	I_H	V_{TM}/I_{TM}	V_{TO}	r_T	$R_{th(j-c)}$	T_{jm}	Outline
	125°C	T_c , 90°C	10ms	125°C		25°C, Max			125°C		per chip			Fig.	
	V	A	kA	V/μs	A/μs	mA	mA	V	mA	V/A	V	m.ohm	°C/W	°C	
MTx/MFx400	3700-4200	400	10	800	100	100	200	3.0	200	3.60/1200	0.98	0.64	0.054	125	M05
MTx/MFx800	3700-4200	800	20	800	100	100	200	3.0	200	3.80/2400	0.96	0.16	0.034	125	M08

MTx shows any type of MTC(N)、MTA(N)、MTK(N)
 MFx shows any type of MFC(TDN)、MFA(TDN)、MFK(TDN)、MFC(DTN)、MFA(DTN)、MFK(DTN)

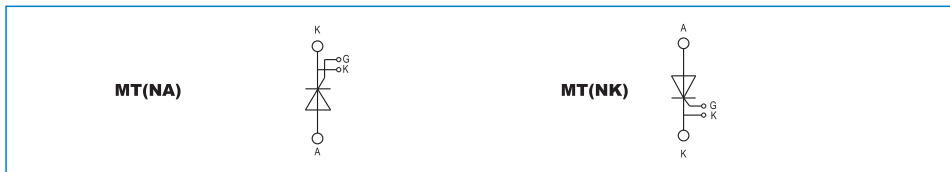
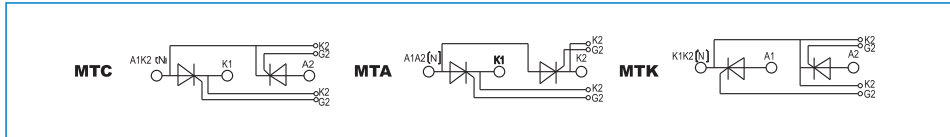

Features

- Isolated mounting base, 2500 V~
- International standard package
- Pressure contact technology with increased power cycling capability
- Simple mounting and easy maintenance
- Space and weight saving

Typical Applications

- Inverter
- Inductive heating
- Chopper



Notes

- All data apply to single thyristor or diode
- All thermal resistance apply to single thyristor or diode

MKX/MHX

Type	V_{DRM}/V_{RRM}	$I_{T(AV)}$ @ T_c	I_{TSM}	dv/dt	di/dt	t_q	I_{DRM}/I_{RRM}	I_{GT}	V_{GT}	I_H	V_{TM}/I_{TM}	V_{TO}	r_T	$R_{th(j-c)}$	V_{iso}	T_{jm}	Outline
	115°C	T_c 85°C	10ms	115°C	100°C	115°C	25°C, Max			115°C		per chip			Fig.		
	V	A	kA	V/μs	A/μs	us	mA	mA	V	mA	V/A	V	m.ohm	°C/W	V	°C	
MHC55	1100/1200	55	1.2	1000	120	12-25	25	150	2.0	250	2.20/230	0.8	4.2	0.40	2500	115	M01
MKx/MHx75	600-1800	75	1.6	800	200	15-35	30	150	2.5	200	2.60/225	0.85	4.88	0.20	2500	115	M02
MKx/MHx150	600-1800	150	3.4	800	200	15-35	50	180	2.5	200	2.25/600	0.85	1.66	0.14	2500	115	M03
MKx/MHx200	600-1800	200	4.8	800	200	15-35	50	180	2.5	200	2.15/600	0.90	1.15	0.10	2500	115	M03
MKx/MHx250	600-1800	250	5.6	800	200	15-35	80	200	3.0	200	2.23/900	0.90	0.98	0.08	2500	115	M05
MKx/MHx300	600-1800	300	7.3	800	200	15-35	80	200	3.0	200	2.15/900	0.90	0.74	0.07	2500	115	M05
MKx/MHx300	600-1800	300	7.3	800	200	15-35	100	200	3.0	200	2.55/1200	0.90	0.74	0.07	2500	115	M08
MKx/MHx400	600-1800	400	7.8	800	200	15-35	100	200	3.0	200	2.40/1200	0.90	0.35	0.06	2500	115	M08
MKx/MHx70	1900-2500	70	1.4	800	200	15-35	30	180	3.0	200	3.20/300	0.95	4.90	0.23	3000	115	M02

MKx shows any type of MKC、MKA、MKK;

MHx shows any type of MHC(KZ)、MHA(KZ)、MHK(KZ)、MHC(ZK)、MHA(ZK)、MHK(ZK)

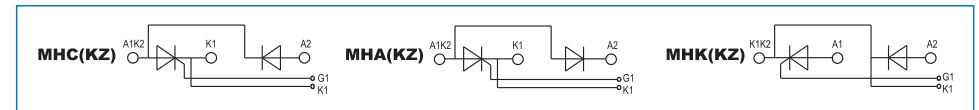
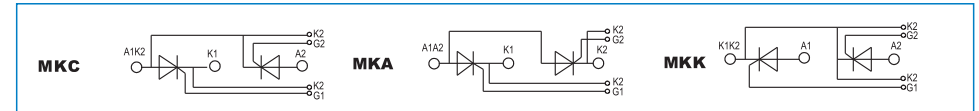

Features

- Isolated mounting base, 2500 V~
- International standard package
- Pressure contact technology with increased power cycling capability
- Simple mounting and easy maintenance
- Space and weight saving

Typical Applications

- Inverter
- Inductive heating
- Chopper



Notes

- All data apply to single thyristor or diode
- All thermal resistance apply to single diode

MZX

Type	V_{DRM}/V_{RRM}	$I_{TAV} @ T_c$	I_{TSM}	I_{RRM}	V_{FM}/I_{FM}	t_{rr}	V_{FO}	r_F	$R_{th(j-c)}$	V_{iso}	T_{jm}	Outline Fig.
	140°C	$T_c 100^\circ C$	140°C		25°C, Max		140°C		per chip			
	V	A	kA	mA	V/A	μs	V	m.ohm	°C/W	V	°C	
MZx75	600-1800	75	2	20	2.20/225	1.5	0.8	4.25	0.31	2500	140	M02
MZx150	600-1800	150	3.8	40	1.85/600	2.0	0.8	1.38	0.21	2500	140	M03
MZx200	600-1800	200	5.5	40	1.77/600	3.0	0.85	0.92	0.15	2500	140	M03
MZx250	600-1800	250	6.2	70	1.83/900	4.0	0.85	0.76	0.12	2500	140	M05
MZx300	600-1800	300	8.3	70	1.75/900	4.0	0.85	0.58	0.10	2500	140	M05
MZx300	600-1800	300	8.3	90	2.15/1200	5.0	0.85	0.58	0.10	2500	140	M08
MZx400	600-1800	400	9.5	90	2.00/1200	5.0	0.85	0.27	0.09	2500	140	M08

MZx shows any type of MZ, MZC, MZA, MZK

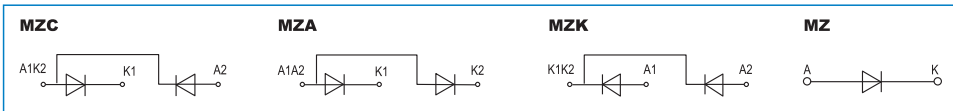

M01

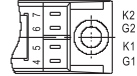
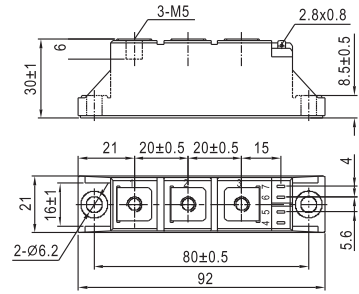

223F3: 4,6 is Gate

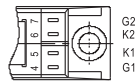

223F3B: 4,7 is Gate

Terminal Torque	4.0N.m	Case Style	223F3
Mounting Torque	6.0N.m	Weight	170g

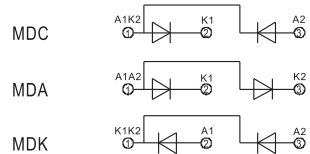
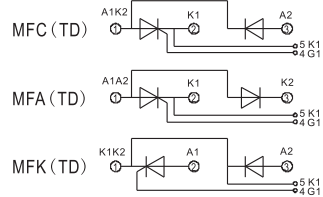
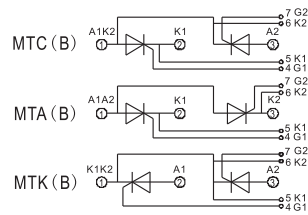
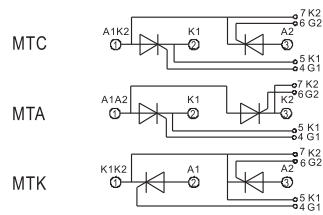

M02

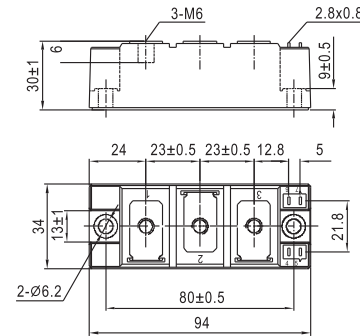

216F3: 4,6 is Gate

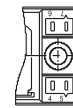

216F3B: 5,7 is Gate

Terminal Torque	6.0N.m	Case Style	216F3
Mounting Torque	6.0N.m	Weight	320g

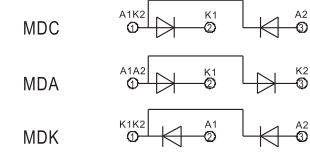
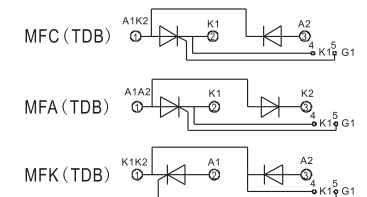
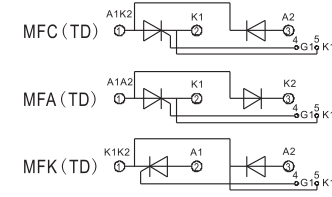
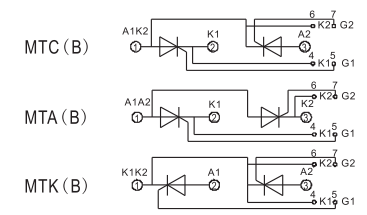
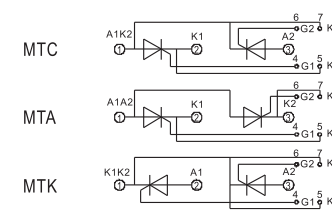

M03

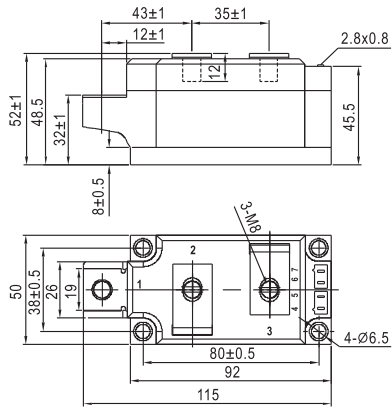

Terminal Torque	12.0N.m	Case Style	413F3D
Mounting Torque	6.0N.m	Weight	810g

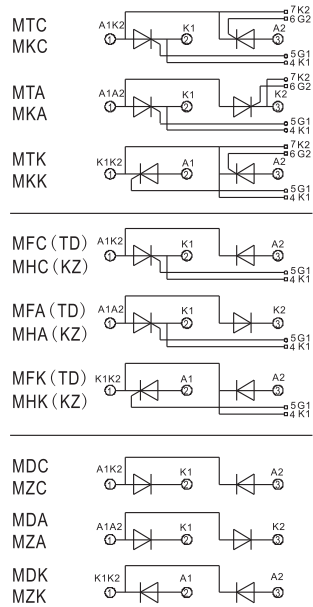

M04

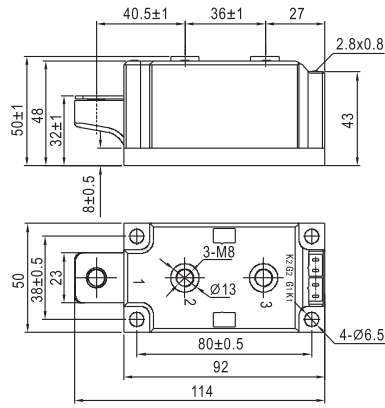

Terminal Torque	12.0N.m	Case Style	413F3
Mounting Torque	6.0N.m	Weight	820g

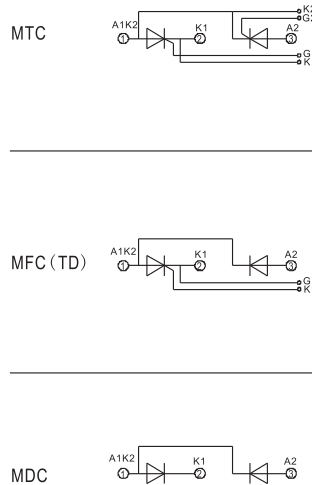

M05

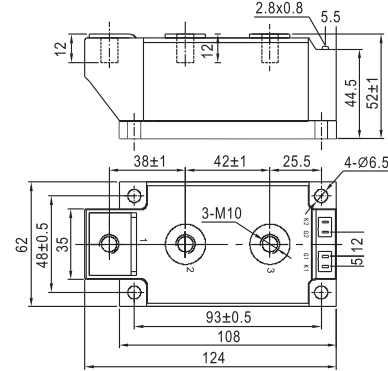

Terminal Torque	12.0N.m	Case Style	415F3
Mounting Torque	6.0N.m	Weight	1275g

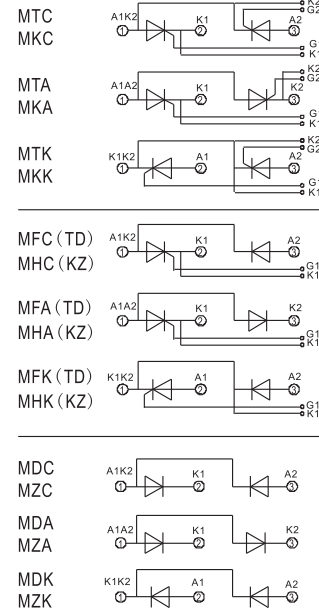

M06

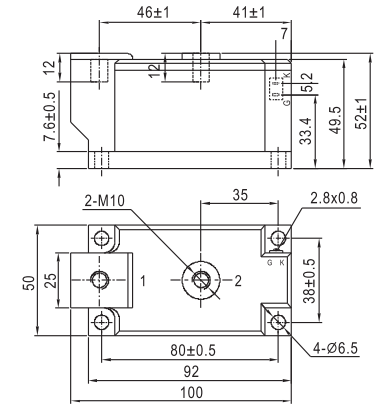

Terminal Torque	12.0N.m	Case Style	417F2
Mounting Torque	6.0N.m	Weight	775g

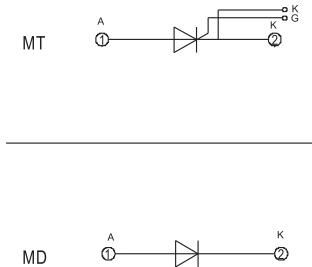

M07

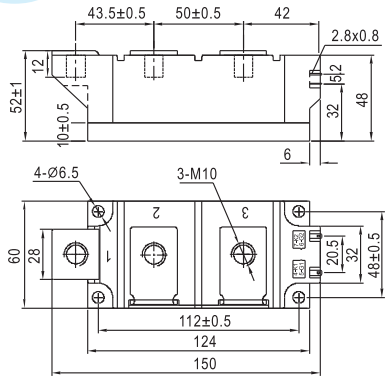

Terminal Torque	12.0N.m	Case Style	416F3
Mounting Torque	6.0N.m	Weight	1500g

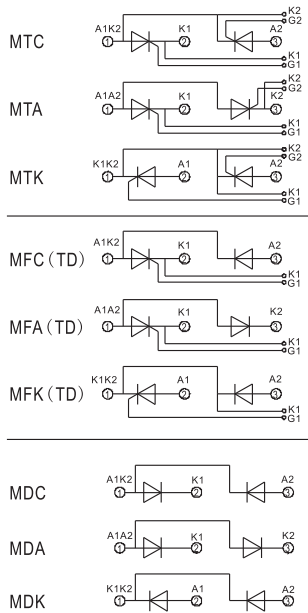

M08

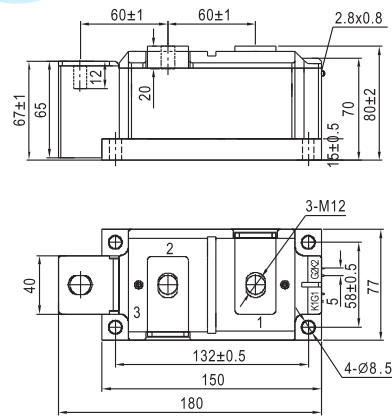

Terminal Torque	14.0N.m	Case Style	410F3
Mounting Torque	12.0N.m	Weight	3240g

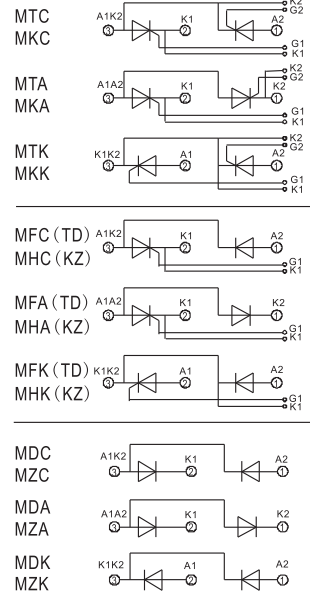

M09

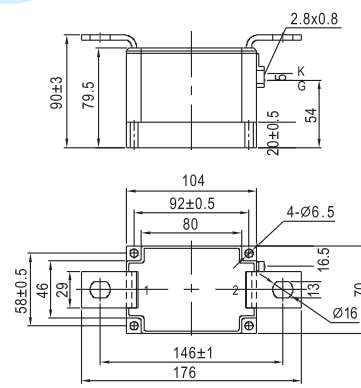

Terminal Torque	12.0N.m	Case Style	432F2
Mounting Torque	6.0N.m	Weight	2700g

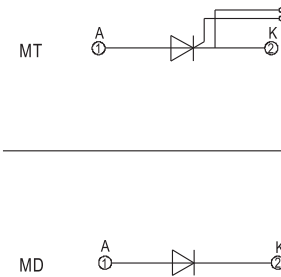

M10

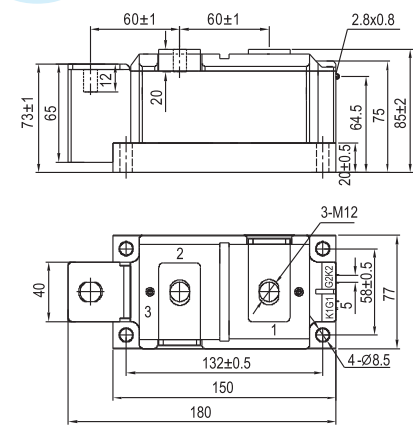

Terminal Torque	14.0N.m	Case Style	412F3
Mounting Torque	12.0N.m	Weight	3660g

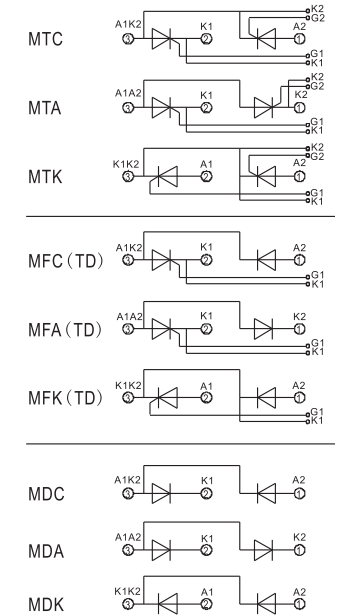

M11

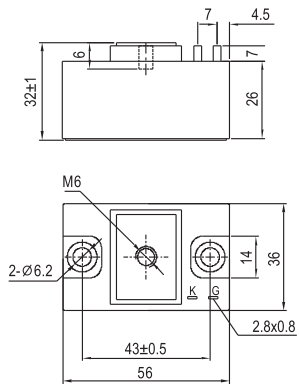

Terminal Torque	6.0N.m	Case Style	210F2
Mounting Torque	6.0N.m	Weight	185g

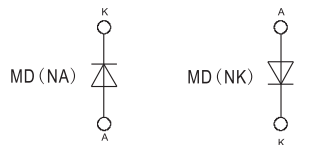
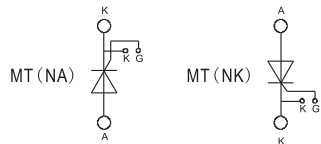

M12

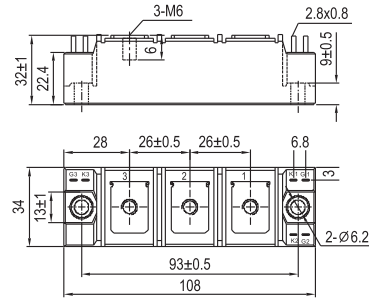

Terminal Torque	6.0N.m	Case Style	213F4
Mounting Torque	6.0N.m	Weight	280g

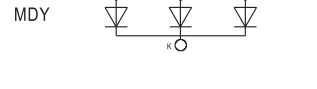
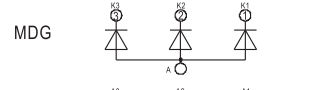
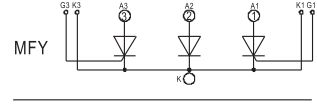
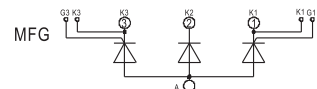
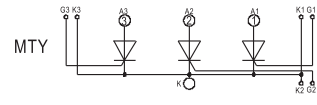
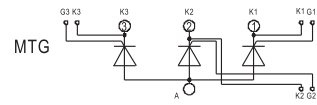

M13

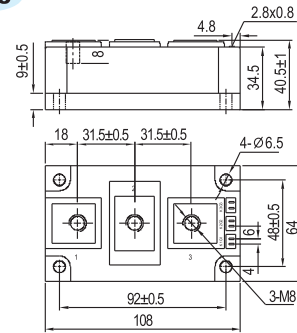

Terminal Torque	12.0N.m	Case Style	404F4
Mounting Torque	6.0N.m	Weight	590g

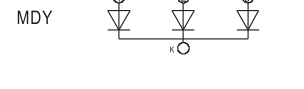
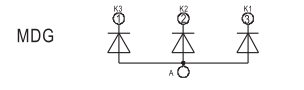
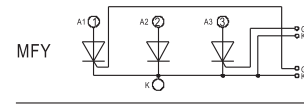
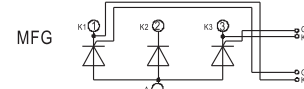
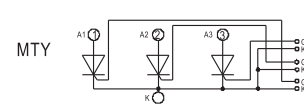
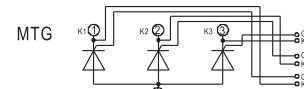

M14

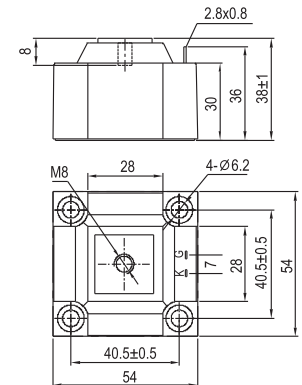

Terminal Torque	12.0N.m	Case Style	407F2
Mounting Torque	6.0N.m	Weight	330g

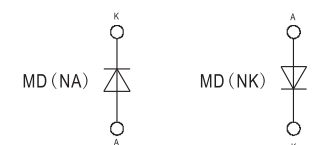
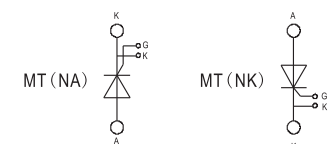

M15

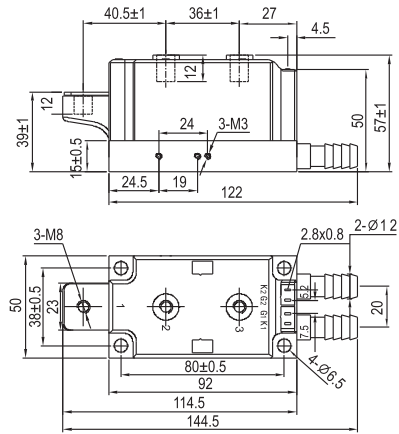

Terminal Torque	12.0N.m	Case Style	405F3
Mounting Torque	6.0N.m	Weight	1055g

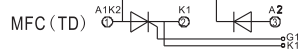
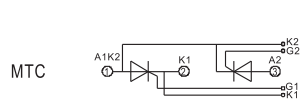

M16

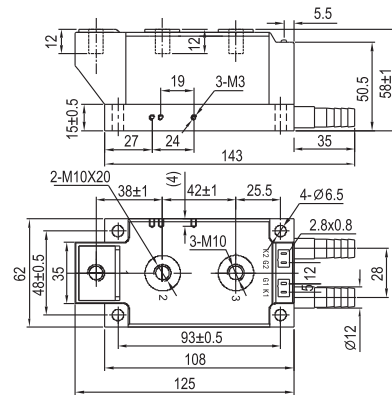

Terminal Torque	12.0N.m	Case Style	406F3
Mounting Torque	6.0N.m	Weight	1560g

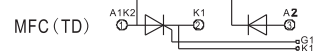
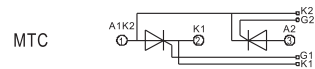

M17

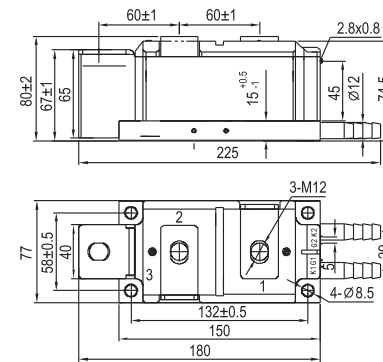

Terminal Torque	14.0N.m	Case Style	411F3
Mounting Torque	12.0N.m	Weight	3460g

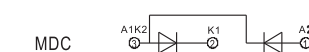
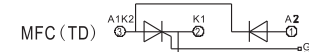
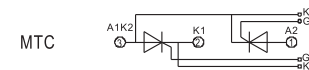



Power Modules (Soldering Modules)

Features

- Isolated mounting base, 3000V~
- International standard package
- Solder joint technology with increased power cycling capability
- Simple mounting and easy maintenance
- Space and weight saving
- Max junction temperature up to 125°C
- Low forward voltage drop

Notes

- All data apply to single thyristor
- All thermal resistance apply to single thyristor

Typical Applications

- AC/DC Motor drives
- Various rectifiers
- Heater controls
- Lighting controls
- Contactless switches
- Soft start AC motor control (TSC)SVC
- Welding power supply
- DC supply for PWM inverter
- Battery DC chargers or dischargers
- UPS



MT/MF

Type	V_{DRM}/V_{RRM}	$I_{T(AV)}$	I_{TSM}	I^2t	dv/dt	di/dt	I_{DRM}/I_{RRM}	I_{GT}	V_{GT}	I_H	V_{TM}/I_{TM}	V_{TO}	r_T	$R_{th(j-c)}$	T_{jm}	V_{iso}	Outline
	125°C/25°C	$T_c, 85^\circ\text{C}$	10ms		125°C			25°C				125°C	per chip	$^\circ\text{C/W}$	$^\circ\text{C}$	V	
	V	A	kA	kA'S	V/ μs	A/ μs	mA	mA	V	mA	V/A	V	m.ohm	$^\circ\text{C/W}$	$^\circ\text{C}$	V	
MTx/MFx26	600-1800	26	1.6	12.8	1000	200	15	30-200	0.6-2.5	10-250	1.55/80	0.75	7.68	0.9	125	3000	H01
MTx/MFx55	600-1800	55	1.7	14.5	1000	200	15	30-200	0.6-2.5	10-250	1.6/170	0.75	4.05	0.47	125	3000	H01
MTx/MFx70	600-1800	70	1.8	16.2	1000	200	15	30-200	0.6-2.5	10-250	1.65/210	0.75	3.64	0.35	125	3000	H01
MTx/MFx90	600-1800	90	1.9	18.1	1000	200	20	30-200	0.6-2.5	10-250	1.7/270	0.7	3.01	0.28	125	3000	H01
MTx/MFx110	600-1800	110	1.9	20.0	1000	200	20	30-200	0.6-2.5	10-250	1.75/330	0.8	2.29	0.25	125	3000	H01
MTx/MFx135	600-1800	135	3.5	61.3	1000	200	35	30-200	0.6-2.5	10-250	1.6/410	0.95	1.5	0.18	125	3000	H02
MTx/MFx160	600-1800	160	3.8	72.2	1000	200	40	30-200	0.6-2.5	10-250	1.65/480	0.85	1.5	0.17	125	3000	H02
MTx/MFx182	600-1800	182	4	80	1000	200	40	30-200	0.6-2.5	10-250	1.7/550	0.83	1.3	0.16	125	3000	H02

MTC

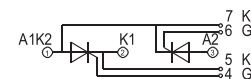

MT

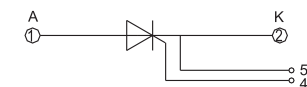

MFC(TD)

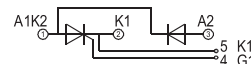

Features

- Isolated mounting base, 3000V~
- International standard package
- Solder joint technology with increased power cycling capability
- Simple mounting and easy maintenance
- Space and weight saving
- Max junction temperature up to 150°C
- Low forward voltage drop

Notes

- All data apply to single diode
- All thermal resistance apply to single diode

Typical Applications

- Various rectifiers
- Soft start AC motor control
- Welding power supply
- DC supply for PWM inverter
- Battery DC chargers or dischargers
- Supplies for DC power equipment



MD

Type	V_{RRM}	$I_{F(AV)}$	I_{FSM}	I^2t	I_{RRM}	V_{FM}/I_{FM}	V_{FO}	r_F	$R_{th(j-c)}$	T_{jm}	V_{iso}	Outline
	150°C / 25°C	T_c 100°C	10ms		150°C	25°C	150°C		per chip			
	V	A	kA	kA ² S	mA	V/A	V	m.ohm	°C/W	°C	V(AC)	
MDx26	600-1800	26	1.7	14.5	8	1.35/80	0.8	6.80	1.35	150	3000	H01
MDx55	600-1800	55	1.8	16.2	8	1.4/170	0.8	3.74	0.7	150	3000	H01
MDx70	600-1800	70	1.9	18.1	8	1.45/210	0.8	2.5	0.57	150	3000	H01
MDx90	600-1800	90	2	20.0	8	1.50/270	0.8	1.7	0.47	150	3000	H01
MDx110	600-1800	110	2	24.2	8	1.55/330	0.8	1.74	0.35	150	3000	H01
MDx135	600-1800	135	3.8	72.2	12	1.45/410	0.85	1.35	0.22	150	3000	H02
MDx160	600-1800	160	4	80	12	1.50/480	0.85	1.25	0.2	150	3000	H02
MDx182	600-1800	182	4	84.1	12	1.55/550	0.83	1.2	0.19	150	3000	H02
MDx200	600-1800	200	4	92.5	12	1.60/600	0.78	1.1	0.18	150	3000	H02

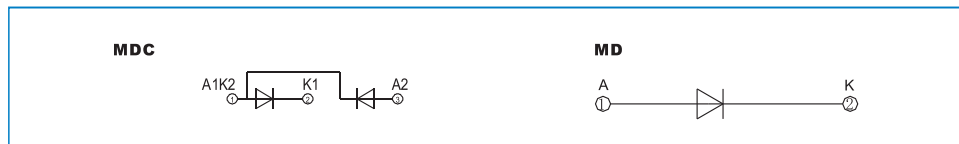

Features

- Isolated mounting base, 2500 V~
- International standard package
- Solder joint technology with increased power cycling capability
- Simple mounting and easy maintenance
- Space and weight saving
- Max junction temperature up to 150°C
- Low forward voltage drop

Notes

- All data apply to single diode
- All thermal resistance apply to total module

Typical Applications

- Supplies for DC power equipment
- DC supply for PWM inverter
- Battery DC power supplies
- Field supply for DC motors
- Soft start Capacitor Charging
- Electric drives and auxiliaries
- Inverter welder
- Input rectifier for switch mode power supplies(SMPS)



MDQ

Type	V_{RRM}	I_o	I_{FSM}	I^2t	I_{RRM}	V_{FM}/I_{FM}	V_{FO}	r_F	$R_{th(j-c)}$	T_{jm}	V_{iso}	Outline
		T_c 100°C	10ms		150°C	25°C	150°C		total			
	V	A	kA	kA ² S	mA	V/A	V	m.ohm	°C/W	°C	V(AC)	
MDQ50	600-1800	50	0.5	1.8	8	1.25/75	0.70	6.0	0.24	150	2500	H03/05/07/09
MDQ75	600-1800	75	0.6	3.2	8	1.38/120	0.70	4.2	0.20	150	2500	H03/05/07/09
MDQ100	600-1800	100	1.3	8.6	12	1.40/150	0.75	2.4	0.14	150	2500	H11/113/15
MDQ150	600-1800	150	1.5	16.5	12	1.55/230	0.75	1.9	0.10	150	2500	H11/113/15

MDS

Type	V_{RRM}	I_o	I_{FSM}	I^2t	I_{RRM}	V_{FM}/I_{FM}	V_{FO}	r_F	$R_{th(j-c)}$	T_{jm}	V_{iso}	Outline
		T_c 100°C	10ms		150°C	25°C	150°C		total			
	V	A	kA	kA ² S	mA	V/A	V	m.ohm	°C/W	°C	V(AC)	
MDS50	600-1800	50	0.4	0.80	8	1.20/50	0.70	6.0	0.30	150	2500	H04/06/08/10
MDS75	600-1800	75	0.5	1.80	8	1.25/75	0.70	5.0	0.24	150	2500	H04/06/08/10
MDS100	600-1800	100	0.6	3.20	8	1.30/100	0.70	4.5	0.20	150	2500	H04/06/08/10
MDS150	600-1800	150	1.3	8.60	12	1.40/150	0.75	2.4	0.14	150	2500	H12/14/16
MDS175	600-1800	175	1.4	11.5	12	1.45/175	0.75	2.2	0.12	150	2500	H12/14/16
MDS200	600-1800	200	1.5	14.7	12	1.50/200	0.75	2.0	0.10	150	2500	H12/14/16



Features

- Isolated mounting base, 2500 V~
- International standard package
- Solder joint technology with increased power cycling capability
- Simple mounting and easy maintenance
- Simple design, module and SCR rectifier bridge close 2 for one, small volume, light weight

Typical Applications

- Supplies for DC power equipment
- Field supply for DC motors
- Inverter welder



Notes

- All data apply to single thyristor or diode
- All thermal resistance apply to total module

MDST

Type	Thyristor	V_{DRM}/V_{RRM}	I_D	I_{TSM}	I_{DRM}/I_{RRM}	I_{GT}	V_{GT}	I_H	V_{TM}/I_{TM}	V_{TO}	r_T	$R_{th(j-c)}$	T_{jm}	V_{iso}	Outline
	Diode	V_{RRM}		I_{FSM}	I_{RRM}	\	\	\	V_{FM}/I_{FM}	V_{FO}	r_F				
			$T_c, 100^\circ\text{C}$	10ms	125°C	25°C			125°C			total			
		V	A	kA	mA	mA	V	mA	V/A	V	m.ohm	°C/W	°C	V(AC)	
MDST50	Thyristor	600-1800	50	0.4	15	30~200	0.6~2.5	10~250	1.55/150	0.85	4.3	0.80	125	2500	H17
	Diode	600-1800	50	0.4	8	/	/	/	1.20/50	0.85	4.3	0.30	125		
MDST75	Thyristor	600-1800	75	0.5	15	30~200	0.6~2.5	10~250	1.60/230	0.85	3.1	0.40	125	2500	H17
	Diode	600-1800	75	0.5	8	/	/	/	1.25/75	0.85	3.1	0.25	125		
MDST100	Thyristor	600-1800	100	0.6	20	30~200	0.6~2.5	10~250	1.65/300	0.85	2.3	0.36	125	2500	H17
	Diode	600-1800	100	0.6	8	/	/	/	1.30/100	0.85	2.3	0.20	125		
MDST150	Thyristor	600-1800	150	1.3	40	30~200	0.6~2.5	10~250	1.65/450	0.85	1.6	0.20	125	2500	H18
	Diode	600-1800	150	1.3	8	/	/	/	1.40/150	0.85	1.6	0.15	125		
MDST200	Thyristor	600-1800	200	1.5	40	30~200	0.6~2.5	10~250	1.75/600	0.85	1.2	0.12	125	2500	H18
	Diode	600-1800	200	1.5	8	/	/	/	1.50/200	0.85	1.2	0.10	125		

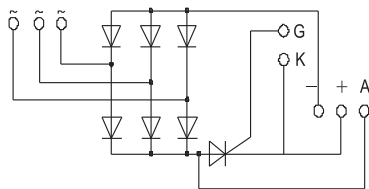

Features

- Super fast recovery
- Max junction temperature up to 175°C
- Low forward voltage drop

Typical Applications

- Inverter welding power supply
- Power supply for telecommunication
- Various switching power supply



Notes

- V_{FM} are for 25°C, others are for $T_j=T_{jm}$, unless stated otherwise.

Type	$I_{F(AV)}$	V_{RRM}	I_{RRM}		I_{FRM}	I_{FSM}	V_{FM}	t_{rr}	$R_{th(j-c)}$	T_j	Outline
	A	V	μA	μA	A	A	V	ns	°C/W	°C	
			125°C	25°C	20 kHz $T_c 95^\circ\text{C}$	Per Leg 10ms	Per Leg 25°C	25°C	Per Leg		Fig.
MUR20020	200 ($T_c = 130^\circ\text{C}$)	200	1000	150	200	800	1.00/100	50	0.45	-55 ~ +175	H19
MUR20040	200 ($T_c = 100^\circ\text{C}$)	400	500	50	200	800	1.30/100	75	0.45	-55 ~ +175	H19
MUR40040	400 ($T_c = 100^\circ\text{C}$)	400	1000	100	400	3500	1.15/200	50	0.15	-55 ~ 150	H20

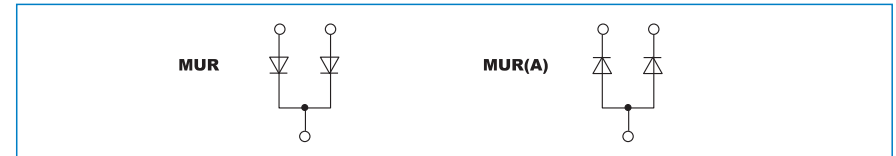



H01

Terminal Torque	4.0N.m	Case Style	224H3B
Mounting Torque	6.0N.m	Weight	95g

MTC(B)

Terminal Torque	4.0N.m	Case Style	224H3
Mounting Torque	6.0N.m	Weight	95g

MTC

MFC (TD)

MDC

H02

Terminal Torque	6.0N.m	Case Style	229H3B
Mounting Torque	6.0N.m	Weight	190g

MTC(B)

MFC (TDB)

Terminal Torque	6.0N.m	Case Style	229H3
Mounting Torque	6.0N.m	Weight	190g

MTC

MFC (TD)

MDC

H03

Technical drawing of power module H03. Side view shows a height of 11.6 mm and a mounting tab height of 30.0 mm. Top view shows a width of 72 mm and a terminal pitch of 20.0 mm. Dimensions include 23±0.5 mm for terminal spacing, 60±0.3 mm for the main body width, and 42 mm for the terminal height. A 4-M5 screw is used for mounting. The circuit diagram shows a full-bridge rectifier with AC input and DC output (+ and -).

Terminal Torque	4.0N.m	Case Style	232H5
Mounting Torque	4.0N.m	Weight	120g

H04

Technical drawing of power module H04. Side view shows a height of 11.6 mm and a mounting tab height of 30.0 mm. Top view shows a width of 72 mm and a terminal pitch of 20.0 mm. Dimensions include 23±0.5 mm for terminal spacing, 60±0.3 mm for the main body width, and 42 mm for the terminal height. A 5-M5 screw is used for mounting. The circuit diagram shows a full-bridge rectifier with AC input and DC output (+ and -).

Terminal Torque	4.0N.m	Case Style	232H5
Mounting Torque	4.0N.m	Weight	135g

H07

Technical drawing of power module H07. Side view shows a height of 10.5 mm and a mounting tab height of 32.5 mm. Top view shows a width of 80 mm and a terminal pitch of 16.5 mm. Dimensions include 16.5±0.5 mm for terminal spacing, 66±0.3 mm for the main body width, and 40 mm for the terminal height. A 4-M5 screw is used for mounting. The circuit diagram shows a full-bridge rectifier with AC input and DC output (+ and -).

Terminal Torque	4.0N.m	Case Style	219H5
Mounting Torque	6.0N.m	Weight	135g

H08

Technical drawing of power module H08. Side view shows a height of 10.5 mm and a mounting tab height of 32.5 mm. Top view shows a width of 80 mm and a terminal pitch of 16.5 mm. Dimensions include 16.5±0.5 mm for terminal spacing, 66±0.3 mm for the main body width, and 40 mm for the terminal height. A 5-M5 screw is used for mounting. The circuit diagram shows a full-bridge rectifier with AC input and DC output (+ and -).

Terminal Torque	4.0N.m	Case Style	219H5
Mounting Torque	6.0N.m	Weight	150g

H05

Technical drawing of power module H05. Side view shows a height of 10.5 mm and a mounting tab height of 27.0 mm. Top view shows a width of 80 mm and a terminal pitch of 18.0 mm. Dimensions include 18±0.5 mm for terminal spacing, 66±0.3 mm for the main body width, and 40 mm for the terminal height. A 4-M5 screw is used for mounting. The circuit diagram shows a full-bridge rectifier with AC input and DC output (+ and -).

Terminal Torque	4.0N.m	Case Style	218H5
Mounting Torque	6.0N.m	Weight	135g

H06

Technical drawing of power module H06. Side view shows a height of 10.5 mm and a mounting tab height of 27.0 mm. Top view shows a width of 80 mm and a terminal pitch of 18.0 mm. Dimensions include 18±0.5 mm for terminal spacing, 66±0.3 mm for the main body width, and 40 mm for the terminal height. A 5-M5 screw is used for mounting. The circuit diagram shows a full-bridge rectifier with AC input and DC output (+ and -).

Terminal Torque	4.0N.m	Case Style	218H5
Mounting Torque	6.0N.m	Weight	150g

H09

Technical drawing of power module H09. Side view shows a height of 10.5 mm and a mounting tab height of 22.0 mm. Top view shows a width of 80 mm and a terminal pitch of 20.0 mm. Dimensions include 20±0.5 mm for terminal spacing, 66±0.3 mm for the main body width, and 40 mm for the terminal height. A 4-M5 screw is used for mounting. The circuit diagram shows a full-bridge rectifier with AC input and DC output (+ and -).

Terminal Torque	4.0N.m	Case Style	220H5
Mounting Torque	4.0N.m	Weight	135g

H10

Technical drawing of power module H10. Side view shows a height of 10.5 mm and a mounting tab height of 22.0 mm. Top view shows a width of 80 mm and a terminal pitch of 20.0 mm. Dimensions include 20±0.5 mm for terminal spacing, 66±0.3 mm for the main body width, and 40 mm for the terminal height. A 5-M5 screw is used for mounting. The circuit diagram shows a full-bridge rectifier with AC input and DC output (+ and -).

Terminal Torque	4.0N.m	Case Style	220H5
Mounting Torque	4.0N.m	Weight	150g

H11

Terminal Torque	4.0N.m	Case Style	221H5
Mounting Torque	6.0N.m	Weight	235g

H12

Terminal Torque	4.0N.m	Case Style	221H5
Mounting Torque	6.0N.m	Weight	250g

H15

Terminal Torque	6.0N.m	Case Style	234H5
Mounting Torque	6.0N.m	Weight	230g

H16

Terminal Torque	6.0N.m	Case Style	234H5
Mounting Torque	6.0N.m	Weight	250g

H13

Terminal Torque	6.0N.m	Case Style	411H5
Mounting Torque	4.0N.m	Weight	310g

H14

Terminal Torque	6.0N.m	Case Style	411H5
Mounting Torque	4.0N.m	Weight	330g

H17

Terminal Torque	4.0N.m	Case Style	225H6
Mounting Torque	6.0N.m	Weight	215g

H18

Terminal Torque	6.0N.m	Case Style	421H6
Mounting Torque	6.0N.m	Weight	280g

► Outline

H19

MUR MUR (A)

Terminal Torque	3.0N.m	Case Style	302H3
Mounting Torque	6.0N.m	Weight	80g

H20

MUR

Terminal Torque	6.0N.m	Case Style	235H3
Mounting Torque	6.0N.m	Weight	96g



IGBT Modules



Features

- Isolated mounting base, 2500V~
- International standard package
- Solder joint technology with increased power cycling capability
- Simple mounting and easy maintenance
- Space and weight saving
- Max junction temperature up to 175°C
- Low forward voltage drop

Typical Applications

- Frequency transformer
- UPS
- Welding power supply



Notes

- All data apply to per IGBT
- All thermal resistance apply to per IGBT

Type	IGBT						Diode			Outline
	V _{CE(sat)}	I _C	V _{CE(EMT)}	E _{on}	E _{off}	R _{th(j-c)}	V _F	E _{rr}	R _{th(j-c)}	
	25°C	T _c =80°C	25°C	125°C		per IGBT	25°C	125°C	per Diode	
	V	A	V	mJ	mJ	°C/W	V	mJ	°C/W	
MGC50D12A1	1200	50	2.3	3.3	5.7	0.54	2.5	2.6	0.97	G01
MGC75D12A1	1200	75	2.3	6.5	9.3	0.43	2.5	4.5	0.80	
MGC100D12A1	1200	100	2.4	12.5	11.0	0.30	2.6	5.5	0.50	
MGC150D12A1	1200	150	2.4	12.6	16.5	0.21	2.6	7.7	0.31	
MGC150D12A1	1200	150	2.4	15.5	18.8	0.19	2.6	8.5	0.28	G02
MGC200D12A1	1200	200	2.5	30.2	27.2	0.17	2.6	9.7	0.26	
MGC300D12A1	1200	300	2.4	27.5	34.5	0.11	2.6	17.2	0.16	
MGC400D12A1	1200	400	2.5	63.5	56.6	0.089	2.6	23.4	0.068	

G01

Technical drawing showing dimensions for G01: 2-Ø6.5, 3-M5, 2.8x0.5, 10, 6, 22, 29.5, 30.0, 12, 17, 4, 34, 23±0.5, 23±0.5, 17, 80±0.2, 94. Circuit diagram shows terminals C2E1, E2, C1, E1, G1.

Terminal Torque	4.0N.m	Case Style	251H3
Mounting Torque	6.0N.m	Weight	150g

G02

Technical drawing showing dimensions for G02: 13, 13, 4-Ø6.5, 18.5, 28±0.5, 28±0.5, 20, 3-M6, 3, 15, 27, 30, 48±0.3, 61.4, 93±0.3, 106.4, 13.3, 13.3. Circuit diagram shows terminals 1, 2, 3, 4, 5.

Terminal Torque	6.0N.m	Case Style	454H3
Mounting Torque	6.0N.m	Weight	320g

► Insulated Gate Bipolar Transistor

Features

- Isolated mounting base, 2500V~
- International standard package
- Solder joint technology with increased power cycling capability
- Simple mounting and easy maintenance
- Space and weight saving
- Max junction temperature up to 175°C
- Low forward voltage drop

Typical Applications

- Inverter for Motor Drive
- AC and DC Servo Drive Amplifier
- Uninterruptible Power Supply
- Industrial Machines

Notes

- All data apply to per IGBT
- All thermal resistance apply to per IGBT



Type	IGBT						Diode			Outline
	V _{CE(sat)}	I _C	V _{CE(sat)}	E _{on}	E _{off}	R _{th(j-c)}	V _F	E _{rr}	R _{th(j-c)}	
	25°C	T _c =80°C	25°C	125°C		per IGBT	25°C	125°C	per Diode	
	V	A	V	mJ	mJ	°C/W	V	mJ	°C/W	
MGS75D12A1	1200	75	2.3	6.5	9.3	0.43	2.5	4.5	0.80	G03
MGS100D12A1	1200	100	2.4	12.5	11.0	0.3	2.6	5.5	0.50	
MGS150D12A1	1200	150	2.4	13.8	17.5	0.20	2.6	11.5	0.30	
MGS200D12A1	1200	200	2.5	20.8	25.2	0.15	2.6	11.7	0.22	

G03

Mounting Torque 4.5N.m

Case Style	453H5
Weight	310g

Insulated Gate Bipolar Transistor ◀

Features

- Isolated mounting base, 2500V~
- International standard package
- Solder joint technology with increased power cycling capability
- Simple mounting and easy maintenance
- Space and weight saving
- Max junction temperature up to 175°C
- Low forward voltage drop

Typical Applications

- Inverter for Motor Drive
- AC and DC Servo Drive Amplifier
- Uninterruptible Power Supply
- Industrial Machines

Notes

- All data apply to per IGBT
- All thermal resistance apply to per IGBT

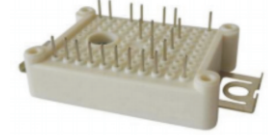

Type	IGBT						Diode			Rectifier		Outline
	V _{CE(sat)}	I _C	V _{CE(sat)}	E _{on}	E _{off}	R _{th(j-c)}	V _F	E _{rr}	R _{th(j-c)}	I _{FSM}	R _{th(j-c)}	
	25°C	T _c =80°C	25°C	125°C		per IGBT	25°C	125°C	per Diode	150°C 10ms	per Diode	
	V	A	V	mJ	mJ	°C/W	V	mJ	°C/W	kA	°C/W	
MPS15D12K1	1200	15	2.7	1.0	1.2	0.80	2.8	0.8	1.8	0.17	2.00	G04
MPS30D12K1	1200	30	2.7	2.7	2.1	0.62	2.5	1.6	1.2	0.25	1.35	G05
MPS40D12K1	1200	40	2.7	2.7	2.1	0.62	2.5	1.6	1.2	0.32	1.35	
MPS40D12K1	1200	40	2.7	4.6	2.4	0.50	2.5	1.6	1.2	0.252	1.35	G06

G04

Mounting Torque 4.0N.m

Case Style	258H5
Weight	23.5g

G05

Mounting Torque 4.0N.m

Case Style	259H5
Weight	64g

► Insulated Gate Bipolar Transistor

G06

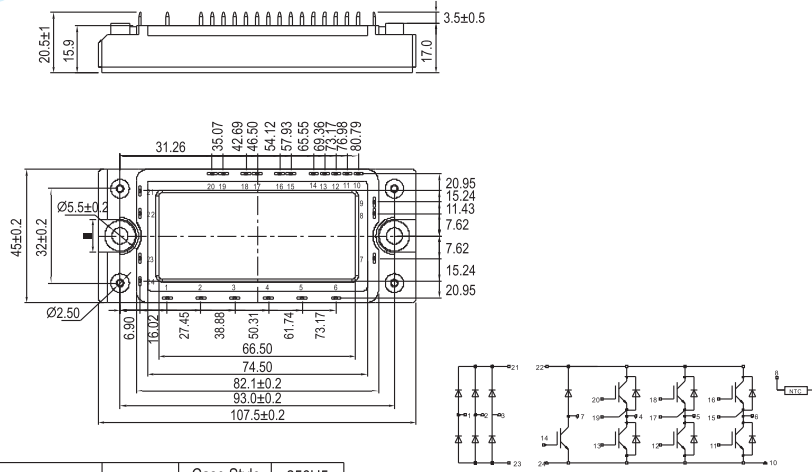

Mounting Torque	4.0N.m	Case Style	256H5
		Weight	190g



Plastic Fast Recovery Diodes

Features

- Planar passivated chips
- Very low leakage current
- Very short recovery time
- Improved thermal behaviour
- Very low I_{rm}-values
- Very soft recovery behaviour

Typical Applications

- Antiparallel diode for high frequency switching devices
- Antisaturation diode
- Snubber diode
- Free wheeling diode
- Rectifiers in switch mode power supplies(SMPS)
- Uninterruptible power supplies(UPS)

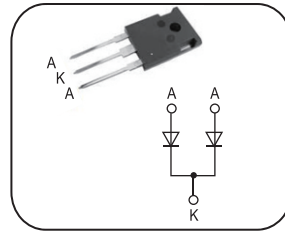

Type	I _F		t _{rr} @		t _{rr} @		V _F @		V _F @		Outline
	A	V	I _F =0.5A, I _R =1A, I _F =0.25A		I _F =1A, di/dt=200A/μs, V _R =30V		I _F =I _F (Per leg), T _a =25°C		I _F =I _F (Per leg), T _a =125°C		
	Spec	Spec	Max	Typ	Max	Typ	Max	Typ	Max	Typ	
MUR01002-TO220FH	2*5	200	35	21	30	17	0.975	0.92	0.85	0.77	F3
MUR01202-TO220FH	2*6	200	35	22	30	18	0.975	0.92	0.85	0.77	F3
MUR01602-TO220FH	2*8	200	25	20	30	22	0.975	0.91	0.875	0.77	F3
MUR02002-TO220FH	2*10	200	35	24	30	20	1.05	0.95	0.95	0.8	F3
MUR03002-TO220FH	2*15	200	35	27	30	21	1.05	0.98	0.95	0.83	F3
MUR02002-TO247	2*10	200	35	27	30	21	1.05	0.98	0.95	0.83	F5
MUR02002-TO3PB	2*10	200	30	25	30	21	0.95	0.9	0.9	0.85	F7
MUR02002-TO3PF	2*10	200	35	27	30	21	1.05	0.98	0.95	0.83	F8
MUR03002-TO247	2*15	200	30	25	30	21	0.95	0.9	0.9	0.85	F5
MUR05002-TO3PB	2*25	200	40	30	35	25	1.05	0.98	0.95	0.83	F7
MUR02003-TO3PF	2*10	300	50	40	40	30	1.2	1	1.1	0.85	F8
MUR06003-TO3PB	2*30	300	45	36	40	28	1.2	1	1.1	0.85	F7
MUR01604-TO220FH	2*8	400	50	40	40	30	1.2	1.05	1.25	0.95	F3
MUR02004-TO3PF	2*10	400	40	30	35	25	1.35	1.15	1.25	1	F8
MUR03004-TO247	2*15	400	40	30	35	25	1.35	1.15	1.25	1	F5
MUR08004-TO3PB	2*40	400	50	35	40	29	1.35	1.1	1.25	0.95	F7
MU00806-TO220M	8	600	50	40	40	30	1.25	1.1	1.25	1	F4
MU00806-TO220FH	8	600	35	25	40	23	1.55	1.25	1.45	1.15	F3
MU01506-TO247AC	15	600	40	27	35	25	1.55	1.35	1.45	1.2	F6
MU01506-TO220AC	15	600	40	27	35	25	1.55	1.35	1.45	1.2	F2
MU01506-TO220FH	15	600	40	27	35	25	1.55	1.35	1.45	1.2	F3
MUR01606-TO220FH	2*8	600	35	26	35	23	1.55	1.25	1.45	1.15	F3

Type	I _{F(A)}		V _{R(V)}		T _{rr(ns)} @		T _{rr(ns)} @		V _{F(V)} @		V _{F(V)} @		Outline
	I _F =0.5A, I _R =1A, I _F =0.25A		I _F =1A, di/dt=200A/μs, V _R =30V		I _F =1A, di/dt=200A/μs, V _R =30V		I _F =I _F (Per leg), T _a =25°C		I _F =I _F (Per leg), T _a =125°C				
	Spec	Spec	Max	Typ	Max	Typ	Max	Typ	Max	Typ			
MU01606-TO247AC	16	600	40	27	35	25	1.55	1.35	1.45	1.2	F6		
MU01606-TO220AC	16	600	40	27	35	25	1.55	1.35	1.45	1.2	F2		
MUR02006-TO3PF	2*10	600	40	27	35	25	1.55	1.35	1.45	1.2	F8		
MU03006-TO247AD	30	600	45	35	40	29	1.55	1.35	1.45	1.2	F5		
MU03006-TO220AB	30	600	45	35	40	29	1.55	1.35	1.45	1.2	F1		
MU03006-TO247AC	30	600	45	35	40	29	1.55	1.35	1.45	1.2	F6		
MU03006-TO220AC	30	600	45	35	40	29	1.55	1.35	1.45	1.2	F2		
MUR03006-TO247AD	2*15	600	40	27	35	25	1.55	1.35	1.45	1.2	F5		
MU03006-TO220FH	30	600	45	35	40	29	1.55	1.35	1.45	1.2	F3		
MU04006-TO247AD	40	600	70	50	40	32	1.55	1.3	1.45	1.2	F5		
MU04006-TO247AC	40	600	70	50	40	32	1.55	1.3	1.45	1.2	F6		
MU06006-TO247AD	60	600	60	45	40	32	1.9	1.45	1.8	1.3	F5		
MU06006-TO247AC	60	600	60	45	40	32	1.9	1.45	1.8	1.3	F6		
MUR06006-TO3PB	2*30	600	45	35	40	29	1.55	1.35	1.45	1.2	F7		
MUR06006-TO247AD	2*30	600	45	35	40	29	1.55	1.35	1.45	1.2	F5		
MU08006-TO247AD	80	600	70	56	50	38	1.45	1.25	1.35	1.15	F5		
MUR08006-TO3PB	2*40	600	70	50	40	32	1.55	1.3	1.45	1.2	F7		
MU08006-TO3PB	80	600	70	56	50	38	1.45	1.25	1.35	1.15	F7		
MU08006-TO247AC	80	600	70	56	50	38	1.45	1.25	1.35	1.15	F6		
MU00812-TO220AC	8	1200	45	32	40	28	3.3	2.8	2.8	2.1	F2		
MU01512-TO247AC	15	1200	50	35	45	31	2.4	2	2.2	1.7	F6		
MU01512-TO220AC	15	1200	50	35	45	31	2.4	2	2.2	1.7	F2		
MU01612-TO247AC	16	1200	50	35	45	31	2.4	2	2.2	1.7	F6		
MU01612-TO220AC	16	1200	50	35	45	31	2.4	2	2.2	1.7	F2		
MU03012-TO247AD	30	1200	60	44	50	35	2.4	2	2.2	1.7	F5		
MU03012-TO220AB	30	1200	35	44	50	35	2.4	2	2.2	1.7	F1		
MU03012-TO247AC	30	1200	35	44	50	35	2.4	2	2.2	1.7	F6		
MU03012-TO220AC	30	1200	35	44	50	35	2.4	2	2.2	1.7	F2		
MUR03012-TO247AD	2*15	1200	50	35	45	31	2.4	2	2.2	1.7	F5		
MU06012-TO247AD	60	1200	70	54	55	40	2.4	2	2.2	1.7	F5		
MU06012-TO247AC	60	1200	70	54	55	40	2.4	2	2.2	1.7	F6		
MUR06012-TO247AD	2*30	1200	35	44	50	35	2.4	2	2.2	1.7	F5		

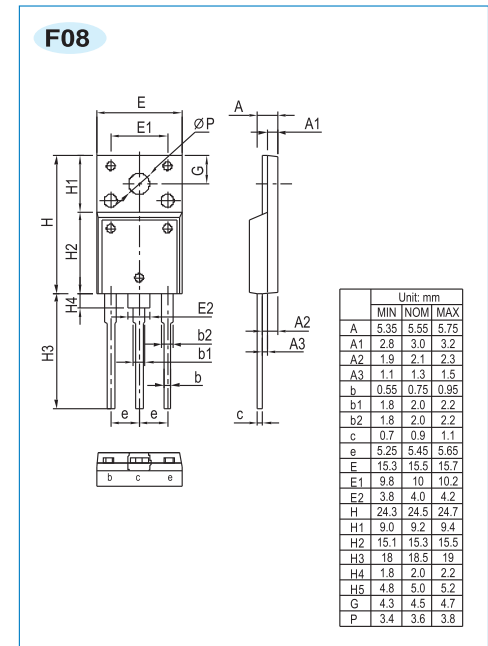
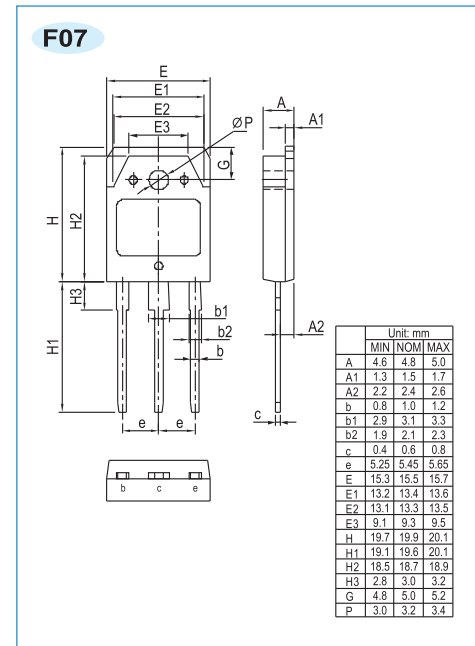
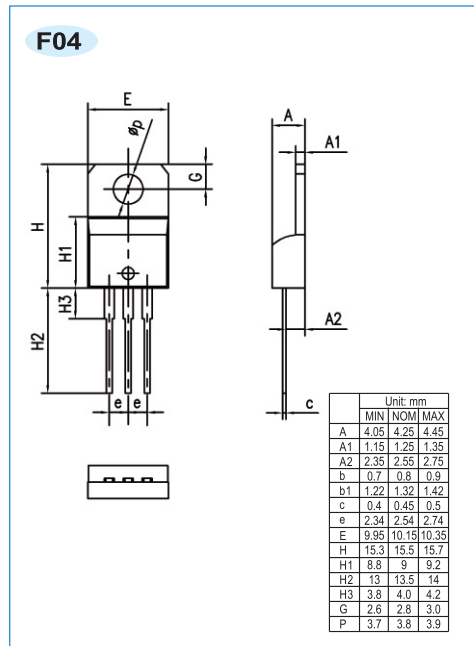
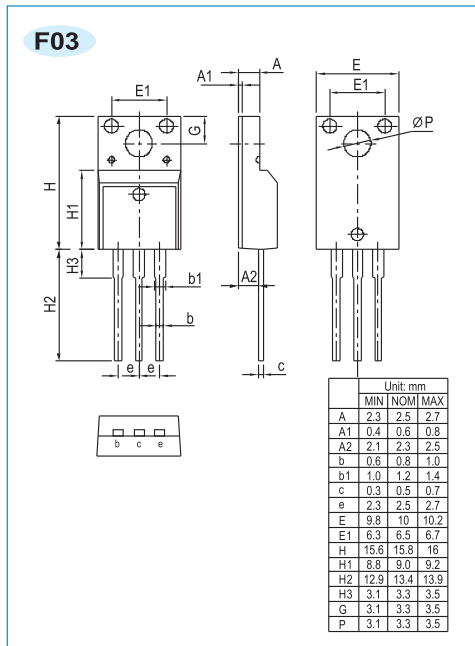
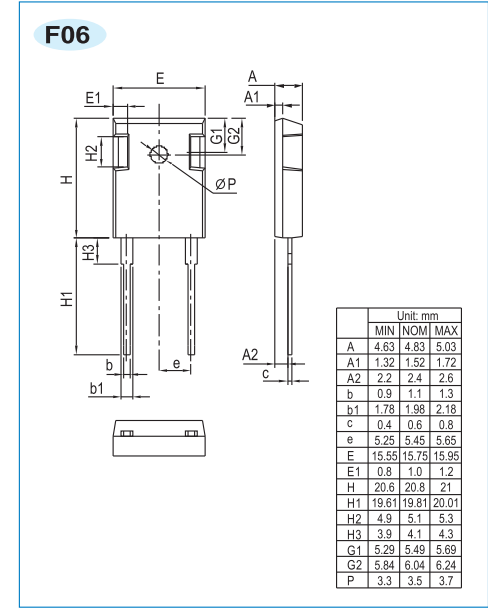
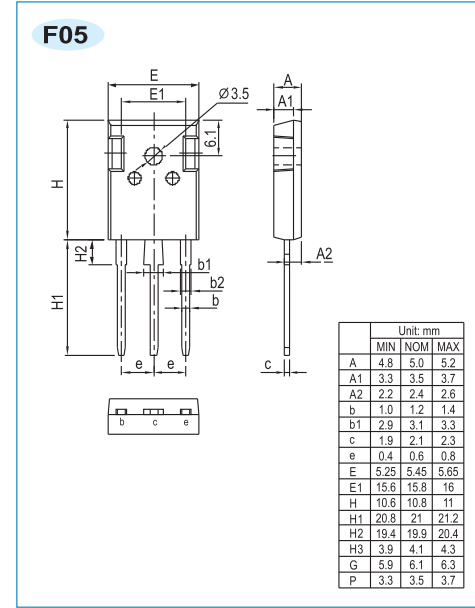
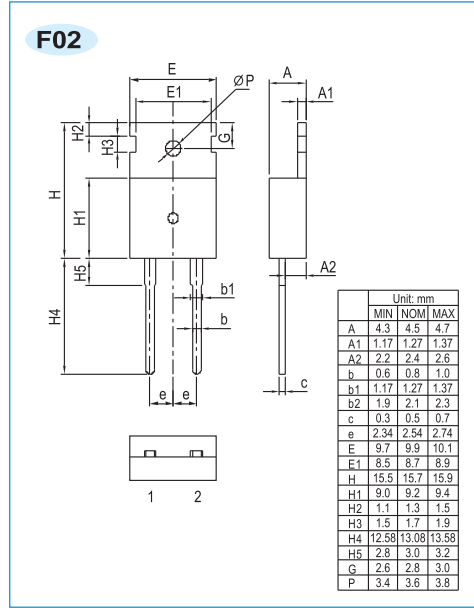
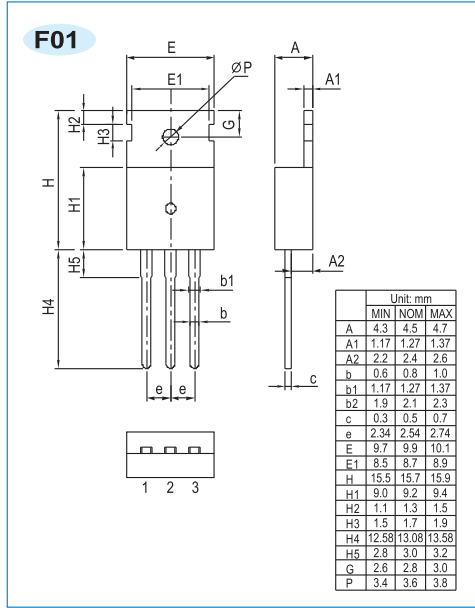

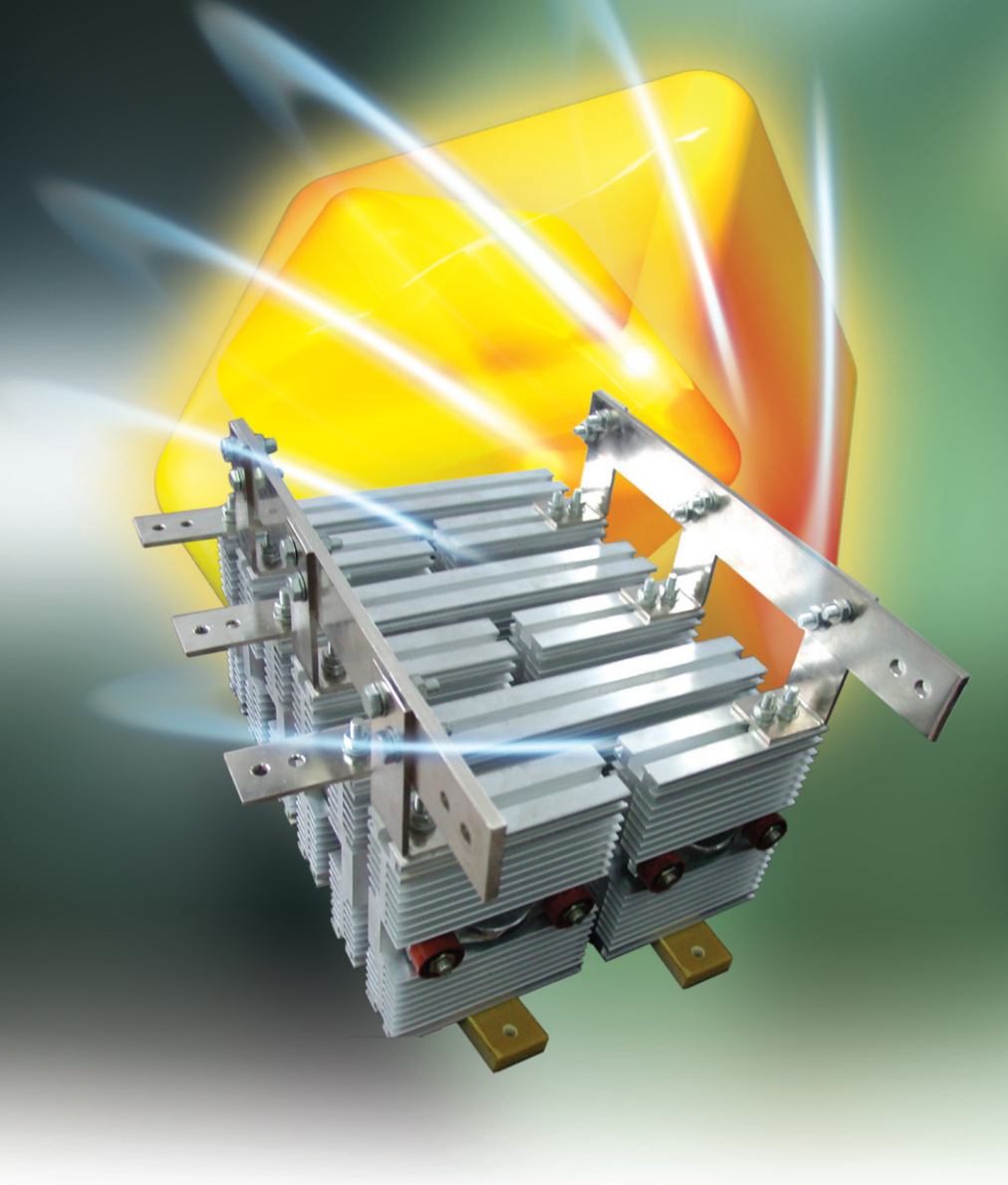

Power Semiconductor Assemblies

Code for circuit connection

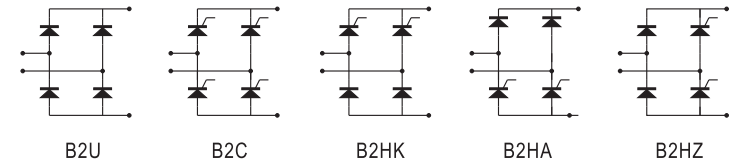

single-phase full-control bridge B2C series, single-phase half-control bridge B2Hx series, single-phase rectification bridge B2U series

Cooling method	Device type	Type $-I_a-V_{VN}$	Rated output current $I_a(A)$	Outline	Cooling condition	Device voltage (V)
Air cooling	Modules	B2x-xxx-xxxFA	40~160	A.1a	Wind speed $\geq 6m/s$ Ambient temperature $\leq 40^\circ C$	100~2000
		B2x-xxx-xxxFB	180~200	A.1b		
		B2x-xxx-xxxFC	250~400	A.3		
	Capsule type devices	B2x-xxx-xxxFD	300~800	A.9b		
		B2x-xxx-xxxFE	800~1200	A.10b		
		B2x-xxx-xxxFF	1200~2000	A.13b		
Water cooling	Capsule type devices	B2x-xxx-xxxSA(B/C/D/E)	100~2500	A.15-19	Flow $\geq 4L/min$ Intake Water temperature $\leq 40^\circ C$	

Code for circuit connection

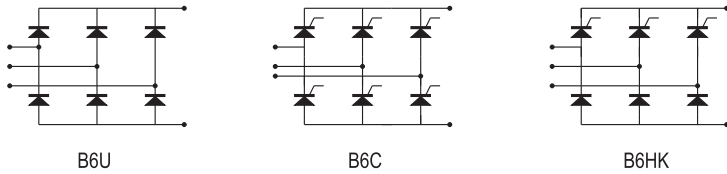

Three-phase rectification bridge B6U series, three-phase full-control bridge B6C series, three-phase half-control bridge B6HK series

Cooling method	Device type	Type -I _o -V _{VN}	Rated output current I _o (A)	Outline	Cooling condition	Device voltage (V)
Air cooling	Modules	B6x-xxx-xxxFA	80~200	*A.1a	Wind speed ≥6m/s Ambient temperature ≤ 40°C	100~2000
		B6x-xxx-xxxFB	200~300	*A.1b		
		B6x-xxx-xxxFC	300~500	*A.3		
	Capsule type devices	B6x-xxx-xxxFD	400~1600	A.9a		
		B6x-xxx-xxxFE	1000~2000	A.10a		
		B6x-xxx-xxxFF	1500~3000	A.13a		
Water cooling	Capsule type devices	B6x-xxx-xxxSA(B/C/D/E)	300~4000	A.15-19	Flow ≥4L/ in Intake Water temperature ≤ 40°C	

* Busbar should be connected outer

Code for circuit connection

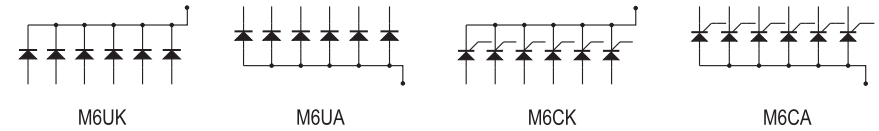

Six-phase bridge M6x series

Cooling method	Device type	Type -I _o -V _{VN}	Rated output current I _o (A)		Outline	Cooling condition	Device voltage (V)
			double-star type with balance reactor	double-star type without balance reactor			
Air cooling	Modules	M6x-xxx-xxxFA	150~350	130~300		Wind speed ≥6m/s Ambient temperature ≤ 40°C	100~2000
		M6x-xxx-xxxFB	450~600	350~500			
		M6x-xxx-xxxFC	800~1200	600~800			
	Capsule type devices	M6x-xxx-xxxFD	1500~2500	1200~2000			
		M6x-xxx-xxxFE	3000~4000	2500~3400			
		M6x-xxx-xxxFF	5000~6000	4000~5000			
		M6x-xxx-xxxFG	1500~1800	1000~1500			
Water cooling	Capsule type devices	*M6x-xxx-xxxSA(B/C/D/E)	500~8000	400~5000		Flow ≥4L/ in Intake Water temperature ≤ 40°C	

* Busbar should be connected outer

Code for circuit connection

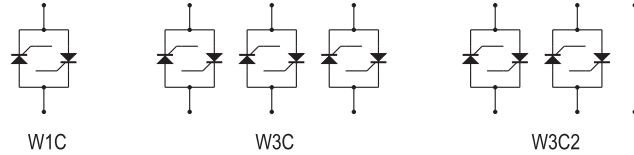

Code for circuit connection

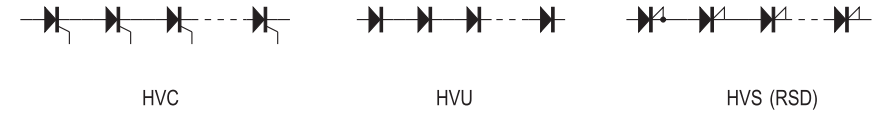

Single-phase AC switch, W1C series

Cooling method	Device type	Type -I _{RMS} -V _{VN}	Rated output current I _{RMS} (A)	Outline	Cooling condition	Device voltage (V)
Air cooling	Modules	W1C-xxx-xxxFA	90~150	A.2a	Wind speed ≥6m/s Ambient temperature ≤40°C	100~2000
		W1C-xxx-xxxFB	200~250	A.2b		
		W1C-xxx-xxxFC	300	A.4		
	Capsule type devices	W1C-xxx-xxxFD	400~800	A.5		
		W1C-xxx-xxxFE	1000~1200	A.6		
		W1C-xxx-xxxFF	1500~1800	A.11		
Water cooling	Capsule type devices	W1C-xxx-xxxSA(B/C/D/E)	600~2500	A.15-19	Flow ≥4L/min Intake Water temperature ≤40°C	
		W1C-xxx-xxxSI(J/K)	800~1200	A.20-22		

Three-phase AC switch, W3C series

Cooling method	Device type	Type -I _{RMS} -V _{VN}	Rated output current I _{RMS} (A)	Outline	Cooling condition	Device voltage (V)
Air cooling	Modules	W3C-xxx-xxxFA	90~150	A.2a	Wind speed ≥6m/s Ambient temperature ≤40°C	100~2000
		W3C-xxx-xxxFB	200~250	A.2b		
		W3C-xxx-xxxFC	300	A.4		
	Capsule type devices	W3C-xxx-xxxFD	400~800	A.7		
		W3C-xxx-xxxFE	1000~1200	A.8		
		W3C-xxx-xxxFF	1500~1800	A.12		

TECHSEM provides various of thyristors/diodes/RSD high voltage assemblies to meet customers requirements. TECHSEM provides various power assemblies of high voltage, large power and assemblies with super high di/dt in pulse power field.

Cooling method	Type -I _a -V _{VN}	Device voltage (V)	* Rated output current (A)	Outline
Air cooling	HVx-xxx-xxxFx	3000~30000	50~500	

* The rated current of power assembly depends on working condition.

A.1a,b

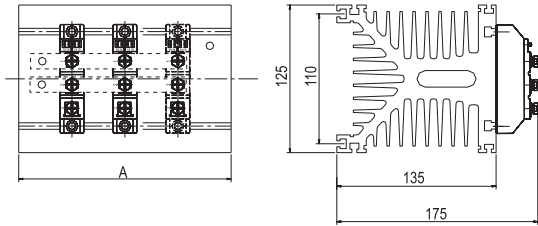

	Fig.1a	Fig.1b
A	180	260

A.2a,b

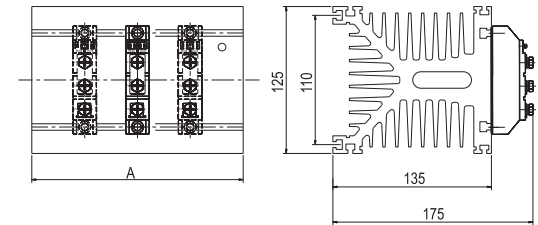
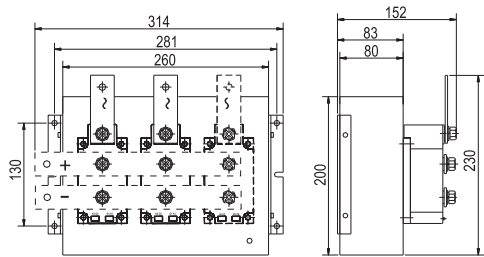
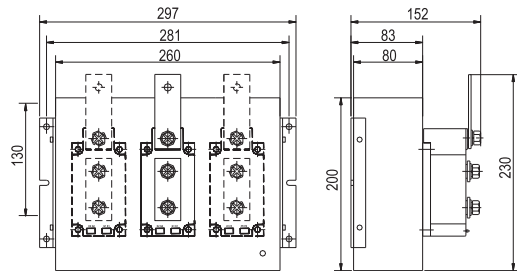

	Fig.2a	Fig.2b
A	180	260

A.3



A.4



A.5

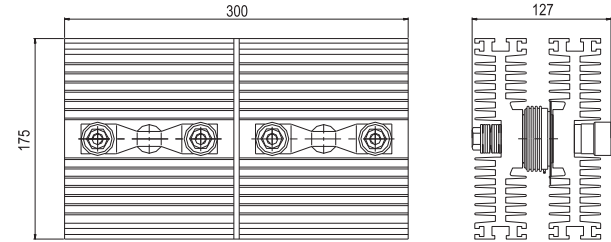

A.6

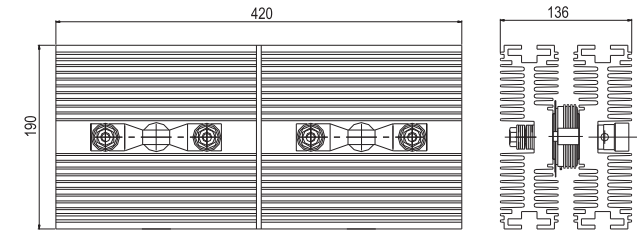

A.7

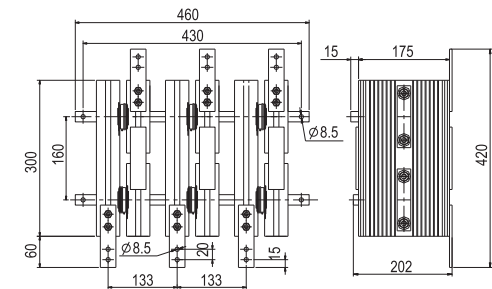

A.8

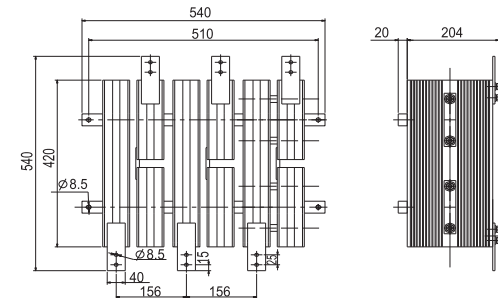

A.9a,b

	A	B	C
Fig.9a	500	460	430
Fig.9b	370	330	300

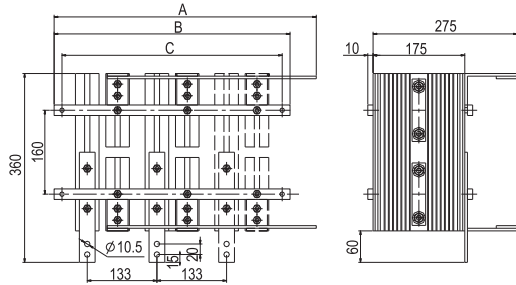

A.10a,b

	A	B	C
Fig.10a	552	540	510
Fig.10b	395	384	354

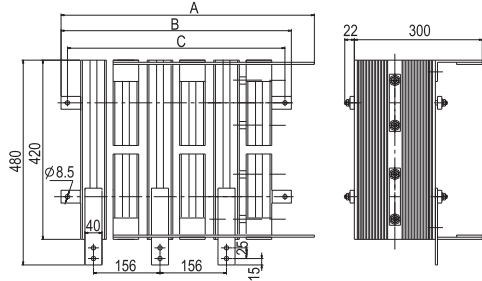

A.11

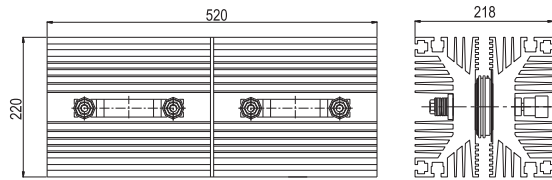

A.12

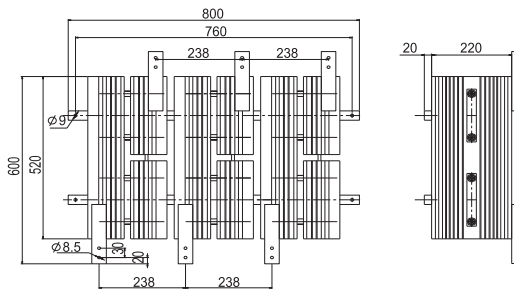

A.13a,b

	A	B	C
Fig.13a	850	800	760
Fig.13b	613	563	523

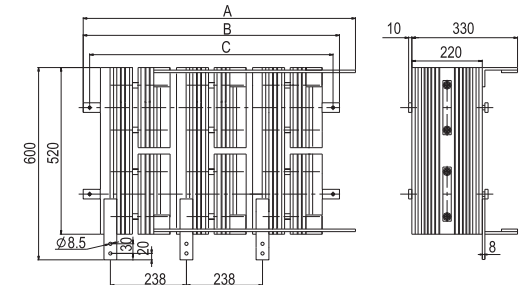

A.14

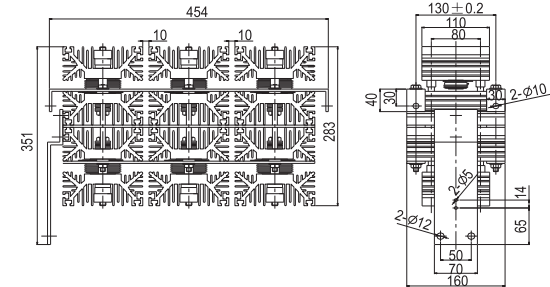

A.23

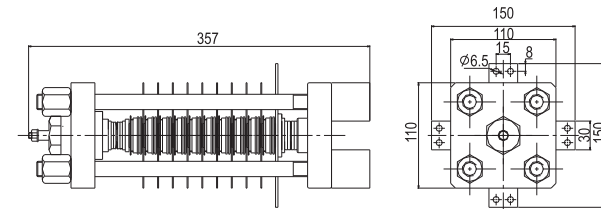



Heatsinks

Features

- Thermal design is suitable for different application environment
- Air cooling, water cooling
- Customized solution

Water Cooling

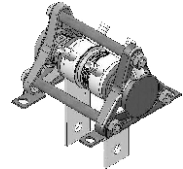
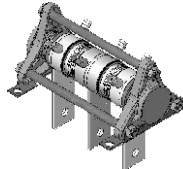
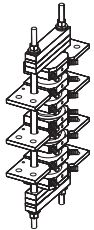
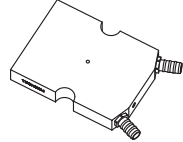
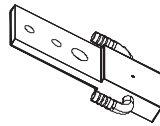
Type	Shape	Outline
SS11		S.1
SS12		S.3
SS13		S.5
SS14		S.7
SS15		S.2
SS16		S.4
SS11BL		S.6
SS12BL		S.11
SS13BL		S.12
SS14BL		S.13
SS15BL		S.15
RSS11		S.16
RSS21		S.15
RSS31		S.16
RSS51		S.15
RSS		S.16

Size details, please refer to TECHSEM official website: www.tech-sem.com

SF series Forced air cooling for Type devices

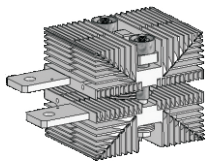
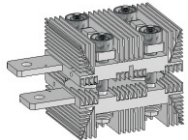
SF12		S.22
SF13		S.23
SF14		
SF15		
SF16		
SF17		S.24
SF12BL		S.25
SF15BL		

Size details, please refer to TECHSEM official website: www.tech-sem.com

Forced Air Cooling for Power Modules

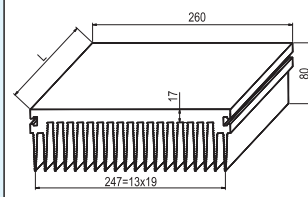
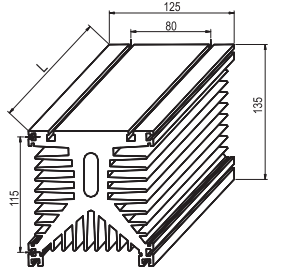
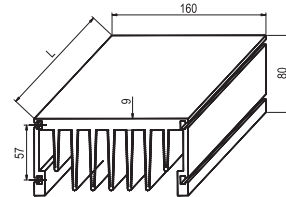
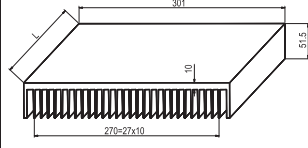
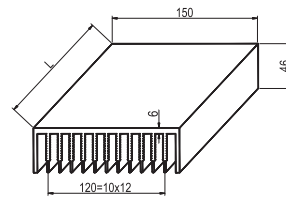
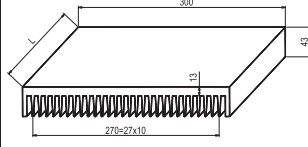
Type	Shape	Type	Shape
D		N	
Z		H	
W		K	

Size details, please refer to TECHSEM official website: www.tech-sem.com

Forced Air Cooling For Capsule Type Devices

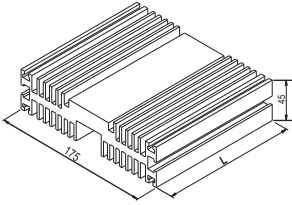
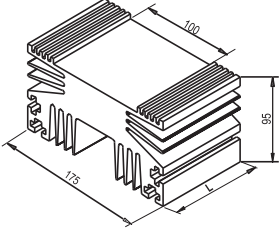
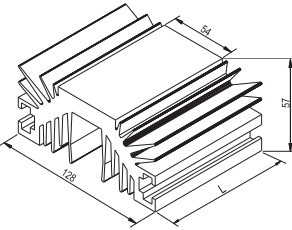
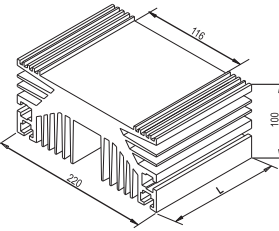
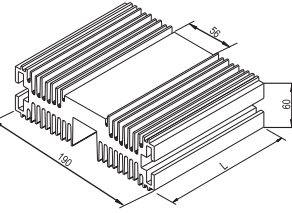
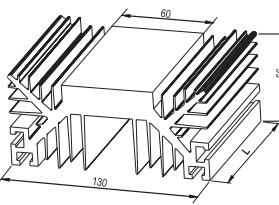
Type	Shape	Type	Shape
FD		FI	
FK		FF	
FE		FG	

Size details, please refer to TECHSEM official website: www.tech-sem.com

Forced Air Cooling For Capsule Type Devices

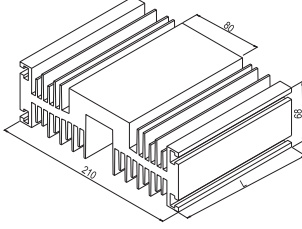
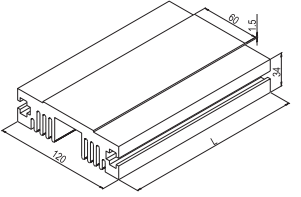
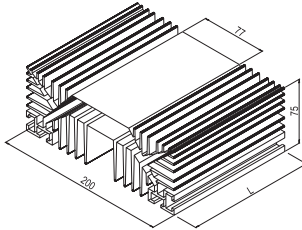
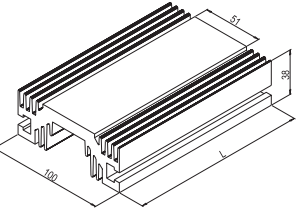
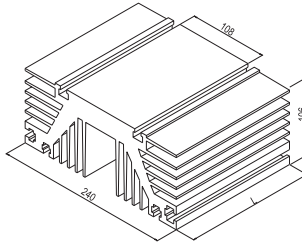
Type	Shape	Type	Shape
FAI		FAJ	
FAE		FAK	
FAD			

Size details, please refer to TECHSEM official website: www.tech-sem.com

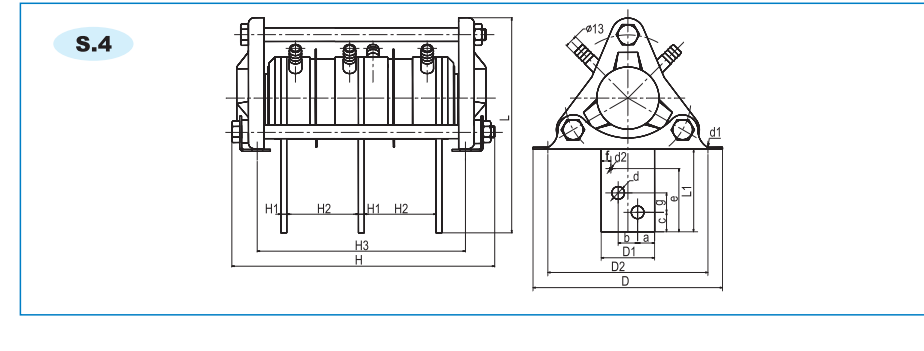
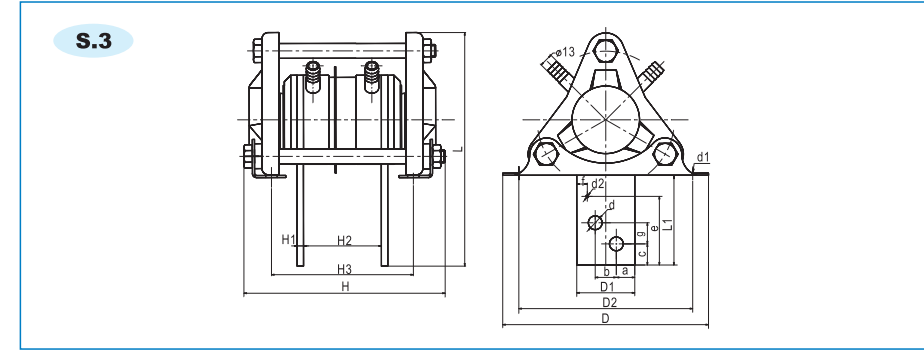
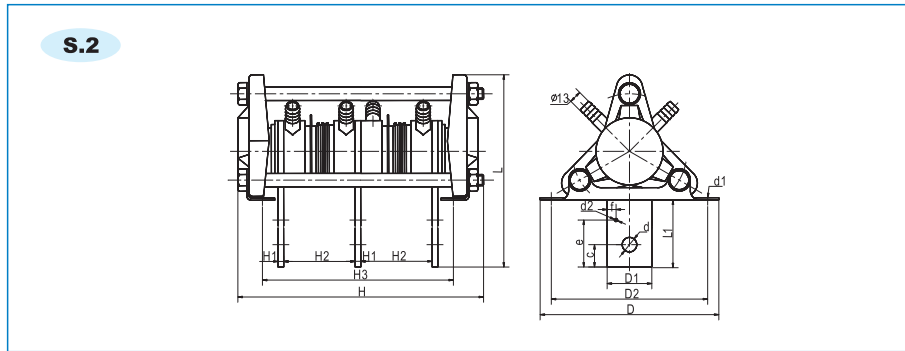
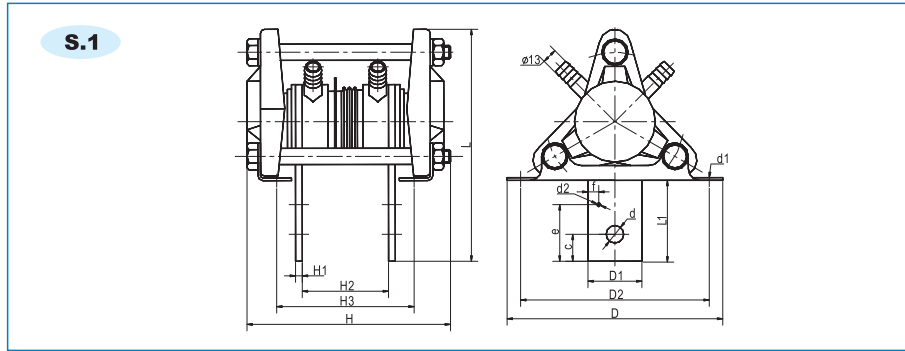

Type	Outline dimension			Busbar dimension			Mounting dimension								
	L	D	H	L1	H1	D1	D2	H2	H3	d	d1	d2	c	e	f
SS11	140	135	145	53	4	30	112	64	105	2-φ9	9×14	M3	20	35	6
SS12	190	160	152	78	5	40	140	64	105	2-φ13	11×14	M3	20	65	8
SS11BL	140	135	215	53	4	30	112	64	173	3-φ9	9×14	M3	20	35	6
SS12BL	190	160	220	78	5	40	140	64	174	3-φ13	11×14	M3	20	65	8

Type	SS11、SS11BL	SS12、SS12BL
Mesa diameter	Φ45 Φ23 Φ27	Φ55 Φ31 Φ36 Φ41
Suitable case	Φ19~Φ40	Φ34~Φ40
	Φ24 Φ28	Φ32 Φ37 Φ42
Mounting Force P(kN)	3.3~20	5.5~25
Thermal resistance (°C/W)	0.026	0.018
Applicable range	Suitable for device of 200~800A Water flow ≥4L/Min	

Type	Outline dimension			Busbar dimension			Mounting dimension											
	L	D	H	L1	H1	D1	D2	H2	H3	d	d1	d2	a	b	c	e	f	g
SS13	190	160	158	78	6	50	140	64	105	4-φ13	11x14	M3	15	20	15	65	8	20
SS14	220	195	188	85	6	55	165	74	130	4-φ13	11x14	M3	17.5	20	20	65	10	20
SS13BL	190	160	220	78	6	50	140	64	172	6-φ13	11x13	M3	15	20	15	65	8	20
SS14BL	220	195	268	85	6	55	165	74	210	6-φ13	11x13	M3	17.5	20	20	65	10	20

Type	Mesa diameter	Suitable case	Mounting Force P(kN)	Weight (kg)	Thermal resistance (°C/W)
SS13、SS13BL	Φ68	Φ40~Φ55	15~34	≥1.7	0.015
SS14、SS14BL	Φ84	Φ50~Φ73	18~47	≥2.2	0.013
Applicable range	Suitable for device of 500~2000A Water flow ≥6L/Min		1500~2000A Water flow ≥7L/Min		

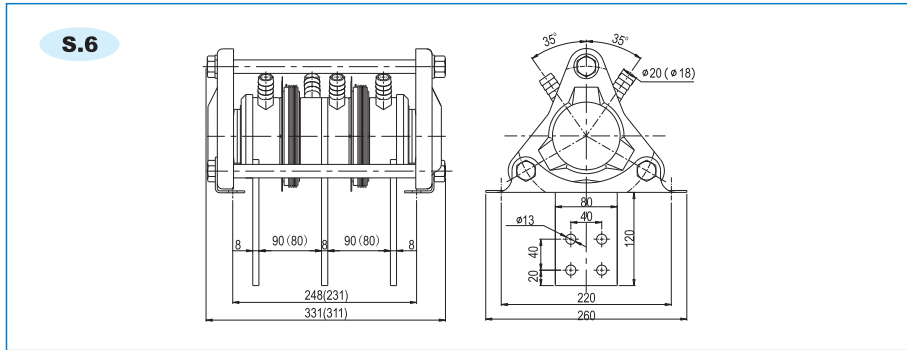
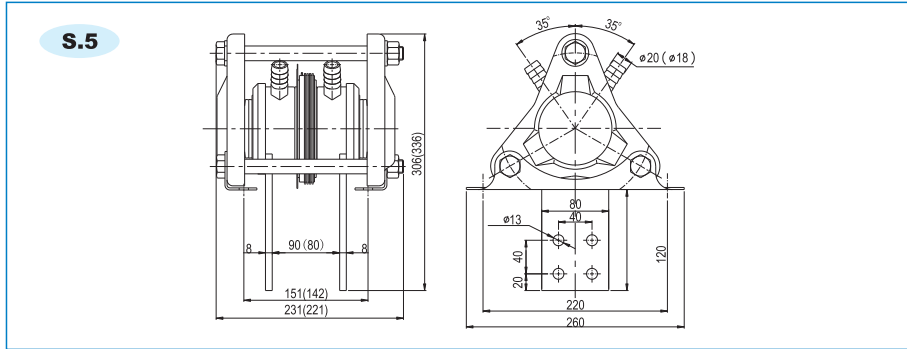

Type	Mesa diameter	Suitable case	Mounting Force P(kN)	Thermal resistance (°C/W)
SS15, SS15BL	Φ100	Φ73~Φ100	60 ~100	0.011
Applicable range	Suitable for device of 2000~3000A Water flow ≥8L/Min			

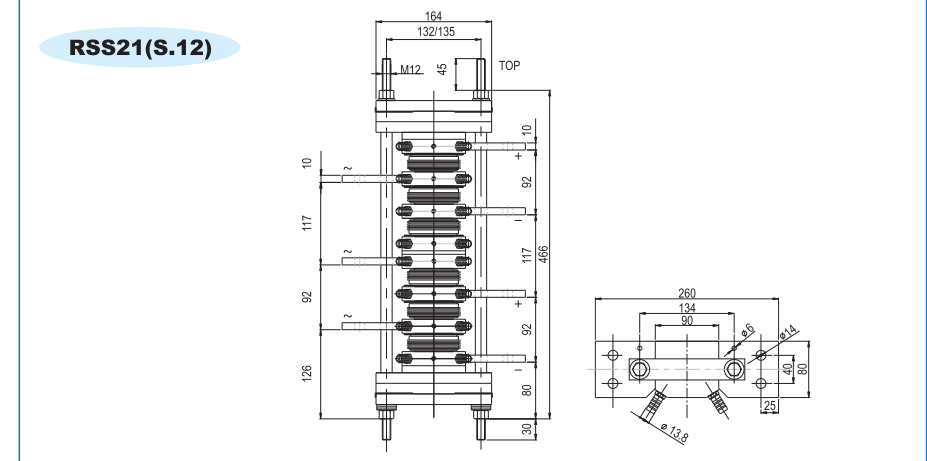
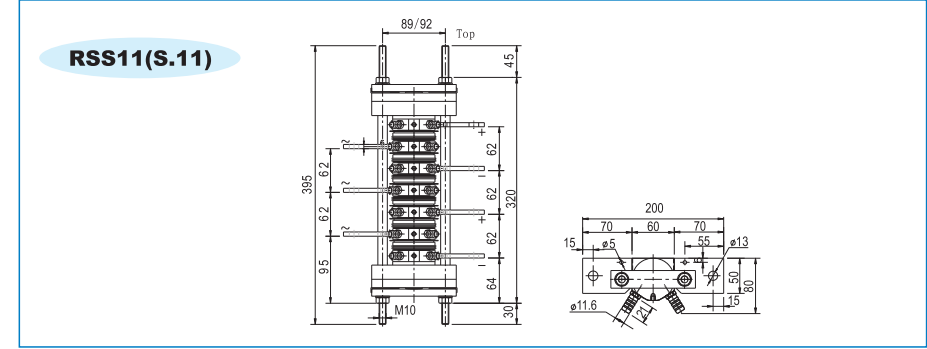

Type	Mesa diameter	Suitable case	Mounting Force P(kN)	Thermal resistance (°C/W)	Applicable range	Outline
RSS11	Φ50	Φ25~Φ50	10 ~ 26	0.018	Suitable for device of 200-1200A Water flow ≥4L/Min	S.11
RSS21	Φ80	Φ50~Φ80	26 ~ 47	0.013	Suitable for device of 500-3000A Water flow ≥6L/Min	S.12
RSS31	Φ70	Φ40~Φ70	15 ~ 34	0.015	Suitable for device of 500-2500A Water flow ≥6L/Min	S.13
RSS41	Φ90	Φ60~Φ84	30 ~ 85	0.01	Suitable for device of 1000-4000A Water flow ≥7L/Min	S.14
RSS51	Φ80	Φ50~Φ80	26 ~ 47	0.012	Suitable for device of 1000-3500A Water flow ≥8L/Min	S.15
RSS61	Φ126	Φ90~Φ120	70 ~ 120	0.007	Suitable for device of 2000-5000A Water flow ≥8L/Min	S.16

SF12, SF13(S.22)

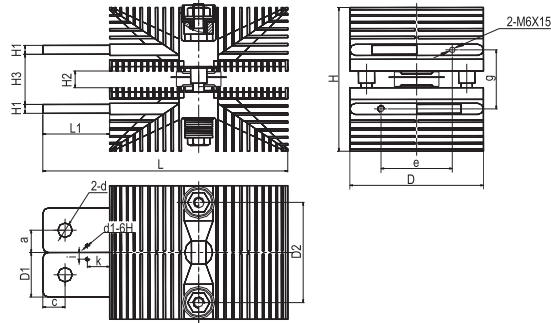

SF14, SF15, SF16, SF17 (S.23)

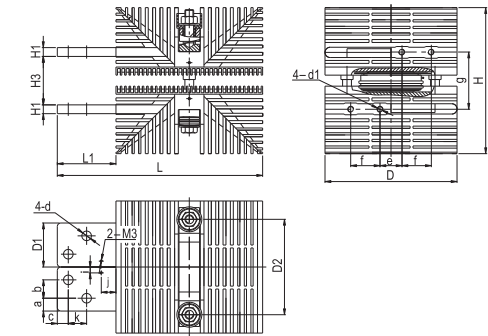

FORCED AIR COOLING

Type	Outline dimension			Busbar dimension				Moutline dimension										
	L	D	H	L1	D1	H1	D2	H2	H3	d	d1	a	c	e	g	i	k	
SF12	200	110	125	60	40	8	80	15	22	φ13	M3	20	20	55	30	6	20	
SF13	220	120	130	60	40	8	90	15	45	φ13	M3	20	20	64	53	6	20	

Type	Outline dimension			Busbar dimension			Moutline dimension													
	L	D	H	L1	D1	H1	D2	H2	H3	d	d1	a	b	c	e	f	g	i	j	k
SF14	250	140	145	80	50	10	105	15	45	φ11	M6	12.5	25	12.5	40	35	55	8	20	25
SF15	280	140	165	80	60	12	105	15	50	φ13	M8	17.5	25	15	40	35	62	8	20	25
SF16	280	180	200	80	60	12	130	15	66	φ13	M8	17.5	25	15	30	40	78	8	20	25
SF17	300	200	215	80	60	12	140	15	73	φ13	M8	17.5	25	15	40	40	85	8	24	25

Type	SF12			SF13		
Mesa diameter	Φ65	Φ23	Φ27	Φ65	Φ27	Φ31
Suitable case	Φ19~Φ40			Φ34~Φ40		
	Φ24	Φ28		Φ28	Φ32	
Mounting force P(kN)	3.3~20			5.5~25		
Thermal resistance (°C/W)	0.090			0.071		
Applicable range	Suitable for device of 200~800A Wind speed ≥4m/s					

Type	SF14			SF15			SF16	SF17	
Mesa diameter	Φ82	Φ31	Φ36	Φ82	Φ31	Φ36	Φ41	Φ82	Φ120
Suitable case	Φ34~Φ45			Φ40~Φ47			Φ45~Φ65	Φ40~Φ73	
	Φ32	Φ37		Φ32	Φ37	Φ42	—	—	
Mounting Force P(kN)	5.5~30			10~34			15~40	15~47	
Thermal resistance (°C/W)	0.056			0.048			0.037	0.030	
Applicable range	Suitable for device of 600~2000A Wind speed ≥4m/s for over 1500A Wind speed ≥6m/s								

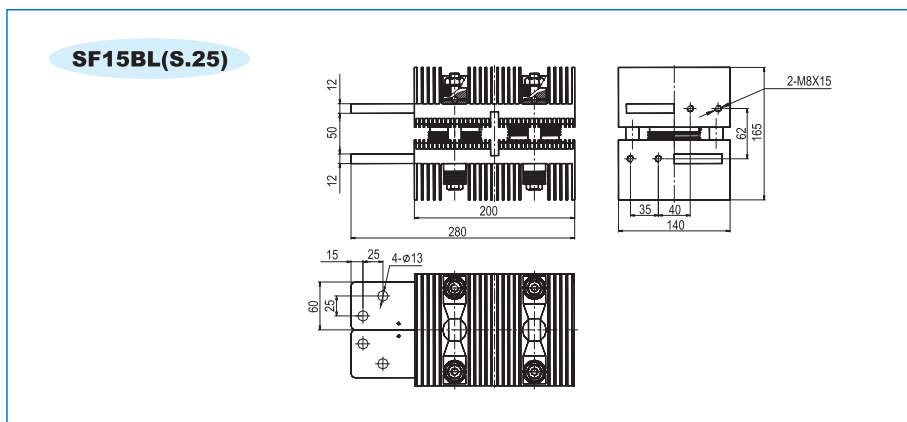
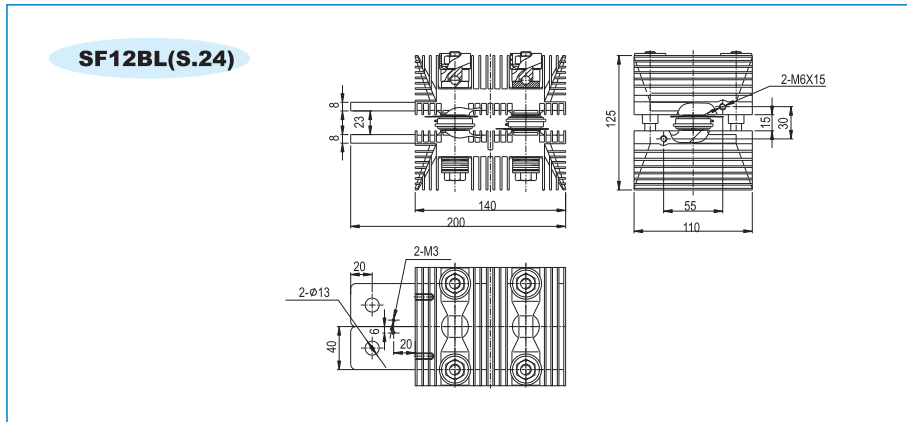

Type	Mesa diameter	Suitable case	Mounting Force P(kN)	Thermal resistance (°C/W)	Applicable range
SF12BL	Φ27	Φ19~Φ25	3.3 ~ 20	0.050	Suitable for device of 200A Wind speed ≥4m/s Assembly for anti-parallel connection
SF15BL	Φ82	Φ34~Φ45	10 ~ 34	0.090	Suitable for device of 300~ 500A Wind speed ≥4m/s Assembly for anti-parallel connection

Letter Symbols and Terms

Symbols	Characteristic
di/dt	Critical rate of rise of on-state current
dv/dt	Critical rate of rise of off-state voltage
I^2t	I^2t value
I_d	Direct output current (of a rectifier connection)
I_{DRM}	Repetitive peak off-state current
$I_{F(AV)}$	Mean forward current
I_{FM}	Peak forward current
$I_{F(RMS)}$	RMS forward current
I_{FSM}	Surge forward current
I_G	Gate current
I_{GD}	Gate non-trigger current
I_{GT}	Gate trigger current
I_P	Repetitive peak sine pulse current of RSD
I_H	Holding current
I_{RRM}	Repetitive peak reverse current
$I_{T(AV)}$	Mean on-state current
$I_{T(RMS)}$	RMS on-state current
I_{TM}	Peak on-state current
I_{TSM}	Surge on-state current
Q_{rr}	Reverse recovery charge
r_T	On-state slope resistance
r_F	Forward slope resistance
R_{th}	Thermal resistance
$R_{th(c-hs)}$	Contact thermal resistance case to heatsink
$R_{th(h-a)}$	Thermal resistance heatsink to ambient air
$R_{th(j-c)}$	Thermal resistance junction to case

Symbols	Characteristic
$R_{th(j-hs)}$	Thermal resistance junction to heatsink
T_a	Ambient temperature
T_c	Case temperature
T_{HS}	Heatsink temperature
T_j	Junction temperature
T_{jm}	Max. junction temperature
T_{stg}	Storage temperature
t_p	Pulse duration
t_q	Circuit commutated turn-off time
t_{rr}	Reverse recovery time
V_D	Direct output voltage
V_{DRM}	Repetitive peak off-state voltage
V_{DSM}	Non-repetitive peak off-state voltage
V_{FM}	Peak forward voltage
V_{FO}	Forward threshold voltage
V_G	Gate voltage
V_{GT}	Gate trigger voltage
V_{GD}	Gate non-trigger voltage
V_{iso}	Isolation voltage
V_{RRM}	Repetitive peak reverse blocking voltage
V_{TO}	On-state threshold voltage
V_{RSM}	Non-repetitive peak reverse blocking voltage
V_T	On-state voltage
V_{TM}	Peak on-state voltage