



Disea Electronics Co., LTD

An IATF16949 display manufacturing company.
Focus on Industrial &Auto LCD display customized service.

URL:www.diseaelec.com.

E-mail:mkt@diseaelec.com

PRODUCT SPECIFICATIONS

For Customer: _____

: APPROVAL FOR SPECIFICATION

Customer Model No. _____

: APPROVAL FOR SAMPLE

Module No.: ZW-T121KZH-01

 Date : 2022-11-17

Table of Contents

No.	Item	Page
1	Cover Sheet(Table of Contents)	P1
2	Revision Record	P2
3	General Specifications	P3
4	Outline Drawing	P4
5	Absolute Maximum Ratings	P5
6	Electrical Specifications	P6-P11
7	Optical Characteristics	P12-P15
8	Reliability Test Items and Criteria	P16
9	Precautions for Use of LCD Modules	P17-P18

For Customer's Acceptance:

Approved By	Comment

PREPARED	CHECKED	VERIFIED BY QA DEPT	VERIFIED BY R&D DEPT
SSX			

3. General Specifications

ZW-T123KZH-01 is a TFT-LCD module. It is composed of a TFT-LCD panel, driver IC, FPC, a back light unit. The 12.3'' display area contains 1920x(RGB)x720 pixels and can display up to 16.7M colors. This product accords with RoHS environmental criterion.

Item	Contents	Unit	Note
LCD Type	TFT	-	
Display color	16.7M	-	1
Viewing Direction	ALL	O'Clock	
Operating temperature	-30~+85	°C	
Storage temperature	-40~+90	°C	
Module size	302.53 x 123.57 x 6.51	mm	2
Active Area(W×H)	292.03(W) x 109.51(H)	mm	
Number of Dots	1920 x 720	dots	
Controller	TBD	-	
Power Supply Voltage	3.3	V	
Backlight	9S4P-LEDs (white)	pcs	
Weight	---	g	
Interface	LVDS	-	

Note 1: Color tune is slightly changed by temperature and driving voltage.

Note 2: Without FPC and Solder.

4. Outline Drawing

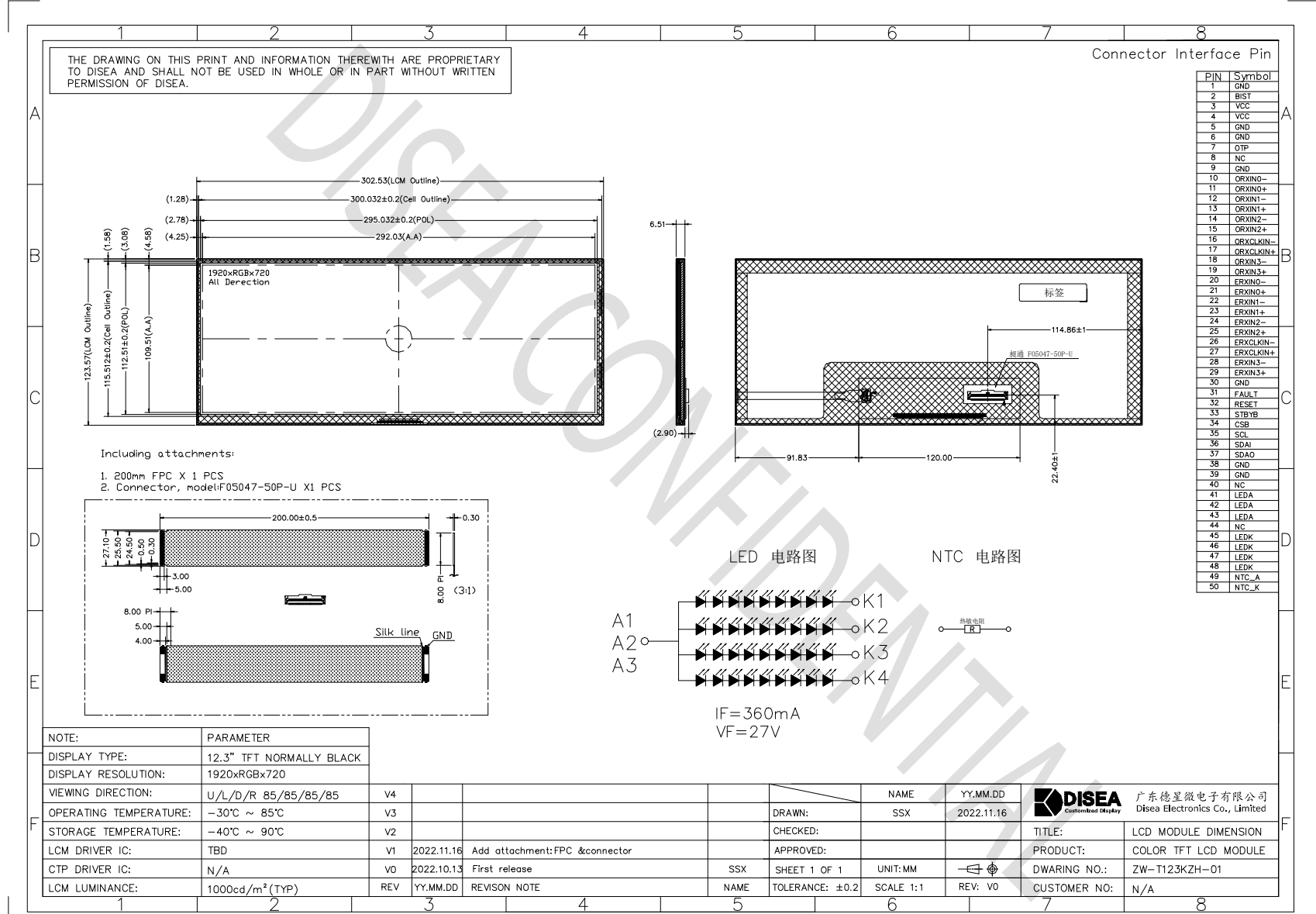

5. Absolute Maximum Ratings(Ta=25°C)

5.1 Electrical Absolute Maximum Ratings.(Vss=0V ,Ta=25°C)

Item	Symbol	Min.	Max.	Unit	Note
Power Supply Voltage	V _{DD}	-0.3	4.0	V	1, 2
Logic Supply Voltage	V _{IN}	-0.3	V _{DD} +0.3	V	1, 2

Notes:

1. If the module is above these absolute maximum ratings. It may become permanently damaged. Using the module within the following electrical characteristic conditions are also exceeded, the module will malfunction and cause poor reliability.
2. V_{CC} > V_{SS} must be maintained.

5.2 Environmental Absolute Maximum Ratings.

Item	Storage		Operating		Note
	MIN.	MAX.	MIN.	MAX.	
Ambient Temperature	-40°C	90°C	-30°C	85°C	1,2
Humidity	-	-	-	-	3

1. The response time will become lower when operated at low temperature.
2. Background color changes slightly depending on ambient temperature.
The phenomenon is reversible.
3. Ta ≤ 40°C : 85%RH MAX.

Ta > 40°C : Absolute humidity must be lower than the humidity of 85%RH at 40°C.

6. Electrical Specifications and Instruction Code

6.1 Electrical characteristics(V_{SS}=0V ,T_a=25°C)

Parameter	Symbol	Min.	Typ.	Max.	Unit	Remarks
Power Supply Voltage	VDD	-	3.3	-	V	2
Permissible Input Ripple Voltage	VRF	-	-	220	mV	-
Power Supply Current IDD	IDD	-	-	TBD	mA	1
Power Supply Inrush Current	Inrush	-	-	1.5	A	2
Power Consumption	Mosaic	-	-	TBD	W	1

Notes

1. The supply voltage is measured and specified at the interface connector of LCM. The current draw and power consumption specified is for 3.3V at 25 °C.

Mosaic 7*5 pattern

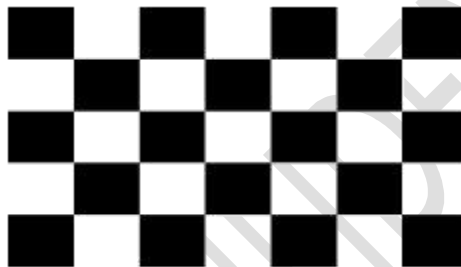

Power Measure Patterns

2. Measure condition

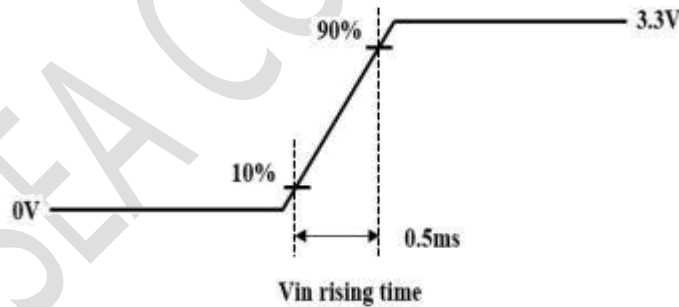

Inrush Measure Condition

6.2 LED backlight specification(VSS=0V ,Ta=25°C)

Item	Symbol	Condition	Min	Typ	Max	Unit	Note
Supply voltage	V_f	If=360mA	24.3	27.0	30.6	V	
Uniformity	ΔB_p	If=360mA	-	75	-	%	
Life Time	time	If=360mA	30K	-	-	hours	1

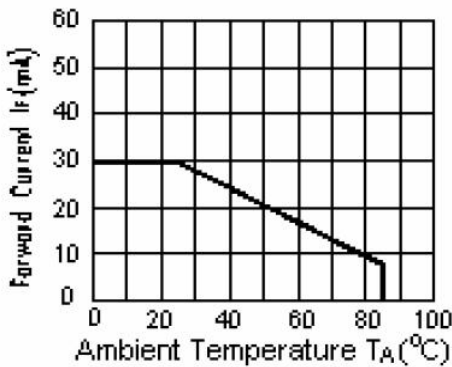

Note 1: Brightness to be decreased to 50% of the initial value at ambient temperature $T_A=25^\circ\text{C}$

NTC information :

ITEM	Value	Remark
Part number	NCU15XH103F6SRC	Murata
Resistance / Tolerance	10kΩ+/- 1%	$T_a = 25^\circ\text{C}$
Permissive Operating Current (Max.)	0.31 mA	

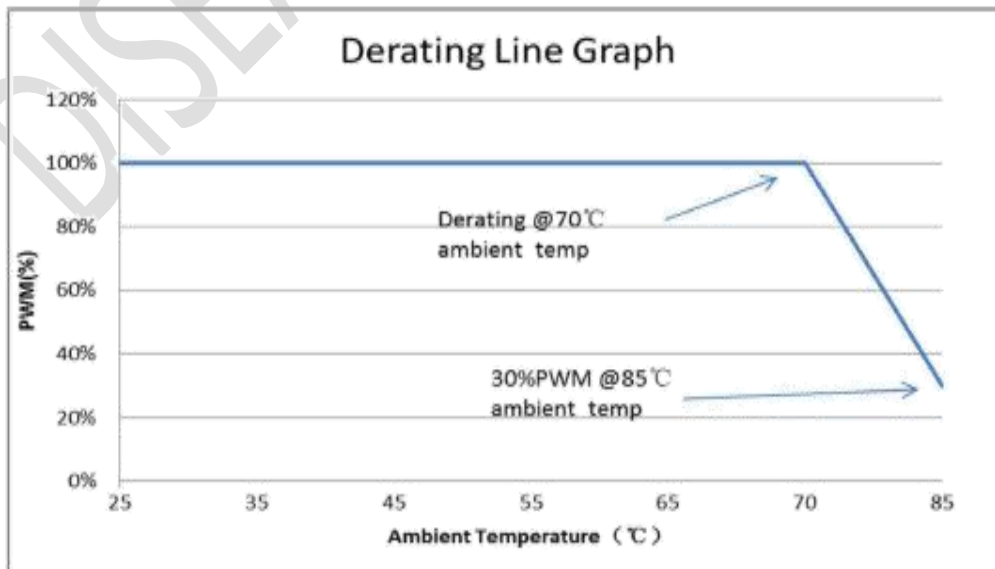

6.3 Interface signals

The electronics interface connector is 昶通 F05047-50P-U

NO.	Symbol	Functions
1	GND	Digital ground
2	BIST	LCD Panel Self Test Enable, When it is not used, connecting to GND is recommended, don't floating.
3	VCC	Digital Power/Vin = 3.3V
4	VCC	Digital Power/Vin = 3.3V
5	GND	Digital ground
6	GND	Digital ground
7	OTP	Serial interface OTP power
8	NC	No connector
9	GND	Digital ground
10	ORXIN0-	Negative LVDS differential data input(Odd data)
11	ORXIN0+	Positive LVDS differential data input(Odd data)
12	ORXIN1-	Negative LVDS differential data input(Odd data)
13	ORXIN1+	Positive LVDS differential data input(Odd data)
14	ORXIN2-	Negative LVDS differential data input(Odd data)
15	ORXIN2+	Positive LVDS differential data input(Odd data)
16	ORXCLKIN-	Negative LVDS differential data input(Odd clock)
17	ORXCLKIN+	Positive LVDS differential data input(Odd clock)
18	ORXIN3-	Negative LVDS differential data input(Odd data)
19	ORXIN3+	Positive LVDS differential data input(Odd data)
20	ERXIN0-	Negative LVDS differential data input(Even data)
21	ERXIN0+	Positive LVDS differential data input(Even data)
22	ERXIN1-	Negative LVDS differential data input(Even data)
23	ERXIN1+	Positive LVDS differential data input(Even data)
24	ERXIN2-	Negative LVDS differential data input(Even data)
25	ERXIN2+	Positive LVDS differential data input(Even data)
26	ERXCLKIN-	Negative LVDS differential data input(Even clock)
27	ERXCLKIN+	Positive LVDS differential data input(Even clock)
28	ERXIN3-	Negative LVDS differential data input(Even data)
29	ERXIN3+	Positive LVDS differential data input(Even data)
30	GND	Digital ground
31	FAULT	FAULT signal output(normal=H, abnormal=L)
32	RESET	Global reset pin, active High
33	STBYB	Standby mode, active High
34	CSB	Serial interface chip enable
35	SCL	Serial interface clock input
36	SDAI	Serial interface data input
37	SDAO	Serial interface data output

38	GND	Digital ground
39	GND	Digital ground
40	NC	No connector
41	LEDA	LED power(Anode)
42	LEDA	LED power(Anode)
43	LEDA	LED power(Anode)
44	NC	No connector
45	LEDK	LED power (Cathode1)
46	LEDK	LED power (Cathode2)
47	LEDK	LED power (Cathode3)
48	LEDK	LED power (Cathode4)
49	NTC_A	NTC_Anode
50	NTC_K	NTC_Cathode

DISEA CONFIDENTIAL

6.4 DC Electrical Characteristics

6.4.1 Signal Timing Specification

Parameter	Symbols	Panel Resolution			Unit
		1920RGB*720 (2 port)			
		Min.	Typ.	Max.	
DCLK frequency	Fdclk	-	45.3	-	MHz
Horizontal valid data	Thd	-	960	-	DCLK
1 horizontal line	Th	1015	1026	1248	DCLK
Vertical valid data	Tvd	-	720	-	H
1 vertical field	Tv	730	736	756	H
Frame rate	FR	-	60	-	Hz

6.4.2 Signal Electrical Characteristics for LVDS Receiver

The built-in LVDS receiver is compatible with (ANSI/TIA/TIA-644) standard.

Parameter	Symbols	Condition	Specification			Unit
			Min.	Typ.	Max.	
Differential input high Threshold voltage	V _{th}	V _{cm} =1.2V	0.1	-	-	
Differential input low Threshold voltage	V _{tl}	V _{cm} =1.2V	-	-	0.1	
Differential input common Mode voltage	V _{CM}	-	1	1.2	1.7 - 1 Vid 1/2	
LVDS input voltage	V _{INLV}	-	0.7	-	1.7	
Differential input voltage	V _{id}	-	0.1	-	0.6	
Differential input leakage current	I _{lvleak}	-	-10	-	10	

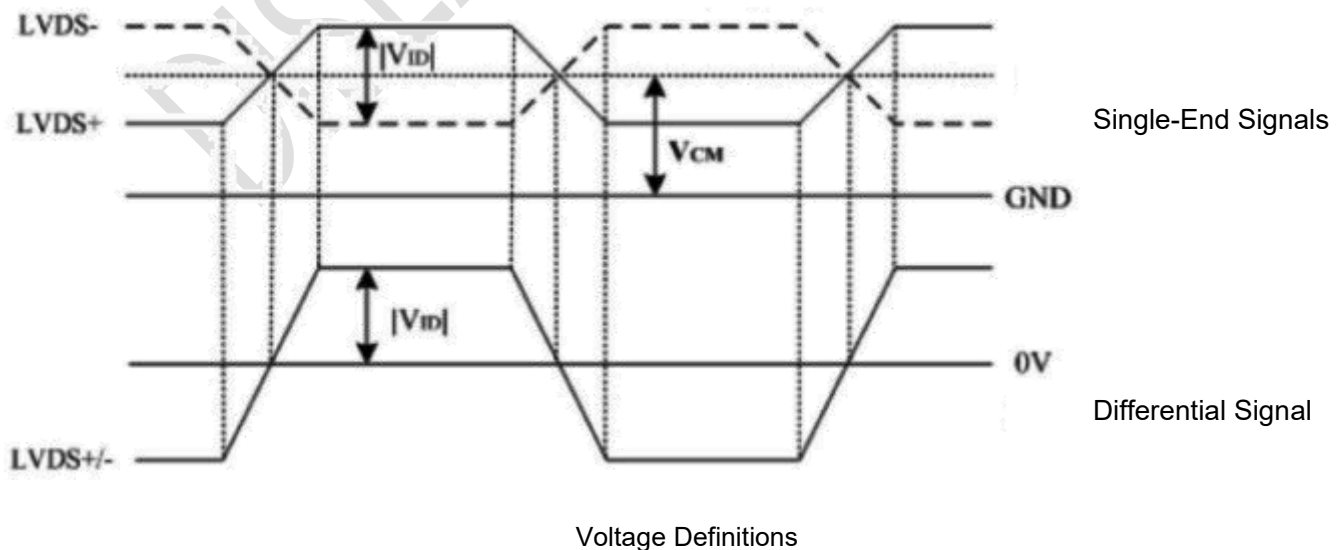

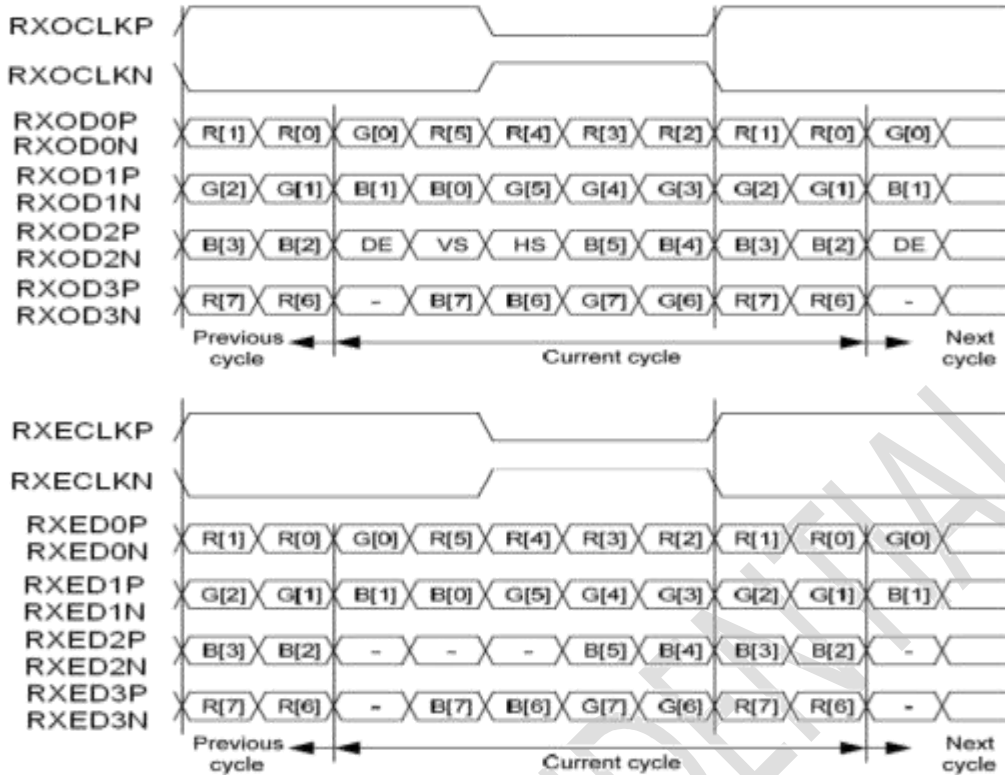

Data Mapping

6.4 POWER SEQUENCE

prevent a latch-up or DC operation of the LCD module, the power on/off sequence shall be as shown in below.

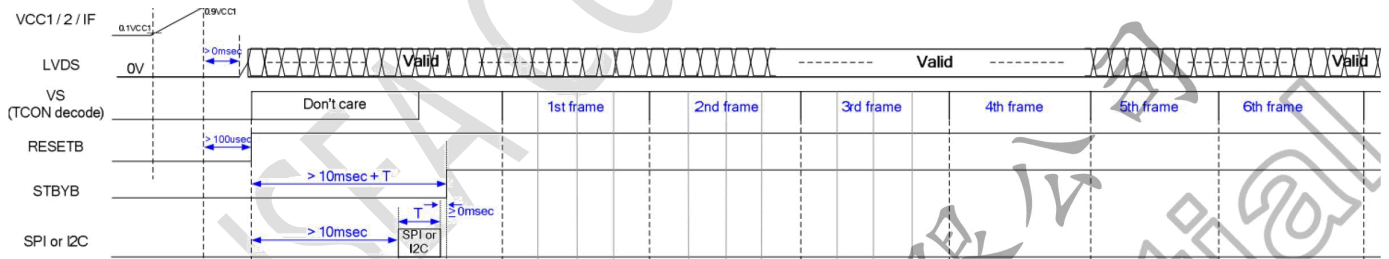

Power-on Sequence

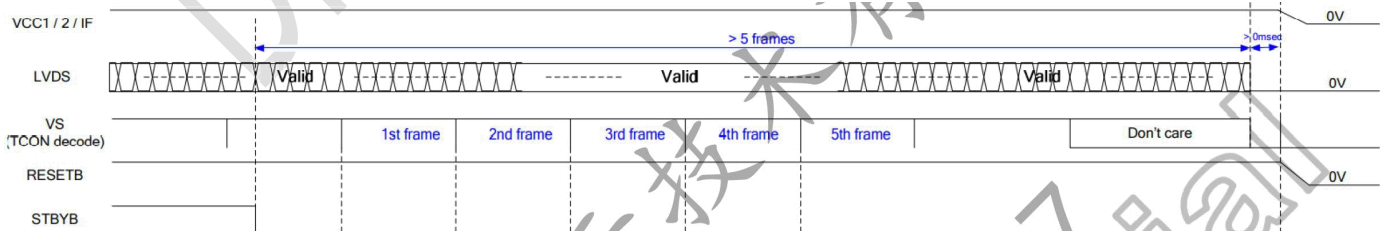

Power-off Sequence

7. Optical Characteristics

Item	Symbol	Condition	Min.	Typ.	Max.	Unit	Note
Brightness	Bp	$\theta=0^\circ$	800	1000	-	Cd/m ²	1
Uniformity	ΔBp	$\Phi=0^\circ$	80	85	-	%	1,2
Viewing Angle	3:00	Cr \geq 10	80	85	-	Deg	3
	6:00		80	85	-		
	9:00		80	85	-		
	12:00		80	85	-		
Contrast Ratio	Cr	$\theta=0^\circ$ $\Phi=0^\circ$	1200	1500	-	-	4
Response Time	T _r		-	30	-	ms	5
	T _f	-	-	-	ms		
Color of CIE Coordinate	W	x	Typ -0.05	0.302	Typ +0.05	-	1,6
		y		0.329		-	
	R	x		0.657		-	
		y		0.320		-	
	G	x		0.283		-	
		y		0.606		-	
	B	x		0.138		-	
		y		0.104		-	
NTSC Ratio	S		70	75	-	%	

Note: The parameter is slightly changed by temperature, driving voltage and material

Note 1: The data are measured after LEDs are turned on for 5 minutes. LCM displays full white.

The brightness is the average value of 9 measured spots. Measurement equipment BM-7 (Φ5mm)

Measuring condition:

- Measuring surroundings: Dark room.
- Measuring temperature: Ta=25°C.

- Adjust operating voltage to get optimum contrast at the center of the display.

Measured value at the center point of LCD panel after more than 5 minutes while backlight turning on.

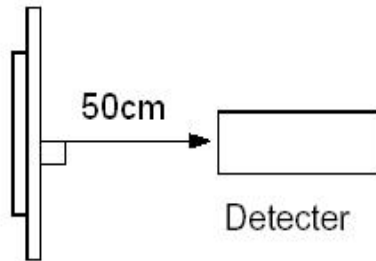

Note 2: The luminance uniformity is calculated by using following formula.

$$\Delta Bp = Bp (\text{Min.}) / Bp (\text{Max.}) \times 100 (\%)$$

$Bp (\text{Max.})$ = Maximum brightness in 9 measured spots

$Bp (\text{Min.})$ = Minimum brightness in 9 measured spots.

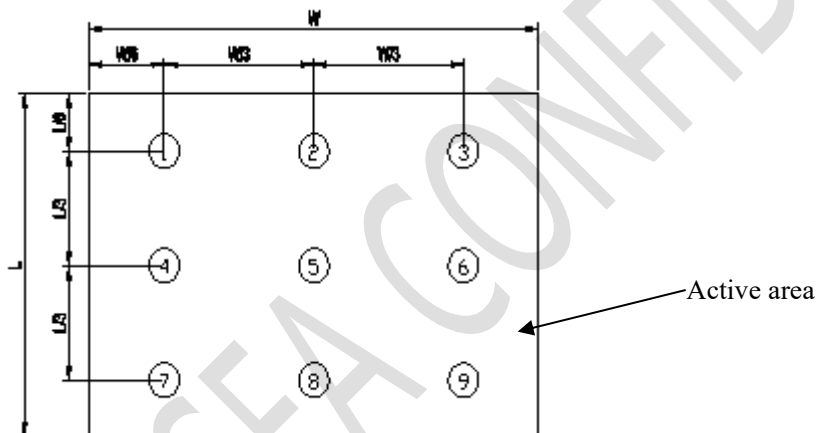

Note 3: The definition of viewing angle:

Refer to the graph below marked by θ and Φ

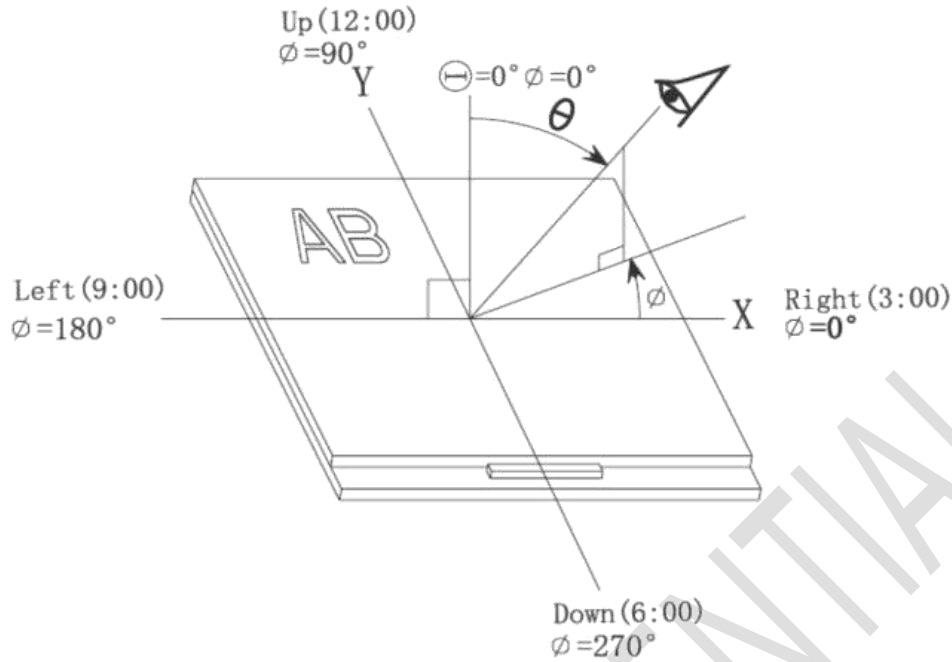

Note 4: Definition of contrast ratio.(Test LCD using DMS501)

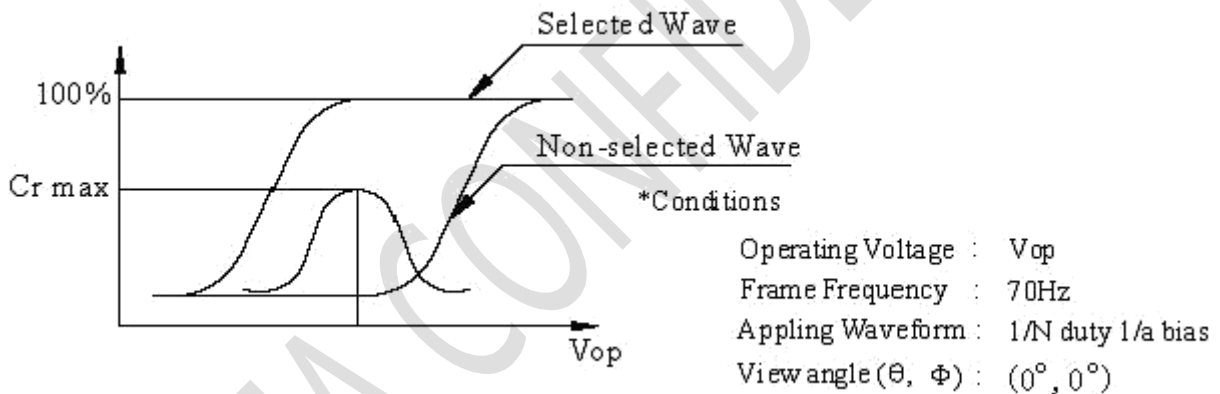

$$\text{Contrast ratio}(Cr) = \frac{\text{Brightness of selected dots}}{\text{Brightness of non-selected dots}}$$

Note 5: Definition of Response time. (Test LCD using DMS501):

The output signals of photo detector are measured when the input signals are changed from “black” to “white”(falling time) and from “white” to “black”(rising time), respectively. The response time is defined as the time interval between the 10% and 90% of amplitudes.Refer to figure as below.

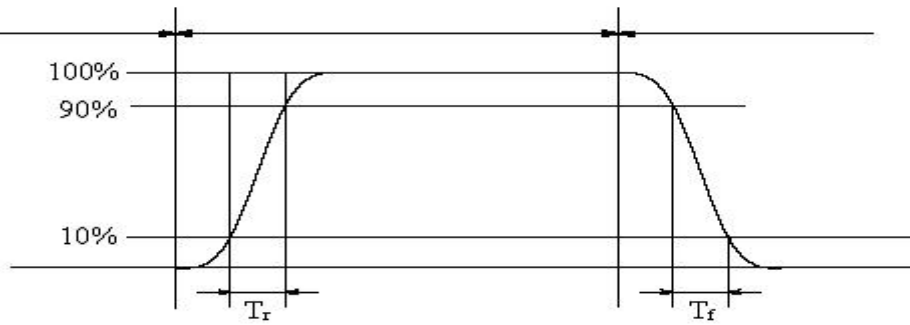

The definition of response time`

Note 6: Definition of Color of CIE Coordinate and NTSC Ratio.

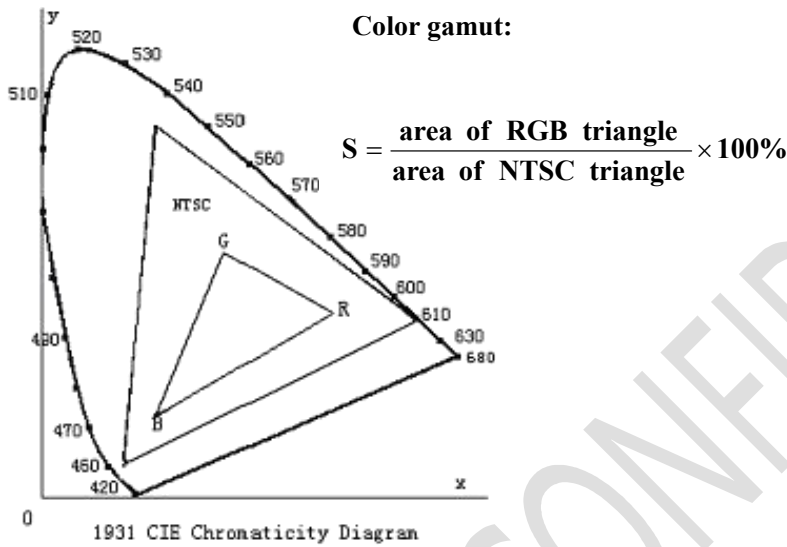

Note 7: Definition of cross talk.

Cross talk ratio(%)=|pattern A Brightness-pattern B Brightness|/pattern A Brightness*100

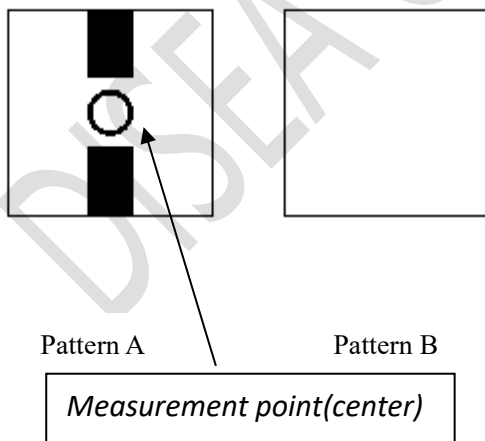

Electric volume value=3F+/-3Hex

8. Reliability Test Items and Criteria

Test Item	Test condition	Remark
High Temperature Storage	Ta = 90°C 500hrs	Note1,Note4
Low Temperature Storage	Ta = -40°C 500hrs	Note1,Note4
High Temperature Operation	Ts = 85°C 500hrs	Note2,Note4
Low Temperature Operation	Ta = -30°C 500hrs	Note1,Note4
Operation at High Temperature/Humidity	+65°C, 90%RH 500hrs	Note4
Thermal Shock	-40°C(30min) → +85°C(30min), 100 cycles	Note4
Vibration Test (Box)	Random 0.015G ² /Hz from 5-200Hz -6dB/octave from 200-500Hz 1hrs for X/Y/Z, total 3hrs	
Electrostatic Discharge (operation)	R=330Ω, C=150pF, 5 points/panel Contact = ± 8 kV, class B; Air = ± 15 kV, class B; 1 time for each point.	
Package Drop Test	With package, one corner/three edge/six face Height: 76.20cm 0.45~9.52Kg 60.96cm 9.52~18.59Kg 45.72cm 18.59~27.66Kg 30.48cm 27.66~45.35 kg	

Note 1: Ta is the ambient temperature of samples.

Note 2: Ts is the temperature of panel's surface.

Note 3: In the standard condition, there shall be no practical problem that may affect the display function. After the reliability test, the product only guarantees operation, but don't guarantee all of the cosmetic specification.

Note 4: Before cosmetic and function test, the product must have enough recovery time, at least 2 hours at room temperature

9. Precautions for Use of LCD Modules

9.1 Handling Precautions

9.1.1 The display panel is made of glass. Do not subject it to a mechanical shock by dropping it from a high place, etc.

9.1.2 If the display panel is damaged and the liquid crystal substance inside it leaks out, be sure not to get any in your mouth, if the substance comes into contact with your skin or clothes, promptly wash it off using soap and water.

9.1.3 Do not apply excessive force to the display surface or the adjoining areas since this may cause the color tone to vary.

9.1.4 The polarizer covering the display surface of the LCD module is soft and easily scratched. Handle this polarizer carefully.

9.1.5 If the display surface is contaminated, breathe on the surface and gently wipe it with a soft dry cloth. If still not completely clear, moisten cloth with one of the following solvents:

— Isopropyl alcohol — Ethyl alcohol

Solvents other than those mentioned above may damage the polarizer. Especially, do not use the following:

— Water — Ketone — Aromatic solvents

9.1.6 Do not attempt to disassemble the LCD Module.

9.1.7 If the logic circuit power is off, do not apply the input signals.

9.1.8 To prevent destruction of the elements by static electricity, be careful to maintain an optimum work environment.

- a. Be sure to ground the body when handling the LCD Modules.
- b. Tools required for assembly, such as soldering irons, must be properly ground.
- c. To reduce the amount of static electricity generated, do not conduct assembly and other work under dry conditions.
- d. The LCD Module is coated with a film to protect the display surface. Be care when peeling off this protective film since static electricity may be generated.

9.2 Storage precautions

9.2.1 When storing the LCD modules, avoid exposure to direct sunlight or to the light of fluorescent lamps.

9.2.2 The LCD modules should be stored under the storage temperature range. If the LCD modules will be stored for a long time, the recommend condition is:

Temperature : 0°C ~ 40°C

Relatively humidity: ≤80%

9.2.3 The LCD modules should be stored in the room without acid, alkali and harmful gas.

9.3 The LCD modules should be no falling and violent shocking during transportation, and also should avoid excessive press, water, damp and sunshine.

“Disea Electronics Co., Ltd. reserves the right to change this specification.”

ADD: 5F,#3 Building,TianFuAn Industrial park,LeZhuJiao,ZhouShi Road,
XiXiang Town,BaoAn District,ShenZhen City,GuangDong Province,China

URL:<http://www.diseaelec.com>

- END