

## Data sheet

Commercial Art.No.: 55.503.1053.0

Feed-through terminal WKM 2,5 / 15/V0

Feed-through terminal with Screw connection for mounting on TS 15 , nominal cross section: 2.5 mm<sup>2</sup>, width: 5 mm, color: grey

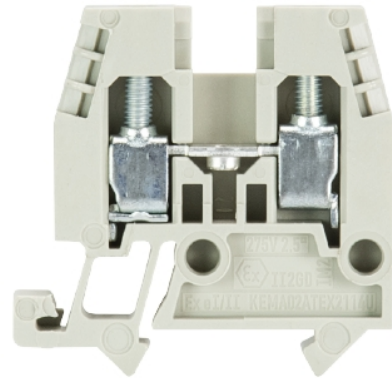

Commercial Art.No.	55.503.1053.0
EAN	4015573210257
Order Unit	100

Certificates / Approvals



CAN-EX



ATEX



USA-EX

## Technical data

### General

Nominal cross section	2.5 mm <sup>2</sup>
Color	Grey
Number of levels	1
Number of clamp positions per level	2
Width/grid dimension	5 mm
Insulating housing	PA666
Inflammability class of insulation material acc. with UL94	V0
Explosion-tested version "Ex e"	yes
Mounting method	DIN rail (top hat rail) 15 mm
Terminal blocks for electrical installations	yes

### Technical data

Rated current	25 A
Rated voltage	500 V
Rated impulse voltage	6 kV
Pollution degree	3
Closing plate required	yes
Type of insulation material	Thermoplastic
Length	32 mm

### Connection Data

Connection type 1	screw connection
-------------------	------------------

Connection type 2	screw connection
Minimum cross section solid	0.5 mm <sup>2</sup>
Maximum cross section solid	4 mm <sup>2</sup>
Minimum cross section fine stranded	0.5 mm <sup>2</sup>
Maximum cross section fine stranded	2.5 mm <sup>2</sup>
Wire strip length	9 mm
Torque conductor mounting	0.4 Nm

#### Technical Data UL/CSA

Cross section UL	22-14 AWG
Voltage UL	300 V
Current factory wiring	10 A
Current field wiring	10 A
Cross section CSA	22-12 AWG
Voltage CSA	600 V
Current CSA	25 A

#### Classification

ECLASS 11	
ECLASS 8.1	27141120
ETIM 7.0	EC000897
ETIM 6.0	EC000897
ETIM 5.0	EC000897
ETIM 4.0	EC000897
ETIM 3.0	EC000897

#### Product compliance

ROHS conformity status	Compliant
REACH-SVHC conformity status	Compliant

#### Accessories

Commercial Art.No.:	Article-type description:	Description:
Z7.215.4227.0	Jumper bar VB WKM 2,5 / 15 - 2	Cross connector for DIN rail terminal blocks type WKM 2.5, 2 -pole
Z7.215.4327.0	Jumper bar VB WKM 2,5 / 15 - 3	Cross connector for DIN rail terminal blocks type WKM 2.5, 3 -pole
Z7.215.4427.0	Jumper bar VB WKM 2,5 / 15 - 4	Cross connector for DIN rail terminal blocks type WKM 2.5, 4 -pole
Z7.215.4527.0	Jumper bar VB WKM 2,5 / 15 - 5	Cross connector for DIN rail terminal blocks type WKM 2.5, 5 -pole
Z7.215.4627.0	Jumper bar VB WKM 2,5 / 15 - 6	Cross connector for DIN rail terminal blocks type WKM 2.5, 6 -pole
98.090.0015.0	Mounting rail TS 15 PERF - l:2000mm	Mounting rail TS 15, slotted, Höhe 5,5 mm, length 2 m, material steel. galv. zinc-plated and dichromated
07.311.0853.0	End plate APM 2,5 - 4 / 15	End plate for DIN rail terminal blocks type WKM 2,5... und WKM 4..., color: grey
07.311.0853.6	End plate APM 2,5 - 4 / 15 BLAU	End plate for DIN rail terminal blocks type WKM 2,5... und WKM 4..., color: blue
07.311.1853.0	Partition TWM 2,5 - 4 / 15	Partition for DIN rail terminal blocks type WKM 2,5... and WKM 4..., color: grey
04.242.5053.0	Marking tag strips 9705 A / 5 / 10	Marking tag strips for DIN rail terminal blocks type 9700 A / 5..., 10 tags per strip, color: blue, unmarked, markable with Wieplot plotter-system

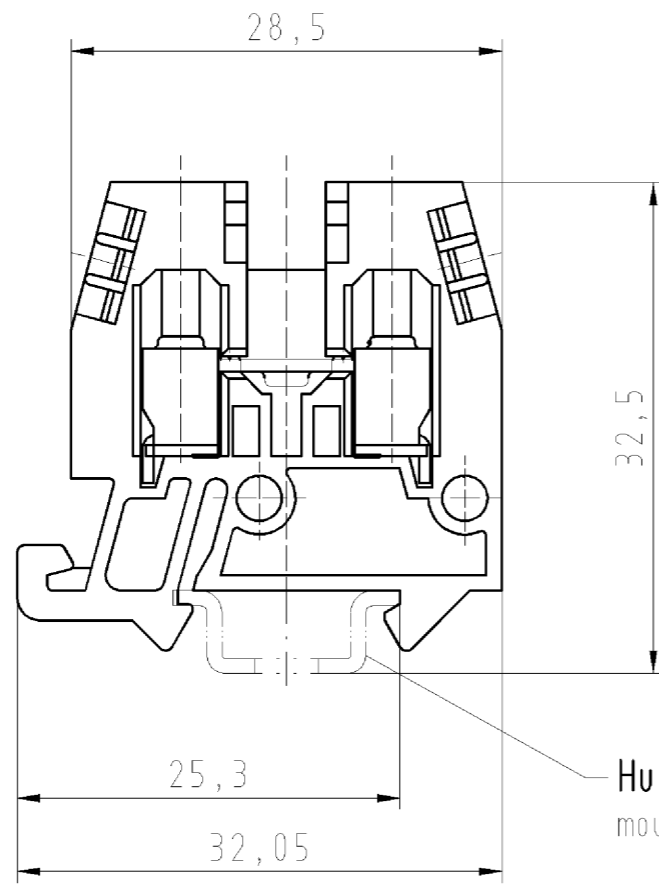

Hutschiene EN 60715-15x5,5  
mountail-rail EN 60715-15x5,5

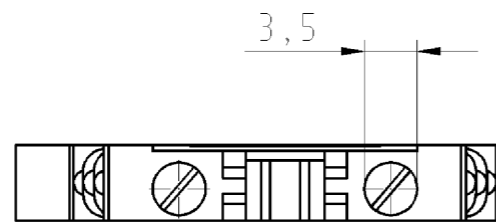
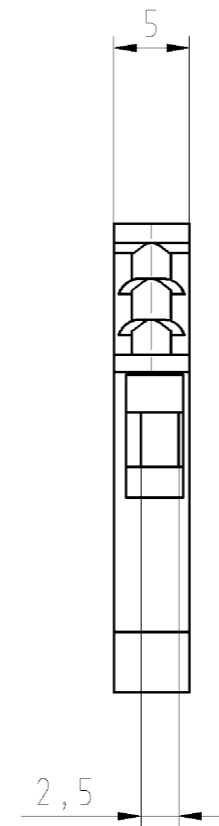

Weitere Daten siehe Katalog  
further data see catalog

Teile-Nr./part-nr.	Farbe/colour	Typ/type
55.503.1053.0	grau/grey	WKM 2,5/15/V0
55.503.1053.1	schwarz/black	WKM 2,5/15 SW/V0
55.503.1053.2	weiß/white	WKM 2,5/15 WEIß/V0
55.503.1053.4	braun/brown	WKM 2,5/15 BRAUN/V2
55.503.1053.5	rot/red	WKM 2,5/15 ROT/V0
55.503.1053.6	blau/blue	WKM 2,5/15 BLAU/V0
55.503.1053.7	grün/green	WKM 2,5/15 GRÜN/V0
55.503.1053.8	gelb/yellow	WKM 2,5/15 GELB/V0
55.503.1053.9	orange/orange	WKM 2,5/15 ORANGE/V0

Freitoleranz nach DIN		CAD - Zeichnung, keine manuellen Änderungen			1. Verwendung: -		Bl.: 1 von 1	
	Maßstab	2003	Tag	Name	T	Zeichnung Nr.		Index
	2:1	Entworfen	11.04.	Scmitt J.		55.503.1053.0 01K		
		Geprüft	-	-		Ersatz für: -		
		<b>wieland</b> Elektrische Verbindungen			Benennung <b>DURCHGANGSKLEMME</b> terminal			
Buchstabe	Datum / Blatt							
Änderung								

Diese Maße werden bei Abnahme besonders geprüft  
 Ausschließlich Prüfmäße  
 Mit /E gekennzeichnete Maße sind nur für interne Zwecke gültig

Weitergabe sowie Vervielfältigung dieses Dokuments, Verwertung und Mitteilung  
 seines Inhalts sind verboten, soweit nicht ausdrücklich gestattet.  
 The reproduction, distribution and utilization of this document as well as the  
 communication of its contents to others without express authorization is prohibited.