



9097247 TOSHIBA, ELECTRONIC

02E 16987 D

**TA7270P**  
**TA7271P**

T-74-05-01

## MAXIMUM RATINGS (Ta=25°C)

CHARACTERISTIC	SYMBOL	RATING	UNIT
Peak Supply Voltage (0.2 sec)	V <sub>CC</sub> surge	45	V
DC Supply Voltage	V <sub>CC</sub> DC	25	V
Operating Supply Voltage	V <sub>CC</sub> opr	18	V
Output Current (peak)	I <sub>O</sub> (peak)	4.5	A
Power Dissipation	P <sub>D</sub>	25	W
Operating Temperature	T <sub>opr</sub>	-30 ~ 75	°C
Storage Temperature	T <sub>stg</sub>	-55 ~ 150	°C

## ELECTRICAL CHARACTERISTICS

(Unless otherwise specified, V<sub>CC</sub>=13.2V, R<sub>L</sub>=4Ω, R<sub>g</sub>=600Ω, f=1kHz, Ta=25°C)

CHARACTERISTIC	SYMBOL	TEST CIR-CUIT	TEST CONDITION	MIN.	TYP.	MAX.	UNIT
Quiescent Current	ICCQ	2	V <sub>IN</sub> =0	-	80	145	mA
BTL CONNECTION MODE	Output Power	POUT(1)	1 THD=10%	16	19	-	W
		POUT(2)	1 THD=1%	12	15	-	W
	Total Harmonic Distortion	THD(1)	1 P <sub>OUT</sub> =4W, G <sub>v</sub> =40dB	-	0.03	0.25	%
	Output Offset Voltage	V <sub>OFF</sub>	1 V <sub>IN</sub> =0	-	0	0.35	V
	Voltage Gain	G <sub>v</sub> (1)	1 V <sub>OUT</sub> =0dBm	-	40	-	dB
	Output Noise Voltage	V <sub>N</sub> O(1)	1 R <sub>g</sub> =0 DIN45405 Noise Filter	-	0.14	-	mV <sub>rms</sub>
Ripple Rejection Ratio	R.R(1)	1 f <sub>ripple</sub> =100Hz V <sub>ripple</sub> =0dBm	-	-52	-40	dB	
DUAL MODE	Output Power	POUT(3)	2 THD=10%	5	5.8	-	W
	Total Harmonic Distortion	THD(2)	2 P <sub>OUT</sub> =1W	-	0.06	0.30	%
	Voltage Gain	G <sub>v</sub> (2)	2 V <sub>OUT</sub> =0dBm	50	52	54	dB
	Voltage Gain Ratio	ΔG <sub>v</sub>	2 V <sub>OUT</sub> =0dBm	-1	0	1	dB
	Output Noise Voltage	V <sub>N</sub> O(2)	2 R <sub>g</sub> =10kΩ BW=20Hz ~ 20kHz	-	0.7	1.5	mV <sub>rms</sub>
	Ripple Rejection Ratio	R.R(2)	2 f <sub>ripple</sub> =100Hz V <sub>ripple</sub> =0dBm	-	-52	-40	dB
	Cross Talk	C.T	2 V <sub>OUT</sub> =0dBm	-	-57	-	dB
Input Resistance	R <sub>IN</sub>	2 f=1kHz	-	33	-	kΩ	

TOSHIBA

**TA7270P**  
**TA7271P**  
T-74-05-01

TEST CIRCUIT/APPLICATION CIRCUIT

TA7270P

(1) BTL AMPLIFIER

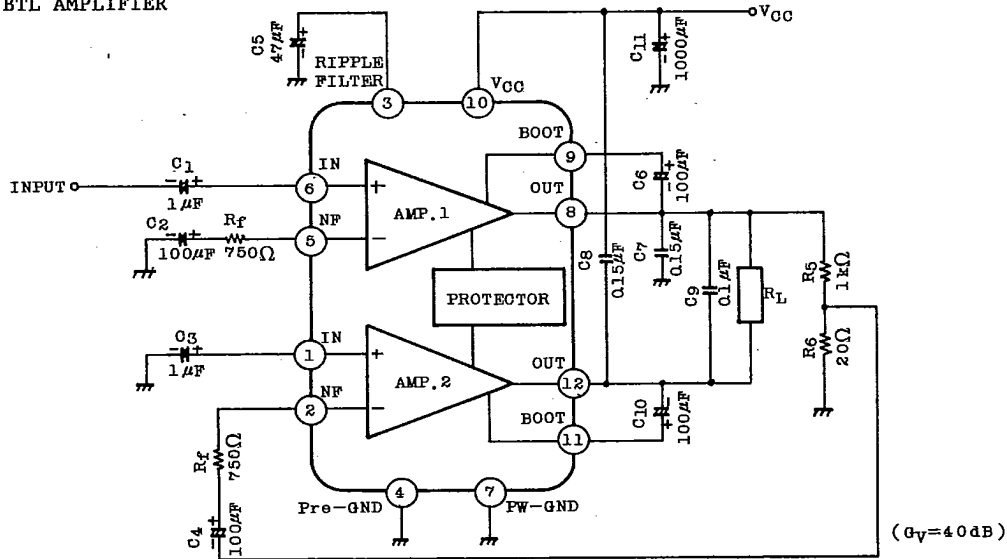

(2) DUAL AMPLIFIER

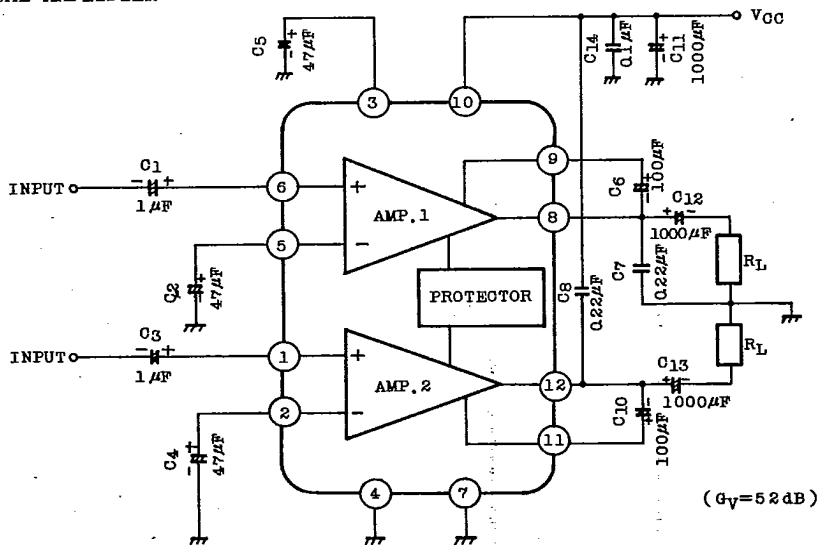

**AUDIO LINEAR IC**

**TA7270P**  
**TA7271P**

T-74-05-01

TEST CIRCUIT/APPLICATION CIRCUIT

TA7271P

(1) BTL AMPLIFIER

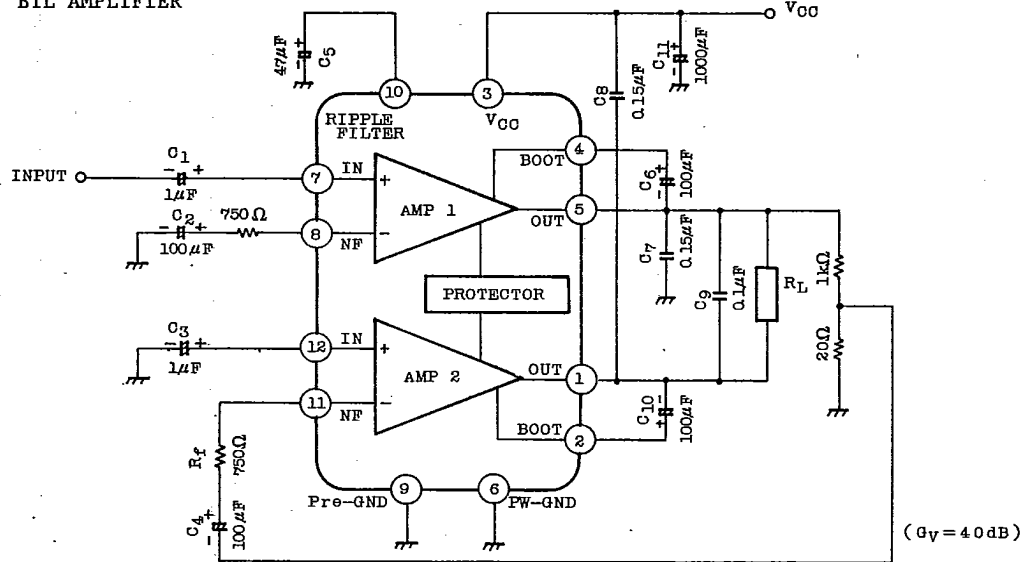

(2) DUAL AMPLIFIER

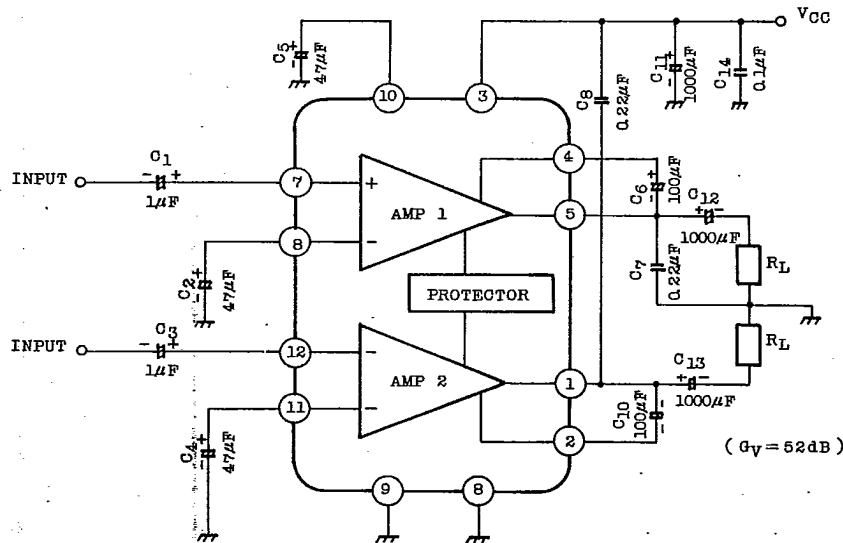

**TA7270P**  
**TA7271P**  
T-74-05-01

TYPICAL DC VOLTAGE OF EACH TERMINAL

(V<sub>CC</sub>=13.2V, T<sub>a</sub>=25°C, DUAL MODE TEST CIRCUIT)

TERMINAL No.	1	2	3	4	5	6	7	8	9	10	11	12	
DC Voltage (V)	TA7270P	1.5	1.5	4.4	GND	1.5	1.5	GND	6.6	12.7	V <sub>CC</sub>	12.7	6.6
	TA7271P	6.6	12.7	V <sub>CC</sub>	12.7	6.6	GND	1.5	1.5	GND	4.4	1.5	1.5

APPLICATION INFORMATION

(This explanatory terminal number is for TA7270P)

1. VOLTAGE GAIN

(1) Dual Mode

The closed loop voltage gain G<sub>v</sub> is determined by R<sub>1</sub>, R<sub>2</sub>, R<sub>3</sub>, R<sub>4</sub> and R<sub>f</sub>.

$$G_v \approx 20 \log \frac{R_2 + R_f + R_1}{R_f + R_1} + 20 \log \frac{R_3 + R_4}{R_4} \text{ (dB)}$$

when R<sub>f</sub>=0, G<sub>v</sub>=52dB(Typ.)

is given.

The recommended voltage gain is more than 40dB.

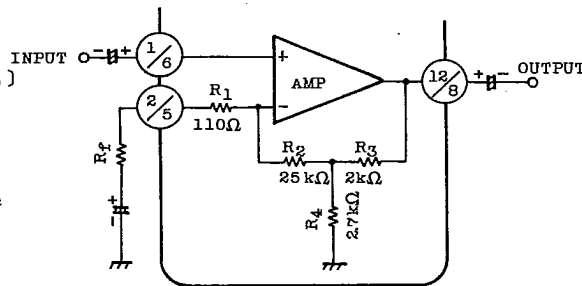

Fig 1

(2) BTL Mode

The recommended BTL connection amplifier is shown in Figure 2.

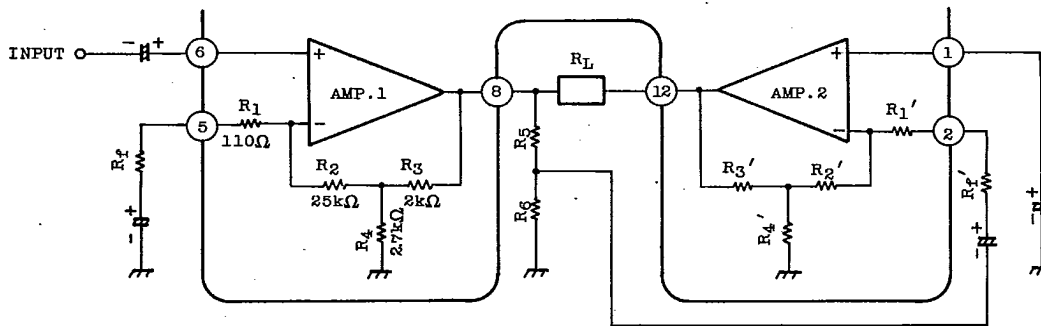

Fig. 2

# TA7270P

# TA7271P

T-74-05-01

AMP.1 is noninverting amplifier and AMP.2 is inverting one. The output voltage is divided by resistors R<sub>5</sub> and R<sub>6</sub>.

This divided voltage is applied to inverting input of AMP.2. R<sub>5</sub> and R<sub>6</sub> are determined in the following equation.

$$\frac{R_5+R_6}{R_5} = 20 \log \frac{R_1'+R_f'+R_2'}{R_1'+R_f'} + 20 \log \frac{R_3'+R_4'}{R_4'} \dots G_v \text{ in Dual Mode}$$

The voltage gain in this circuit is 6dB higher than that in dual mode.

$$G_v = 20 \log \frac{R_1+R_f+R_2}{R_1+R_f} + 20 \log \frac{R_3+R_4}{R_4} + 6 \quad [\text{dB}]$$

In case of R<sub>f</sub>=0

$$G_v = 52+6=58[\text{dB}]$$

In case of R<sub>f</sub>=750Ω

$$G_v = 34+6=40[\text{dB}]$$

## 2. MUTING

Audio muting can be accomplished by connecting pin ③ (ripple filter) to GND as shown in Fig.3.

Then, the bias circuits are cut off.

Amount of muting attenuation is more than 60dB.

Precaution in muting operation is as follows.

- (1) The recovery time at muting off depends on Capacitance C<sub>2</sub>, C<sub>4</sub> and C<sub>5</sub> in the test Circuit.
- (2) As this muting system is operated by the short-circuit of ripple filter : C<sub>5</sub>, the ripple rejection ratio becomes worse in a muting mode.

Note that some "POP-Noise" occur when bias is shut off with mute-on.

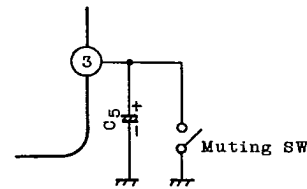

Fig.3

## 3. CAPACITOR C<sub>7</sub>, C<sub>8</sub>

The purpose of capacitor C<sub>7</sub>, C<sub>8</sub> is to prevent oscillation.

These capacitors need to be small temperature coefficient. So celamic capacitor is unsuitabel.

A voltage gain less than 40dB results occasionally in a parastic oscillation.

Stability for parastic oscillation is promoted by connecting capacitor of 500~1000pF between pin ① and pin ② (pin ⑤ and pin ⑥).

The additional capacitors are recommended to be inserted.

9097247 TOSHIBA. ELECTRONIC

02E 16992 D

TA7270P

TA7271P

T-74-05-01

#### 4. PRECAUTION AT PRINT BOARD DESIGN

- (1) Print Pattern board should be designed in consideration of stability for parastic oscillation.

The following parts-layout is recommended.

- 1st. Capacitors C6 and C10 are spaced most close to the output pin.
  - 2nd. Capacitor C7 or C8 is spaced close to the output pin next to C6 and C10.
  - 3rd. Capacitor C9 is spaced close to it next to C7 and C8.
  - 4th. Capacitor C11 is spaced close to it next to C9.
- (2) Input line (pin ⑥) and PW-GND line (pin ⑦) should not be spaced in parallel. In the paralalled layout, output current signal in PW-GND line is bed back to input line by electromagnetic coupling. Then it deteriorates the total harmonic distortion, especially at high audio frequency region.
- (3) Undesirable terminating of capacitors deteriorates "pop" noise or THD. Capacitors C2, C4 and C5 should be terminated to Pre-GND (pin ④). Capacitors C7, C11, and C14 should be terminated to PW-GND (pin ⑦).
- (4) It is recommended to refer the standard print board.

AUDIO LINEAR IC

**TA7270P**  
**TA7271P**

T-74-05-01

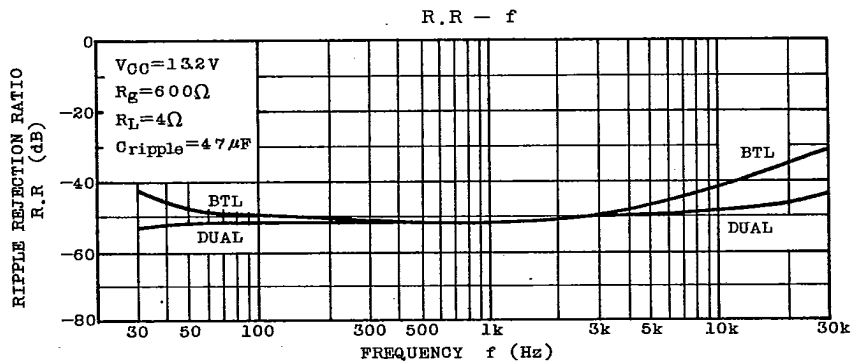
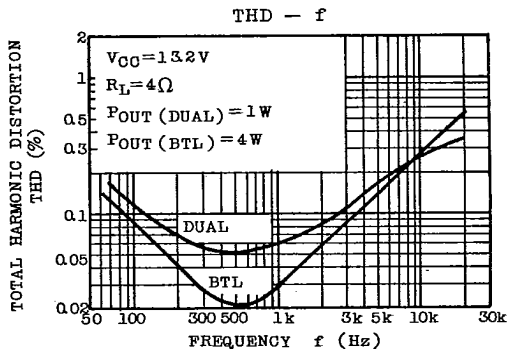
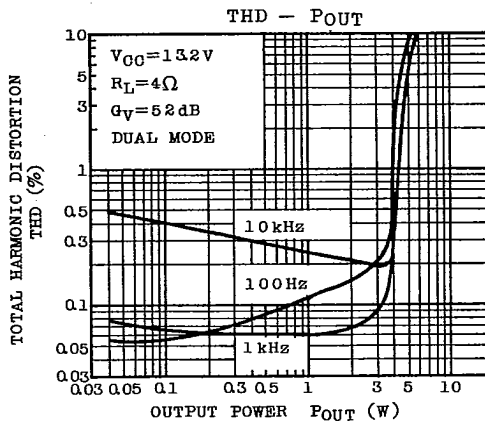
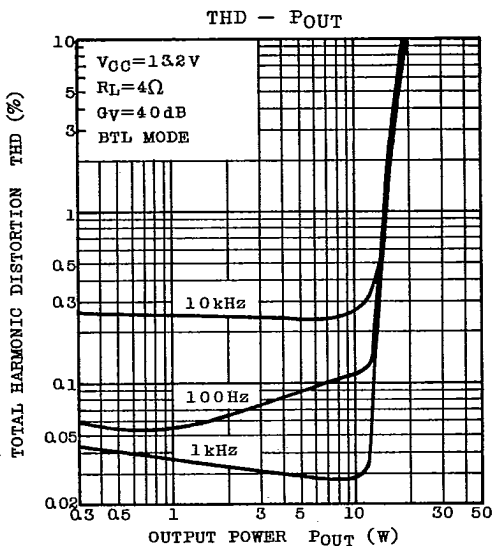



9097247 TOSHIBA, ELECTRONIC

02E 16994 D

**TA7270P**  
**TA7271P**

T-74-05-01

C.T - f

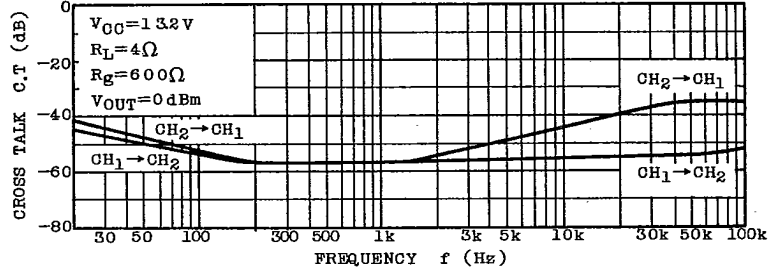

G<sub>V</sub> - f

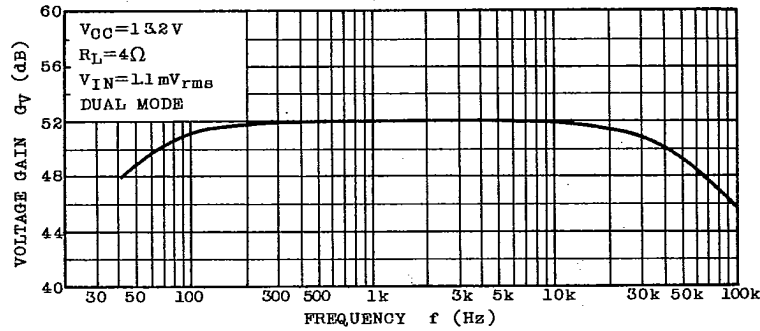

V<sub>NO</sub> - R<sub>g</sub>

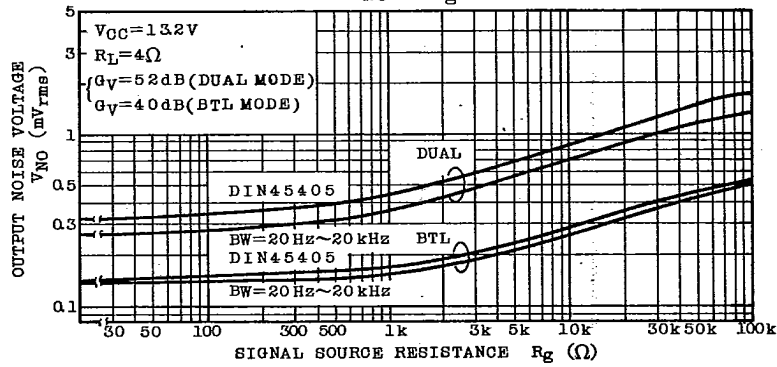

AUDIO LINEAR IC

**TA7270P**  
**TA7271P**

T-74-05-01

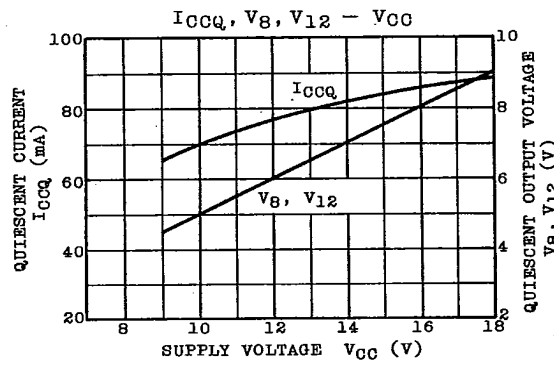
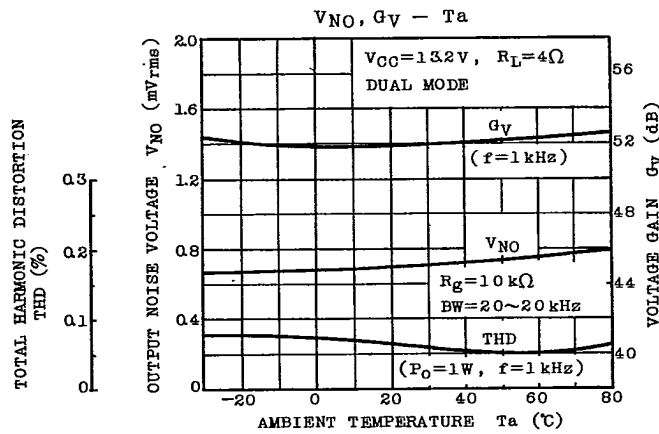
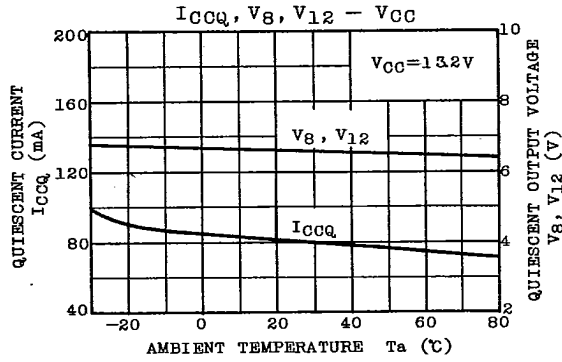

**TA7270P**  
**TA7271P**

T-74-05-01

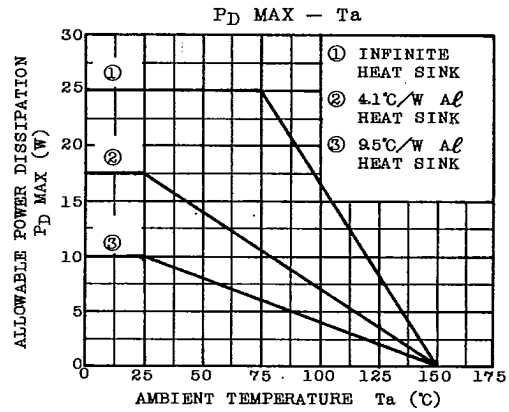
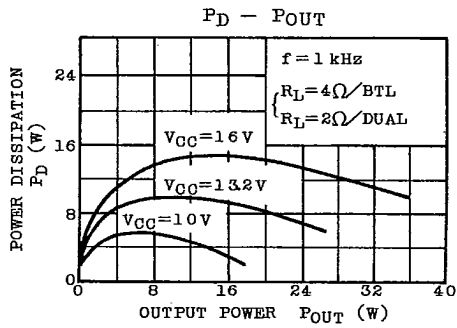
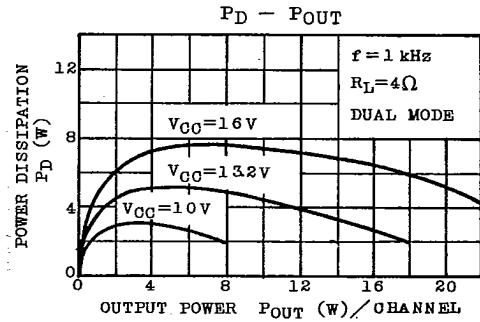
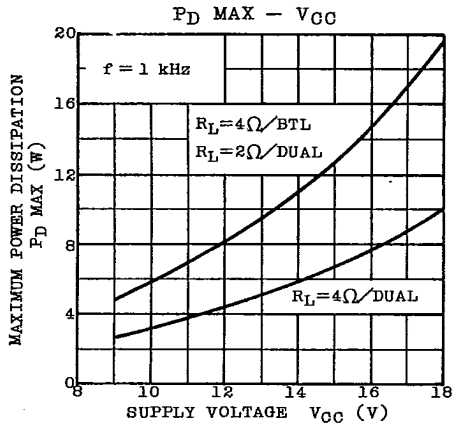

AUDIO LINEAR IC