

Rev.	Description	Date
A0	New release	2023.11.29

1. PHYSICAL CHARACTERISTICS (mm)

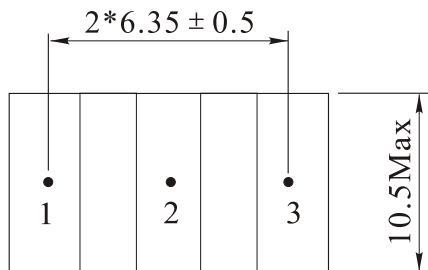

2. ELECTRONICAL SCHEMATIC

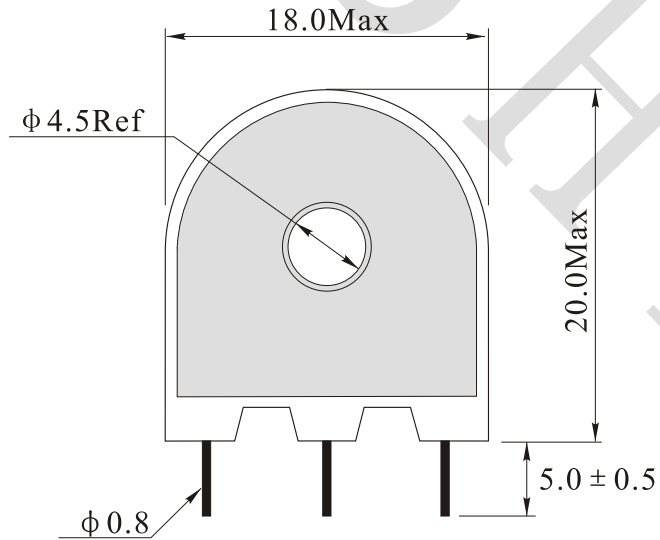
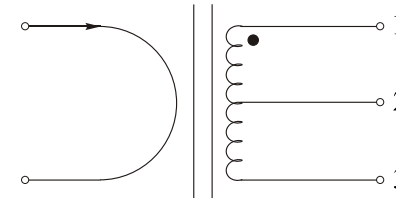

3. ELECTRONICAL SPECIFICATIONS

Turns ratio: Pri:Sec=1:200CT

Sec Inductance(1-3): 80mH Min@10KHz,0.1V

Sec DCR(1-3): 4.5Ω Max

ET: 600V-uSec Max

Hi-Pot: 2000Vrms, Pri to Sec

Operating temperature: -25°C to +85°C

Note:

- 1.Solderability:leads shall meet MIL-STD-202, Method 208D for solder ability.
- 2.Flammability: UL94V-0
- 3.ASTM oxygen index: >28%

NAME:	Current transformer		
CUSTOMER P/N:		DATE:	2023-11-29
SHINHOM P/N:	ACST-007	REV: A0	PAGE
DRAWN BY	CHECKED BY	APPROVE BY	



SHINHOM
SHAANXISHINHOM ENTERPRISE CO LTD

The Document property belong to SHINHOM & is not allowed to be duplicated without authorization