



OWP_H Series

Quick Guide

For product support, visit : www.owon.com.hk/download

Oct. 2022 edition V1.0.1

Copyright © LILLIPUT Company. All rights reserved.

The LILLIPUT's products are under the protection of the patent rights, including ones which have already obtained the patent rights and those which are applying for. The information in this manual will replace all that in the materials published originally.

The information in this manual was correct at the time of printing. However, LILLIPUT will continue to improve products and reserves the rights to change specification at any time without notice.

owon[®] is the registered trademark of the LILLIPUT Company.

Fujian LILLIPUT Optoelectronics Technology Co., Ltd.

No. 19, Heming Road

Lantian Industrial Zone, Zhangzhou 363005 P.R. China

Tel: +86-596-2130430

Fax: +86-596-2109272

Web: www.owon.com

E-mail: info@owon.com.cn

General Warranty

We warrant that the product will be free from defects in materials and workmanship for a period of 2 years (1 year for accessories) from the date of purchase of the product by the original purchaser from our company. This warranty only applies to the original purchaser and is not transferable to a third party.

If the product proves defective during the warranty period, we will either repair the defective product without charge for parts and labour, or will provide a replacement in exchange for the defective product. Parts, modules and replacement products used by our company for warranty work may be new or reconditioned like new. All replaced parts, modules and products become the property of our company.

In order to obtain service under this warranty, the customer must notify our company of the defect before the expiration of the warranty period. Customer shall be responsible for packaging and shipping the defective product to the designated service centre, a copy of the customers proof of purchase is also required.

This warranty shall not apply to any defect, failure or damage caused by improper use or improper or inadequate maintenance and care. We shall not be obligated to furnish service under this warranty a) to repair damage resulting from attempts by personnel other than our company representatives to install, repair or service the product; b) to repair damage resulting from improper use or connection to incompatible equipment; c) to repair any damage or malfunction caused by the use of not our supplies; or d) to service a product that has been modified or integrated with other products when the effect of such modification or integration increases the time or difficulty of servicing the product.

Please contact the nearest Sales and Service Offices for services.

Excepting the after-sales services provided in this summary or the applicable warranty statements, we will not offer any guarantee for maintenance definitely declared or hinted, including but not limited to the implied guarantee for marketability and special-purpose acceptability. We should not take any responsibilities for any indirect, special or consequent damages.

1 Back Panel

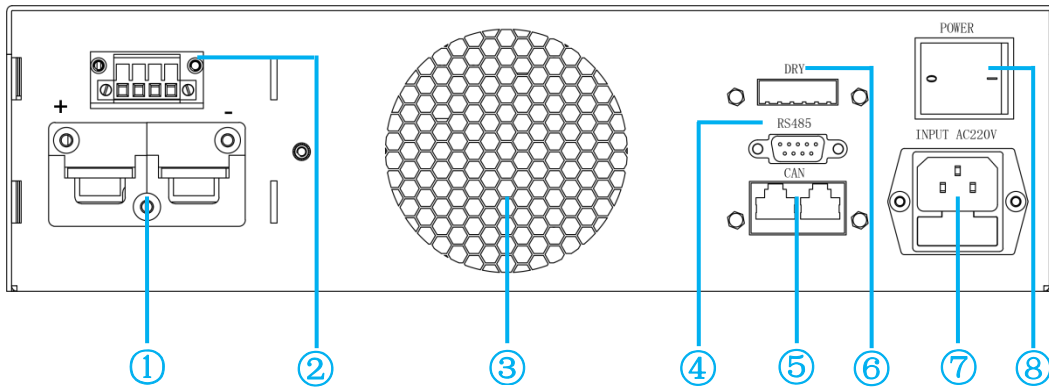

1kW model

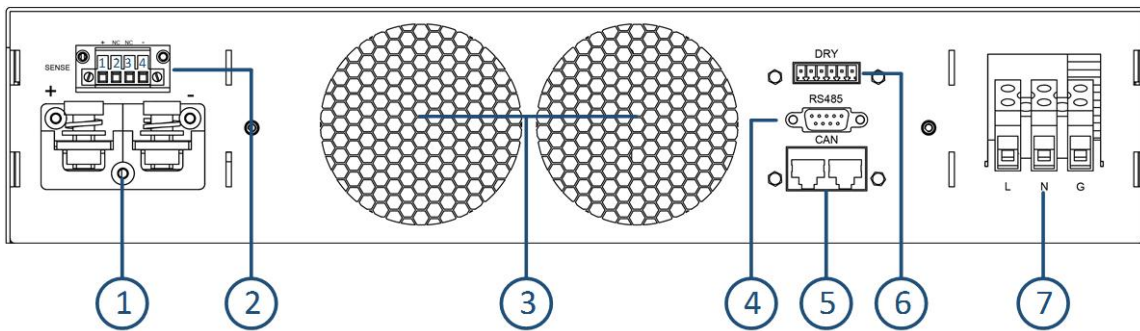

2kW & 3kW model

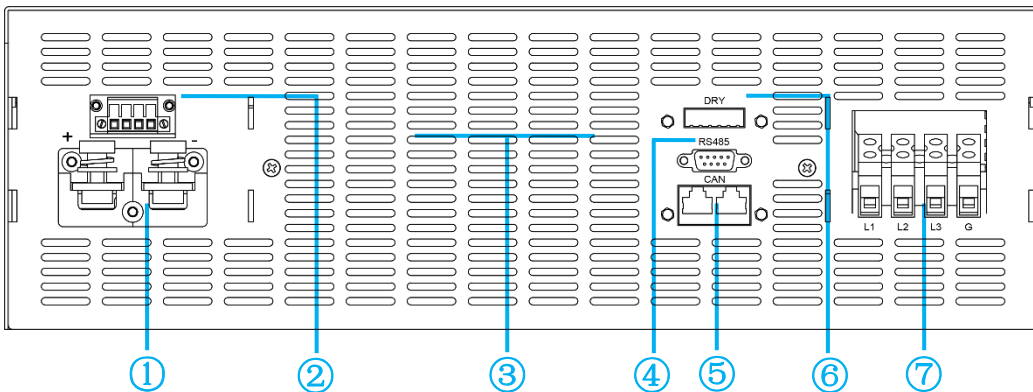

6kW & 8kW model

Figure 1: Back panel

- | | |
|---|---------------------------------|
| 1. DC output terminal: RED "+", BLACK "-" | 2. Remote voltage compensation |
| 3. Duct outlet (No obstructions within 10 cm) | 4. RS485 interface(Female) |
| 5. CAN interface | 6. Dry contact/Analog interface |
| 7. AC Input | 8. switch |

1.1 Interface

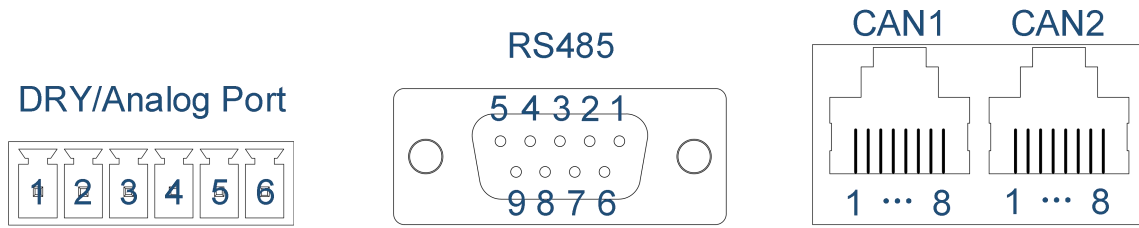

Figure 2: Interface

Interface	PIN	Function	Interface	PIN	Function
Digital IO	1	Normally open contact (Output of the dry contact)	Analog	1	Matching analog1 “+”
	2	Common contact (Output of the dry contact)		2	Matching analog1 “-”
	3	Normally closed contact (Output of the dry contact)		3	Matching analog1 “+”
	4	NC		4	Matching analog1 “-”
	5	Input of the dry contact		5	Input of the dry contact
	6			6	
RS485	1	485-A	CAN	2	CAN-L
	2	485-B		7	CAN-H
	3~9	NC		1/3~6/8	NC

Table 1: Defines of interface

- Digital IO interface: PIN 1 to 3 is a dry contact output interface with complementary functions of normally open and normally closed. PIN2 is the common end of the dry contact. Dry contact output capacity: 1A/30VDC or 0.15A/220VAC; PIN 5 to 6 are dry contact input interfaces, which can be set for external control of the output, external fault feedback, or external control of the buzzer;
- Analog interface: Analog interface is optional, interface signals can be customized, two analog interface definition as shown in the table above
- RS485 interface: Serial communication interface(Female), software using standard Modbus-RTU protocol;
- CAN interface: CAN1 and CAN2 are two internal parallel CAN bus interfaces, which facilitate serial or parallel connection between devices. CAN communication also be used for communication between external devices;

Note: Analog interface is optional interface (customizable), up to a maximum of four analog, two analog input and two analog output. Select 1-2 analog, interface see figure above; select 3-4 analog, interface is RJ45-CAN1, 1-8 pin is defined as the positive and negative of analog input 1, the positive and negative of analog input 2, the positive and negative of analog output 1, the positive and negative of analog output 2. If you need analog function, please inform us of the specific requirements in advance.

1.2 Voltage compensation

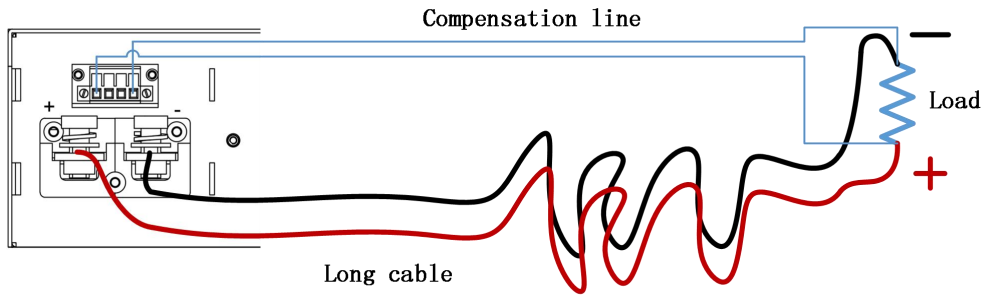

Figure 3: Schematic diagram of voltage compensation wiring

To use the remote voltage compensation function, use twisted-pair cables with high insulation. Positive and negative cables can not be connected inversely, as shown in the figure above. When not in use, the compensation terminals (SENSE) PIN1 and PIN2, PIN3 and PIN4 need to be shorted with short cables.

1.3 Parallel connection

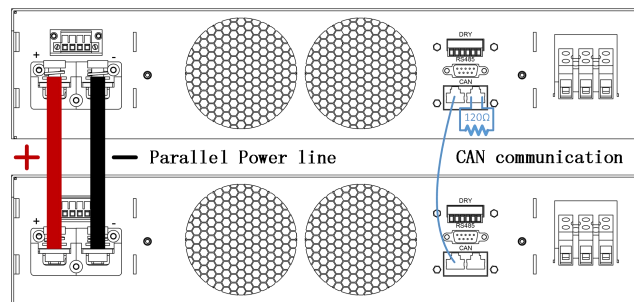

Figure 4: Parallel schematic diagram

The device identifies and controls the parallel output through CAN communication. The diagram above shows the parallel connection.

Note: 120 ohm is the CAN bus terminal resistor.

2 Front panel

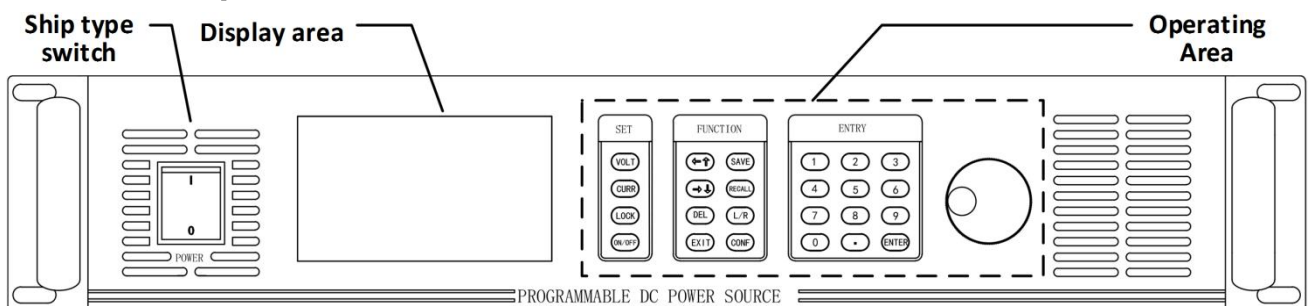

Figure 5: Front panel

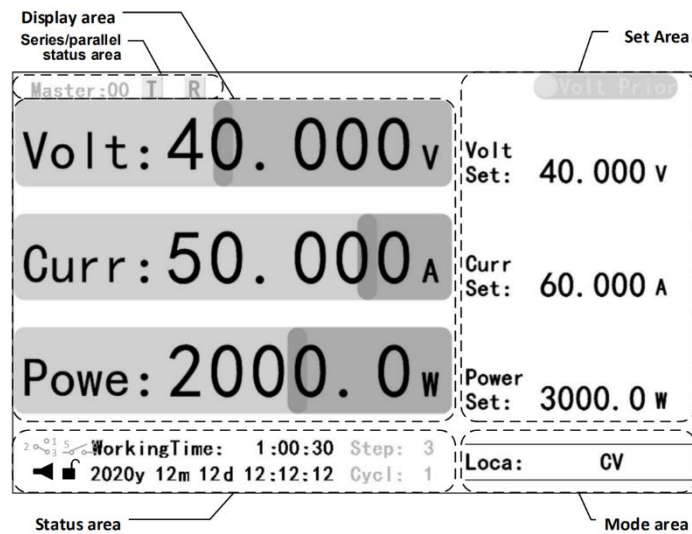

Figure 6: Display area

2.1 Display area

The Home displays real-time operating status information of the device, including:

- Display area: Current real-time output information;
- Setting area: setting of voltage, current and power reference values, And voltage/current priority Settings;
- Status area: buzzer, lock key state, date and time information, working time, and dry contact and application mode state (gray);
- Mode area: Control mode and output mode;
- Series/parallel status area: when multiple machines are used in series/parallel, each device will display master/slave machine number and CAN data receiving and receiving status of the machine (gray);

Note: 1. Display elements of the status area can be hidden. When an application mode is enabled, the status of the application mode will be displayed, and when the dry contact is used, the corresponding status icon will be displayed.

2. Output mode is divided into common mode and application mode. 1. Common mode: CV(Constant voltage), CV(Constant current), CP(Constant power) or CV/CC/CP (Output is not open); 2. Application mode: such as CV Steps(Constant voltage steps), CC Steps(Constant current steps) and Hybrid steps in step mode.

2.1.1 Home

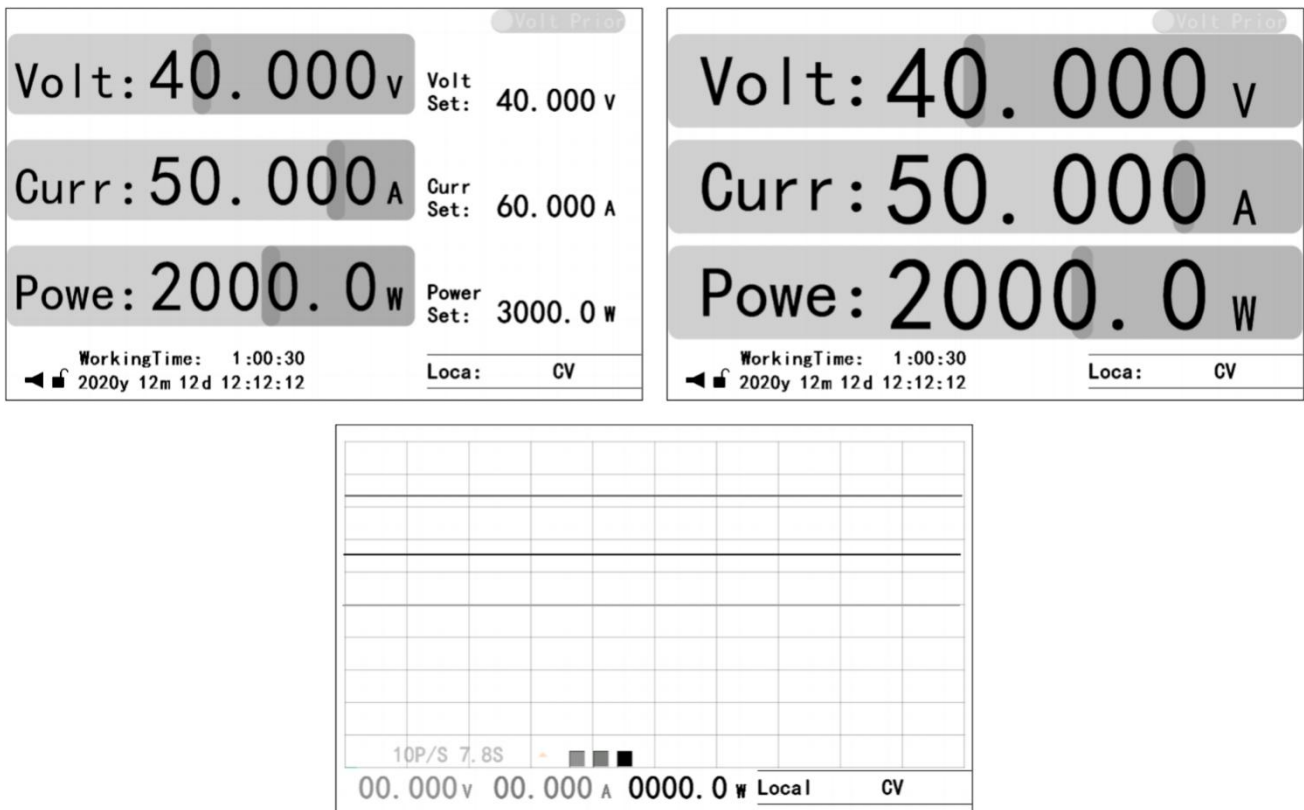

Figure 7: Homes

Three Homes, including:

- Home: displays the most comprehensive real-time working status information, detailed in the section of "Display Area";
- Auxiliary Home: maximizes the real-time output information;
- Waveform Home: displays output real-time information in an intuitive waveform manner.

Note: 1. The Home is the only interface for setting voltage, current and power reference values.

2. Press "ENTER" to set the sampling rate of the waveform displayed on the waveform Home. Whether the voltage, current and power waveform are displayed can be controlled by pressing "VOLT", "CURR" or "POWER" key.

2.2 Operating area

Key	Description
VOLT	Voltage reference set
CURR	Current reference set
VOLT Double Click	Voltage priority switching
CURR Double Click	Current priority switching
VOLT+CURR	Power reference set
LOCK	Lock/Unlock
ON/OFF	Output ON/OFF
←↑	Left/Up shift
→↓	Right/Down shift
DEL	Delete
EXIT	Returns the previous level or exit setting
SAVE	Save current settings
RECALL	Recall the saved settings
L/R	local/remote control mode
CONF	Function Menu

Key	Description
0~9	Number set
.	DOT
ENTER	To Menu/ Confirm input Switch between Home and Auxiliary Home
Knob	Description
Press	Menu Confirm Input Home : 1、 Press once, Voltage set 2、 Press twice, Current set 3、 Press 3 times, Power set
Clockwise rotation	Increase value Up shift
Anti-Clock rotation	Reduce value Down shift

Table 2: Key description

The operation area includes setting area, function area, digital area and knob. See "Appendix 1" in 《OWP_H Series Use Manual》 for key details.

2.2.1 Basic operation

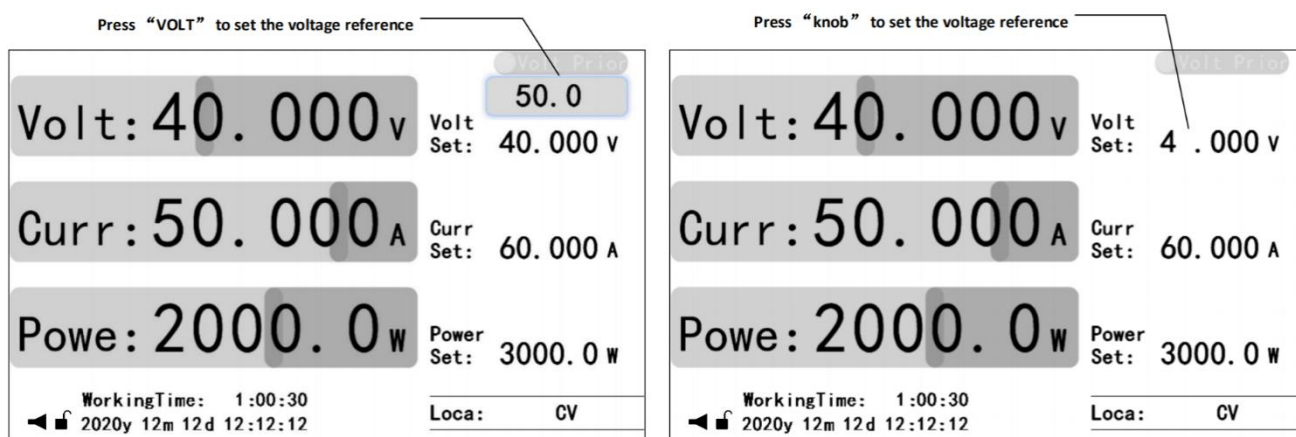

Figure 8: Reference setting

- Voltage reference setting: Press the "VOLT" key or press the "Knob" key to edit the voltage reference value, enter a valid value, and press "ENTER" or "knob" key to

- confirm;
- Current reference setting: Press the "CURR" key or press the "Knob" key twice to edit the current reference value, enter a valid value, and press "ENTER" or "knob" key to confirm;
- Power reference setting: Press "VOLT" and "CURR" key simultaneously or press "Knob" key three times to edit the power reference value, enter a valid value, and press "ENTER" or "knob" key to confirm;
- Open and close output: Press the "ON/OFF" key to open the output (The "ON/OFF" key is light), and press the "ON/OFF" key to close the output (The "ON/OFF" key is OFF);
- Voltage/current priority switching: Close the output and double-click "VOLT" or "CURR" key to switch the priority under the Home/auxiliary Home (Switch time is 1 seconds).
- SAVE Setting: 1. Under the Home, function setting UI or protection setting UI, if the Settings are valid, press "SAVE" key to save the common mode data; On the application mode setting UI, if the Settings are valid, press "SAVE" key to save the application mode data;
- Recall setting: 1. On the Home/auxiliary Home, press "RECALL" key to bring up the recall function option. Press "←↑" Or "→↓" key to select the data type and press "ENTER" key to go to the recall UI for the data type. Press "←↑" or "→↓" key to select the pre-called data and press "ENTER" key to confirm the callback data. 2. On the application mode setting UI, press "RECALL" key to bring up the relevant recall UI, press "←↑" or "→↓" key to select the pre-called data, and press "ENTER" key to confirm the callback data;
- Local/Remote mode switching: Press "L/R" to switch the local/remote mode temporarily in the Home/auxiliary Home (for temporary test, the mode is not saved);
- Buzzer control: Under the system setting UI, press "←↑" or "→↓" key to select Buzzer, and press "ENTER" key to enter buzzer control option. Select the corresponding level, and press "ENTER" key to confirm;

- Note:**
1. ***Common mode data includes voltage, current and power reference values as well as parameters of function setting and protection setting in user Settings.***
 2. ***When the key triggers the setting of reference value, the preset area will be displayed above the corresponding operated element in the setting area. Enter a preset value through the number or knob key; When the knob triggers the setting of reference value, the corresponding bit of the element to be operated in the setting area will flash. Through "←↑" Or "→↓" key to select the operation position, and then enter the preset value through the number or knob key.***
 3. ***For local/remote mode Settings, see "LCD Menu - > User Settings - > Function setting" section in 《OWP_H Series Use Manual》 for details.***

3 Appendix

3.1 Accessory

Certificate×1

Quick guide×1

1.5m input power line×1

6PIN terminal block×1

3.2 Key description

Area	Abbreviation	Description
Setting	VOLT	Voltage reference setting
	CURR	Current reference setting
	VOLT+CURR	Power reference setting
	LOCK	Lock/unlock key
	ON/OFF	Open/close output
Function	← ↑	Move the cursor one bit to the left (numeric Settings) Move up one line
	→ ↓	Move the cursor one bit to the right (numeric Settings) Move down one line
	DEL	Deletes the value of the current bit
	EXIT	Return to the previous level or exit the setting
	SAVE	Save the normal data (In normal mode) Save App data (In data mode)
	RECALL	Recall saved data on Home
	L/R	Switch local/remote mode
Figure	CONF	Enter the function UI
	0~9	Enter figure
	.	Enter decimal point "."
Knob	ENTER	Enter the menu Input confirm Switch the home and the Auxiliary home
	Clockwise	Increment the input value (numeric Settings) Move Up N line
	Anticlockwise	Decrease the input value (numeric Settings) Move Down N line

	Press	<p>Enter the menu Input confirm Under the home:</p> <ol style="list-style-type: none"> 1. Press to set voltage reference 2. Press twice to set the current reference 3. Press three times to set the power reference 4. In the reference setting state, press confirm
--	-------	---

3.3 User setting list

Scope	Name	Description	Default
Communication	Baud Rate	Baud rate setting	9600 bps
	CRC Alignment	Sending mode of CRC 16-bit check data	Little Endian
	Modbus Address	Modbus protocol address	0x01
Function	Startup Mode	The device is in local/remote control mode after power on	Local
	Rise Time Of Voltage	Rise Time Of Voltage Setting	30 ms
	Fall Time Of Voltage	Fall Time Of Voltage Setting	0 ms
	Rise Time Of Current	Rise Time Of Current Setting	30 ms
	Fall Time Of Current	Fall Time Of Current Setting	0 ms
	Auto-Reco(Fault)	After the fault occurs, disable the output and check whether the output will be automatically restored after the specified time	30 s, Close
	Auto-output(Hold)	After power-on, whether to automatically start output after the specified time	30 s, Close
	Timing output	Reference time: Use the clock or power-on time as the reference time Time range Enable: Enables or disables this time range On/Off time: set the time range	Disable
	Parallel/Series Connection	Type of connection: independent, parallel or series Master/slave: the master or slave	Independent
Dry Contact output	Control mode: Disable, local or remote control Relationship: logic related to fault, startup, condition setting, or time setting Signal delay: delay from the dry contact action after the logic is triggered	Disable	

	Dry Contact Input	Relationship: Disabled; Fault; Start or buzzer	Disable
Protection	Over-Volt Value	Over-Voltage Protection Value	105% V_{Rated}
	Time of Duration	Trigger over-voltage protection time	1000 ms
	Over-Curr Value	Over-Current Protection Value	105% I_{Rated}
	Time of Duration	Trigger over-current protection time	500 ms
	Level1 Overload Value	Level1 overload protection value	105% P_{Rated}
	Time of Duration	Trigger Level1 overload protection time	10000 ms
	Level2 Overload Value	Level2 overload protection value	110% P_{Rated}
	Time of Duration	Trigger Level2 overload protection time	5000 ms
	Level3 Overload Value	Level3 overload protection value	120% P_{Rated}
	Time of Duration	Trigger Level3 overload protection time	1000 ms
	Under-Volt Protection	Under-voltage protection switch	Disable
	Protection Value	Under-voltage protection value	10% V_{Rated}
	Protection Delay	Under-voltage protection detection delay	1000 ms
	Time Of Duration	Trigger under-voltage protection time	1500 ms
	Under-Curr Protection	Under-current protection switch	Disable
	Protection Value	Under- current protection value	10% I_{Rated}
	Protection Delay	Under- current protection detection delay	1000 ms
	Time Of Duration	Trigger under- current protection time	1500 ms
	Short-Circuit Protection	Short-circuit protection switch	Disable
	Protection Value	Short-circuit protection voltage value	5% V_{Rated}
	Protection Delay	Short-circuit protection detection delay	10 ms
Time Of Duration	Trigger Short-circuit protection time	20 ms	
Protection Switchs	Relevant protection switches	---	
Password	Password	User Default Settings	---
Reset	Factory Reset	Restoring factory Settings (except for information records)	---
	Error Log reset	Clears fault Records	---
	System Data Reset	Clears UI or all system setting	---
	User Data Reset	Clears selected data	---

3.4 Warning list

Name	Attribute	Description	Troubleshooting
Write EEPROM Err	Unrecoverable error	Write EEPROM Error	Power off, Restart.
Read EEPROM Err		Read EEPROM Error	Power off, Restart.
Write FLASH Err		Write FLASH Error	Power off, Restart.
Read FLASH Err		Read FLASH Error	Power off, Restart.

Diff Speci Err		Different from Master specifications	Power off, Restart.
External Error	Recoverable error	A fault was detected through dry contact input	Check whether dry contact signal input is normal and exclude alarm signal.
Driver Protect		Driver circuit error	Power off, Restart.
HW Over-Volt P		The hardware over-voltage circuit detects an over-voltage error	Confirm start overshoot or steady overshoot (overshoot in working process), if it is start overshoot, can set "priority" to "current priority", can also set "Rise Time Of Volt" parameter to a reasonable value(voltage priority); If it is a steady state overshoot and the voltage is not more than 1.3 times the rated voltage, you can turn off the hardware overvoltage protection function. If the voltage is more than 1.3 times the rated voltage, install an anti-reverse diode on the output side.
HW Over-Curr P		The hardware over-current circuit detects an over-current Error	Confirm start overshoot or steady overshoot (overshoot in working process), if it is start overshoot, can set "priority" to "voltage priority", can also set "Rise Time Of Volt" parameter to a reasonable value(voltage priority); If steady-state overshoot occurs, disable hardware overcurrent Protection.
Over-Volt P		The software detects an over-voltage error	Confirm start overshoot or steady overshoot (overshoot in working process), if it is start overshoot, can set priority to "voltage priority", can also set "Rise Time" parameter to a reasonable value; If the overshoot is steady state, the "over-current protection value" or "overcurrent duration" can be appropriately increased;
Over-Curr P		The software detects an over-current error	Confirm start overshoot or steady overshoot (overshoot in working process), if it is start overshoot, can set "priority" to "voltage priority", can also set "Rise Time Of Curr" parameter to a reasonable value(current priority); In the case of steady overshoot, the "overcurrent protection value" or "overcurrent duration" can be appropriately raised.

Under-Volt P		The software detects an under-voltage error	Check whether the error is reasonable. If not, reset under-voltage protection parameters.
Under-Curr P		The software detects an under-current error	Check whether the error is reasonable. If not, reset under-current protection parameters.
Short-Circuit P		The software detects an short-circuit error	Check whether the short-circuit protection occurs. If the short-circuit error occurs, rectify the short-circuit error. Otherwise, reset the short-circuit protection parameters.
Over-Load P		The software detects an overload error	Eliminate overload error or adjust overload protection parameters.
Over Temperature		The software detects an over- Temperature error	Check whether the power supply air duct is blocked.
Error Resume		Automatic error recovery is enabled, recoverable errors are detected, and recovery attempts fail for 10 times	After confirming the cause of the error and troubleshooting, restart the machine. The error alarm can be cleared by pressing the "EXIT" key on the main UI.
key is locked	Warning	Key locked	Press the "LOCK" key to unlock it.
Return to HOME		Operation method in the home	Return to the main UI and operate.
Close Output		Method of operation in closed output state	Operation after closing output.
RemoteCntr:Comms		Operate keys in remote mode	Press "L/R" to switch back to local control.
RemoteCntr:Analog			
Switching Prior		Cannot start output during priority switching	Open output later.
Please Later!		The priority cannot be switched again during priority switching	Wait 1 second and switch the priority again.
Step Mode Is En		Cannot enable other mode in step mode	Operation after Turn off Step mode.
Chg Mode Is En		Cannot enable other mode in charge mode	Turn off charging mode before operation.
Func Mode Is En		Cannot Enable other mode In function generator mode	Turn off function generator before operation.
Exit Setting		Illegal operation	Operation after exiting the Settings.

Invalid Operate		The save and call functions are unavailable in the current UI	Perform operations on the correct UI.
Value Exceeds		The input value exceeds the legal range	Input valid value.
Value Too Small			
Not Be Set To '0'		The input value cannot be '0'	Input valid value.
Password Error		Incorrect password input	Input the correct password, if you forget the password, call our company.
Unset Volt Ref		The output cannot be open without setting the voltage reference	Set the voltage reference and start the output.
Unset Curr Ref		The output cannot be open without setting the current reference	Set the current reference and start the output.
Unset Power Ref		The output cannot be open without setting the power reference	Set the power reference and start the output.
Illegal Data		Saving a data group is invalid	Save the data group after setting it correctly.
Full Data Space		128 data groups are full	Delete redundant data groups and save them.
No Dada		The precall data group is empty	Call data after saving the corresponding data group.
AddrRange :1~247		Invalid MODBUS address	Input valid address
Func Code Err	Communication error	Invalid function code	Operate according to the communication protocol;
RegisterAddrErr		Invalid register address	Operate according to the communication protocol;
Data Range Err		Illegal data	Operate according to the communication protocol;
Local Mode Err		The device is in local control mode	Switch to remote mode