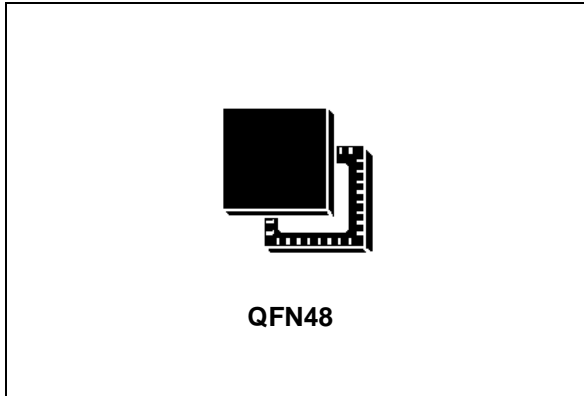

**RAIN<sup>®</sup> RFID single chip reader EPC Class1 Gen2 compatible**

Datasheet - production data

**Description**

The ST25RU3993 RAIN<sup>®</sup> (UHF) RFID reader device provides multi-protocol support for the 840-960 MHz UHF band compatible with ISO18000-62 & -63, ISO29143 and to GS1's EPC UHF Gen2 air interface protocol. It includes an on-chip VCO and a power amplifier, and offers a complete set of RFID features including dense reader mode (DRM) functionality and support for frequency-hopping, low-level transmission coding, low-level decode, data framing and CRC checking.

The ST25RU3993 operates at very low-power, making it suitable for use in portable and battery-powered equipment such as mobile phones.

Packaged in a 7x7 mm QFN, the ST25RU3993 is able to deliver very high sensitivity and provides high immunity against the effects of antenna reflection and self-jamming. This is critical in mobile and embedded applications, in which antenna design is often compromised by cost or size constraints. High sensitivity enables the end-products to achieve their required read range while using a simpler and cheaper antenna, thus reducing overall system cost.

Thanks to its high level of integration, the ST25RU3993 requires only an external 8-bit microcontroller to create a complete RFID reader system, thus eliminating the need for a complex RFID co-processor.

**Features**

- Supply voltage range 3.0 to 3.6 V
  - Limited operation possible down to 2.7 V
  - Maximum PA supply voltage 4.3 V
  - Peripheral I/O supply range 1.65 to 5.5 V
- Protocol support for:
  - ISO 18000-6C (EPC Class1 Gen2)
  - ISO 29143 (Air interface for mobile RFID)
  - ISO 18000-6A/B through direct mode
- DRM: 250 kHz and 320 kHz filters for M4 and M8
- Integrated supply regulators
- Frequency hopping support
- ASK or PR-ASK modulation
- Automatic I/Q selection
- Phase bit for tag tracking with 8-bit linear RSSI
- Temperature range: -40 °C to 85 °C
- 48-pin QFN (7x7x0.9 mm) package
- Tag read rates of up to 700\* tags/s (16-bit tag EPC length)



# Contents

<b>1</b>	<b>Description</b> .....	<b>9</b>
1.1	Block diagram .....	9
<b>2</b>	<b>Functional overview</b> .....	<b>10</b>
2.1	Power supply .....	12
2.1.1	Main regulators .....	12
2.1.2	Internal PA supply regulator .....	12
2.1.3	Periphery communication supply .....	12
2.1.4	Automatic power supply level setting .....	12
2.1.5	Power modes .....	13
2.2	Host communication .....	14
2.2.1	Writing to registers .....	16
2.2.2	Reading from registers .....	17
2.2.3	Direct commands .....	18
2.2.4	SPI interface timing .....	22
2.2.5	CLSYS output .....	24
2.2.6	IO signal level and output characteristics .....	24
2.2.7	OAD, OAD2 outputs .....	25
2.3	PLL and VCO section .....	25
2.3.1	Voltage controlled oscillator .....	26
2.3.2	PLL prescaler and main divider .....	26
2.3.3	PLL reference frequency .....	27
2.3.4	Reference frequency source .....	27
2.3.5	Phase-frequency detector and charge pump .....	27
2.3.6	Loop filter .....	27
2.3.7	Frequency hopping commands .....	27
2.3.8	PLL start-up and frequency hopping .....	28
2.4	Device status control .....	28
2.5	Protocol control .....	28
2.6	Transmission section .....	29
2.6.1	Tx data handling and coding .....	29
2.6.2	Tx shape circuitry .....	29
2.6.3	Local oscillator (LO) path .....	30
2.6.4	Modulator .....	30

2.7	Tx outputs	30
2.8	Tx operation modes	31
2.8.1	TX normal mode	31
2.8.2	TX direct mode	33
2.9	Receiver	33
2.9.1	Input mixers	34
2.9.2	Local oscillator path	35
2.9.3	Fast AC coupling	35
2.9.4	Rx filter	35
2.9.5	IQ selection	38
2.9.6	Bit decoder	39
2.9.7	Data framer	39
2.10	Data reception modes	39
2.10.1	Rx normal mode	39
2.10.2	Rx direct mode	42
2.10.3	Modes supporting tuning of antenna or directivity device	43
2.10.4	Logarithmic RSSI	43
2.11	A/D converter	43
2.11.1	External RF power detector	43
2.11.2	Reflected RF power indicator	44
2.11.3	Supply voltage measurement	44
2.11.4	Linear RSSI with sub-carrier phase bit	44
2.11.5	Internal signal level detectors	45
2.12	Interrogator anti-collision support	45
<b>3</b>	<b>Register description</b>	<b>46</b>
3.1	Main control registers	47
3.1.1	Device status control register	48
3.1.2	Protocol selection register	48
3.2	Configuration registers	49
3.2.1	Tx options register	49
3.2.2	Rx options register	49
3.2.3	TRcal high register	50
3.2.4	TRcal low register	50
3.2.5	AutoACK wait time register	51
3.2.6	Rx no response time register	51

3.2.7	Rx wait time register	52
3.2.8	Rx filter setting register	52
3.2.9	Rx mixer and gain register	53
3.2.10	Regulator and PA bias register	54
3.2.11	RF output and LO control register	55
3.2.12	Miscellaneous register 1	55
3.2.13	Miscellaneous register 2	56
3.2.14	Measurement control register	57
3.2.15	VCO control register	57
3.2.16	CP control register	58
3.2.17	Modulator control register 1	59
3.2.18	Modulator control register 2	59
3.2.19	Modulator control register 3	60
3.2.20	Modulator control register 4	61
3.2.21	PLL main register 1	61
3.2.22	PLL main register 2	62
3.2.23	PLL main register 3	63
3.2.24	PLL auxiliary register 1	63
3.2.25	PLL auxiliary register 2	64
3.2.26	PLL auxiliary register 3	64
3.2.27	Interrogator collision detection and IQ selection settings register	65
3.2.28	Emitter-coupled mixer options register	65
3.3	Status registers	66
3.3.1	Status readout page setting register	66
3.3.2	AGC and internal status display register	66
3.3.3	RSSI display register	67
3.3.4	AGL/VCO/F_CAL/PilotFreq status display register (r2Cpage[1:0] = 00)	67
3.3.5	AGL/VCO/F_CAL/PilotFreq status register (r2Cpage[1:0] = 01)	68
3.3.6	AGL/VCO/F_CAL/PilotFreq status register (r2Cpage[1:0] = 10)	68
3.3.7	ADC readout/regulator setting display register (r2Dpage[1:0] = 00)	69
3.3.8	ADC readout/regulator setting display register (r2Dpage[1:0] = 01)	69
3.3.9	Command status display register	70
3.3.10	Version register	70
3.4	Interrupt registers	71
3.4.1	Enable interrupt register 1	71
3.4.2	Enable interrupt register 2	71
3.4.3	Interrupt register 1	72

---

3.4.4	Interrupt register 2	73
3.5	Communication registers	74
3.5.1	FIFO status register	74
3.5.2	Rx length register 1	74
3.5.3	Rx length register 2	75
3.5.4	Tx setting register	75
3.5.5	Tx length register 1	76
3.5.6	Tx length register 2	76
3.5.7	FIFO I/O register	77
<b>4</b>	<b>Pinouts and pin description</b>	<b>78</b>
<b>5</b>	<b>Electrical characteristics</b>	<b>81</b>
5.1	Absolute maximum ratings	81
5.2	Operating conditions	82
5.3	Typical operating characteristics	85
<b>6</b>	<b>Package information</b>	<b>86</b>
6.1	QFN48 package information	86
<b>7</b>	<b>Part numbering</b>	<b>88</b>
<b>8</b>	<b>Revision history</b>	<b>89</b>

## List of tables

Table 1.	Power modes overview . . . . .	14
Table 2.	Serial data interface (SPI interface) signal lines . . . . .	14
Table 3.	SPI operation modes . . . . .	16
Table 4.	List of direct commands . . . . .	19
Table 5.	SPI timing parameters . . . . .	22
Table 6.	I/O pin reassignment in direct mode . . . . .	33
Table 7.	Rx filter characteristics (register 09h) . . . . .	36
Table 8.	Proposed Rx filter settings for supported link modes . . . . .	37
Table 9.	Registers map . . . . .	46
Table 10.	Device status control register . . . . .	48
Table 11.	Protocol selection register . . . . .	48
Table 12.	Tx options register . . . . .	49
Table 13.	Rx options register . . . . .	49
Table 14.	TRcal high register . . . . .	50
Table 15.	TRcal low register . . . . .	50
Table 16.	AutoACK wait time register . . . . .	51
Table 17.	Rx no response time register . . . . .	51
Table 18.	Rx wait time register . . . . .	52
Table 19.	Rx filter setting register . . . . .	52
Table 20.	Rx mixer and gain register . . . . .	53
Table 21.	Regulator and PA bias register . . . . .	54
Table 22.	RF output and LO control register . . . . .	55
Table 23.	Miscellaneous register 1 . . . . .	55
Table 24.	Miscellaneous register 2 . . . . .	56
Table 25.	Measurement control register . . . . .	57
Table 26.	VCO control register . . . . .	57
Table 27.	CP control register . . . . .	58
Table 28.	Modulator control register 1 . . . . .	59
Table 29.	Modulator control register 2 . . . . .	60
Table 30.	Modulator control register 3 . . . . .	60
Table 31.	Modulator control register 4 . . . . .	61
Table 32.	PLL main register 1 . . . . .	61
Table 33.	PLL main register 2 . . . . .	62
Table 34.	PLL main register 3 . . . . .	63
Table 35.	PLL auxiliary register 1 . . . . .	63
Table 36.	PLL auxiliary register 2 . . . . .	64
Table 37.	PLL auxiliary register 3 . . . . .	64
Table 38.	Interrogator collision detection and IQ selection settings register . . . . .	65
Table 39.	Emitter-coupled mixer options register . . . . .	65
Table 40.	Status readout page setting register . . . . .	66
Table 41.	AGC and internal status display register . . . . .	66
Table 42.	RSSI display register . . . . .	67
Table 43.	AGL/VCO/F_CAL/PilotFreq status display register (r2Cpage[1:0] = 00) . . . . .	67
Table 44.	AGL/VCO/F_CAL/PilotFreq status register (r2Cpage[1:0] = 01) . . . . .	68
Table 45.	AGL/VCO/F_CAL/PilotFreq status register (r2Cpage[1:0] = 10) . . . . .	68
Table 46.	ADC readout/regulator setting display register (r2Dpage[1:0] = 00) . . . . .	69
Table 47.	ADC readout/regulator setting display register (r2Dpage[1:0] = 01) . . . . .	69
Table 48.	Command status display register . . . . .	70

Table 49.	Version register . . . . .	70
Table 50.	Enable interrupt register 1 . . . . .	71
Table 51.	Enable interrupt register 2 . . . . .	71
Table 52.	Interrupt register 1 . . . . .	72
Table 53.	Interrupt register 2 . . . . .	73
Table 54.	FIFO status register . . . . .	74
Table 55.	Rx length register 1 . . . . .	74
Table 56.	Rx length register 2 . . . . .	75
Table 57.	Tx setting register . . . . .	75
Table 58.	Tx length register 1 . . . . .	76
Table 59.	Tx length register 2 . . . . .	76
Table 60.	FIFO I/O register . . . . .	77
Table 61.	ST25RU3993 pin definitions . . . . .	78
Table 62.	Electrical parameters . . . . .	81
Table 63.	Electrostatic discharge . . . . .	81
Table 64.	Continuous power dissipation . . . . .	81
Table 65.	Temperature ranges and storage conditions . . . . .	82
Table 66.	Operating conditions . . . . .	82
Table 67.	Differential mixer . . . . .	83
Table 68.	Single-ended mixer . . . . .	84
Table 69.	CMOS Input (valid for all CMOS inputs) . . . . .	84
Table 70.	CMOS output (valid for all CMOS outputs) . . . . .	85
Table 71.	Typical operating characteristics . . . . .	85
Table 72.	QFN48, 7x7 mm, 0.5 mm pitch, package mechanical data . . . . .	87
Table 73.	Package codification . . . . .	87
Table 74.	Ordering information scheme . . . . .	88
Table 75.	Document revision history . . . . .	89

## List of figures

Figure 1.	ST25RU3993 block diagram. . . . .	9
Figure 2.	Basic UHF reader system. . . . .	10
Figure 3.	Possible SPI configurations . . . . .	15
Figure 4.	Writing a single byte . . . . .	16
Figure 5.	Writing registers using address auto-incrementing. . . . .	17
Figure 6.	Reading a single byte . . . . .	17
Figure 7.	Reading from registers using address auto-incrementing . . . . .	18
Figure 8.	Sending direct commands . . . . .	22
Figure 9.	SPI Write timing . . . . .	23
Figure 10.	SPI Read timing . . . . .	24
Figure 11.	PLL and VCO section . . . . .	25
Figure 12.	Transmission section . . . . .	29
Figure 13.	Receiver section . . . . .	34
Figure 14.	ST25RU3993 pinout . . . . .	78
Figure 15.	QFN48, 7x7 mm, 0.5 mm pitch, package outline . . . . .	86



# 1 Description

The ST25RU3993 device is ideally suited for:

- Embedded consumer/industrial applications with cost constraints such as beverage dispensing
- Hand-held readers
- Mobile UHF RFID readers
- Battery-powered stationary readers

## 1.1 Block diagram

The block diagram is shown in [Figure 1](#).

Figure 1. ST25RU3993 block diagram

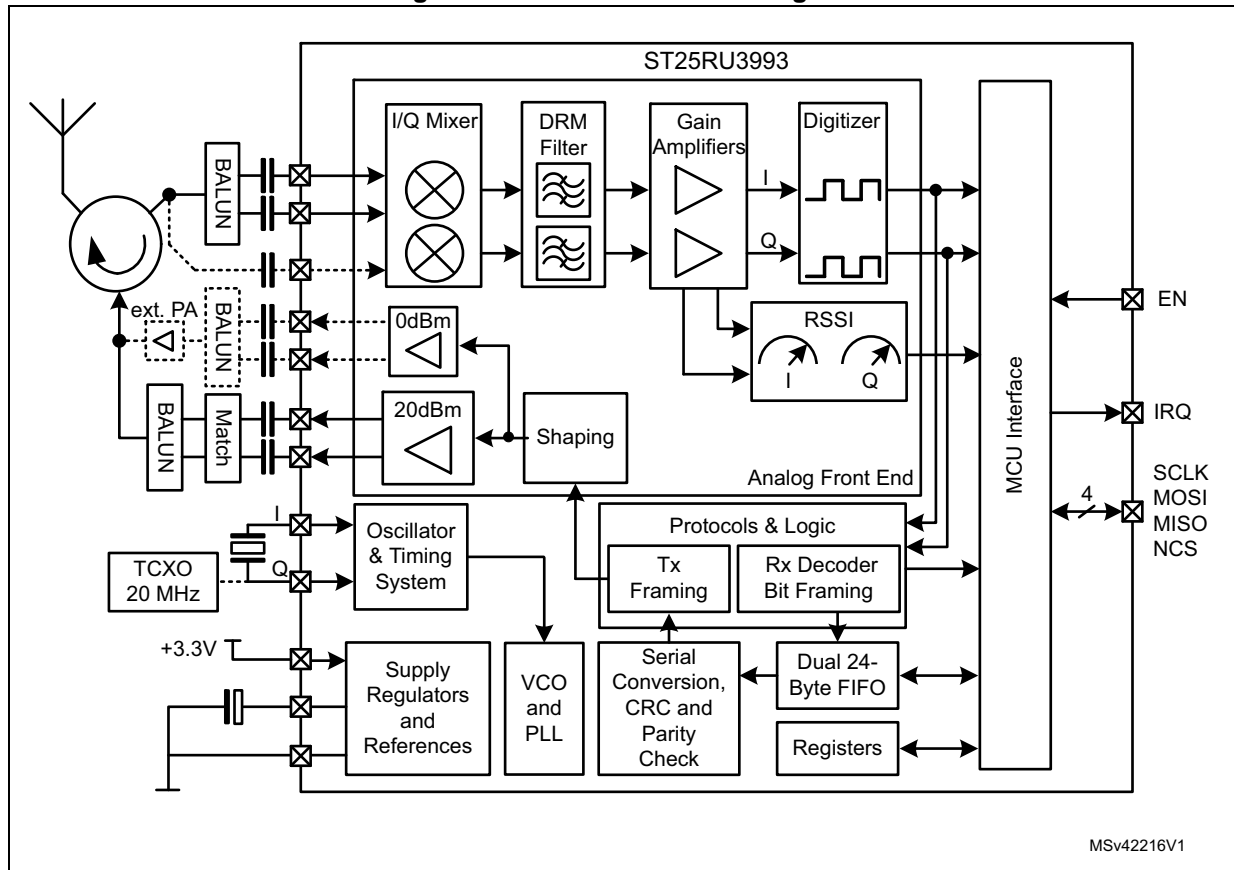

## 2 Functional overview

The ST25RU3993 UHF reader device is an integrated analog front end and protocol handling system for UHF RFID readers. The chip works on 3.3 V supply voltage and is therefore perfectly suited for low voltage, low-power applications.

It supports operation on DRM link frequencies used in ETSI and FCC regions (see [Section 2.9.4: Rx filter](#) for supported link modes). It complies with EPC Class1 Gen2 protocol (ISO 18000-6C) in normal mode and ISO 18000-6A/B in direct mode.

**Figure 2. Basic UHF reader system**

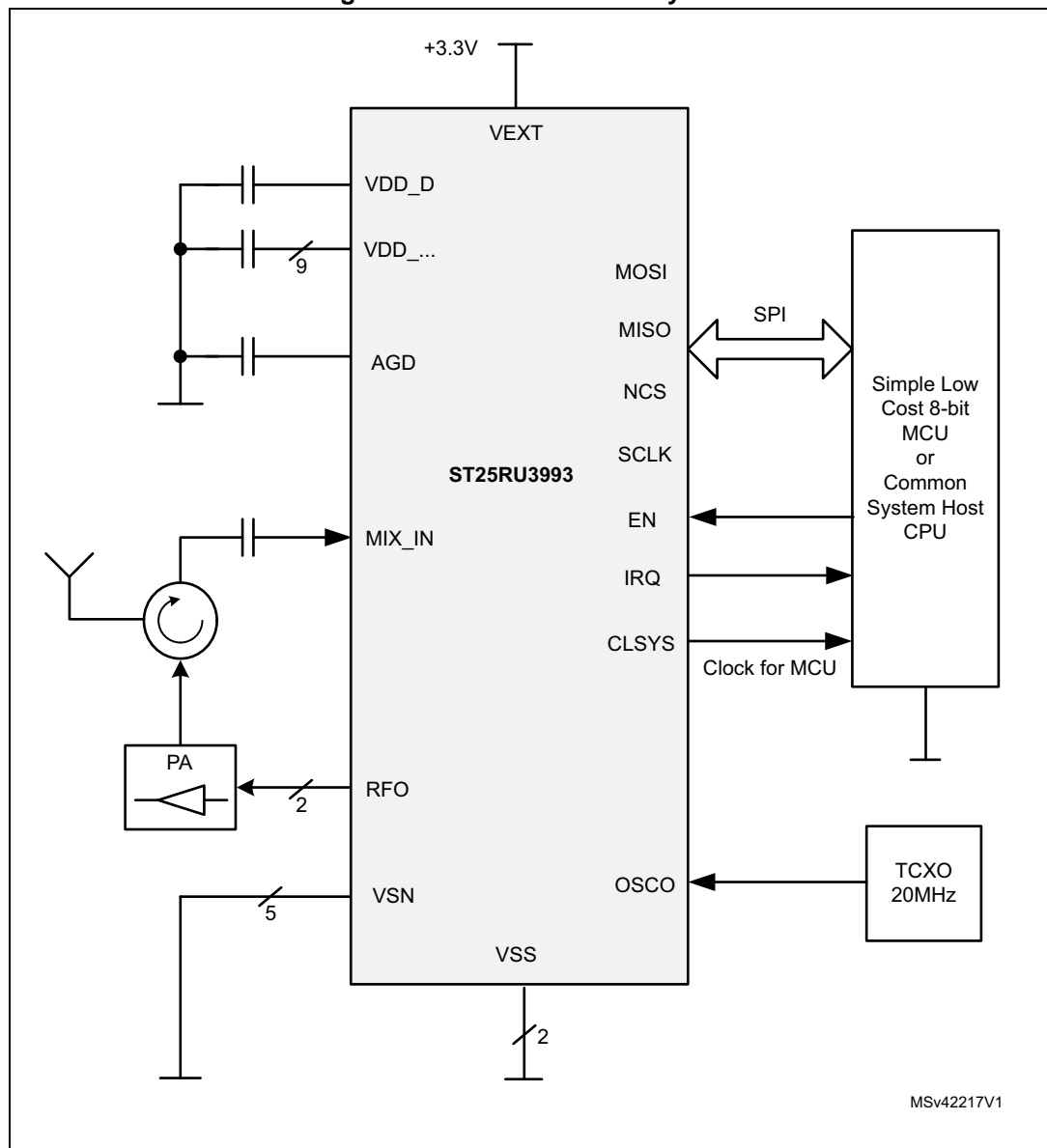

The RFID reader device features complete analog and digital functionality for the reader operation, including transmitter and receiver section with full EPC Class1 Gen2 (ISO18000-6C) digital protocol support.

The reader is enabled by setting the EN pin of the device to a positive logic level. A four-wire serial peripheral interface (SPI) is used for communication between the host system (MCU) and the reader device. The MCU is notified to service an IRQ by a logic high level on the IRQ pin. The device configuration and fine tuning of the reader performance is achieved through direct access to all control registers. The baseband data is transferred via a dual 24-byte FIFO buffer register to and from the reader device. The transmission system comprises a parallel/serial data conversion, low level data encoding and automatic generation of FrameSync, Preamble, and cyclic redundancy check (CRC).

Two transmitter output ports are available:

- One differential low-power, high linearity 0 dBm output that drives its power into a single ended 50  $\Omega$  load.
- One differential high power output that is amplified by the internal PA. The high power output delivers up to 20 dBm and requires a single ended 50  $\Omega$  load.

Both outputs are capable of amplitude shift keying (ASK) or phase reversal amplitude shift keying (PR-ASK) shaped modulation. The integrated supply voltage regulators ensure supply ripple rejection of the complete reader system.

The receiver system ensures both AM and PM demodulation, and comprises a proprietary automatic gain control system.

Selectable gain stages and signal bandwidth cover a wide range of input link frequencies and bit rate options. The signal strength of AM and PM modulation is measured and can be accessed through the [RSSI display register](#) (2Bh). The receiver output is selectable between digitized sub-carrier signals and internal sub-carrier decoder output. The internal decoder output delivers a bit stream and a data clock.

The receiver system comprises a framing system for the baseband data. It performs a CRC check and organizes the data in bytes that are then accessible to the host system through a 24-byte FIFO register.

To minimize the bill of materials (BOM), it also comprises an on-board PLL section with an integrated voltage controlled oscillator (VCO), partially integrated loop filter, supply section, ADC section and host interface section. To cover a wide range of applications the reader device has several possible configurations. The register section configures the operation and the behavior of all blocks.

The device needs to be supplied via VEXT and VEXT\_PA pins. The power supply connection is described in [Power supply](#). At device power-up, the configuration registers are preset with their default values. The default values are described in the configuration register tables along with all option bits. The communication between the reader device and the transponder(s) follows the reader-talk-first method. After device power-up and register configuration, the host system (MCU) can start a communication with the transponder by turning the RF field ON and transmitting the first protocol command. Transmission and reception is possible in two modes:

- Normal mode
- Direct mode

In normal mode the base band data is transferred through the double FIFO buffer and all protocol data processing is done internally. In the direct mode the encoders and decoders are bypassed for transmission and reception and the data processing must be done by the MCU. In the direct mode the MCU can service the analog front-end in real time.

## 2.1 Power supply

The device has its own power supply system to minimize the influence of external power supply noise and interferences and improves decoupling between different internal building blocks.

The positive supply pins are VEXT and VEXT\_PA. The negative supply pins are all VSN and VSS pins, including the exposed die pad. For optimal power supply rejection and device performance the supply voltage should be at least 3.3 V. A power supply voltage above 3.0 V enables operation with reduced power supply rejection. With lower supply voltages (down to 2.7 V) reduced device performance should be expected.

### 2.1.1 Main regulators

A set of adjustable regulators is used to supply the different internal building blocks of the device. The common input pin for most regulators is VEXT. The regulator outputs are the VDD\_A, VDD\_LF, VDD\_D, VDD\_MIX and VDD\_B pins. Each regulator output requires shunt capacitors to ground. Typical values are 2.2  $\mu$ F and 100 pF, ceramic capacitors of (at least) X5R class are recommended. VDD\_LFI and VDD\_TXPAB are supply input pins and should be connected to VDD\_MIX.

The regulated output voltage can be set in the range from 2.7 V up to 3.4 V in 0.1 V steps using option bits rvs[2:0] in the [Regulator and PA bias register](#) (0Bh). It is also possible to adjust the regulated output voltage automatically to approximately 300 mV below the supply voltage V<sub>EXT</sub> using the direct command automatic power supply level setting (A2h).

### 2.1.2 Internal PA supply regulator

The internal power amplifier has a dedicated voltage regulator. The input pin is VEXT\_PA, output is VDD\_PA. The regulator has an internal compensation circuit that requires a small external capacitance on VDD\_PA (typical 1 nF). Operation of this voltage regulator is allowed only in a loaded condition.

The regulated output voltage can be set in the range from 2.7 V up to 3.4 V in 0.1 V steps using option bits rvs\_rf[2:0] in the [Regulator and PA bias register](#) (0Bh). It is also possible to adjust the regulated output voltage automatically to approximately 300 mV below the supply voltage V<sub>EXT</sub> using the direct command automatic power supply level setting (A2h).

As the rvs\_rf[2:0] settings and the automatic power supply level adjustment generally can have different values, the system is designed to automatically select the lowest voltage level for the VDD\_PA.

### 2.1.3 Periphery communication supply

The logic levels used for communication with the host system (MCU) can vary within a wide voltage range. The VDD\_IO input pin is used to define these logic levels between 1.65 V and 5.5 V. It is recommended to connect VDD\_IO to the host system power supply in order to avoid any voltage mismatch.

### 2.1.4 Automatic power supply level setting

The power supply section comprises a system that automatically adjusts the regulators to approximately 300 mV below the V<sub>EXT</sub> supply voltage, required to achieve good power supply rejection in the regulators.

The direct command automatic power supply level setting (A2h) activates the system. To switch back to manual power supply level adjustment, the direct command manual power supply level setting (A3h) should be sent.

Before the direct command (A2h) is issued it is necessary to set and lock the PLL within the allowed target frequency (840 MHz to 960 MHz).

At the beginning of the automatic adjustment, the device sets the regulators to 3.4 V and enables the RF field to simulate a normal power supply load. During the procedure the device decreases the regulated voltage in 100 mV steps, each 300  $\mu$ s long. The lowest voltage that the regulator can set is 2.7 V.

The procedure stops when the difference between the  $V_{EXT}$  and the regulated voltages is at least 300 mV, or reaches the last step. The device then disables the RF field and sends an IRQ request with Irq\_cmd bit (register 36h) set to high.

### 2.1.5 Power modes

The device has four main power modes:

- Power down mode
- Standby mode
- Normal mode – RF OFF
- Normal mode – RF ON

#### Power down mode

By driving the EN pin to a logic low level the device enters the power-down mode. In this mode, the circuit is disabled.

#### Standby mode

The standby mode is entered from normal mode by setting the option bit stby high (register 00h). In the standby mode the voltage regulators, the reference voltage system and the crystal oscillator are operating in a low-power mode. The PLL, transmitter output stages and the receivers are switched off. All register settings are maintained while switching between standby and normal mode. The bias and reference voltages after stby = 0 typically stabilize within 12 ms. By then the device is ready to switch ON the RF field and start data transmission.

#### Normal mode - RF OFF

Setting the EN pin to a logic high level activates the normal mode. In this mode the following internal blocks are enabled:

- All supply regulators
- Reference voltage and bias system
- Crystal oscillator
- RF oscillator and PLL

When the EN pin is set to a logic high level the bias and reference voltages become stable after 12 ms (typical value). From then on the device is ready for interaction with the internal registers. After the reference frequency source stabilizes and the CLSYS clock becomes active, the device is ready to operate according to the configuration of its internal registers. If the crystal oscillator is used, the time the crystal stabilizes depends on the crystal type used. A typical time is 1.5 ms to 3 ms. By reading the [AGC and internal status display](#)

*register* (2Ah), the MCU can check the crystal status. The status bit `osc_ok = 1` in this register indicates that the crystal oscillation is stable and that the device is ready to operate.

If a continuously running TCXO is used the settling of the internal clock is faster, as only the OSCO pin DC level needs to be set. The same test with the `osc_ok` status bit as described above can be used.

After additional 500 ms (typ.) the device is ready to switch on the RF field and the transmission of inventory commands for transponder communication.

**Normal mode - RF ON**

By setting the `rf_on` option bit in the *Device status control register* (00h) the device immediately starts with the field ramp-up. The ramp-up time and shape are defined by `trfon[1:0]` and `lin_mod` option bits in the *Modulator control register 3* (15h). When the RF field ramp-up is finished the `rf_ok` status bit (register 2Ah) is set to high. In addition an IRQ is generated, which is indicated by `Irq_ana` status bit set to high (register 38h).

Setting the option bit `rf_on` to low starts the field ramp-down. The RF field is decreased according to `trfon[1:0]` and `lin_mod` bits (register 15h). When this step is completed, the `rf_ok` status bit in *AGC and internal status display register* (2Ah) is set to low, and an IRQ is sent with the `Irq_ana` status bit high.

*Table 1* summarizes the available power modes and the transitions times between them.

**Table 1. Power modes overview**

Mode	EN pin	Stby option bit	rf_on option bit	Current consumption	Time to enter the mode	Time from mode to active RF field
Power down	L	-	-	1 µA	Immediately from normal mode	12 - 17 ms (Crystal or TCXO start + bias start)
Standby	H	H	L	3 mA	Immediately from normal mode	12 - 17 ms (Crystal or TCXO start + bias start)
Normal	H	L	L	24 mA	12 - 17 ms (Crystal or TCXO start + bias start)	12.5 µs (Field ramp-up)
Normal with RF field on	H	L	H	75 mA	12.5 µs (Field ramp-up)	NA

**2.2 Host communication**

A standard 4-wire serial interface (SPI) together with an interrupt request line (IRQ pin) is used to communicate with the device. An additional line (CLSYS) can be used as a system clock source for the MCU.

**Table 2. Serial data interface (SPI interface) signal lines**

Name	Signal	Signal level	Description
NCS	Digital input	CMOS	SPI enable (active low)
SCLK	Digital input	CMOS	Serial clock
MOSI	Digital input	CMOS	Serial data input



**Table 2. Serial data interface (SPI interface) signal lines (continued)**

Name	Signal	Signal level	Description
MISO	Digital output with tri-state	CMOS	Serial data output
IRQ	Digital output	CMOS	Interrupt request output
CLSYS	Digital output	CMOS	MCU clock output

By setting the NCS pin low the SPI interface is enabled. While NCS is high the SPI interface is deactivated. It is recommended to keep signal NCS high whenever the SPI interface is not used. MOSI is sampled at the falling edge of SCLK. The SPI communication is done in bytes. The first two bits of the first byte on the MOSI line (after NCS high-to-low) define the SPI operation mode. MSB bit is always transmitted first (valid for address and data).

The read and write modes support address auto incrementing for multi byte transfers. Only the first address needs to be sent and internally the address is incremented for consecutive reads or writes.

The MISO output is usually in tri-state and it is only driven when output data are available. This allows to short-circuit the MOSI and the MISO lines externally to create a bi-directional signal (see [Figure 3](#)).

During the time the MISO output is in high impedance it is possible to activate a 50 kΩ pull-down resistor by setting option bits `miso_pd1` and `miso_pd2` in [Miscellaneous register 1](#) (0Dh).

[Figure 3](#) shows the possible SPI interconnection options.

**Figure 3. Possible SPI configurations**

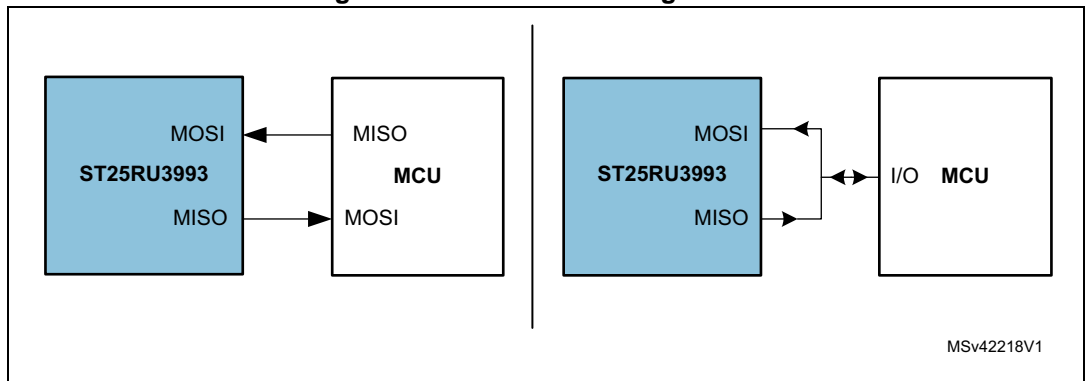

Table 3. SPI operation modes

Command type	Mode pattern (MSB to LSB)								Mode related data
	Mode		Register address / command ID						
	M1	M0	X5	X4	X3	X2	X1	X0	
Write	0	0	A5	A4	A3	A2	A1	A0	Data byte (or more bytes if of autoincrementing)
Read	0	1	A5	A4	A3	A2	A1	A0	Data byte (or more bytes if of autoincrementing)
Direct command	1	0	C5	C4	C3	C2	C1	C0	-
RFU	1	1	x	x	x	x	x	x	-

### 2.2.1 Writing to registers

Figure 4 show typical SPI Write communication examples for a single byte and for multiple bytes using address auto-incrementing. Following the SPI operation mode bits (M1 and M2) the address bits (A5: A1) of the target register are sent. Then one or more data bytes are sent depending on using auto-incrementing or not. The communication is terminated by putting NCS back to high. If this happens before a packet of 8 bits (one byte) is sent, writing to this register is not performed. If the register at the defined address does not exist or is a read only register the write command does not succeed either.

Figure 4 shows an example of a SPI write command signaling for a single byte.

Figure 4. Writing a single byte

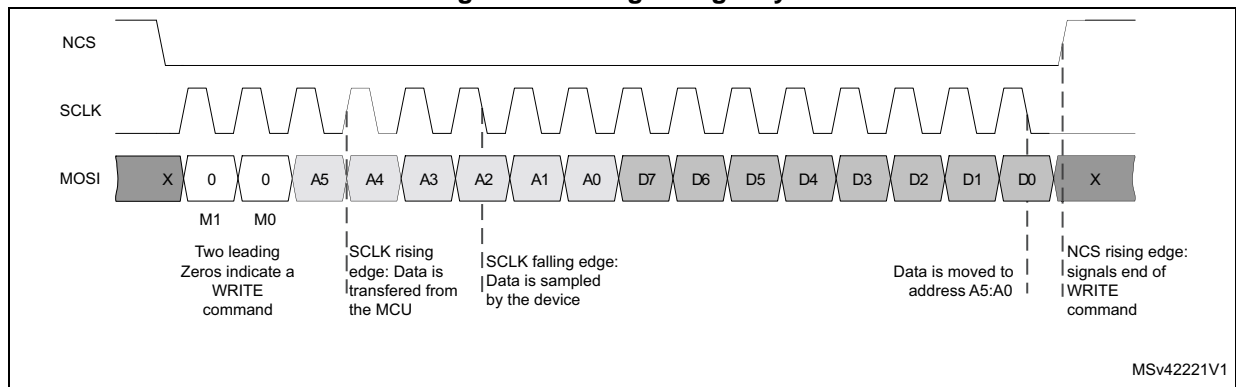
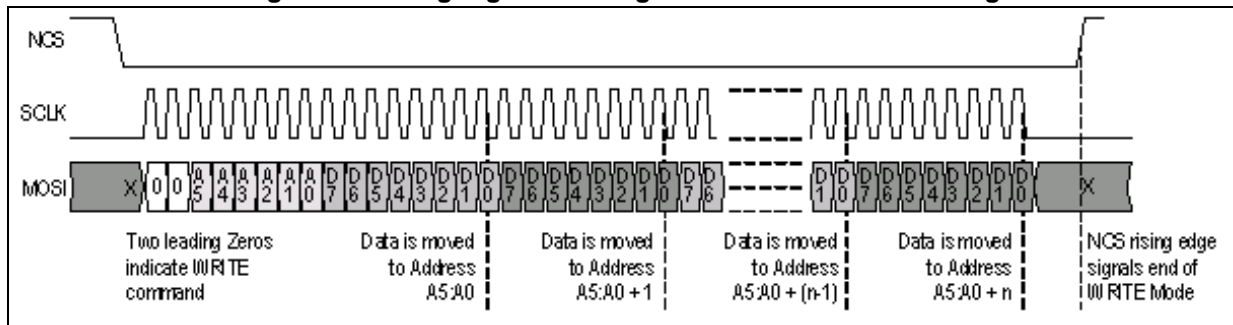



Figure 5 an example of a SPI write command signaling for multiple bytes.

Figure 5. Writing registers using address auto-incrementing



### 2.2.2 Reading from registers

After the SPI operation mode bits (M1 and M0) the target address is sent. Then one or more data bytes are transferred to the MISO output. MOSI is sampled at the falling edge of SCLK. Data to be read from the internal registers are transferred to the MISO pin on rising edge of SCLK and should be sampled by the MCU on the falling edge. If the register address does not exist all 0 data are sent to MISO.

Figure 6 shows an example for a typical SPI Read command for a single byte.

Figure 6. Reading a single byte

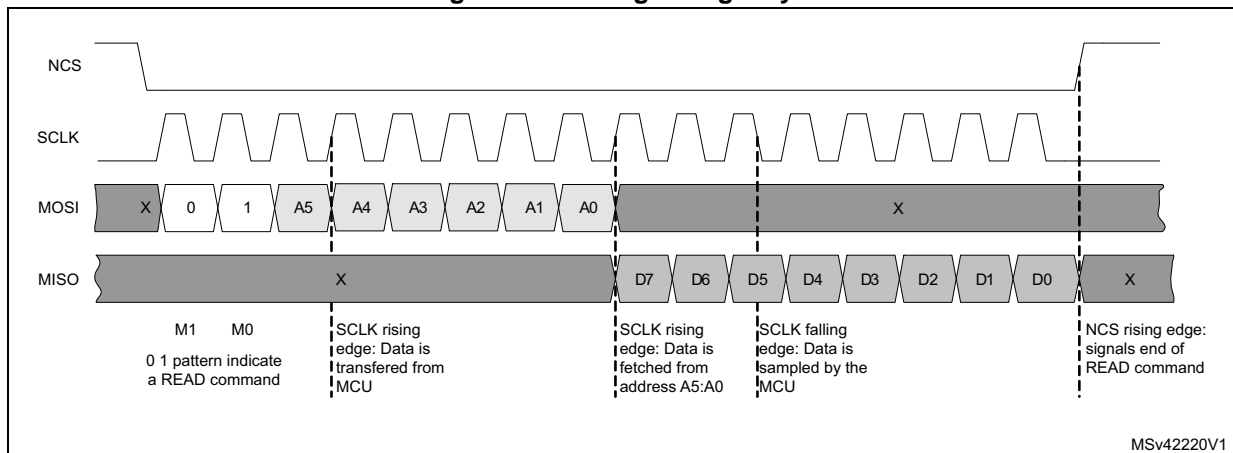

MSv42220V1

Figure 7 shows an example of an SPI read command signaling for multiple bytes.

Figure 7. Reading from registers using address auto-incrementing

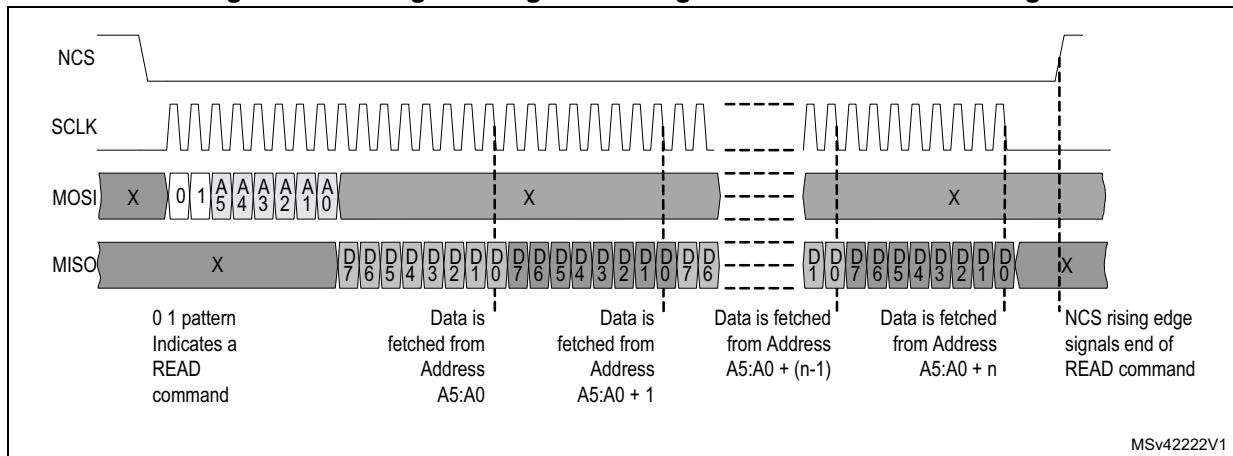

### 2.2.3 Direct commands

Direct commands have no parameters, so only a single byte needs to be sent. The only exception is the Query command, which requires two parameter bytes (stored in FIFO) following the command byte. SPI operation mode bits M1 = 1 and M0 = 0 define a direct command. The following six bits define the direct command ID. The direct command is executed at the last falling edge of SCLK. Some direct commands are executed immediately while others start a process with certain duration (calibration, measurements...).

**Caution:** During execution of such commands it is not recommended to start another activity on the SPI interface.

After the execution of a direct command an IRQ request with Irq\_cmd bit high (register 38h) is sent.

Table 4. List of direct commands

Code (HEX)	Command	Direct execution
80h	Idle	Yes
81h	Direct Mode	Yes
83h	Soft Init	Yes
84h	Hop to Main Frequency	Yes
85h	Hop to Auxiliary Frequency	Yes
87h	Trigger AD Conversion	No
88h	Trigger Rx Filter Calibration	No
89h	Decrease Rx Filter Calibration Data	Yes
8Ah	Increase Rx Filter Calibration Data	Yes
90h	Transmission with CRC	Yes
91h	Transmission with CRC Expecting Header Bit	Yes
92h	Transmission without CRC	Yes
96h	Block Rx	Yes
97h	Enable Rx	Yes
98h	Query	Yes
99h	QueryRep	Yes
9Ah	QueryAdjustUp	Yes
9Bh	QueryAdjustNic	Yes
9Ch	QueryAdjustDown	Yes
9Dh	ACK	Yes
9Fh	ReqRN	Yes
A2h	Automatic power supply level setting	No
A3h	Manual power supply level setting	Yes
A4h	Automatic VCO range selection	No
A5h	Manual VCO range selection	Yes
A6h	AGL On	Yes
A7h	AGL Off	Yes
A8h	Store RSSI	Yes
A9h	Clear RSSI	Yes
AAh	Interrogator anti-collision support enable	Yes
ABh	Interrogator anti-collision support disable	Yes

### Direct command description

The direct commands supported by the ST25RU3993 are detailed below. Values in parentheses show the related command byte.

- **Direct mode** (81h): device enters the direct mode.
- **Soft init** (83h): this command resets the configuration registers to their default values and terminates all functions that were triggered before.
- **Hop to main frequency** (84h): this command forces the PLL to use the frequency defined in the PLL Main Registers 1 - 3. The PLL main registers are used per default.
- **Hop to auxiliary frequency** (85h): This command forces the PLL to use the frequency setting defined in the [PLL auxiliary register 1](#), [PLL auxiliary register 2](#) and [PLL auxiliary register 3](#).
- **Trigger A/D conversion** (87h): this command triggers the analog to digital conversion using the internal 8-bit A/D converter. For further information, refer to the A/D Converter description.
- **Trigger Rx filter calibration** (88h): this command triggers the Rx filter calibration procedure. For further information, refer to the Rx filter calibration description.
- **Decrease Rx filter calibration data** (89h), **Increase Rx filter calibration data** (8Ah): these commands adjust the automatically acquired Rx filter calibration data. For further information, refer to the Rx filter calibration description.
- **Transmission with CRC** (90h): transmission commands are used to transmit data from the reader to transponders. First, the Tx length registers (3Dh, 3Eh) need to be set with the number of complete bytes for transmission, including the number of bits for the incomplete byte. Then transmission data can be loaded in the FIFO register (3Fh). Transmission starts when the first byte is loaded. CRC-16 is included in the transmitted sequence.  
The optimal way to load all transmission data is to use the Continuous Write mode, starting with the address 3Dh.  
Example Using Address Auto-Incrementing:  
SPI data (MOSI): 90h - 3Dh - 00h - 30h - AAh - BBh - CCh operates as follows:
  - 90h:Transmission with CRC
  - Write 00h to 3Dh
  - Write 30h to 3Eh (three bytes are going to be transmitted)
  - Write AAh, BBh, CCh to address 3Fh (FIFO data which will be transmitted).
- **Transmission with CRC expecting header bit** (91h): same as the previous command, but it also informs Rx decoding logic that an header bit is expected in the response.
- **Transmission without CRC** (92h): same as direct command 'Transmission with CRC', but the CRC part is omitted.
- **Block Rx** (96h): the Block Rx command deactivates the digital part of receiver (bit decoder and framer). Turning OFF the receiver is useful if the system operates in a noisy environment, causing a constant switching of the sub-carrier input of the Rx digital part. The active receiver will try to detect a Preamble and if the noise pattern matches the expected signal pattern, an interrupt is generated. A constant flow of interrupt requests can be a problem for the MCU, Such situation can be avoided by deactivating the receive decoder using the block RX command. The receiver is automatically reactivated at the end of any data transmission after the Rx wait time elapses. To set the Rx wait time refer to the [Rx wait timer](#) section. A second possibility to stop block Rx is to send the enable Rx (97h) command.
- **Enable Rx** (97h): this command prepares analog and digital part of the receiver for reception. This command should be sent to trigger the reception manually. This

command should not be sent if reception is automatically triggered by a data transmission command.

- **Query (98h):** the Query command issues the EPC query, which starts the inventory round. The Query command requires additional two data bytes which should be written to the FIFO (3Fh):  
The two bytes in the FIFO should contain: "00", DR, M, TRext, Sel, Session, Target, Q  
Since this adds-up to 15 applicable bits, the LSB bit is disregarded.  
The transmitter in the end sends:
  - Preamble
  - Command ID
  - Tx data (two bytes from FIFO)
  - CRC-5.

The received RN16 is stored in the internal RN16 register for further communication steps (ACK, ReqRN). RN16 is also stored in the FIFO.

- **QueryRep (99h):** the QueryRep command issues the EPC Gen2 QueryRep command followed by two session bits. The session bits are taken from [Tx setting register \(3Ch\)](#). The received RN16 is stored in the internal RN16 register for further communications (ACK, ReqRN). RN16 is also accessible in the FIFO.
- **QueryAdjustUp (9Ah):** the QueryAdjustUp direct command issues the EPC Gen2 QueryAdjust command followed by two session bits and 'up' parameter (increasing the number of available slots). The session bits are taken from [Tx setting register \(3Ch\)](#). The received RN16 is stored in the internal RN16 register for further communications (ACK, ReqRN). RN16 is also accessible in the FIFO.
- **QueryAdjustNic (9Bh):** the QueryAdjustNic command issues the EPC Gen2 QueryAdjust command followed by two session bits and 'no change' parameter. The session bits are taken from [Tx setting register \(3Ch\)](#). The received RN16 is stored in the internal RN16 register for further communications (ACK, ReqRN). RN16 is also accessible in the FIFO.
- **QueryAdjustDown (9Ch):** the QueryAdjustUp command issues the EPC Gen2 QueryAdjust followed by two session bits and 'down' parameter (decreasing the number of available slots). The session bits are taken from [Tx setting register \(3Ch\)](#). The received RN16 is stored in the internal RN16 register for further communications (ACK, ReqRN). RN16 is also accessible in the FIFO.
- **ACK (9Dh):** the ACK command issues the EPC ACK followed by RN16 stored in the internal RN16 register during last successful Query command.
- **NAK (9Eh):** the NAK command issues the EPC Gen2 NAK command to tags.
- **ReqRN (9Fh):** the ReqRN command issues the EPC Request RN to the tag. The last received RN is used as a parameter and the received new RN16 (handle) is stored in the internal RN16 register for further communications (ACK, ReqRN). New RN16 is also stored in the FIFO.
- **Automatic power supply level setting (A2h), manual power supply level setting (A3h):** these commands trigger the automatic adjustment of the on-board voltage regulators, and switch back to the manual selection. See Periphery Communication Supply description for more details.
- **Automatic VCO range selection (A4h), manual VCO range selection (A5h):** these commands trigger the automatic VCO range selection and switch back to manual VCO range selection. See PLL and VCO description for more details.

- **AGL on (A6h), AGL off (A7h):** these commands trigger and disable the AGL action. See AGL description for more details.
- **Store RSSI (A8h), Clear RSSI (A9h):** these commands store and clear the received signal strength indicator (RSSI) data that can be used for IQ decision circuitry. See IQ Selection description for more details.
- **Interrogator anti-collision support enable (AAh), interrogator anti-collision support disable (ABh):** these commands enable or disable the interrogator anti-collision support defined in ISO 29143.

**Direct command chaining**

Direct commands with immediate execution can be followed by another SPI commands like Read or Write without deactivating the NCS signal in between.

**Figure 8. Sending direct commands**

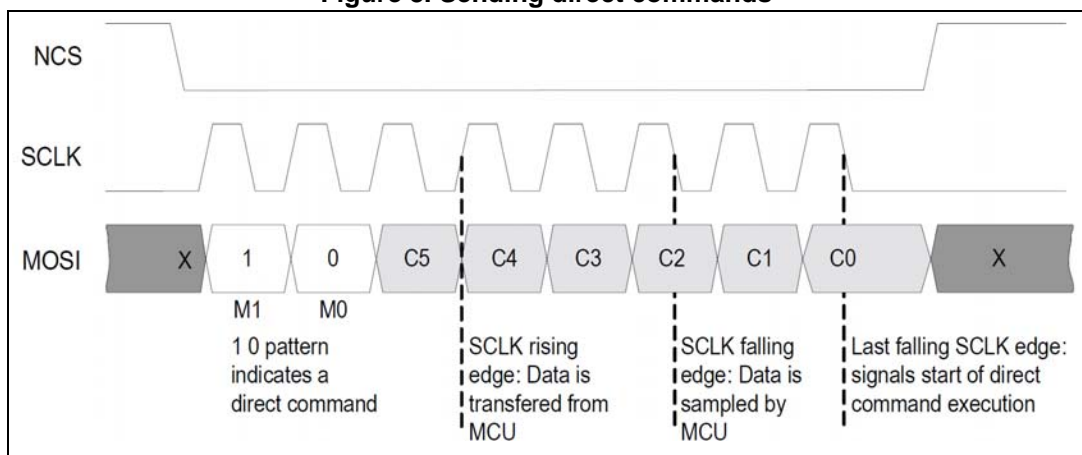

**2.2.4 SPI interface timing**

**Table 5. SPI timing parameters**

Symbol	Parameter	Note/Condition	Min	Typ	Max	Unit
General (VDD_IO > 3 V, CLOAD < 50 pF, hs_output = 1)						
BR <sub>SPI</sub>	Bit rate	-	-	-	5	Mbps
t <sub>SCLKH</sub>	Clock high time	-	70	-	-	ns
t <sub>SCLKL</sub>	Clock low time	-	70	-	-	ns
t <sub>NCSL</sub>	NCS setup time	Time between NCS high-low transition to first SCLK high transition	10	-	-	ns
t <sub>DIS</sub>	Data-in setup time	-	10	-	-	ns
t <sub>DIH</sub>	Data-in hold time	-	10	-	-	ns

**Table 5. SPI timing parameters (continued)**

Symbol	Parameter	Note/Condition	Min	Typ	Max	Unit
$t_{NCSH}$	NCS hold time Read / Write	Time between last SCLK falling edge and NCS low-high transition after a Read or Write	10	-	-	ns
$t_{NCSH}$	NCS hold time direct command	Time between last SCLK falling edge and NCS low-high transition after a direct command	70	-	-	ns
Read timing						
$t_{DOD}$	Data out delay	$V_{DD\_IO} \geq 3\text{ V}$ , $C_{LOAD} = 50\text{ pF}$ , $hs\_output = 1$	-	30	-	ns
$t_{DOD}$	Data out delay	$V_{DD\_IO} \geq 1.65\text{ V}$ , $C_{LOAD} = 50\text{ pF}$ , $hs\_output = 1$	-	60	-	ns
$t_{DOD}$	Data out delay	$V_{DD\_IO} \geq 3\text{ V}$ , $C_{LOAD} = 50\text{ pF}$ , $hs\_output = 0$	-	90	-	ns
$t_{DOHZ}$	Data out to high impedance delay	Time for the SPI to release the MISO line	-	40	-	ns

Figure 9 shows the corresponding timing waveforms and parameters for the SPI write command.

**Figure 9. SPI Write timing**

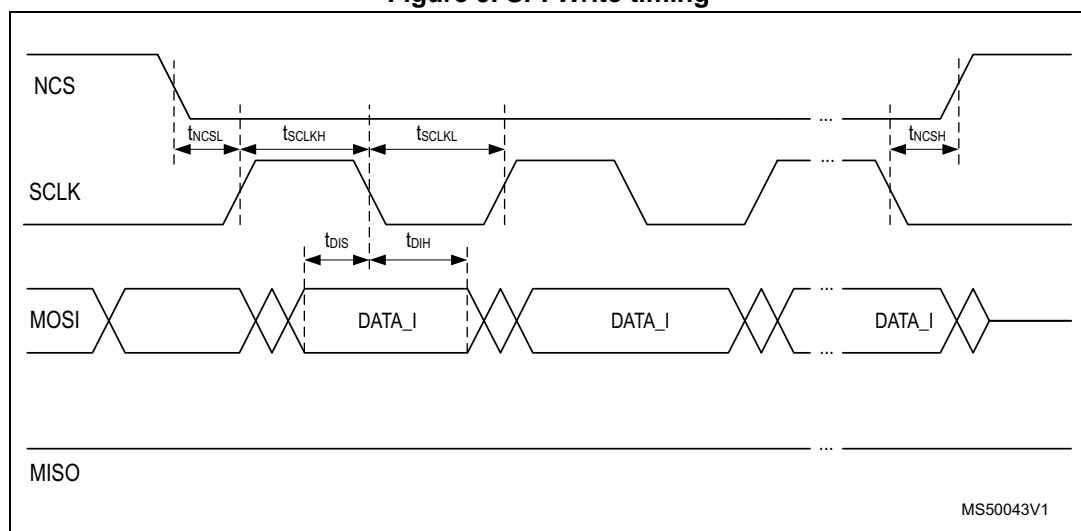
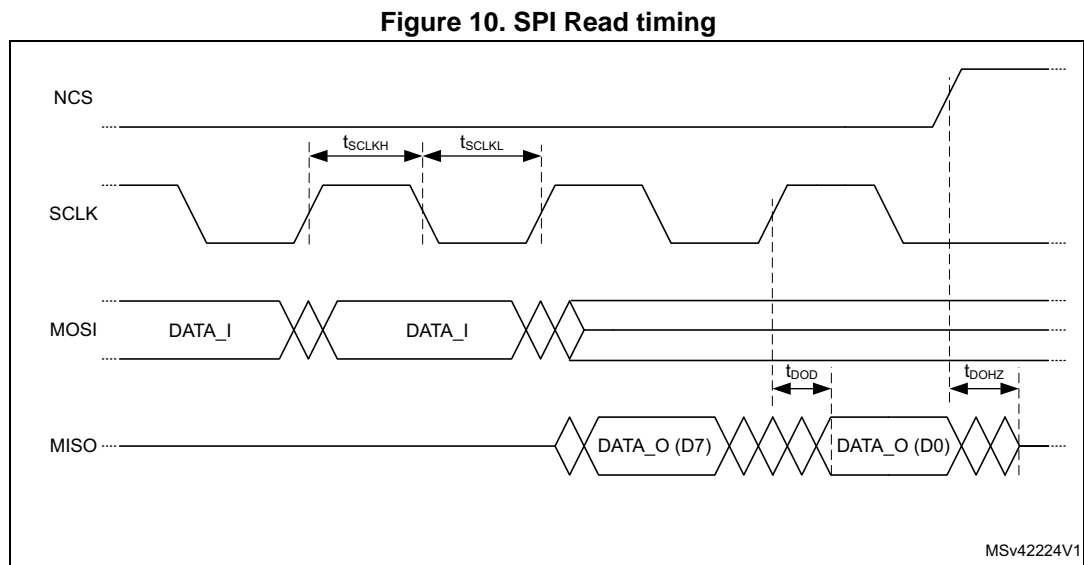

Figure 10 shows the corresponding timing waveforms and parameters for the SPI read command.



### 2.2.5 CLSYS output

The CLSYS output is intended to be used as a MCU clock source. Available frequencies are:

- 4 MHz
- 5 MHz
- 10 MHz
- 20 MHz

The CLSYS frequency is defined by clsys[2:0] option bits in the *Miscellaneous register 2* (0Eh).

### 2.2.6 IO signal level and output characteristics

The logic high level for the host communication and CLSYS is defined by the supply voltage connected to VDD\_IO pin. The logic high level can be in the range between 1.65 V and 5.5 V. VDD\_IO should be connected to the host system periphery supply voltage to ensure matching communication levels.

The digital outputs are by default configured for high-speed operation. A 5 MHz SPI clock is possible with a 50 pF capacitive load on the MISO and IRQ outputs and a minimum VDD\_IO supply voltage of 3 V. A 3 MHz SPI clock is possible with a 50 pF load and a minimum VDD\_IO supply voltage of 1.65V.

To decrease the harmonic content of the digital output signals, it is possible to configure the device outputs to provide weak, sloped output signals by setting the hs\_output option bit in the *Miscellaneous register 1* (0Dh) to low. In this configuration the possibility of interferences by the host system communication with other internal building blocks of the device is mitigated as well. Using this option a 2 MHz SPI clock is possible with maximum 50 pF capacitive load on MISO and IRQ and at least a VDD\_IO supply voltage of 3 V.



It is also possible to define open drain N-MOS outputs by setting the option bit `open_dr` high (register 0Dh). This option reduces the harmonic content on the MISO, IRQ, and CLSYS signals further. It also decreases cross-coupling effects that could interfere with operation of other blocks of the device.

### 2.2.7 OAD, OAD2 outputs

The OAD and OAD2 outputs are analog and digital test outputs. When used as analog outputs, the received sub-carrier signals or mixer analog DC output levels are multiplexed at these pins. The signal is centered to AGD level. When used as digital output, the levels are configured with VDD\_IO. The OAD pins can be configured as high speed outputs by setting the option bit `hs_oad` in the *Miscellaneous register 1* (0Dh). During normal operation it is not recommended to use `hs_oad`, as higher harmonic content can increase the crosstalk to sensitive pins of the device.

## 2.3 PLL and VCO section

The PLL section comprises a voltage controlled oscillator, a pre-scaler, main and reference dividers, a phase-frequency detector, a charge pump and a loop filter.

Figure 11 shows a detailed block diagram of the PLL and VCO section of the ST25RU3993 device.

Figure 11. PLL and VCO section

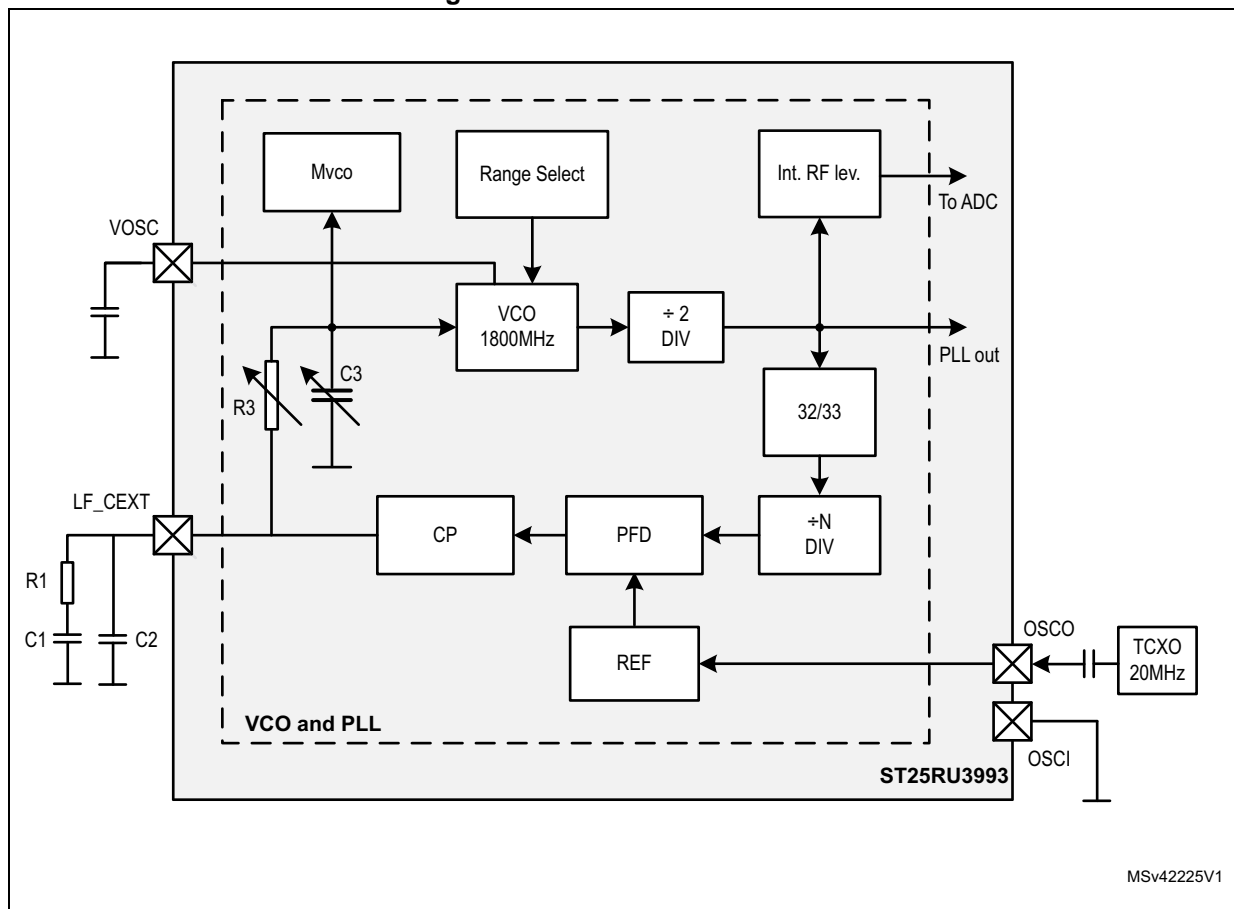

MSv42225V1

All building blocks, except a section of the loop filter, are integrated in the ST25RU3993. The allowed frequency operation range is 840 MHz to 960 MHz.

### 2.3.1 Voltage controlled oscillator

The VCO is entirely integrated, including the variable capacitor and inductor. The frequency control input pin is LF\_CEXT. The valid voltage range is between 0.5 V and  $V_{DD\_A} - 0.5$  V. The option bits eoscl[2:0] in the [VCO control register](#) (11h) are used for oscillator noise and current consumption optimization. Power supply decoupling is done via VOSC pin. The internal VCO frequency is set in the range of 1800 MHz, which is internally divided by two for decreased VCO pulling effect. The tuning curve of the 1800 MHz VCO is divided into 16 segments (ranges) to decrease the VCO gain and to attain lowest possible phase noise.

#### VCO tuning range selection

The selection of the VCO tuning range can be done manually by setting the option bits vco\_r[3:0] in the [VCO control register](#) (11h). An automatic selection can be started by using the direct command automatic VCO Range Selection (A4h). Reverting back to manual selection is possible by sending the direct command manual VCO range selection (A5h). The automatic VCO range selection (A4h) command starts a search algorithm that finds the appropriate VCO segment. When the algorithm is finished an IRQ request is sent with Irq\_cmd and autovco\_done status bit in the [Command status display register](#) (2Eh) set high.

#### Readout of VCO tuning range status

The result of the automatic segment search algorithm is represented by vco\_ri[7:4], which can be read out from the device via the [AGL/VCO/F\\_CAL/PilotFreq status register](#) ( $r2Cpage[1:0] = 01$ ) (2Ch) when option bits r2Cpage[1:0] = 01b (register 29h).

#### VCO control voltage measurement

It is possible to measure the VCO control voltage by setting option bit mvco in [VCO control register](#) (11h) to high. The 3 bits result vco\_ri[2:0] can be read from the [AGL/VCO/F\\_CAL/PilotFreq status register](#) ( $r2Cpage[1:0] = 01$ ) (2Ch) using r2Cpage[1:0] = 01b (register 29h). During normal operation, the mvco option bit in register 11h should remain low. Details on using the 1800 MHz VCO are described in a dedicated application note.

### 2.3.2 PLL prescaler and main divider

The divide-by-32/33 prescaler is controlled by the N-divider. The divider ratio is defined by the [PLL main register 1](#) and [PLL main register 3](#) (17h-19h) or [PLL auxiliary register 1](#) and [PLL auxiliary register 3](#) (1Ah-1Ch). The lower ten bits of the three main (aux.) registers define the A value and the next upper ten bits define the B value. The A and B values define the main divider dividing ratio to:

$$N = B \cdot 32 + A \cdot 33$$

The two registers [PLL main register 1](#) and [PLL main register 3](#) and [PLL auxiliary register 1](#) and [PLL auxiliary register 3](#) are intended to support frequency hopping using the direct commands hop to main frequency (84h) and hop to auxiliary frequency (85h).

### 2.3.3 PLL reference frequency

The reference frequency is selected by the RefFreq[2:0] bits in the *PLL main register 1* (17h). Available values are:

- 125 kHz
- 100 kHz
- 50 kHz
- 25 kHz

### 2.3.4 Reference frequency source

For the reference frequency a frequency source of 20 MHz is required. It is possible to use an external oscillator (TCXO) or a quartz crystal. If a TCXO is used, it should be connected to the OSCO pin while the OSCI pin should be shorted to ground. The signal shape of the TCXO should be of a sinusoidal type and AC coupled. The level should be in the range between 0.8 V<sub>pp</sub> and 3 V<sub>pp</sub>. A low OSCO level is recommended to minimize the spectral signal components spaced by  $\pm 20$  MHz around the Tx carrier frequency. The OSCO input impedance in this mode is typically 9 k $\Omega$ , with 9 pF in parallel. A crystal should be connected between the OSCI and OSCO pins with appropriate load capacitors in shunt configuration to ground. Load capacitances in the range from 15 pF to 20 pF are recommended. The maximum series resistance in resonance should be 30  $\Omega$ . The crystal oscillator is started-up in fast mode in order to speed-up a stable crystal oscillation. The device then switches back to the power saving mode. The device operation typically uses the power saving mode. Option bits xosc[1:0] in the *Miscellaneous register 2* (0Eh) are available to manually control the crystal operation modes.

### 2.3.5 Phase-frequency detector and charge pump

The reference frequency and the divided RF frequency are compared in the phase-frequency detector that drives the charge pump connected to the LF\_CEXT pin. The charge pump current is selectable between 150  $\mu$ A and 2350  $\mu$ A using option bits cp[2:0] in the *CP control register* (12h).

### 2.3.6 Loop filter

The loop filter is composed of an external and an internal portion. The first stage (series capacitor, series resistor and shunt capacitor) is external and is connected to the pin LF\_CEXT. The second stage (R3/C3 filter) is internally connected between the LF\_CEXT pin and the VCO control input.

The values for the internal part of the loop filter (R3 and C3) can be selected by option bits LF\_R3[7:6] and LF\_C3[5:3] both in the CP Control Register (12h). R3 can be set in a range from 30 k $\Omega$  to 100 k $\Omega$  and C3 can be set in a range from 20 pF to 200 pF.

### 2.3.7 Frequency hopping commands

Frequency hopping is possible by issuing the direct commands Hop to main frequency (84h) and hop to auxiliary frequency (85h) that set the main divider ratio either to the main or the auxiliary PLL register. The host system (MCU) is responsible to perform correct frequency hopping according to local regulations.

### 2.3.8 PLL start-up and frequency hopping

Before enabling the RF field, the host system needs to configure the PLL through the *CP control register* (12h) and the *PLL main register 1*, *PLL main register 2* and *PLL main register 3* (17h, 18h, 19h). The PLL should be locked using one of the above defined possibilities. Any time during operating at one frequency, the host system can fill the auxiliary PLL main registers. When the frequency hop needs to be performed only the appropriate frequency hopping direct command needs to be sent to the device.

## 2.4 Device status control

In the *Device status control register* (00h), the main functionality of the device is controlled. By setting the option bit *rf\_on*, the internal transmitter and receiver blocks are enabled. The initial RF field ramp-up is defined by the *Tari*[2:0] option bits in the *Tx options register* (02h) and by option bits *trfon*[1:0] in the *Modulator control register 3* (15h).

The available values are:

- 100  $\mu$ s
- 200  $\mu$ s
- 400  $\mu$ s
- TARI determined

When finished, the *rf\_ok* bit in the *AGC and internal status display register* (2Ah) is set and an IRQ with *Irq\_ana* bit is sent. By setting the *rf\_on* bit low, the RF field is ramped-down similarly to the ramp-up transient and an IRQ with *Irq\_ana* bit set is sent. The *rec\_on* bit enables the receiver only. The *agc\_on* bit enables the AGC functionality. The *stby* bit puts the device into the standby mode.

## 2.5 Protocol control

In the *Protocol selection register* (01h), the main protocol parameters are selected. The *prot*[2:0] option bits should be set to 000b for EPC Class1 Gen2 operation and to 001b for ISO18000-6A/B FM0 decoder operation. The *AutoACK*[1:0] bits enables the automatic inventory round sequencing and define its depth. There are three possible modes:

- No automatic
- Automatic ACK
- Automatic ACK + ReqRN

The option bit *RX\_crc\_n* = 1 defines reception with no internal CRC check. The CRC is then just passed on to the FIFO like any other data bytes. In the EPC Gen 2 protocol this is a useful feature in case of a truncated EPC reply, where the stored CRC that a transponder transmits is not calculated over the actual transmitted data and is therefore an invalid CRC. The *dir\_mode* bit defines the type of output signals while operating in the direct mode. It also disables any decoding and signal sensing automatics during the reception. It is advised to set this bit high when continuous analog measurements are performed.

## 2.6 Transmission section

The transmitter section comprises a data handling, an encoding part, a shaping circuitry, a modulator and amplifier circuitry.

Figure 12. Transmission section

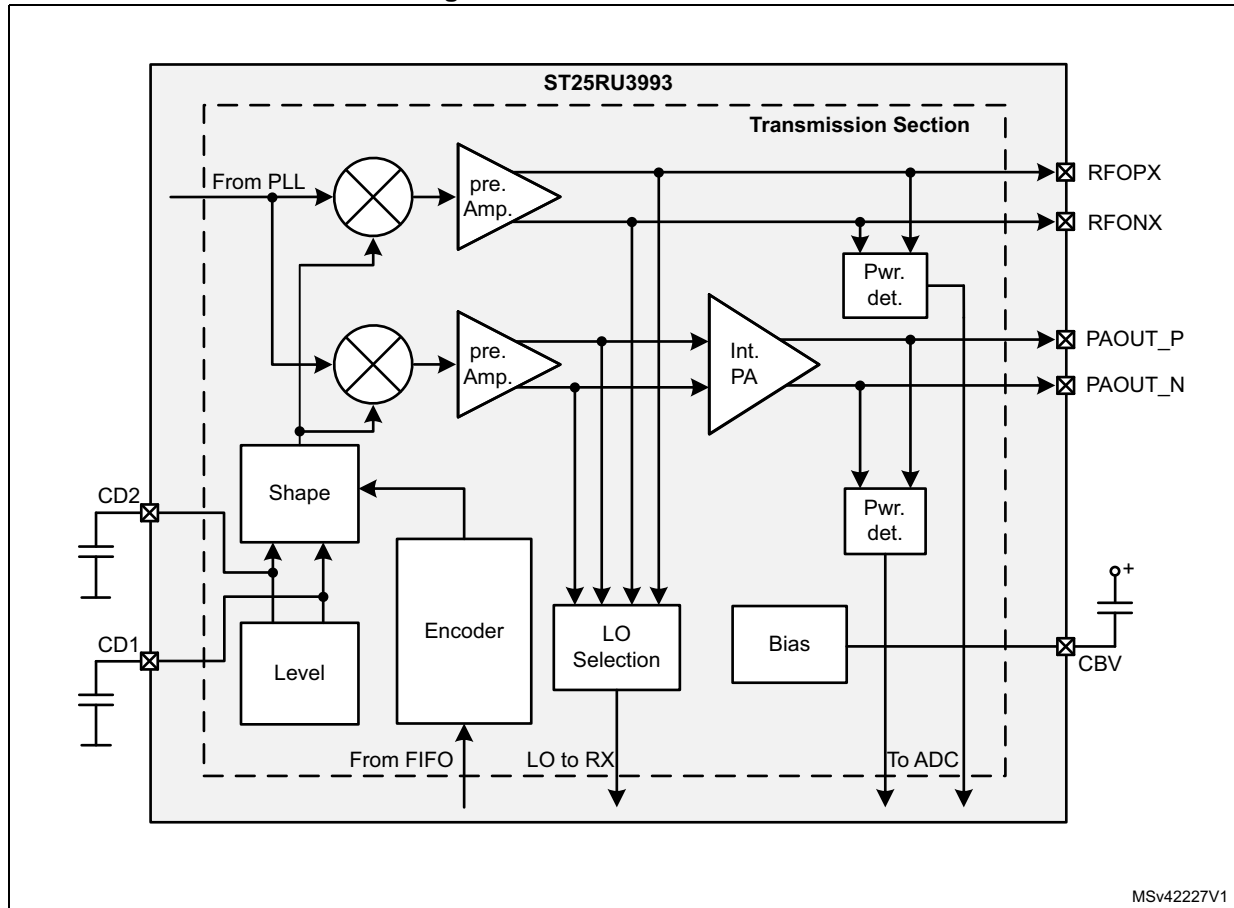

The RF carrier is modulated with a shaped representation of the transmit data and (pre-)amplified for transmission.

### 2.6.1 Tx data handling and coding

The data handling part takes the baseband data from the FIFO and encodes it according to the Gen2 protocol (PIE). It adds a preamble or a frame-sync and calculates the CRC. The digital modulation signals are fed to the shape circuitry.

### 2.6.2 Tx shape circuitry

The modulation shape is controlled by a double D/A converter. The first 5-bit logarithmic converter creates two voltages, which define minimum and maximum ( $V_{pp}$ ) modulation signal level. The two voltages are filtered by two external capacitors connected to the CD1 and CD2 pins to minimize the noise level and are used as a reference for the shaping circuitry. The second 9-bit linear converter transforms the digital modulation signal into a sinusoidal or linear shaped analog modulation signal. The output of the shaping circuit is interpolated and connected to the modulator input.

### 2.6.3 Local oscillator (LO) path

To improve the phase noise rejection, the local oscillator signal is derived from the output of the pre-amplifier stages. For optimal operation, the pre-amplifier levels should be close to nominal (set by TX\_lev[4:0] in register 15h). If lower levels are used, the LO signal can be increased by approximately 6 dB using option bit eTX[7]. The drawback is increased received noise.

### 2.6.4 Modulator

The modulator modulates the RF carrier with the shaped representation of the digital modulation signal. The internal modulator is capable of ASK and PR-ASK modulation.

#### Tx level and shape adjustments

The output level and modulation shape properties are controlled by the *Modulator control register 1* and *Modulator control register 4* (13h-16h). The level of the output signal is adjusted by option bits TX\_lev[4:0] in *Modulator control register 3*(15h). For good performance, it is advised to design the external circuit of the reader device to have the reader output power close to the ST25RU3993 nominal output power. If temporarily operation at decreased power is need the TX\_lev[4:0] option bits should be used.

Sinusoidal or linear shape is defined by the option bit lin\_mod in register (15h). PR-ASK modulation is selected by setting the pr\_ask option bit to high. If PR-ASK is selected, the del\_len[5:0] option bits are used to adjust the delimiter length in the range from 9.6  $\mu$ s to 15.9  $\mu$ s. For Tari = 25  $\mu$ s PR-ASK and ASK delimiter shapes are available. The ASK transient which gives more accurate timing can be selected by the ook\_ask option bit in register 15h. For Tari = 12.5  $\mu$ s and 6.25  $\mu$ s only the ASK delimiter shape is available.

ASK modulation is selected by setting the pr\_ask option bit to low. In ASK modulation it is possible to adjust the delimiter length by setting the option bit ook\_ask. In this case, ook\_ask defines 100% ASK modulation and the del\_len[5:0] bits are used for delimiter length setting as in the PR-ASK mode described above.

The rate of the modulation transient is automatically adjusted to the selected Tari setting and can be re-adjusted by the ask\_rate[1:0] option bits (register 13h). For smoother transitions of the modulation signal an optional low pass filter can be activated by the e\_lpf option bit in the *Modulator control register 1* (13h). Bits aux\_mod and main\_mod define whether the modulation signal will be connected to the low-power output or to the internal PA output path. If one of the outputs is enabled by the eTX[3:0] bits in *RF output and LO control register* (0Ch) and corresponding aux\_mod or main\_mod bit is low, the output is enabled but not modulated (the device would output only a continuous wave signal).

## 2.7 Tx outputs

Two Tx differential output ports are available:

- Differential low-power, high linear output (nom. 0 dBm)
- Differential high power output (nom. 20 dBm)

The low-power output can be used to drive an external PA to generate a high power RF signal. The internal high power output can be used to directly drive an antenna suitable for applications with low to medium read range requirements.

### low-power output

The differential low-power, high linear RF outputs (~0 dBm) are intended to be used to drive an external amplifier. The RF outputs composed of RFOPX and RFONX pins need external RF chokes connected to VDD\_B, decoupling capacitors and a Balun with 2:1 impedance ratio for optimal operation in a 50  $\Omega$  system. The output is enabled by eTX[1:0] bits in the [RF output and LO control register](#) (0Ch). By using these bits, it is possible to adjust current capability of the RF output pins.

### High power output

The differential high power output pins are the outputs of the internal power amplifier outputs PAOUT\_P and PAOUT\_N. They require external RF chokes, connected to VDD\_PA and an impedance matching circuit for operation in a 50  $\Omega$  system. The amplifier is enabled by the eTX[4] and eTX[3:2] option bits in register 0Ch. Bit eTX[3:2] also define the bias of the internal pre-amplifier stage. The PA supply regulator is automatically enabled when the internal PA is enabled. The bias current for the internal PA is defined by the option bits pa\_bias[1:0] in the [Regulator and PA bias register](#) (0Bh).

## 2.8 Tx operation modes

### 2.8.1 TX normal mode

The baseband data is transferred to the 24 byte FIFO and the complete signal processing (protocol encoding, adding preamble or frame-sync, CRC, signal shaping, and modulation) is done internally. The data is then coded to the modulation pulse level and sent to the modulator. This means that the MCU has only to load the FIFO with data.

#### Transmission start

There are three possibilities to start data transmission in the normal mode.

The first one is data transmission that can be triggered by sending related direct commands:

- Transmission with CRC (90h)
- Transmission with CRC Expecting Header Bit (91h)
- Transmission without CRC (92h)

followed by information about the number of bytes that should be transmitted and the baseband data. The number of bytes that needs to be written into the [Tx length register 1](#) and [Tx length register 2](#) (3Dh, 3Eh) and the data itself should be put into the [FIFO I/O register](#) (3Fh). Both operations can be done with one continuous Write command. The transmission is started when the first data byte is completely written to the FIFO.

The second possibility to trigger the transmission is with one of the direct commands related to the EPC Class1 Gen2 protocol:

- Inventory Commands:
  - Query (98h)
  - QueryRep (99h)
  - QueryAdjustUp (9Ah)
  - QueryAdjustNic (9Bh)
  - QueryAdjustDown (9Ch)
- ACK (9Dh)
- ReqRN (9Fh)

In this case, the transmission is started upon receiving the command.

The third possibility for data transmission is using one of the AutoACK modes. In this case the ACK or ReqRn is sent automatically if the previous reception was successful.

During data transmission, the TX\_status bit in the *FIFO status register* (39h) is set. When the data transmission is finished, the reader device signals an IRQ request with Irq\_TX bit set high.

### Protocol adjustments

The EPC Class1 Gen 2 protocol allows the user to adjust transmission parameters. The three supported Tari values are selected by changing the Tari[1:0] option bits in the *Tx options register* (02h). The length of the high period of the (PIE encoded) logical one is selected by TXOne[1:0] option bits in the *Tx options register* (02h). The session parameters for the direct command Query (98h) are defined by the S1 and S0 option bits in the *Tx setting register* (3Ch). TRcal, which defines the backscatter link frequency, is incorporated in the Query command transmission. TRcal is defined by option bits TRcal[11:0] in the TRcal Registers (04h, 05h).

**Caution:** The software designer needs to take care that bits TRcal[11:0], RX\_LF[3:0] and the DR bit in the transmission of the Query command follow the Gen2 protocol. A precise description can be found in the EPC Class1 Gen2 or ISO18000-6C protocol description. If TRcal data is required in normal transmission, it can be set by Force\_TRcal option bit in the *Tx setting register* (3Ch). The cyclic redundancy check can be changed to CRC-5 instead of CRC-16. This is done in normal transmission by setting TXCRC\_5 option bit in the *Tx setting register* (3Ch) to high.

### Transmission FIFO

The reader device supports two fully separate 24-byte FIFO buffer registers, one for transmission and one for reception. They share the same address. By writing to FIFO address 3Fh the data will be passed to transmission FIFO, while reading from the register address 3Fh will fetch the values from the reception FIFO. This approach makes it possible to start a new transmission before the previously received data is read out by the MCU.

If the data bytes to transmit exceed the size of the FIFO buffer, the MCU should initially fill the FIFO register with 24 bytes. The reader device starts the transmission and sends an interrupt request, signaled by irq\_fifo in the *Interrupt register 1* (37h), when only 6 bytes are left in the FIFO. When the interrupt is received, the MCU needs to read from register 37h. By reading this register, the host system will know the cause for the interrupt and at the same time clear the interrupt bit. After this the MCU puts the remaining transmission data bytes to the FIFO considering the available FIFO size. If all transmission data bytes were



already sent to the FIFO, the host system waits until the last data byte has been sent. The end of the transmission is signaled to the MCU by the IRQ request irq\_TX in register 37h. The two *Tx length register 1* and *Tx length register 2* (3Dh, 3Eh) support incomplete byte transmission. The MCU needs to define the number of complete bytes and the number of the remaining bits that should be transmitted.

## 2.8.2 TX direct mode

Direct mode is chosen when using only analog functions, bypassing all the protocol handling support of the reader device.

### Entering and terminating the direct mode

To enter the direct mode the direct command direct mode (81h) should be sent followed by a NCS low-to-high transition. The direct mode remains active as long as NCS is kept high. To terminate the direct mode the direct command block Rx (96h) needs to be sent immediately after the NCS high-to-low transition. During the same or consecutive NCS low periods normal communication via the SPI interface is possible again.

### Direct Mode Signals

The *Table 6* shows the re-assignments of the I/O pins during the direct mode. The different reception outputs options are related to the dir\_mode option bit in the *Protocol selection register* (01h).

**Table 6. I/O pin reassignment in direct mode**

Pin Name	Bit Stream and Bit Clock Output (dir_mode = 0)	Sub Carrier Output (dir_mode = 1)
MOSI	Tx data input	Tx data input
SCLK	Enable Rx input	Enable Rx input
MISO	Rx data output	I-Channel subcarrier output
IRQ	Rx bit clock output	Q-Channel subcarrier output

In the direct mode the MCU must directly control the transmission modulation input pin MOSI (Tx data input). The RF field is set to a high level if MOSI is high and to low if MOSI is low. The circuitry shapes the field according to the settings in the *Modulator control register 1* and *Modulator control register 3* (13h-15h) and transmits the signal.

## 2.9 Receiver

The receiver section comprises two input mixers followed by a fast AC coupling, gain and filtering stages, and a digitizer. The two received signals are fed to the decision circuitry, the bit-decoder and the framer, where the preamble is removed and CRC is checked. The clean, framed baseband data is accessible for the MCU via the 24-byte *FIFO I/O register* (3Fh).

The receiver section is activated by the option bits rec\_on or rf\_on from the *Device status control register* (00h). The typical bias settling time is 3 ms if the reader device was previously in the normal mode (EN=H and stby=0). If the rec\_on bit is set together with the EN pin or a stby high-low change, the normal mode power-up timing prevails.

Figure 13 shows a detailed block diagram of the receiver section of the ST25RU3993 device.

Figure 13. Receiver section

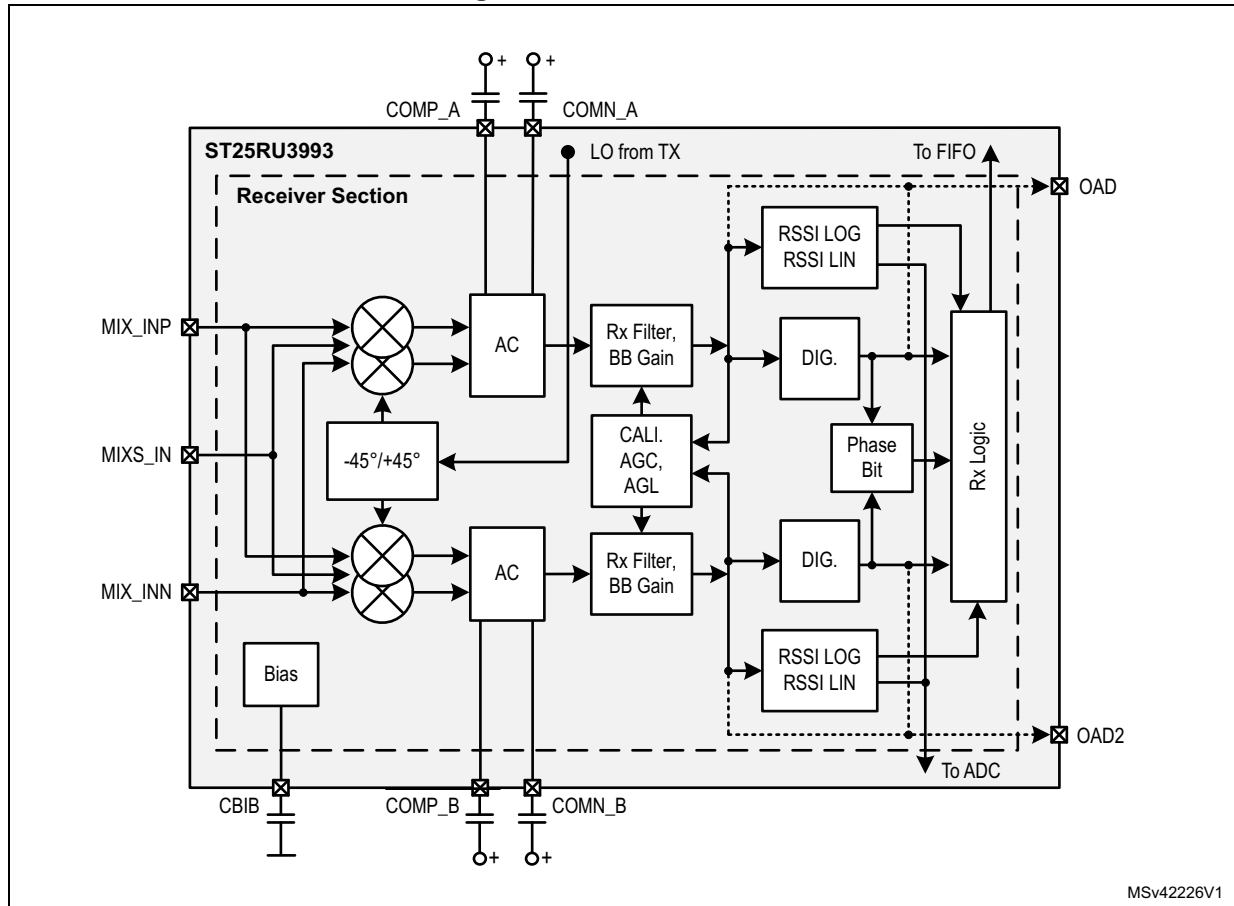

### 2.9.1 Input mixers

The two input mixers are driven with 90° shifted LO signals and form an IQ demodulation circuit. By using an IQ demodulator architecture the AM-input signals are demodulated in the in-phase channel (I) while the PM-input signals are demodulated in the quadrature phase (Q) channel. The mixture of AM and PM-input signals is demodulated in both receiving channels. This configuration results in reliable operation, even if the transponder presents amplitude or phase modulation at receiver’s input, as it suppresses communication holes caused by alternating modulation types. A differential input mixer and a single ended input mixer are available.

#### Differential input mixer

The pins MIX\_INP and MIX\_INN are the inputs for the differential Rx mixer. The inputs should be AC coupled to the external circuitry. At power-up the device automatically chooses the differential Rx mixer. If the differential Rx mixer is not used the input pins should be shorted to ground. To optimize the receiver noise and input range properties, the differential Rx mixer features settings to adjust the input range. Depending on the reflectivity of the environment and the antenna properties, the receiver’s input RF voltage may

increase to a level at which the differential Rx mixer operation gets corrupted. In such a case the input range can be extended by activating the internal input attenuator by setting the option bit `mix_ir[0]` in the *Rx mixer and gain register* (0Ah) to high. If of low unwanted reflected power (self-jammer), the host system can increase the mixer conversion gain improving the overall sensitivity of the receiver by setting the option bit `mix_ir[1]`. The drawback of this setting is a reduced dynamic input range.

Additional settings in *Emitter-coupled mixer options register* (22h):

- `emix_vr[0]`: (i2x) Increase differential Rx mixer range in mixer gain mode (~3dB)
- `emix_vr[1]`: (vsp\_low) Adapts differential Rx mixer bias points to low supply
- `iadd_sink[2:0]`: Select differential Rx mixer load stage

### Single ended input mixers

The single ended input mixer has emitter-coupled input topology. The input MIXS\_IN pin should have a DC path to ground and should be AC coupled for the RF input signal. The single ended input mixer needs to be activated by `s_mix` bit in the *Miscellaneous register 1* (0Dh).

Following options are available to optimize mixer operation for different mixer input ranges, sensitivity and current consumption requirements:

- `mix_ir[1:0]`: Select internal mixer impedance and gain in the *Rx mixer and gain register* (0Ah)
- `emix_vr[2:0]`: Select mixer input voltage range in the *Emitter-coupled mixer options register* (22h)

`id2x`, `id1x5`, `iadd_sink[2:0]`: Select mixer load stage current in the *TRcal high register* (04h) and the *Emitter-coupled mixer options register* (22h).

## 2.9.2 Local oscillator path

To improve the phase noise rejection, the local oscillator signal can be derived from RFOPX, RFONX or the internal pre-amplifier stage of the internal PA. The source from which the LO signal is tapped is selected by the `eTX[6]` option bit in the *RF output and LO control register* (0Ch). When using output RF levels lower than nominal, the LO signal can be increased by ~6 dB by setting the option bit `eTX[7]` to high. The drawback of this setting is an increase of received noise.

## 2.9.3 Fast AC coupling

The internal feedback AC coupling system stores the DC operating points prior the start of the transmit modulation. After data transmission the system progressively adjusts the high pass time constant, resulting in a very fast settling time before reception. Such a system is required to accommodate the short Tx-to-Rx time needed for the highest bit rates in the EPC Class1 Gen 2 protocol.

## 2.9.4 Rx filter

### Filter topology

The Rx filter is composed of four filter stages:

- 4th-order elliptic low-pass with notch characteristic to suppress neighboring channels at 500 kHz or 600 kHz. The filter can be configured to have its 1dB-compression point

at 360 kHz for ETSI and at 280 kHz for FCC channel spacing in DRM operation. This filter stage allows one non-DRM setting:

- 800 kHz low-pass corner frequency for BLF = 640 kHz.
- 2nd-order high-pass Chebyshev filter with an adjustable 1dB-compression point from 72 kHz to 200 kHz. This filter stage can be switched off (its gain stage only) for lower LF frequencies.
- 2nd-order low-pass Chebyshev filter with its 1dB-compression point at 360 kHz for ETSI and 280 kHz for FCC channel spacing in DRM operation. This filter stage allows three non-DRM settings:
  - 800 kHz low-pass corner frequency for BLF = 640 kHz
  - 180 kHz low-pass corner frequency for BLF = 160 kHz
  - 72 kHz low-pass corner frequency for BLF = 40 kHz
- 2nd-order high-pass Chebyshev filter with an adjustable 1dB-compression point from 72 kHz to 200 kHz. This filter stage can be reconfigured to 1st order high-pass with -3 dB frequency at 5.5 kHz or 12 kHz for the lower BLFs and FM0 coding.

**Rx filter characteristics**

Rx Filter characteristics are defined via the option bits in the *Rx filter setting register* (09h). The hp[3:1]option bits define the high-pass corner frequency and lp[3:1] define the low pass corner frequency. The bits byp1 and byp2 bypass some stages allowing operation at lower back-scatter link frequencies. Since the settings of the different filter stages partially influence each other, many different overall filter characteristics can be accomplished. The register 09h should be set to FFh. Available register settings and their typical Rx filter characteristics are shown in the *Table 7*.

**Table 7. Rx filter characteristics (register 09h)**

Filter Setting	-3 dB HP Frequency	-3dB LP Frequency	Attenuation at 40 kHz	Attenuation at 600 kHz	Attenuation at 1.2 MHz
BLF = 640 kHz					
reg09:00	220 kHz	770 kHz	-55 dB	-	-35 dB
reg09:07	80 kHz	770 kHz	-18 dB	-	-35 dB
BLF = 320 kHz (ETSI DRM)					
reg09:20	200 kHz	380 kHz	-50 dB	-40 dB	-54 dB
reg09:27	75 kHz	380 kHz	-18 dB	-40 dB	-54 dB
BLF = 250 kHz (FCC DRM)					
reg09:30	200 kHz	320 kHz	-50 dB	-45 dB	-55 dB
reg09:37	75 kHz	320 kHz	-18 dB	-45 dB	-55 dB
BLF = 160 kHz					
reg09:3B	110 kHz	245 kHz	-	-52 dB	-56 dB
reg09:3F	55 kHz	245 kHz	-	-52 dB	-56 dB
BLF = 40 kHz					
reg09:FF	7 kHz	80 kHz	-	-60 dB	-55 dB



### Proposed filter settings

Not all filter settings prove useful during operation. [Table 8](#) shows proposed registers settings, which provide optimal overall Rx filter characteristics for the supported link frequencies and Rx coding.

**Table 8. Proposed Rx filter settings for supported link modes**

Link Frequency	Rx Coding	Register 09h settings
DRM Modes		
320 kHz	M4	24h
	M8	
250 kHz	M4	34h
	M8	
Other Supported Modes		
40 kHz	FM0	FFh
	M2	
	M4	
	M8	
160 kHz	FM0	BFh
	M2	3Fh
	M4	
	M8	
640 kHz	M4	04h
	M8	

### Rx filter calibration

To compensate process and temperature variations of the internal resistor and of the capacitor values, a filter calibration procedure is available. The calibration procedure is triggered by the direct command trigger Rx filter calibration (88h). The calibration is finished after 5 ms (max.) and should be triggered after power-up, prior the first reception and later from time to time especially if a significant temperature change has occurred.

The result of this calibration is represented by the lp\_cal[3:0] and hp\_cal[3:0] status bits in the [AGL/VCO/F\\_CAL/PilotFreq status register \(r2Cpage\[1:0\] = 01\)](#) (2Ch) using r2Cpage[1:0] = 10b. Typical calibration result values are 88h. The automatically calibrated values can be adjusted by the direct commands decrease Rx filter calibration data (89h) and increase Rx filter calibration data (8Ah), if the enabling option bit f\_cal\_hp\_chg in the [Miscellaneous register 2](#) (0Eh) was set to high before.

Note that hp\_cal[3:0] affects the high pass part of the filter characteristic while lp\_cal[3:0] affects the low pass part of the filter characteristic, both in 4% steps. Range is  $\pm 30\%$ .

## Rx gain and digitizer hysteresis

The Rx gain in the receiving chain and digitizer hysteresis can be adjusted to optimize the signal to noise and interference ratio. There are three ways for adjustment:

- Manual
- AGC
- AGL

### Manual Adjustment

This adjustment method is done by setting option bits in the *Rx mixer and gain register* (0Ah). The bits gain[2:0] increase the digitizer hysteresis by 3 dB per step (7 steps) and the bits gain[5:4] change the baseband amplifier gain by 3 dB per step (3 steps). The sign of the change (increase or decrease) is defined by the option bit gain\_sign.

### AGC

The built-in AGC comprises a system acting during the first periods of the incoming preamble. It partly changes the digitizer hysteresis (steps 1 - 4) and partly the baseband gain (steps 5 - 7). The hysteresis and baseband gain are changed equally for both channels maintaining the ratio between the I and Q channel so that the stronger signal is correctly digitized. The AGC can be enabled by setting the option bit agc\_on in the *Device status control register* (00h) to high. The status of the AGC can be seen by the agc[2:0] status bits in the *AGC and internal status display register* (2Ah). The register value represents the number of 3 dB steps.

### AGL

This adjustment is another possibility to decrease the sensitivity in case of bad reception conditions due to environmental noise and interferences. The AGL can be triggered by the direct command AGL On (A6h), during rf\_ok = 1 after the direct command enable Rx (97h) has been sent and during a period when there is no actual transponder response pending. This means that the RF ramp-up must be finished and the receiver is ready to receive the interference signals. This automatic feature increases the digitizer hysteresis for each channel independently to a level just above the noise and interference level. The maximum time required for the AGL action is 1 ms. The AGL result status for each channel can be seen by reading the agl[5:0] status bits in the *AGL/VCO/F\_CAL/PilotFreq status display register (r2Cpage[1:0] = 00)* (2Ch) using r2Cpage[1:0] = 00b. The register values represent the number of 3 dB steps. There are four active steps available, while steps 5 - 7 are inactive (0 dB). The AGL is disabled by AGL Off (A7h) direct command. The result is stored and remains valid until the direct command AGL Off (A7h) was sent.

The difference between AGC and AGL is that AGC runs each time at the beginning of the data packet reception, while AGL only runs when the direct command AGL On (A6h) is sent.

Both AGC and AGL operate on the gain[2:0] bits in the *Rx mixer and gain register* (0Ah) and should be used exclusively. The manual setting has lower priority. In general, the system gain should be set to a level, that in good (normal) conditions only a small number of transitions occur on the digitizer output when no tag is transmitting. In such a case, also no AGL change would be seen.

## 2.9.5 IQ selection

The two receiving signals are digitized and evaluated. The decision circuit selects the in-phase signal or quadrature signal channel, whichever presents the better received signal,

for further processing. The chosen signal channel can be seen by reading the `in_select` status bit in the [AGL/VCO/F\\_CAL/PilotFreq status display register \(r2Cpage\[1:0\] = 00\)](#) (2Ah). This bit is valid from the end of the preamble until the start of the next transmission. For FM0 Rx encoding the selection is based on the evaluation of the digital representation of the received sub-carriers at the beginning of the data packet. For Miller Rx encoding the selection is supported by the logarithmic RSSI measurement. RSSI will be taken into account if at least one RSSI reading (I or Q) is higher than defined by the `IQsel_Th[3:0]` option bits in the [Interrogator collision detection and IQ selection settings register](#) (1Dh). Further improvements can be achieved by taking noise RSSI into account. To enable this mode (an active RF field and all mixer and gain settings as used for the subsequent reception are required) send the direct commands `enable Rx` (97h) and `Store RSSI` (A8h). As a result only the difference between actual pilot RSSI and the stored noise RSSI will contribute to the IQ decision.

### 2.9.6 Bit decoder

The bit decoder converts the sub-carrier coded signals to a bit stream data according to the protocol defined by the option bits `RX_cod[2:0]` and `RX_LF[3:0]` in the [Rx options register](#) (03h). The system extracts the data clock and serial data bits, and removes the preamble. The decoder logic is designed for maximum error tolerance to enable successful decoding of partly corrupted sub-carrier signals due to noise or interference. In the EPC Class1 Gen2 protocol, the decoder supports long Rx preamble (`TRext = 1`) for FM0, and all Miller encoded signals. Short Rx preamble (`TRext = 0`) is supported for Miller4 and Miller8 encoded signals.

### 2.9.7 Data framer

In the data framer, the serial bit stream is formatted into bytes. The CRC bytes are checked and removed leaving pure baseband data, which is sent to the 24-byte FIFO register from where it can be read out by the MCU. The receiver also supports transfer of incomplete bytes.

## 2.10 Data reception modes

The device can operate in the normal mode or in direct mode.

### 2.10.1 Rx normal mode

In the normal mode the received data is stored in FIFO.

#### Reception start

The reception is triggered automatically at the end of the data transmission.

The second option to start the reception is done manually by sending the direct command `enable Rx` (97h). For correct operation, the `dir_mode` bit in the [Protocol selection register](#) (01h) should be set to 0.

The third possibility to start reception is using one of the AutoACK modes, which automatically triggers the reception to acquire PC+EPC and Handle.



### Rx wait timer

The Rx wait timer defines a wait time between the end of data transmission and start of data reception. During this period, the decoder is not active. This prevents any incorrect detection that could occur due to transients caused by transmit operation, by noise or interference. The Rx wait time setting is done by the RXw[7:0] option bits in the *Rx wait time register* (08h). The step size for the Rx wait time is 6.4  $\mu$ s.

### Rx no response timer

The Rx no response timer starts with the reception slot of the anti-collision algorithm until a tag response arrives. In case no tag response is received during the defined time, the reception terminates and an IRQ is triggered with the Irq\_noresp bit set. In case the e\_irq\_noresp option bit in the *Enable interrupt register 1* (35h) is set, the reception is not terminated by the Rx No Response Timer. Therefore the reception needs to be terminated manually by sending the direct command Block Rx (96h). This mode is designed for commands where the response time can be long or not defined. The Rx no response timer is controlled by the *Rx no response time register* (07h). This time is defined in 25.6  $\mu$ s steps. In case the timer is set to FFh the Rx no response time is fixed to 26.2 ms.

### Decoder operation

During data reception the Rx\_status bit in the *FIFO status register* (39h) is set high and when the data transmission is finished, the reader device issues an IRQ request with the Irq\_RX bit set. In the Rx FIFO buffer 24 bytes can be stored. In case the number of received data bytes is higher than 18, an IRQ request with the Irq\_fifo bit set high (register 37h) signals to the MCU that data should be removed from the FIFO. If an error in the data format or in the CRC is detected, the MCU is alerted by an IRQ request with the Irq\_err bit set to high. Information about the cause for the error can be read from the *Interrupt register 2* (38h). In case of a reception error, the system still receives the expected number of bits, to maintain a similar time flow for the reader and the tags.

### Rx length register

Typically the expected reception length should be defined before the reception start. If this is not the case the reception length is updated during the reception when the actual length becomes available. When the reception is triggered at the end of normal data transmission (direct commands 90h, 91h, 92h), the reception length needs to be defined by the RXl[11:0] option bits in the *Rx length register 1* and *Rx length register 2* (3Ah, 3Bh).

For the direct Query commands (98h, 99h, 9Ah, 9Bh, 9Ch), the Rx length is predefined to 16 bits for the awaited RN16. For the direct command ReqRN (9Fh) the Rx length is internally set to 32 bits in order to receive handle and CRC. Only during the reception of the PC + EPC the reception length is not known in advance. To cover this case, the internal protocol logic checks the first received byte and adjusts the Rx length according to the value found in the first PC byte. In case reception is triggered manually by the direct command enable Rx (97h), the Rx length needs to be set by the RXl[11:0] option bits in the *Rx length register 1* and *Rx length register 2* (3Ah, 3Bh). If one of the AutoACK procedures is used, the Rx length is automatically set for all tag responses received during the automatic inventory command sequence.

If the automatically set Rx length does not fit the actual tag data length, possibly due to future protocol extensions or custom tag functionality, the MCU can change the expected Rx length during reception. In case of automatically set PC+EPC length, the length change is possible after the second received byte. The MCU can request an additional interrupt after



receiving two bytes (PC part of the PC + EPC field). The MCU can read out the two bytes that define the length of the on-going reception and update the Rx length register. The IRQ request after the 2nd byte is enabled by the `fifo_dir_irq2` option bit in the *Rx length register 1* (3Ah). The side effect of this mode is that CRC bytes become available in the FIFO as well. The actual reception of the second byte is signaled by the `Irq_2nd_byte` IRQ bit set to high in the *Interrupt register 1* (37h). If the actual Rx length is only available later, it is possible to extend the 2nd byte interrupt functionality to trigger additional IRQ requests after the 4th, 6th ... received byte by setting the `rep_irq2` option bit in the *Rx length register 1* (3Ah). When the interrupt after the targeted number of received bytes is received, clearing the `rep_irq2` option bit prevents extra interrupts for the rest of the reception.

For some Gen2 commands the tag can reply with a normal response or an error code. The two types of responses are different in length. For further MCU relief the `auto_errcode_RXI` option bit was prepared. When this option bit is set, the protocol logic checks the received header bit and adjusts its expected reception length to 41 bits (Gen2 error response length) if it detects an error code reception.

### RN16 register

In the EPC Class1 Gen2 protocol, the timing between a tag response and the subsequent reader command in the inventory round is relatively short. To help the MCU from reading the RN16 (or handle) from the FIFO and then writing it back to the FIFO, a special register for storing the last received RN16 is built into the device. The RN16 is stored after the last successful reception upon one of the direct Query commands. The last stored RN16 is automatically used in the ACK command.

### AutoACK modes

The AutoACK mode automatically performs the inventory command sequence for one transponder. The aim is relieve the MCU of time critical tasks by minimizing the number of interactions between the MCU and the reader device. The AutoACK mode is enabled by setting the `AutoACK[1:0]` option bits in the *Protocol selection register* (01h). Following modes are available:

- `AutoACK[1:0] = 00b`: Query only
- `AutoACK[1:0] = 01b`: Each query command is followed by an ACK
- `AutoACK[1:0] = 10b`: Each query command is followed by an ACK and ReqRN

The automatic inventory command sequence is triggered by the direct Query commands (98h, 99h, 9Ah, 9Bh, 9Ch). After successful RN16 reception, it automatically prepares and triggers the acknowledge command ACK and subsequent receptions. After successful reception of the PC+EPC, it automatically prepares and triggers the request for a handle (ReqRN) It also prepares the appropriate Rx length settings and provides the received data (PC+EPC, Handle) in the FIFO. The MCU reads out the baseband data and triggers next Query command to continue the inventory round or another tag command that can be used in tag open state.

The number of interrupts that need to be serviced by the host system (MCU) is minimized:

- Irq\_noresp is signaled if nothing is received.
- Irq\_fifo is signaled if EPC is longer than 18 bytes. It informs that data should be read out from the FIFO.
- Irq\_RX is signaled at the end of the EPC and Handle reception. This also tells that one AutoACK step is finished. Available data should be read out from the FIFO buffer if of no error.
- Irq\_AutoACK is signaled at the end of the AutoACK procedure, meaning that a RN16 was received and that at least the ACK command was issued during the sequence.
- Irq\_err is signaled if an error occurred during the procedure.

To successfully control the inventory round, the host system needs to distinguish between empty anti-collision slots and collided slots:

- Irq\_noresp without Irq\_AutoACK means that there was no response to a Query command. This presents a real empty slot in the inventory procedure.
- Irq\_noresp with Irq\_AutoACK or Irq\_err with Irq\_AutoACK means that RN16 was received, and that the empty slot or reception error happened later in the procedure. Probably some unidentified transponders are present in the field. But it could also mean that for particular settings and conditions, the filtered received noise level is above the digitizing hysteresis threshold and that the system recognizes it as tag signal.

The AutoACK function uses the *Rx no response time register* (07h) and *Rx wait time register* (08h) as they are used in other normal mode reception cases. An additional timer is used to define the T2 time according to the EPC Class1 Gen2 protocol. This time is defined in the *AutoACK wait time register* (06h). The timer is started at the end of the reception period and defines when the subsequent data transmission is triggered.

### Normal mode with test outputs

Following possibilities in the *Measurement control register* (10h) are available to observe operation in normal mode and during board debugging:

- Digitized sub-carrier signals of both receiving channels (I and Q) are enabled by setting the option bits Tcomb[1:0] = 01b. Outputs are OAD and OAD2.
- The Tx modulation output and the selected digitized sub-carrier signal channel are enabled by setting the option bits Tcomb[1:0] = 10b. Outputs are OAD (TX) and OAD2 (Rx).
- Analog sub-carrier signals of both receiving channels (I and Q) are enabled by setting the option bits e\_anaout[1:0] = 01b. Outputs are OAD and OAD2. Analog output has lower priority than the digital output.

## 2.10.2 Rx direct mode

Reception in the direct mode is triggered by setting the pin SCLK (enable Rx input) to high. When receiving data from a tag in direct mode, there are three possibilities depending on option bits setting:

- Internally decoded bit stream and bit clock according to the protocol is enabled by dir\_mode = 0 and defined by the option bits prot[2:0] in the *Protocol selection register*

(01h), RX\_cod[2:0] and RX\_LF[3:0] option bits in the *Rx options register* (03h). The outputs are the pins MISO and IRQ.

- Digitized sub-carrier signals of both receiving channels (I and Q) are enabled by setting the option bit dir\_mode in the *Protocol selection register* (01h) to high. The outputs are the pins MISO and IRQ.
- Analog sub-carrier signals of both receiving channels (I and Q) are enabled by setting the option bits e\_anaout[1:0] in the *Measurement control register* (10h) to 01b. The outputs are the pins OAD and OAD2.

For details on how to enter the direct mode and the re-assignments of the I/O pins in this mode refer to the [Section 2.8.2: TX direct mode](#).

### 2.10.3 Modes supporting tuning of antenna or directivity device

In order to achieve low reflected Tx power the user has to actively tune the antenna or the direct device. To enable correct tuning the amplitude and the phase information of the incoming reflected power is available through the output DC levels of the two mixers. The analog representation of the two mixer DC level outputs is available on the OAD and OAD2 outputs by setting e\_anaout[1:0] = 10b in the *Measurement control register* (10h). If the user does the tuning during reception, the Enable\_RX signal is required to know when the receiver is enabled. This information is available on ADC pin if Tcomb[1:0] = 11b in the *Measurement control register* (10h). Another approach to acquire the tuning data is to read the digital representation of the reflected power level as described in the A/D Converter section.

### 2.10.4 Logarithmic RSSI

The receiver section comprises two logarithmic RSSI (Received Signal Strength Indicator) blocks. They are connected to the outputs of both signal channels (I and Q). The value of each RSSI reading is stored during the data reception at the second received byte in the *RSSI display register* (2Bh) using r2Bpage[3:0] = 0110b. The RSSI result is valid until the start of the next transmission.

## 2.11 A/D converter

An 8-bit on board A/D converter supports an external power detector and can be connected to the internal diagnostic circuitry. The input range is  $\pm 1V$ , centered at the AGD voltage (1.6 V). The 7 LSBs give information about the absolute output level, while the MSB acts as a sign bit (while high indicates positive values, and low means negative values). The source for A/D conversion is selected through the msel[3:0] option bits in the *Measurement control register* (10h). The conversion is triggered by the direct command Trigger AD conversion (87h) and the result is available through the *ADC readout/regulator setting display register* (r2Dpage[1:0] = 00) (2Dh) using r2Dpage[1:0] = 00b (*Status readout page setting register*). The A/D conversion is finished after 20  $\mu s$  and an IRQ request is sent with the Irq\_cmd option bit set (*Interrupt register 2*).

### 2.11.1 External RF power detector

An external RF power detector can be placed after the PA or at the input coupled port of a directional coupler, making it possible to measure actual RF output power. The resulting analog voltage from the power detector can be connected to the ADC pin of the reader

device. The digital representation of this voltage level can be acquired with the on board A/D converter using `mself[3:0] = 0011b` (*Measurement control register*).

### 2.11.2 Reflected RF power indicator

The receiver comprises an input RF level indicator, used for diagnostic purposes of the circuitry or for detecting environmental difficulties around the antenna. Reflections from poor antennas (S11), the reflective antenna's environment and directional device leakage increase the carrier level (self-jammer level) at the mixer input. Since a higher carrier level causes an increase of demodulated noise, it is mandatory to keep the unwanted carrier level at the mixer input at a minimum. The reflected carrier that is seen on the two mixers inputs is down-converted to zero frequency. The two DC levels on the mixers outputs are proportional to the input RF level and can be used as a measure for the RF input level. The mixer DC levels are also dependent on the carrier input phase. The two mixer DC output levels can be connected to the on-board A/D converter by setting the option bits `mself[3:0] = 0001b` and `0010b`. The `id2x` and `id1x5` option bits adapt the gain of the reflected RF power level indicator.

### 2.11.3 Supply voltage measurement

The A/D converter can be also used to measure the supply voltages  $V_{EXT}$ ,  $V_{EXT\_PA}$ ,  $V_{DD\_B}$ , and  $V_{DD\_PA}$ . Depending on the conversion results the MCU can decide on the voltage regulator setting strategy. The selected voltage is connected to A/D converter input (VINPUT) by setting the option bit to `mself[3:0]`:

- `VEXT`: 0111b
- `VDD_B`: 1000 b
- `VEXT_PA`: 1001 b
- `VDD_PA`: 1010 b

The conversion is started by the direct command Trigger AD conversion (87h) and the result is available in the *ADC readout/regulator setting display register (r2Dpage[1:0] = 01)* (2Dh) using `r2Dpage[1:0] = 00b` (*Status readout page setting register*).

The conversion result is given by the equation:

$$\text{ADC register value} = \frac{(\text{Vinput} - 1.6) \cdot 0.8 - 1.6}{0.0079}$$

where the ADC register value is the value in register 2Dh and  $V_{input}$  is the analog voltage present at the A/D converter input in volts.

### 2.11.4 Linear RSSI with sub-carrier phase bit

The demodulated peak-to-peak voltages of both signal channels (I and Q) are connected to a double sample and hold circuit and are sampled at the end of the tag-preamble (pilot tone). They can be A/D converted during or after the reception. The MCU can convert and read out the two voltages using the internal linear A/D converter by setting the option bits `mself[3:0] = 1011b` and `mself[3:0] = 1100b` (*Measurement control register*) and triggering the conversion by the direct command Trigger AD conversion (87h). The results are available in

the *ADC readout/regulator setting display register (r2Dpage[1:0] = 01)* (2Dh) using r2Dpage[1:0] = 00b (*Status readout page setting register*). For the linear RSSI, the sampled voltages are shifted to use the whole ADC range. The minimum sample value gives -127 as ADC result, and the maximum sample value gives +127 as ADC result. The status bit *subc\_phase* in the *AGC and internal status display register (2Ah)* shows whether the two sampled peak-to-peak voltages (I and Q) were in phase or in anti-phase at the moment of sampling. The phase bit is valid from the end of pilot tone till the end of reception and should be read out before the end of reception. Using the linear (absolute) I and Q RSSI values and the phase bit information the systems allows detecting the RSSI phase information within.

### 2.11.5 Internal signal level detectors

An internal signal level detector is placed at the output of the internal VCO and therefore enables the measurement of the internal RF carrier level. The selected source is connected to the A/D converter input through the option bits *msel[3:0] = 0100b*. For a description of the conversion procedure refer to the A/D converter description. The internal signal level detector is meant for diagnostic purposes only and should not be used for measurement of the output power.

## 2.12 Interrogator anti-collision support

To enable the ISO 29143 functionality, a RSSI based interrogator anti-collision support is arranged. The feature is enabled by the direct command Interrogator anti-collision support enable (AAh). According to the ISO 29143 proposal, the system monitors the RSSI envelope of the received sub-carrier signals and informs the MCU in case at least in a part of the received data packet the RSSI level has exceeded the predefined threshold. It also stores RSSI and timing data of the data packet at relevant points.

Following RSSI values are stored:

- RSSI at pilot tone
- RSSI at data
- Maximum RSSI value in the telegram

Following timing data are stored:

- First time at which the predefined threshold was exceed
- Threshold exceedance duration
- Time of first protocol violation

Time is related to the received bits.

The predefined collision detection threshold is in the *ICD\_Th[3:0]* bits in the *Interrogator collision detection and IQ selection settings register (1Dh)*. To enable the functionality the direct command Interrogator anti-collision support enable (AAh) needs to be sent. To disable it the Interrogator anti-collision support disable (ABh) direct command should be used. To clear the peak RSSI value and timing data again use the Interrogator anti-collision support disable (ABh) direct command.

### 3 Register description

The 6-bit long register addresses are shown in the hexadecimal notation. There are two types of registers implemented in the reader device:

- Read/Write registers
- Read-only display registers.

They can be accessed via the serial interface.

**Table 9. Registers map**

Address (hex)	Main function	Content	Type
00	Main control	<i>Device status control register</i>	RW
01		<i>Protocol selection register</i>	RW
02	Configuration	<i>Tx options register</i>	RW
03		<i>Rx options register</i>	RW
04		<i>TRcal high register</i>	RW
05		<i>TRcal low register</i>	RW
06		<i>AutoACK wait time register</i>	RW
07		<i>Rx no response time register</i>	RW
08		<i>Rx wait time register</i>	RW
09		<i>Rx filter setting register</i>	RW
0A		<i>Rx mixer and gain register</i>	RW
0B		<i>Regulator and PA bias register</i>	RW
0C		<i>RF output and LO control register</i>	RW
0D		<i>Miscellaneous register 1</i>	RW
0E		<i>Miscellaneous register 2</i>	RW
10		<i>Measurement control register</i>	RW
11		<i>VCO control register</i>	RW
12		<i>CP control register</i>	RW
13		<i>Modulator control register 1</i>	RW
14		<i>Modulator control register 2</i>	RW
15		<i>Modulator control register 3</i>	RW
16		<i>Modulator control register 4</i>	RW
17	<i>PLL main register 1</i>	RW	
18	<i>PLL main register 2</i>	RW	
19	<i>PLL main register 3</i>	RW	
1A	<i>PLL auxiliary register 1</i>	RW	
1B	<i>PLL auxiliary register 2</i>	RW	

Table 9. Registers map (continued)

Address (hex)	Main function	Content	Type
1C	Configuration	<i>PLL auxiliary register 3</i>	RW
1D		<i>Interrogator collision detection and IQ selection settings register</i>	RW
22		<i>Emitter-coupled mixer options register</i>	RW
29	Status	<i>Status readout page setting register</i>	RW
2A		<i>AGC and internal status display register</i>	R
2B		<i>RSSI display register</i>	R
2C		<i>AGL/VCO/F_CAL/PilotFreq status display register (r2Cpage[1:0] = 00)</i>	R
		<i>AGL/VCO/F_CAL/PilotFreq status register (r2Cpage[1:0] = 01)</i>	R
2D		<i>ADC readout/regulator setting display register (r2Dpage[1:0] = 00)</i>	R
2E		<i>Command status display register</i>	R
33		<i>Version register</i>	R
35		Interrupt	<i>Enable interrupt register 1</i>
36	<i>Enable interrupt register 2</i>		RW
37	<i>Interrupt register 1</i>		R
38	<i>Interrupt register 2</i>		R
39	Communication	<i>FIFO status register</i>	R
3A		<i>Rx length register 1</i>	RW
3B		<i>Rx length register 2</i>	RW
3C		<i>Tx setting register</i>	RW
3D		<i>Tx length register 1</i>	RW
3E		<i>Tx length register 2</i>	RW
3F		<i>FIFO I/O register</i>	T <sub>x</sub> : W R <sub>x</sub> : R

In the register description tables the bit names along with their default value after device power-up (EN=L). A short function description and comment are given.

### 3.1 Main control registers

In the Register Description tables the bit names along with their default value after device power-up (EN = L). A short function description and comment are given.

### 3.1.1 Device status control register

Address: 00h

Type: RW

Table 10. Device status control register

Bit	Name	Default	Function	Comments
7	stby	0	Stand-by mode	0: Normal mode 1: Standby mode
6	RFU	0	Not used	RFU, do not set
5	RFU	0	Not used	RFU, do not set
4	RFU	0	Not used	RFU, do not set
3	RFU	0	Not used	RFU, do not set
2	agc_on	0	AGC enable	0: AGC OFF 1: AGC ON
1	rec_on	0	Receiver enable	0: The receiver is disabled 1: The receiver is enabled
0	rf_on	0	Transmitter and receiver enable	0: Tx RF field and receiver are disabled 1: Tx RF field and receiver are enabled

### 3.1.2 Protocol selection register

Address: 01h

Type: RW

Table 11. Protocol selection register

Bit	Name	Default	Function	Comments
7	RX_crc_n	0	Receiving without CRC	0: Rx with CRC 1: Rx without CRC
6	dir_mode	0	Decoder mode type	0: Normal operation 1: Disables any decoding and signal sensing automatics in the receiver. It is advised to set this bit high when continuous analog measurements are performed.
5	AutoACK[1]	0	AutoAck mode	00: No Auto ACK 01: AutoACK 10: AutoACK+ReqRN 11: RFU, do not set
4	AutoACK[0]	0		
3	RFU	0	Not used	RFU, do not set
2	prot[2]	0	Protocol selection	000: EPC Class1 Gen2/ISO18000-6C 001: ISO18000-6 Type A/B direct mode decoder enable Others: RFU, do not set
1	prot[1]	0		
0	prot[0]	0		



## 3.2 Configuration registers

### 3.2.1 Tx options register

Address: 02h

Type: RW

**Table 12. Tx options register**

Bit	Name	Default	Function	Comments
7	RFU	0	Not used	RFU, do not set
6	RFU	0	Not used	RFU, do not set
5	TXOne[1]	1	Tx one length control	00: 1.50 * Tari
4	TXOne[0]	1		01: 1.66 * Tari 10: 1.83 * Tari 11: 2.00 * Tari
3	RFU	0	Not used	RFU, do not set
2	Tari[2]	0	Tari definition	000: Tari = 6.25 $\mu$ s
1	Tari[1]	1		001: Tari = 12.5 $\mu$ s
0	Tari[0]	0		010: Tari = 25 $\mu$ s Others: RFU, do not set

### 3.2.2 Rx options register

Address: 03h

Type: RW

**Table 13. Rx options register**

Bit	Name	Default	Function	Comments
7	RX_LF[3]	1	Link frequency	0000: 40 kHz
6	RX_LF[2]	1		0110: 160 kHz
5	RX_LF[1]	0		1001: 250 kHz
4	RX_LF[0]	0		1100: 320 kHz 1111: 640 kHz Other: RFU, do not set
3	TRExt	1	Rx preamble length	0: Short preamble 1: Long preamble Short preamble is supported for Miller 4 and Miller 8 coding.
2	RX_cod[2]	0	Rx coding	000: FM0
1	RX_cod[1]	1		001: M2
0	RX_cod[0]	0		010: M4 011: M8 Other: RFU, do not set

### 3.2.3 TRcal high register

Address: 04h

Type: RW

Table 14. TRcal high register

Bit	Name	Default	Function	Comments
7	low_vsp_lo	0	low_vsp_lo	1: Adaptation to low supply for the LO phase shifter
6	id2x	0	id2x	Adapt gain 2x of the reflected RF power level (mixer DC level) indicator
5	id1x5	0	id1x5	Adapt gain 1.5x of the reflected RF power level (mixer DC level) indicator
4	RFU		Not used	RFU, do not set
3	TRcal[11]	0	TRcal[11:0] bits define TRcal time	Description in register 05h
2	TRcal[10]	0		
1	TRcal[9]	1		
0	TRcal[8]	0		

### 3.2.4 TRcal low register

Address: 05h

Type: RW

Table 15. TRcal low register

Bit	Name	Default	Function	Comments
7	TRcal[7]	1	TRcal[11:0] bits define TRcal time	Range: 0.1 $\mu$ s - 409 $\mu$ s Steps: 4096 Step size: 0.1 $\mu$ s Worst case relative resolution in Gen 2 range: $\frac{0.1 \mu\text{s}}{17.2 \mu\text{s}} \approx 0.6 \%$ Gen2 defines a range from 17.2 $\mu$ s to 225 $\mu$ s
6	TRcal[6]	0		
5	TRcal[5]	0		
4	TRcal[4]	1		
3	TRcal[3]	1		
2	TRcal[2]	0		
1	TRcal[1]	1		
0	TRcal[0]	1		

### 3.2.5 AutoACK wait time register

Address: 06h

Type: RW

**Table 16. AutoACK wait time register**

Bit	Name	Default	Function	Comments
7	Auto_T2[7]	0	EPC protocol time T2 according to EPC C1 Gen2	Time used in the AutoACK procedure. Range: 0 – 816 $\mu$ s Step size: 3.2 $\mu$ s.
6	Auto_T2[6]	0		
5	Auto_T2[5]	0		
4	Auto_T2[4]	0		
3	Auto_T2[3]	0		
2	Auto_T2[2]	1		
1	Auto_T2[1]	0		
0	Auto_T2[0]	0		

### 3.2.6 Rx no response time register

Address: 07h

Type: RW

**Table 17. Rx no response time register**

Bit	Name	Default	Function	Comments
7	NoResp[7]	0	Defines the timeout after which the no response interrupt is sent. It starts at the end of Tx.	Step size: 25.6 $\mu$ s Range: 25.6 $\mu$ s – 6502 $\mu$ s (1 - 254). 255: No response time: 26.2 ms. Interrupt is sent if the time runs out before 6 - 10 periods of link frequency (tag preamble) are detected. T1 = 25.6 $\mu$ s - 262 $\mu$ s. Default = 15 * 25.6 $\mu$ s = 384 $\mu$ s. Gen2 Write command: 20 ms max.
6	NoResp[6]	0		
5	NoResp[5]	0		
4	NoResp[4]	0		
3	NoResp[3]	1		
2	NoResp[2]	1		
1	NoResp[1]	1		
0	NoResp[0]	1		

### 3.2.7 Rx wait time register

Address: 08h

Type: RW

Table 18. Rx wait time register

Bit	Name	Default	Function	Comments
7	RXw[7]	0	Rx wait time. Defines the time during which the Rx input is ignored. It starts from the end of Tx.	Step size: 6.4 $\mu$ s Range: 6.4 $\mu$ s – 1632 $\mu$ s (1 - 255), 00h: The receiver is enabled immediately after Tx Gen2: T1min = 11.28 $\mu$ s - 262 $\mu$ s. ISO1800-6A: 150 $\mu$ s - 1150 $\mu$ s ISO1800-6B: 85 $\mu$ s - 460 $\mu$ s Default = 7 * 6.4 $\mu$ s = 44.8 $\mu$ s.
6	RXw[6]	0		
5	RXw[5]	0		
4	RXw[4]	0		
3	RXw[3]	0		
2	RXw[2]	1		
1	RXw[1]	1		
0	RXw[0]	1		

### 3.2.8 Rx filter setting register

Address: 09h

Type: RW

Table 19. Rx filter setting register

Bit	Name	Default	Function	Comments
7	byp2	0	bypass 2	Set to FFh: 40 kHz link frequency
6	byp1	0	bypass 1	
5	lp[3]	1	Low pass setting	
4	lp[2]	0		
3	lp[1]	0		
2	hp[3]	1	High pass setting	
1	hp[2]	0		
0	hp[1]	0		

### 3.2.9 Rx mixer and gain register

Address: 0Ah

Type: RW

Table 20. Rx mixer and gain register

Bit	Name	Default	Function	Comments
7	gain[5]	0	Baseband gain change	Steps: 4 Step Size: 3 dB 00: 0 dB 11: 9 dB Increase/decrease defined by gain_sign option bit
6	gain[4]	0		
5	gain_sign	0	Sign bit for BB gain settings (gain[5:4])	0: Decrease baseband gain 1: Increase baseband gain
4	gain[2]	0	Digitizer hysteresis increase	Steps: 5 Step Size: 3 dB 000: 0 dB 100: 12 dB Other: RFU, do not set
3	gain[1]	0		
2	gain[0]	0		
1	mix_ir[1]	0	Mixer gain and input range selection	Differential Rx mixer: – 00: Nominal gain – 01: 8 dB attenuation – 10: 10 dB gain increase Single ended Rx mixer: – 00: 6 dB mixer gain decrease – 01: Nominal gain – 11: 6 dB mixer gain increase
0	mix_ir[0]	1		

### 3.2.10 Regulator and PA bias register

Address: 0Bh

Type: RW

Table 21. Regulator and PA bias register

Bit	Name	Default	Function	Comments
7	pa_bias[1]	0	Increase internal PA bias	1: Increase bias four times
6	pa_bias[0]	0	Increase internal PA bias	1: Increase bias two times
5	rvs_rf[2]	0	V <sub>DD_PA</sub> regulator voltage settings	Manual settings: Steps equal to rvs[2:0] For correct operation the regulator voltage drop should be 300 mV or more. Min: 000b: 2.7 V Max: 111b: 3.4 V Steps: 8 Step size: 0.1 V Automatic setting: Output voltage results from the target voltage drop defined by rvs[2:0] or by manual settings rvs_rf[2:0], whichever yields lower output voltage automatic mode is triggered by the direct command (A2h).
4	rvs_rf[1]	1		
3	rvs_rf[0]	1		
2	rvs[2]	0		
1	rvs[1]	1	Other regulators voltage setting	Manual setting: For correct operation the regulator voltage drop should be 300 mV or more. Min: 000 <sub>b</sub> : 2.7 V Max: 111 <sub>b</sub> : 3.4 V Steps: 8 Step size: 0.1 V Automatic setting: 001 <sub>b</sub> : Target voltage drop > 250 mV, 011 <sub>b</sub> : Target voltage drop > 300 mV, 111 <sub>b</sub> : Target voltage drop > 350 mV. automatic mode is triggered by the direct command (A2 <sub>h</sub> ).
0	rvs[0]	1		

### 3.2.11 RF output and LO control register

Address: 0Ch

Type: RW

Table 22. RF output and LO control register

Bit	Name	Default	Function	Comments
7	eTX[7]	0	LO (local oscillator) gain	0: Nominal 1: 6 dB gain in LO path
6	eTX[6]	0	LO source selection	0: LO source is RFOPX, RFONX 1: LO source is pre-driver for the internal PA
5	eTX[5]	0	Enable internal $V_{DD\_PA}$ voltage regulator	$V_{DD\_PA}$ regulator is automatically enabled if the internal PA is enabled via eTX[3:2]
4	RFU	0	Not used	RFU, do not set
3	eTX[3]	0	Main PA enable and bias current for main PA pre-driver	00: Disable 01: 7 mA 10: 14 mA 11: 22 mA
2	eTX[2]	0		
1	eTX[1]	1	Enable RF low-power output and bias current for RF output stage.	00: Disable 01: 7 mA 10: 14 mA (default) 11: 22 mA
0	eTX[0]	0		

### 3.2.12 Miscellaneous register 1

Address: 0Dh

Type: RW

Table 23. Miscellaneous register 1

Bit	Name	Default	Function	Comments
7	hs_output	1	Strong, fast communication output drivers	Valid for MISO, IRQ, CLSYS
6	hs_oad	0	Strong, fast test output drivers	Valid for OAD, OAD2, ADC
5	miso_pd2	0	Pull down resistor: NCS = 0	1: Enable a pull down resistor on MISO, when NCS is low and MISO is not driven by the ST25RU3993
4	miso_pd1	0	Pull down resistor: NCS = 1	1: Enable a pull down resistor on MISO when NCS is high
3	open_dr	0	Open drain N-MOS outputs	Valid for MISO, IRQ, CLSYS

Table 23. Miscellaneous register 1 (continued)

Bit	Name	Default	Function	Comments
2	s_mix	0	Single-ended mixer input enable	0: Differential input 1: Single ended input
1	RFU	0	Not used	RFU, do not set
0	RFU	0	Not used	RFU, do not set

### 3.2.13 Miscellaneous register 2

Address: 0Eh

Type: RW

Table 24. Miscellaneous register 2

Bit	Name	Default	Function	Comments
7	xosc[1]	0	Reference frequency oscillator mode selection	00: Normal operation with auto power saving mode 01: External sinus TCXO AC coupled to OSCO 10: Disable auto power saving mode 11: RFU, do not set
6	xosc[0]	0		
5	RFU	0	Not used	RFU, do not set
4	RFU	0	Not used	RFU, do not set
3	f_cal_hp_chg	0	Change the Rx filter calibration	1: Enables changing the hp calibration 0: Enables changing the lp calibration Use direct commands: Decrease Rx Filter Calibration Data (89 <sub>h</sub> ) Increase Rx Filter Calibration Data (8A <sub>h</sub> ).
2	clsys[2]	1	CLSYS output frequency	000: Off 100: 4 MHz 001: 5 MHz 010: 10 MHz 011: 20 MHz Others: RFU, do not set
1	clsys[1]	0		
0	clsys[0]	0		



### 3.2.14 Measurement control register

Address: 10h

Type: RW

Table 25. Measurement control register

Bit	Name	Default	Function	Comments
7	Tcomb[1]	0	Digital test output modes	00: Disable 01: Digitized Rx sub-carriers outputs on OAD, OAD2 10: Tx modulation and selected Rx sub-carrier outputs on OAD, OAD2 11: Enable Rx output on ADC
6	Tcomb[0]	0		
5	e_anaout[1]	0	Analog test output modes	00: Disable 01: Analog sub-carrier out on OAD, OAD2 10: Analog mixer DC output on OAD, OAD2 11: RFU, do not set
4	e_anaout[0]	0		
3	mssel[3]	0	ADC measurement selection	0001: Mixer DC level I-channel 0010: Mixer DC level Q-channel 0011: ADC pin 0100: Internal RF level 0111: V <sub>EXT</sub> level 1000: V <sub>DD_B</sub> level 1001: V <sub>EXT_PA</sub> level 1010: V <sub>DD_PA</sub> level 1011: RSSI I level 1100: RSSI Q level 1111: RFOPX, RFONX power level 0000: NC
2	mssel[2]	0		
1	mssel[1]	0		
0	mssel[0]	0		

### 3.2.15 VCO control register

Address: 11h

Type: RW

Table 26. VCO control register

Bit	Name	Default	Function	Comments
7	mvco	0	VCO measurement enable	Steps: 7 Result in register 2Ch r2Cpage[1:0] = 01
6	eosc[2]	1	Internal oscillator bias current	8 steps, Step size: 0.52 mA 000: Minimum bias current (~1.3 mA) 111: Maximum bias current (~5 mA)
5	eosc[1]	0		
4	eosc[0]	0		

Table 26. VCO control register (continued)

Bit	Name	Default	Function	Comments
3	vco_r[3]	0	Manual VCO range selection	Manual selection of the VCO range segment
2	vco_r[2]	0		
1	vco_r[1]	0		
0	vco_r[0]	0		

### 3.2.16 CP control register

Address: 12h

Type: RW

Table 27. CP control register

Bit	Name	Default	Function	Comments
7	LF_R3[7]	0	Loop filter R3-selection	00: 30 k $\Omega$ (default)
6	LF_R3[6]	0		01: 50 k $\Omega$ 10: 70 k $\Omega$ 11: 100 k $\Omega$
5	LF_C3[5]	0	Loop filter C3-selection	000: 20 pF (default)
4	LF_C3[4]	0		001: 40 pF 010: 60 pF 011: 80 pF
3	LF_C3[3]	0		100: 100 pF 101: 130 pF 110: 160 pF 111: 200 pF
2	cp[2]	1		Charge pump current
1	cp[1]	0	001: 300 $\mu$ A 010: 600 $\mu$ A 011: 1200 $\mu$ A	
0	cp[0]	0	100: 1350 $\mu$ A (default)	
			101: 1500 $\mu$ A 110: 1800 $\mu$ A 111: 2350 $\mu$ A	

### 3.2.17 Modulator control register 1

Address: 13h

Type: RW

**Table 28. Modulator control register 1**

Bit	Name	Default	Function	Comments
7	RFU	0	Not used	RFU, do not set
6	main_mod	0	Modulation connected to high power output	Enables the modulation of the high power outputs.
5	aux_mod	1	Modulation connected to low-power output	Enables the modulation of the low-power outputs.
4	RFU	0	Not used	RFU, do not set
3	RFU	0	Not used	RFU, do not set
2	e_lpf	0	Enable low pass filter for the modulation signal	To further smooth the modulation signal
1	ask_rate[1]	0	ASK modulation transient rate change.	00: Tari determined 01: Use every 2 <sup>nd</sup> modulator value. 10: Use every 4 <sup>th</sup> modulator value. 11: Use every 8 <sup>th</sup> modulator value.
0	ask_rate[0]	0		

### 3.2.18 Modulator control register 2

Address: 14h

Type: RW

**Table 29. Modulator control register 2**

Bit	Name	Default	Function	Comments
7	ook_ask	1	100% ASK enable with variable delimiter length and delimiter shape selection	Delimiter shape if pr_ask = 1: <ul style="list-style-type: none"> <li>Tari = 25 <math>\mu</math>s:                             <ul style="list-style-type: none"> <li>0: PR-ASK shaped delimiter transient</li> <li>1: ASK shaped delimiter transient</li> </ul> </li> <li>Tari = 6.25 <math>\mu</math>s or 12.5 <math>\mu</math>s:                             <ul style="list-style-type: none"> <li>ASK shaped delimiter transient (regardless of this bit setting)<sup>(1)</sup>.</li> </ul> </li> </ul> Delimiter shape if pr_ask = 0: ook_ask should be set to 1, 100% ASK shaped delimiter transient
6	pr_ask	0	PR-ASK enable	Enables PR-ASK Tx modulation. If this bit is set to low ASK modulation is used.
5	del_len[5]	0	ASK / PR-ASK delimiter length adjustment	Adjust delimiter length. Range: 9.6 $\mu$ s to 15.9 $\mu$ s. Step size: 0.1 $\mu$ s. Default 1D = 12.5 $\mu$ s.
4	del_len[4]	1		
3	del_len[3]	1		
2	del_len[2]	1		
1	del_len[1]	0		
0	del_len[0]	1		

1. The Tx spectrum is not affected to a visible level due to ASK delimiter transient

### 3.2.19 Modulator control register 3

Address: 15h

Type: RW

**Table 30. Modulator control register 3**

Bit	Name	Default	Function	Comments
7	trfon[1]	0	RF ON/OFF transition time	00: Tari determined
6	trfon[0]	0		01: 100 $\mu$ s 10: 200 $\mu$ s 11: 400 $\mu$ s
5	lin_mod	0	Selects linear modulation transient	1: Linear modulation transient 0: Sinusoidal shaped modulation transient
4	TX_lev[4]	0	Tx output level coarse adjustment. For low and high power outputs	00: 0 dB, nominal
3	TX_lev[3]	0		01: -8 dB 10: -12 dB 11: RFU, do not set

Table 30. Modulator control register 3 (continued)

Bit	Name	Default	Function	Comments
2	TX_lev[2]	0	Tx output level fine adjustment. For low and high power outputs	000: Nominal 001: -1 dB 111: -7 dB Step size: -1 dB
1	TX_lev[1]	0		
0	TX_lev[0]	0		

### 3.2.20 Modulator control register 4

Address: 16h

Type: RW

Table 31. Modulator control register 4

Bit	Name	Default	Function	Comments
7	1stTari[7]	0	1 <sup>st</sup> Tari high period length	Adjust 1st Tari high period following the delimiter Range: 5Fh - 9Dh, Step size: – 50ns (Tari = 6.25 $\mu$ s) – 100ns (Tari = 12.5 $\mu$ s) – 200ns (Tari = 25 $\mu$ s)
6	1stTari[6]	1		
5	1stTari[5]	1		
4	1stTari[4]	1		
3	1stTari[3]	1		
2	1stTari[2]	1		
1	1stTari[1]	1		
0	1stTari[0]	0		

### 3.2.21 PLL main register 1

Address: 17h

Type: RW

Table 32. PLL main register 1

Bit	Name	Default	Function	Comments
7	RFU	0	Not used	RFU, do not set
6	RefFreq[2]	1	PLL reference divider	100: 125 kHz 101: 100 kHz 110: 50 kHz 111: 25 kHz Others: RFU, do not set
5	RefFreq[1]	1		
4	RefFreq[0]	0		

**Table 32. PLL main register 1 (continued)**

Bit	Name	Default	Function	Comments
3	mB_val[9]	0	PLL main divider, value B, MSB part	A and B values for the 32/33 Prescaler Dividing ratio: $N = B \cdot 32 + A \cdot 33$ Proposed A/B ratio: $\frac{1}{3} \dots 3$ Example: A value: 134d (86h) B value: 404d (194h) N = 17350 PLL reference divider = 50 kHz Carrier frequency = 867.5 MHz
2	mB_val[8]	1		
1	mB_val[7]	0		
0	mB_val[6]	0		

**3.2.22 PLL main register 2**

Address: 18h

Type: RW

**Table 33. PLL main register 2**

Bit	Name	Default	Function	Comments
7	mB_val[5]	0	PLL main divider, value B, LSB part	see <a href="#">PLL main register 1</a> comments
6	mB_val[4]	1		
5	mB_val[3]	1		
4	mB_val[2]	0		
3	mB_val[1]	1		
2	mB_val[0]	0		
1	mA_val[9]	0	PLL main divider value A, MSB part	
0	mA_val[8]	0		

### 3.2.23 PLL main register 3

Address: 19h

Type: RW

Table 34. PLL main register 3

Bit	Name	Default	Function	Comments
7	mA_val[7]	1	PLL main divider value A, LSB part	see <a href="#">PLL main register 1</a> comments
6	mA_val[6]	1		
5	mA_val[5]	1		
4	mA_val[4]	1		
3	mA_val[3]	1		
2	mA_val[2]	1		
1	mA_val[1]	0		
0	mA_val[0]	0		

### 3.2.24 PLL auxiliary register 1

Address: 1Ah

Type: RW

Table 35. PLL auxiliary register 1

Bit	Name	Default	Function	Comments
7	RFU	0	Not used	RFU, do not set
6	RFU	0		
5	RFU	0		
4	RFU	0		
3	xB_val[9]	0	PLL auxiliary divider value B, MSB part	A and B values for the 32/33 Prescaler Dividing ratio: $N = B \cdot 32 + A \cdot 33$ Proposed A/B ratio: $\frac{1}{3} \dots 3$ Example: A value: 134d (86h) B value: 404d (194h) N = 17350 PLL reference divider = 50 kHz Carrier frequency = 867.5 MHz
2	xB_val[8]	1		
1	xB_val[7]	0		
0	xB_val[6]	0		

### 3.2.25 PLL auxiliary register 2

Address: 1Bh

Type: RW

Table 36. PLL auxiliary register 2

Bit	Name	Default	Function	Comments
7	xB_val[5]	0	PLL auxiliary divider, value B, LSB part	See register <a href="#">PLL auxiliary register 1</a>
6	xB_val[4]	1		
5	xB_val[3]	1		
4	xB_val[2]	0		
3	xB_val[1]	0		
2	xB_val[0]	0		
1	xA_val[9]	0	PLL auxiliary divider value A, MSB part	
0	xA_val[8]	1		

### 3.2.26 PLL auxiliary register 3

Address: 1Ch

Type: RW

Table 37. PLL auxiliary register 3

Bit	Name	Default	Function	Comments
7	xA_val[7]	0	PLL auxiliary divider, value A, LSB part	See register <a href="#">PLL auxiliary register 2</a>
6	xA_val[6]	0		
5	xA_val[5]	0		
4	xA_val[4]	1		
3	xA_val[3]	1		
2	xA_val[2]	0		
1	xA_val[1]	0		
0	xA_val[0]	0		



### 3.2.27 Interrogator collision detection and IQ selection settings register

Address: 1Dh

Type: RW

**Table 38. Interrogator collision detection and IQ selection settings register**

Bit	Name	Default	Function	Comments
7	IQsel_Th[3]	0	Threshold for IQ selection	Supports signal channel selection by the logarithmic RSSI measurement. RSSI will be taken into account if at least one RSSI reading (I or Q) is higher than defined by this threshold setting.
6	IQsel_Th[2]	0		
5	IQsel_Th[1]	0		
4	IQsel_Th[0]	0		
3	ICD_Th[3]	0	Threshold for ICD selection	Sets the collision detection RSSI threshold for the ISO 29143 protocol.
2	ICD_Th[2]	0		
1	ICD_Th[1]	0		
0	ICD_Th[0]	0		

### 3.2.28 Emitter-coupled mixer options register

Address: 22h

Type: RW

**Table 39. Emitter-coupled mixer options register**

Bit	Name	Default	Function	Comments
7	ic_bia_m[1]	0	Decrease device bias	00: Nominal 01: bias -3 % 10: bias -6 % 11: bias -9 %
6	ic_bia_m[0]	0		
5	iadd_sink[2]	0	Mixer sink current adjustment	select mixer load stage current
4	iadd_sink[1]	0		
3	iadd_sink[0]	0		
2	emix_vr[2]	0	sr2	Single ended Rx mixer: – sr2, sr1, sr0: Select mixer input voltage range
1	emix_vr[1]	0	sr1	
0	emix_vr[0]	0	sr0	

### 3.3 Status registers

#### 3.3.1 Status readout page setting register

Address: 29h

Type: RW

Table 40. Status readout page setting register

Bit	Name	Default	Function	Comments
7	r2Dpage[1]	0	Register page selection for register 2Dh	Defines actual display of <i>ADC readout/regulator setting display register (r2Dpage[1:0] = 01)</i>
6	r2Dpage[0]	0		
5	r2Cpage[1]	0	Register page selection for register 2Ch	Defines actual display of <i>AGL/VCO/F_CAL/PilotFreq status register (r2Cpage[1:0] = 01)</i>
4	r2Cpage[0]	0		
3	r2Bpage[3]	0	Register page selection for register 2Bh	0000: Real time RSSI I,Q 0010 : RSSI-0-quiet (noise RSSI), I,Q Quiet level- Acquired by direct command Store RSSI (A8h) 0100: RSSI-1-pilot, I,Q Level at pilot 0110: RSSI-2-data, I,Q Level at 2nd byte 1000: RSSI-3-peak, I, Q Peak Level 1100: IDC-Time - Time at exceeding threshold. 1101: IDC-Length - Threshold exceeding duration. 1110: Err-Time - Time at first protocol violation. Time is in terms of received bits. Others: not used
2	r2Bpage[2]	0		
1	r2Bpage[1]	0		
0	r2Bpage[0]	0		

#### 3.3.2 AGC and internal status display register

Address: 2Ah

Type: R

Table 41. AGC and internal status display register

Bit	Name	Function	Comments
7	subc_phase	Sub-carrier phase	0: Sub-carriers are in anti-phase 1: Sub-carriers are in phase
6	agc[2]	AGC status	Steps: 7 Step size: 3 dB
5	agc[1]		
4	agc[0]		
3	in_select	Shows the source of the sub-carrier signal that is used for decoding	0: I-Channel 1: Q-Channel Value is valid from reception start until the start of the next transmission

Table 41. AGC and internal status display register (continued)

Bit	Name	Function	Comments
2	rf_ok	RF level stable	Indicates that the RF carrier is stable
1	pll_ok	PLL locked	Indicates that PLL is locked to the RF carrier
0	osc_ok	Crystal oscillator stable	Indicates that the reference oscillator frequency is stable

### 3.3.3 RSSI display register

Address: 2Bh

Type: R

Table 42. RSSI display register

Bit	Name	Function	Comments
7	rssi[7]	RSSI value of Q channel. The RSSI type defined in <i>AGC and internal status display register</i> , bits r2Bpage[3:0].	Displays the signal strength of the Q signal channel Steps: 16 Step size: 2 dB
6	rssi[6]		
5	rssi[5]		
4	rssi[4]		
3	rssi[3]	RSSI value of I channel. The RSSI type defined in <i>Status readout page setting register</i> , bits r2Bpage[3:0].	Displays the signal strength of the I signal channel Steps: 16 Step size: 2 dB
2	rssi[2]		
1	rssi[1]		
0	rsss[0]		

### 3.3.4 AGL/VCO/F\_CAL/PilotFreq status display register (r2Cpage[1:0] = 00)

Address: 2Ch, r2Cpage[1:0] = 00

Type: R

Table 43. AGL/VCO/F\_CAL/PilotFreq status display register (r2Cpage[1:0] = 00)

Bit	Name	Function	Comments
7	RFU	Not used	Status bit, read as 0
6	RFU	Not used	Status bit, read as 0
5	agl[5]	AGL status of Q channel	Available steps are 0, 1, 2, 3, 4 Step size: 3 dB
4	agl[4]		
3	agl[3]		
2	agl[2]	AGL status of I channel	Range: 0 dB – 12 dB Steps 5, 6, 7 have no action
1	agl[1]		
0	agl[0]		

### 3.3.5 AGL/VCO/F\_CAL/PilotFreq status register (r2Cpage[1:0] = 01)

Address: 2Ch, r2Cpage[1:0] = 01

Type: R

**Table 44. AGL/VCO/F\_CAL/PilotFreq status register (r2Cpage[1:0] = 01)**

Bit	Name	Function	Comments
7	vco_ri[7]	VCO automatic range select result	Displays the result of the internal VCO automatic range selection procedure. Steps: 16
6	vco_ri[6]		
5	vco_ri[5]		
4	vco_ri[4]		
3	vco_ri[3]	Set to logic 1	RFU, read as 1
2	vco_ri[2]	VCO pin voltage measurement result	Displays the result of the internal VCO measurement. Steps: 7 Range: 0 V to V <sub>DD_A</sub>
1	vco_ri[1]		
0	vco_ri[0]		

### 3.3.6 AGL/VCO/F\_CAL/PilotFreq status register (r2Cpage[1:0] = 10)

Address: 2Ch, r2Cpage[1:0] = 10

Type: R

**Table 45. AGL/VCO/F\_CAL/PilotFreq status register (r2Cpage[1:0] = 10)**

Bit	Name	Function	Comments
7	hp_cal[3]	High pass calibration data	Steps: 16 Step size: 4%
6	hp_cal[2]		
5	hp_cal[1]		
4	hp_cal[0]		
3	lp_cal[3]	Low pass calibration data	Steps: 16 Step size: 4%
2	lp_cal[2]		
1	lp_cal[1]		
0	lp_cal[0]		

### 3.3.7 ADC readout/regulator setting display register (r2Dpage[1:0] = 00)

Address: 2Dh, r2Dpage[1:0] = 00

Type: R

**Table 46. ADC readout/regulator setting display register (r2Dpage[1:0] = 00)**

Bit	Name	Function	Comments
7	adc[7]	ADC readout.	Via ADC the two mixers output DC levels can be measured showing the reflectivity of the antenna or the environment. Also a DC level on the ADC pin can be measured. The latter case can be used to monitor the RF output power via an external power detector.
6	adc[6]	AD converter input is selected using msel[3:0] bits.	
5	adc[5]		
4	adc[4]	The conversion is triggered by the direct command Trigger AD conversion (87h).	
3	adc[3]		
2	adc[2]		
1	adc[1]	The result is valid 20 $\mu$ s later.	
0	adc[0]		

### 3.3.8 ADC readout/regulator setting display register (r2Dpage[1:0] = 01)

Address: 2Dh, r2Dpage[1:0] = 01

Type: R

**Table 47. ADC readout/regulator setting display register (r2Dpage[1:0] = 01)**

Bit	Name	Function	Comments
7	tcxo	Reference oscillator detection	0: OSC1 AC coupled: Crystal mode detected 1: OSC1 shorted to ground: TCXO mode detected
6	RFU	Not used	Status bits, each default set to 0
5	RFU		
4	RFU		
3	RFU		
2	vs[2]	Voltage setting used by the circuitry	000: 2.7 V
1	vs[1]		111: 3.4 V
0	vs[0]		Steps: 8 Step size: 0.1 V

### 3.3.9 Command status display register

Address: 2Eh

Type: R

Table 48. Command status display register

Bit	Name	Function	Comments
7	RFU	Not used	Default set to 0
6	autovco_done	VCO range selection finished	Signals the completion of the direct commands automatic VCO range selection (A4h) and manual VCO range selection (A5h). Triggers IRQ.
5	autosupp_done	Automatic supply selection finished	Signals the completion of the direct commands automatic power supply level setting (A2h) and manual power supply level setting (A3h). Triggers IRQ.
4	f_cal_done	Rx filter calibration finished	Signals the completion of the direct command trigger Rx filter calibration (88h). Triggers IRQ.
3	ad_conv_done	A/D conversion finished	Signals the completion of the direct command trigger AD conversion (87h). Triggers IRQ.
2	intrgAC_supp	Anti-Collision support	Interrogator anti-collision support enabled
1	AGL_on	AGL enabled	Signals the completion of the direct command AGL on (A6h) and AGL off (A7h)
0	aux_PLL_sel	Auxiliary PLL setting selected	Signals the completion of the direct commands hop to main frequency (84h) and hop to auxiliary frequency (85h)

### 3.3.10 Version register

Address: 33h

Type: R

Table 49. Version register

Bit	Name	Function	Comments
7	Version[7]		Device version number, preset to 61h
6	Version[6]		
5	Version[5]		
4	Version[4]		
3	Version[3]		
2	Version[2]		
1	Version[1]		
0	Version[0]		

## 3.4 Interrupt registers

### 3.4.1 Enable interrupt register 1

Address: 35h

Type: RW

**Table 50. Enable interrupt register 1**

Bit	Name	Default	Function	Comments
7	e_irq_TX	1	Enables corresponding interrupts of the Interrupt Register 1 (37h)	When enabled the IRQ pin is set to 1 if the corresponding IRQ occurs. The IRQ bits of registers 37h and 38h are always set
6	e_irq_Rx	1		
5	e_irq_fifo	1		
4	e_irq_err	1		
3	e_irq_header	0		
2	RFU	1		
1	e_irq_AutoACK	1		
0	e_irq_noresp	1		In case irq_noresp interrupt is disabled, the receive operation is never interrupted by the No Response Timer.

### 3.4.2 Enable interrupt register 2

Address: 36h

Type: RW

**Table 51. Enable interrupt register 2**

Bit	Name	Default	Function	Comments
7	e_irq_ana	0	Enables corresponding interrupts of Interrupt Register 2 (38 <sub>h</sub> )	When enabled the IRQ pin is set to 1 if the corresponding IRQ occurs.
6	e_irq_cmd	1		The IRQ bits of registers 37h and 38h are always set.
5	RFU	0	Not used	RFU, do not set
4	RFU	0		
3	RFU	0		
2	e_irq_err1	0	interrupts of Interrupt Register 2 (38 <sub>h</sub> )	When enabled the IRQ pin is set to 1 if the corresponding IRQ occurs.
1	e_irq_err2	0		The IRQ bits of registers 37h and 38h are always set.
0	e_irq_err3	0		

### 3.4.3 Interrupt register 1

Address: 37h

Type: R

**Table 52. Interrupt register 1**

Bit	Name	Function	Comments
7	Irq_TX	IRQ due to the end of Tx	An interrupt is generated when Tx is finished.
6	Irq_Rx	IRQ due to the end of Rx	An interrupt is generated when Rx is finished.
5	Irq_fifo	FIFO fill level	Less than 6 bytes in FIFO during Tx or more than 18 bytes in FIFO during Rx
4	Irq_err	IRQ set due to an error	Signaling a reception or transmission error
3	Irq_header / Irq_2nd_byte	Header bit / 2 <sup>nd</sup> byte	Received header bit is high / Two bytes already in the FIFO – if fifo_dir_irq2 = 1 (Register 1A <sub>h</sub> )
2	RFU	Not Used	-
1	Irq_AutoACK	Auto ACK finished	AutoACK is finished. Bit is set to 1 in the following cases: The AutoACK procedure was successfully finished. In the AutoACK procedure the ACK command was sent and the procedure was terminated due to a No Response IRQ. In the AutoACK procedure the ACK command was sent and procedure was terminated due to a reception error.
0	Irq_noresp	No response interrupt	Signals the MCU that the no response timer expired, it also interrupts receive operation.

*Note:* The content of this register is set to 0 at power up and when EN = low. It is automatically reset at the end of a read phase. A reset also removes the IRQ flag.



### 3.4.4 Interrupt register 2

Address: 38h

Type: R

**Table 53. Interrupt register 2**

Bit	Name	Function	Comments
7	Irq_ana	IRQ due to an change of the oscillator, PLL, or RF field status	To present a change of the status of osc_ok, pll_ok, rf_ok. The interrupt is triggered on both edges.
6	Irq_cmd	IRQ due to end of direct command execution	-
5	RFU	Not used	-
4	RFU		
3	RFU		
2	Irq_err1	CRC error	CRC error
1	Irq_err2	Rx data length error / protocol violation	Signals the MCU that the reception was shorter than expected (see Rx length register definition (3Ah, 3Bh) or an error caused by a disabled command or protocol violation was observed during reception.
0	Irq_err3	Preamble detect error / FIFO overflow error	Signals to MCU that there was an error during preamble detection or FIFO overflow happened during reception or transmission.

**Notes:**

1. The content of this register is set to 0 at power up and when EN = L. It is automatically reset at the end of read phase. The reset also clears the IRQ flags.
2. The IRQ pin stays high as long as at least one of the enabled IRQ bits is set in any of the two IRQ registers. Typically the MCU knows where it can expect the IRQ, and can read that register first.
3. The main error bit Irq\_err (37h) is a separate IRQ bit which is triggered by any of the error interrupt sources. The same sources are also connected to the error sub-bits Irq\_err1, Irq\_err2, Irq\_err3 (38h).
4. Optimal usage in the inventory round is having main Irq\_err enabled (e\_irq\_err = 1) and error sub-bits disabled (e\_irq\_err1 = e\_irq\_err2 = e\_irq\_err3 = 0). In this case it is sufficient to read only (37h) to clear the IRQ line to continue the inventory round. In case one is interested on the type of the error, the error sub-bits can be checked afterwards.

## 3.5 Communication registers

### 3.5.1 FIFO status register

Address: 39h

Type: R

Table 54. FIFO status register

Bit	Name	Function	Comments
7	TX_status	Tx status	1: Shows that a data transmission is in progress.
6	Rx_status	Rx status	1: Shows that a data reception is in progress.
5	Fovfl	FIFO overflow	1: More than 24 bytes were loaded to one of the FIFOs
4	Fb[4]	FIFO bytes	Number of bytes loaded in FIFO that has not been read out yet. In case an empty FIFO is read out the value 1Fh is displayed in the Fb[4:0] bits.
3	Fb[3]		
2	Fb[2]		
1	Fb[1]		
0	Fb[0]		

### 3.5.2 Rx length register 1

Address: 3Ah

Type: RW

Table 55. Rx length register 1

Bit	Name	Default	Function	Comments
7	Rx_crc_n2	0	Receiving without CRC	Temporary receiving without CRC.
6	fifo_dir_irq2	0	Direct FIFO and 2 <sup>nd</sup> byte IRQ	All bytes including CRC are transferred to FIFO, irq_header is changed to irq_2ndbyte. For PC+EPC manual reception length setting.
5	rep_irq2	0	Repeat 2 <sup>nd</sup> byte IRQ	Enables IRQ after 4 <sup>th</sup> , 6 <sup>th</sup> ... received byte. Bit can be set to 0 during reception when additional IRQs are not required. The aim is to support XPC words.

Table 55. Rx length register 1 (continued)

Bit	Name	Default	Function	Comments
4	auto_errcode_Rxl	0	Automatic tag error code Rx length preset	In case received header bit is set to 1, the Rx length is automatically changed to the tag error code length (41bits). Used to change the previously expected Rx length information when a tag transmits the error code instead of a normal response.
3	Rxl[11]	0	Rx length MSB part	-
2	Rxl[10]	0		
1	Rxl[9]	0		
0	Rxl[8]	0		

### 3.5.3 Rx length register 2

Address: 3Bh

Type: RW

Table 56. Rx length register 2

Bit	Name	Default	Function	Comments
7	Rxl[7]	0	Rx length LSB part, number of bits	In case short direct commands are used the register is automatically preset to correct expected reception length. 16 bits are expected for commands 98h, 99h, 9Ah, 9Bh, 9Ch; 32 bits are expected for the direct command 9Fh. In other cases the host system should set the expected length.
6	Rxl[6]	0		
5	Rxl[5]	0		
4	Rxl[4]	0		
3	Rxl[3]	0		
2	Rxl[2]	0		
1	Rxl[1]	0		
0	Rxl[0]	0		

### 3.5.4 Tx setting register

Address: 3Ch

Type: RW

Table 57. Tx setting register

Bit	Name	Default	Function	Comments
7	RFU	0	Not used	RFU, do not set
6	RFU	0		
5	RFU	0		
4	RFU	0		

**Table 57. Tx setting register (continued)**

Bit	Name	Default	Function	Comments
3	TXCRC_5	0	Tx CRC type	0: CRC-16 1: CRC-5
2	Force_TRcal	0	TRcal period in normal transmission	Normally TRcal is automatically transmitted when the direct command Query (98h), according to EPC Gen2 and ISO18000-6C, is issued. In case Force_TRcal = 1 the TRcal period is transmitted also in normal data transmission (direct commands 90h, 91h)
1	S1	0	Session bits	Used for Gen 2 direct commands Query (98h).
0	S0	0		

### 3.5.5 Tx length register 1

Address: 3Dh

Type: RW

**Table 58. Tx length register 1**

Bit	Name	Default	Function	Comments
7	TXI[11]	0	Tx length high nibble	High and mid nibbles of complete bytes being transmitted through the FIFO
6	TXI[10]	0		
5	TXI[9]	0		
4	TXI[8]	0		
3	TXI[7]	0	Tx length mid nibble	
2	TXI[6]	0		
1	TXI[5]	0		
0	TXI[4]	0		

### 3.5.6 Tx length register 2

Address: 3Eh

Type: RW

**Table 59. Tx length register 2**

Bit	Name	Default	Function	Comments
7	TXI[3]	0	Tx length low nibble	Low nibbles of complete bytes being transmitted through the FIFO
6	TXI[2]	0		
5	TXI[1]	0		
4	TXI[0]	0		

**Table 59. Tx length register 2 (continued)**

Bit	Name	Default	Function	Comments
3	Bb[2]	0	Number of bits in broken byte	Number of bits in the last (broken) byte to be transmitted
2	Bb[1]	0		
1	Bb[0]	0		
0	RFU	0	Not used	RFU, do not set

### 3.5.7 FIFO I/O register

Address: 3Fh

Type: RW

**Table 60. FIFO I/O register**

Bit	Name	Function	Comments
-	FIFO	2 x 24 bytes FIFO register filled and read in cyclic way	-

## 4 Pinouts and pin description

The ST25RU3993 pin assignments are described in [Figure 14](#).

**Figure 14. ST25RU3993 pinout**

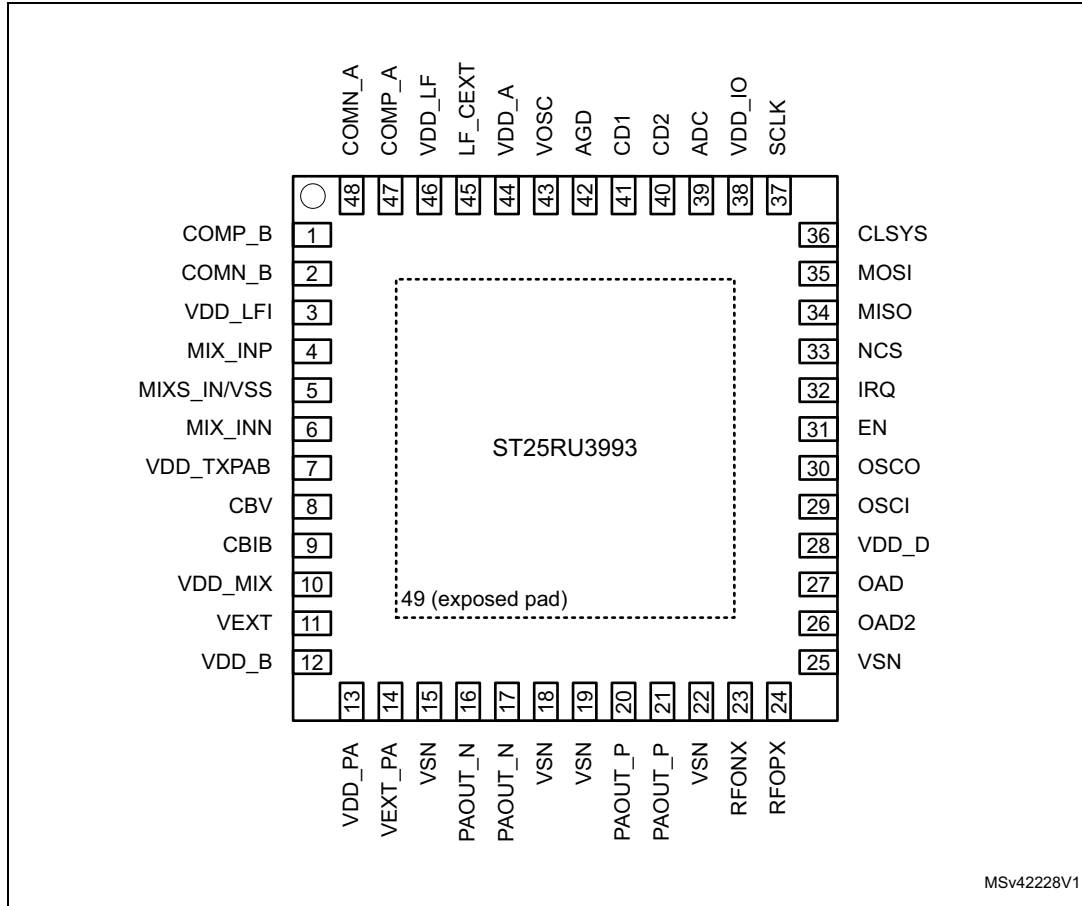

MSv42228V1

1. The above figure shows the package top view

**Table 61. ST25RU3993 pin definitions**

Pin number	Pin name	Pin type	Description
1	COMP_B	Analog I/O	Internal node, connect de-coupling capacitor to V <sub>DD_LFI</sub>
2	COMN_B	Analog I/O	Internal node, connect de-coupling capacitor to V <sub>DD_LFI</sub>
3	V <sub>DD_LFI</sub>	Supply pad	Positive supply for LF input stage, connect to V <sub>DD_MIX</sub>
4	MIX_INP	Analog input	Positive differential mixer input
5	MIXS_IN/V <sub>SS</sub>	Analog input	Single ended mixer input
6	MIX_INN	Analog input	Negative differential mixer input

Table 61. ST25RU3993 pin definitions

Pin number	Pin name	Pin type	Description
7	V <sub>DD_TXPAB</sub>	Supply pad	Bias positive supply. Connect to V <sub>DD_MIX</sub>
8	CBV	Analog I/O	Internal node, connect de-coupling capacitor to V <sub>DD_MIX</sub>
9	CBIB	Analog I/O	Internal node, connect de-coupling capacitor to ground
10	V <sub>DD_MIX</sub>	Analog I/O	Mixer positive supply, internally regulated
11	V <sub>EXT</sub>	Supply pad	Main positive supply input, input to regulators
12	V <sub>DD_B</sub>	Analog I/O	Buffer positive supply, internally regulated
13	V <sub>DD_PA</sub>	Analog I/O	PA positive supply, internally regulated
14	V <sub>EXT_PA</sub>	Supply pad	PA positive supply regulator input
15	VSN	Supply pad	Negative supply
16	PAOUT_N	Analog output	Negative PA RF output
17	PAOUT_N	Analog output	Negative PA RF output
18	VSN	Supply pad	Negative supply
19	VSN	Supply pad	Negative supply
20	PAOUT_P	Analog output	Positive PA RF output
21	PAOUT_P	Analog output	Positive PA RF output
22	VSN	Supply pad	Negative supply
23	RFOX	Analog output	low-power linear negative RF output (~0dBm)
24	RFOX	Analog output	low-power linear positive RF output (~0dBm)
25	VSN	Supply pad	Negative supply
26	OAD2	Analog I/O	Analog or digital received signal output
27	OAD	Analog I/O	Analog or digital received signal output
28	V <sub>DD_D</sub>	Analog I/O	Positive supply for logic, internally regulated
29	OSCI	Analog input	Crystal oscillator input or short to ground if external TCXO is used
30	OSCO	Analog I/O	Crystal oscillator output or external 20MHz clock input
31	EN	Digital input	Enable input
32	IRQ	Digital output	Interrupt request output

Table 61. ST25RU3993 pin definitions

Pin number	Pin name	Pin type	Description
33	NCS	Digital input	SPI enable (active low)
34	MISO	Digital output / tri-state	SPI data output
35	MOSI	Digital input	Serial peripheral interface data input
36	CLSYS	Digital output	Clock output for MCU
37	SCLK	Digital input	SPI clock
38	V <sub>DD_IO</sub>	Supply pad	Positive supply for peripheral communication, connect to host positive supply.
39	ADC	Analog input	ADC input for external power detector support
40	CD2	Analog I/O	Internal node de-coupling capacitor
41	CD1	Analog I/O	Internal node de-coupling capacitor
42	AGD	Analog I/O	Analog reference voltage
43	VOSC	Analog I/O	Internal node de-coupling capacitor
44	V <sub>DD_A</sub>	Analog I/O	Analog part positive supply, internally regulated
45	LF_CEXT	Analog output	PLL loop filter
46	V <sub>DD_LF</sub>	Analog I/O	Positive supply for LF processing, internally regulated
47	COMP_A	Analog I/O	Internal node, connect de-coupling capacitor to V <sub>DD_LFI</sub>
48	COMN_A	Analog I/O	Internal node, connect de-coupling capacitor to V <sub>DD_LFI</sub>
49	Exposed Pad	Supply pad	Exposed pad of the package



## 5 Electrical characteristics

### 5.1 Absolute maximum ratings

Stresses beyond those listed under absolute maximum ratings may cause permanent damage to the device. These are stress ratings only. Functional operation of the device at these or any other conditions beyond those indicated under electrical characteristics is not implied. Exposure to absolute maximum rating conditions for extended periods may affect device reliability.

**Table 62. Electrical parameters**

Symbol	Parameter	Min	Max	Unit	Comment
$V_{DD\_IO}$	Supply voltage $V_{DD\_IO}$	-0.3	6.0	V	-
$V_{EXT}$	Supply voltage $V_{EXT}$	-0.3	4	V	-
$V_{EXT\_PA}$	Supply voltage $V_{EXT\_PA}$	-0.3	5	V	-
$V_{INH}$	Input pin voltage host interface	-0.3	$V_{DD\_IO} + 0.5$	V	Valid for inputs EN, IRQ, MOSI, SCLK, NCS
$V_{INO}$	Input pin voltage, other pins	-0.3	$V_{EXT} + 0.5$	V	-
$I_{scr}$	Input current (latch-up immunity)	-100	100	mA	JEDEC 78, AGD excluded from latch-up immunity test when EN is high. AGD is a reference voltage pin and must be kept at the reference voltage.

**Table 63. Electrostatic discharge**

Symbol	Parameter	Min	Max	Unit	Comment
$ESD_{HBM}$	Electrostatic discharge for RF pins 4, 5, 6, 16, 17, 20, 21, 23, 24	±1		kV	JESD22-A114E
	Electrostatic discharge for other pins	±2		kV	

**Table 64. Continuous power dissipation**

Symbol	Parameter	Min	Max	Unit	Comment
$P_T$	Total power dissipation (all supplies and outputs)	-	1.6	W	-

**Table 65. Temperature ranges and storage conditions**

Symbol	Parameter	Min	Max	Unit	Comment
T <sub>J</sub>	Maximum operating virtual junction temperature	-	120	°C	-
T <sub>strg</sub>	Storage temperature	-55	125	°C	-
T <sub>body</sub>	Package body temperature	-	260	°C	IPC/JEDEC J-STD-020. The reflow peak soldering temperature (body temperature) is specified according IPC/JEDEC J-STD-020 "Moisture/Reflow sensitivity classification for non-hermetic solid state surface mount devices. The lead finish for Pb-free leaded packages is "Matte Tin" (100% Sn).
RH <sub>NC</sub>	Relative humidity (non condensing)	5	85	%	-
MSL	Moisture sensitivity level	3		-	Represents a max. floor life time of 168h

## 5.2 Operating conditions

All limits are guaranteed. The parameters with min and max values are guaranteed with production tests or SQC (Statistical Quality Control) methods.

VEXT = 3.3 V, VEXT\_PA = 3.3 V, VDD\_IO = 3.3 V, T<sub>AMB</sub> = 25 °C unless otherwise noted.

**Table 66. Operating conditions**

Symbol	Parameter	Conditions	Min	Typ	Max	Unit
I <sub>EXT</sub>	Supply current without V <sub>DD_PA</sub> current	V <sub>EXT</sub> consumption	65 <sup>(1)</sup>	75	-	mA
I <sub>EXT_PA</sub>	Supply current for internal PA	V <sub>DD_PA</sub> = 3 V pa_bias[1:0] = 00b TX_lev[4:0] = 00000b eTX[3:2] = 10b	-	120	-	mA
		V <sub>DD_PA</sub> = 3 V pa_bias[1:0] = 01b TX_lev[4:0] = 00000b eTX[3:2] = 10b	-	180	-	
I <sub>STBY</sub>	Supply current in standby mode	-	-	3	-	mA

Table 66. Operating conditions (continued)

Symbol	Parameter	Conditions	Min	Typ	Max	Unit
$I_{PD}$	Supply current in power-down mode	All system disabled including supply voltage regulators	-	1	10	$\mu A$
$V_{AGD}$	AGD voltage	-	1.45	1.55	1.65	V
$V_{POR}$	Power-on reset voltage (POR)	-	1	1.8	2.0	V
$V_{RD}$	Regulator drop	(2)	-	300	-	mV
$V_{DD\_PA}$	Regulated supply for internal PA	-	-	3	-	V
$P_{PSSR}$	Rejection of external supply noise on the supply regulator	(3)	-	26	-	dB
$P_{RFAUX}$	Auxiliary RF output power	$V_{DD\_B} = 3 V$	-	0	-	dBm
$P_{PAOUT}$	Internal PA output power	$V_{DD\_PA} = 3 V$ $pa\_bias[1:0] = 00b$ $TX\_lev[4:0] = 00000b$ $eTX[3:2] = 10b$	-	17	-	dBm
		$V_{DD\_PA} = 3 V$ $pa\_bias[1:0] = 01b$ $TX\_lev[4:0] = 00000b$ $eTX[3:2] = 10b$	-	20	-	

- Using  $ic\_bia\_m[1:0]$  option bits, the consumption can be decreased up to 9%. The drawback of decreased power consumption can be higher noise, lower output power, and declining sensitivity.
- After execution of direct command: automatic power supply level setting (A2h).
- The difference between the external supply and the regulated voltage is higher than 300mV.

Table 67. Differential mixer

Symbol	Parameter	Conditions	Min	Typ	Max	Unit
$R_{RFIN\_DIFF}$	Diff. mixer input impedance	-	-	100	-	$\Omega$
$V_{SENS\_NOM\_DIFF}$	Nominal diff. mixer input sensitivity	Nominal diff. mixer setting, PER=0.1%	-	-67	-	dBm
$V_{SENS\_GAIN\_DIFF}$	Increased diff. mixer input sensitivity	Increased diff. mixer gain, PER=0.1%	-	-77	-	dBm
$V_{SENS\_LBT\_DIFF}$	Diff. mixer LBT sensitivity	Maximum diff. mixer LBT sensitivity	-	-90	-	dBm
$IP3_{DIFF}$	Diff. mixer third order intercept point	Nominal diff. mixer setting $V_{EXT} = 3 V$	-	20	-	dBm

**Table 67. Differential mixer (continued)**

Symbol	Parameter	Conditions	Min	Typ	Max	Unit
1dBcp_DIFF	Diff. mixer input 1dB compression point	Nominal diff. mixer setting VEXT = 3 V	-	9	-	dBm
T_REC_DIFF	Recovery time after modulation	Maximum LF selected	-	18	-	µs

**Table 68. Single-ended mixer**

Symbol	Parameter	Conditions	Min	Typ	Max	Unit
R_RFIN_SE	Single ended mixer input impedance	-	-	50	-	Ω
V_SENS_NOM_SE	Nominal SE input sensitivity	Nominal SE mixer setting, PER=0.1%	-	-67	-	dBm
V_SENS_GAIN_SE	Increased SE input sensitivity	Increased SE mixer gain, PER=0.1%	-	-77	-	dBm
V_SENS_LBT_SE	SE mixer LBT sensitivity	Maximum SE mixer LBT sensitivity	-	-90	-	dBm
IP3_SE	SE mixer third order intercept point	Nominal SE mixer setting <sup>(1)</sup> VEXT = 3 V	-	17	-	dBm
1dBcp_SE	SE mixer input 1dB compression point	Nominal SE mixer setting <sup>(1)</sup> VEXT = 3 V	-	7	-	dBm
T_REC_SE	Recovery time after modulation	Maximum LF selected	-	18	-	µs

1. Register settings for nominal mixer settings: 0A:01h, 0D:84h, 22:13h.

**Table 69. CMOS Input (valid for all CMOS inputs)<sup>(1)</sup>**

Symbol	Parameter	Conditions	Min	Typ	Max	Unit
V_IH	High level input voltage	(2)	0.8 * V <sub>DD_IO</sub>	-	-	V
V_IL	Low level input voltage	(3)	-	-	0.2 * V <sub>DD_IO</sub>	V
I_LEAK	Input leakage current	-	-	-	1	µA

1. On all outputs, it is recommended to use loads with the smallest required current driving capability in order to prevent current/spikes.
2. At supply voltage ≤1.8 V, the minimum V<sub>IH</sub> is defined as 0.9\*V<sub>DD\_IO</sub>.
3. At supply voltage ≤1.8 V, the maximum V<sub>IL</sub> is defined as 0.1\*V<sub>DD\_IO</sub>.

Table 70. CMOS output (valid for all CMOS outputs)

Symbol	Parameter	Conditions	Min	Typ	Max	Unit
f <sub>SCLK</sub>	SCLK frequency	hs_output = 1 <sup>(1)</sup> , V <sub>DD_IO</sub> ≥ 3 V, C <sub>LOAD</sub> = 50 pF	-	-	5	MHz
		hs_output = 1, V <sub>DD_IO</sub> ≥ 1.65 V, C <sub>LOAD</sub> = 50 pF	-	-	3	MHz
		hs_output = 0, V <sub>DD_IO</sub> ≥ 3 V, C <sub>LOAD</sub> = 50 pF	-	-	2	MHz
R <sub>NMOS</sub>	Output NMOS resistance on digital pins	hs_output = 1	-	120	-	Ω
R <sub>PMOS</sub>	Output PMOS resistance on digital pins	hs_output = 1, V <sub>DD_IO</sub> > 3 V	-	150	-	Ω
		hs_output = 1, V <sub>DD_IO</sub> > 1.65 V	-	300	-	Ω

1. Option bit 7 of [Miscellaneous register 1](#).

### 5.3 Typical operating characteristics

All defined tolerances for external components in this specification need to be assured over the whole operation condition range and also over lifetime.

Table 71. Typical operating characteristics

Symbol	Parameter	Min	Max	Unit	Comment
V <sub>DD_IO</sub>	Positive supply voltage V <sub>DD_IO</sub>	1.65	5.5	V	-
V <sub>EXT</sub>	Positive supply voltage V <sub>EXT</sub>	2.7	3.6	V	For optimal power supply rejection and performance a supply voltage of at least 3.3 V is required. A supply voltage above 3.0 V allows operation with reduced power supply rejection. Operation down to 2.7 V is possible with reduced performance.
V <sub>EXT_PA</sub>	Positive supply voltage V <sub>EXTRF</sub>	2.7	4.3	V	
V <sub>SS</sub>	Negative supply voltage	0	0	V	Valid for all V <sub>SS</sub> and V <sub>SN</sub> pins
T <sub>AMB</sub>	Ambient temperature	-40	85	°C	-

## 6 Package information

In order to meet environmental requirements, ST offers these devices in different grades of ECOPACK<sup>®</sup> packages, depending on their level of environmental compliance. ECOPACK<sup>®</sup> specifications, grade definitions and product status are available at [www.st.com](http://www.st.com).

ECOPACK<sup>®</sup> is an ST trademark.

### 6.1 QFN48 package information

The ST25RU3993 is available in a 48-pin QFN (7 x 7 mm) package (see [Figure 15](#)).

The dimensions are detailed in millimeters.

Figure 15. QFN48, 7x7 mm, 0.5 mm pitch, package outline

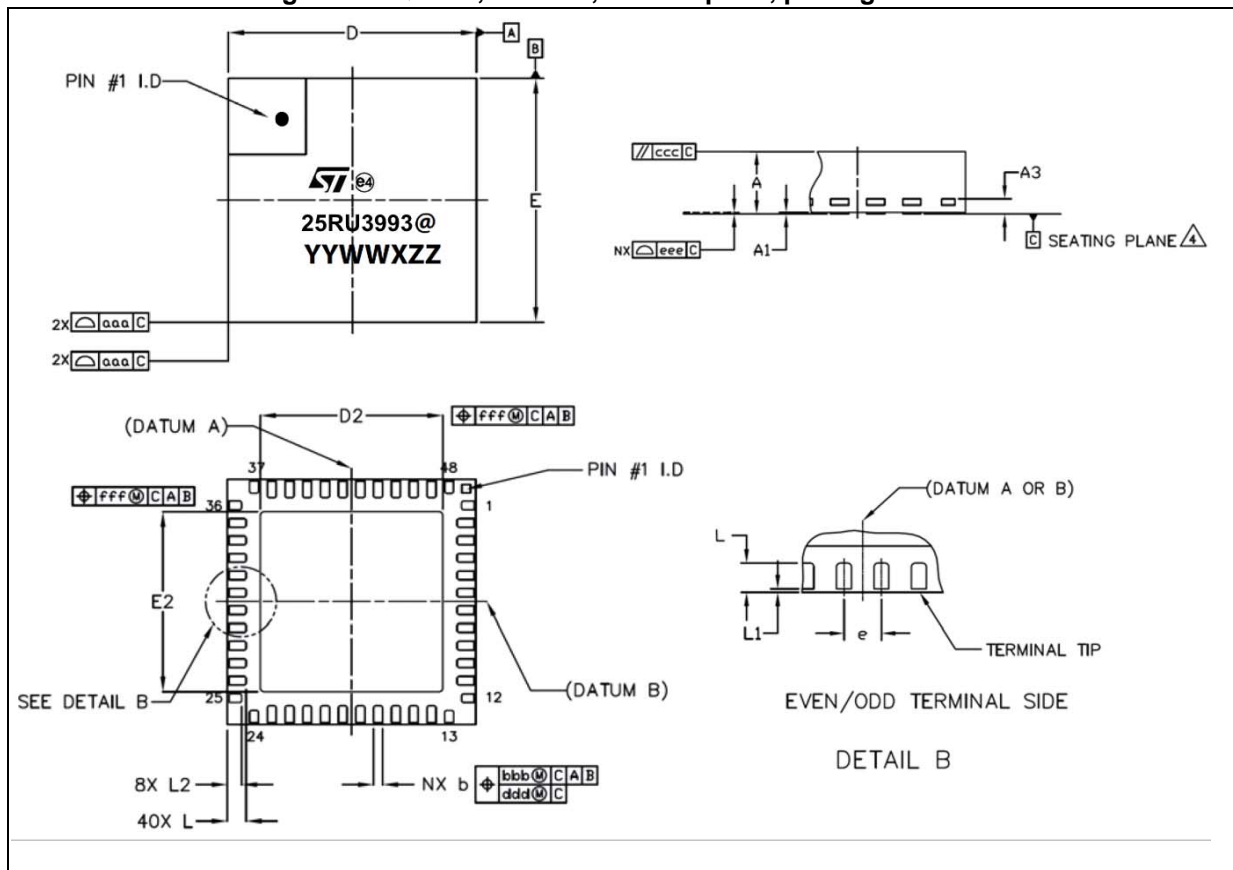

1. All dimensions are in millimeters. Angles are in degrees.
2. Dimension b applies to metallized terminal and is measured between 0.25mm and 0.30mm from terminal tip. Dimension L1 represents terminal full back from package edge up to 0.15mm is acceptable.
3. Co-planarity applies to the exposed heat slug as well as the terminal.
4. Radius on terminal is optional.
5. This drawing is subject to change without notice.
6. N = 48, it indicate the pins number.

Table 72. QFN48, 7x7 mm, 0.5 mm pitch, package mechanical data

Symbol	millimeters			inches <sup>(1)</sup>		
	Min	Typ	Max	Min	Typ	Max
A	0.8	0.9	1.0	0.0315	0.0354	0.0394
A1	0	0.02	0.05	0	0.0008	0.0020
A3	-	0.2 REF	-	-	0.0079 REF	-
b	0.18	0.25	0.30	0.0071	0.0098	0.0118
D	-	7 BSC	-	-	0.2756 BSC	-
E	-	7 BSC	-	-	0.2756 BSC	-
e	-	0.5	-	-	0.0197	-
D2	5.04	5.14	5.24	0.1984	0.2024	0.2063
E2	5.04	5.14	5.24	0.1984	0.2024	0.2063
L	0.48	0.53	0.58	0.0189	0.0209	0.0228
L1	0	-	0.15	0	-	0.0059
L2	0.35	0.4	0.45	0.0138	0.0157	0.0177
aaa	-	0.15	-	-	0.0059	-
bbb	-	0.10	-	-	0.0039	-
ccc	-	0.10	-	-	0.0039	-
ddd	-	0.05	-	-	0.0020	-
eee	-	0.08	-	-	0.0031	-
fff	-	0.10	-	-	0.0039	-

1. Values in inches are converted from mm and rounded to 4 decimal digits.

Table 73. Package codification

@	YY	WW	X	ZZ
Sublot identifier	Year	Working week assembly / packaging	Plant identifier	Free choice / traceability code

# 7 Part numbering

**Table 74. Ordering information scheme**

Example:	ST25RU	39	93 -	B	QF	T
<b>Device type</b>	ST25 = RFID tags and readers					
<b>Product type</b>	RU = UHF Reader					
<b>Frequency range</b>	39 = RF products					
<b>Product feature</b>	93 = High Performance reader supporting Gen2					
<b>Temperature range</b>	B = -40 °C to 85 °C					
<b>Package/Packaging</b>	QF = 48-pin QFN (7 x 7 mm)					
<b>Tape and Reel</b>	T = 500 pcs/reel					

*Note: Parts marked as “ES”, “E” or accompanied by an Engineering Sample notification letter, are not yet qualified and therefore not yet ready to be used in production and any consequences deriving from such usage will not be at ST charge. In no event, ST will be liable for any customer usage of these engineering samples in production. ST Quality has to be contacted prior to any decision to use these Engineering samples to run qualification activity.*



## 8 Revision history

**Table 75. Document revision history**

Date	Revision	Changes
09-Nov-2016	1	Initial release.
24-Nov-2016	2	Updated <a href="#">Table 66: Operating conditions</a>
07-Dec-2016	3	Updated <a href="#">Table 67: Differential mixer</a> and <a href="#">Table 68: Single-ended mixer</a>
22-Dec-2016	4	Updated <a href="#">Table 74: Ordering information scheme</a>
20-Mar-2017	5	Updated <a href="#">Table 74: Ordering information scheme</a>
22-Mar-2018	6	Added <a href="#">Figure 8: Sending direct commands</a> , <a href="#">Table 73: Package codification</a> Updated <a href="#">Table 3: SPI operation modes</a> , <a href="#">Table 52: Interrupt register 1</a> , <a href="#">Figure 15: QFN48, 7x7 mm, 0.5 mm pitch, package outline</a>
07-Jan-2019	7	Updated <a href="#">Description</a> , document title and added Rain <sup>®</sup> RFID logo.
27-May-2019	8	Updated <a href="#">Table 66: Operating conditions</a>
16-Oct-2019	9	Updated <a href="#">Features</a> .

**IMPORTANT NOTICE – PLEASE READ CAREFULLY**

STMicroelectronics NV and its subsidiaries (“ST”) reserve the right to make changes, corrections, enhancements, modifications, and improvements to ST products and/or to this document at any time without notice. Purchasers should obtain the latest relevant information on ST products before placing orders. ST products are sold pursuant to ST’s terms and conditions of sale in place at the time of order acknowledgement.

Purchasers are solely responsible for the choice, selection, and use of ST products and ST assumes no liability for application assistance or the design of Purchasers’ products.

No license, express or implied, to any intellectual property right is granted by ST herein.

Resale of ST products with provisions different from the information set forth herein shall void any warranty granted by ST for such product.

ST and the ST logo are trademarks of ST. For additional information about ST trademarks, please refer to [www.st.com/trademarks](http://www.st.com/trademarks). All other product or service names are the property of their respective owners.

Information in this document supersedes and replaces information previously supplied in any prior versions of this document.

© 2019 STMicroelectronics – All rights reserved

# Mouser Electronics

Authorized Distributor

Click to View Pricing, Inventory, Delivery & Lifecycle Information:

[STMicroelectronics:](#)

[ST25RU3993-BQFT](#)