

## Overview

CH32V series is an industrial-grade general-purpose microcontroller based on QingKe RISC-V core, including CH32V305 connected MCU, CH32V307 interconnected MCU, CH32V208 wireless MCU, etc. The CH32V30x series is based on QingKe V4F microprocessor design, supports single-precision floating-point instruction and fast interrupt response, supports 144MHz main frequency zero-wait operation, provides 8 groups of U(S)ART, 4 groups of motor PWM advanced timers, SDIO, DVP, 4 groups of analog OPA, dual ADC units, dual DAC units, built-in USB2.0 high-speed PHY transceivers (480Mbps), Gigabit Ethernet MAC and 10M PHY transceivers.

## Features

- **Core:**
  - QingKe 32-bit RISC-V4F core with multiple instruction set combinations
  - Fast programmable interrupt controller + hardware interrupt stack
  - Branch prediction, conflict handling mechanism
  - Single cycle multiplication, hardware division, hardware FPU
  - System main frequency 144MHz, zero wait
- **Memory:**
  - Available with up to 128KB volatile data storage area SRAM
  - Available with 480KB program memory CodeFlash (zero-wait application area + non-zero-wait data area)
  - 28KB SystemFLASH
  - 128B non-volatile system configuration memory
  - 128B user-defined memory
- **Power management and low-power consumption:**
  - System power supply  $V_{DD}$ : 3.3V
  - Independent power supply for GPIO unit  $V_{IO}$ : 3.3V
  - Low-power mode: Sleep, Stop, Standby
  - $V_{BAT}$  independently powers RTC and backup register
- **Clock & Reset**
  - Built-in factory-trimmed 8MHz RC oscillator
  - Built-in about 40 KHz RC oscillator
  - Built-in PLL, optional CPU clock up to 144MHz
  - High-speed external 3~25MHz oscillator
  - Low-speed external 32.768 KHz oscillator
- Power on/down reset, programmable voltage detector
- **Real-time clock (RTC): 32-bit independent RTC timer**
- **2 groups of 18-channel general-purpose DMA controllers**
  - 18 channels, support ring buffer
- Support TIMx/ADC/DAC/USART/I2C/SPI/I2S/SDIO
- **4 groups of OPAs and comparators: connected with ADC and TIMx**
- **2 groups of 12-bit DAC**
- **2 groups of 12-bit ADC**
  - Analog input range:  $V_{SSA} \sim V_{DDA}$
  - 16 external signals + 2 internal signals
  - On-chip temperature sensor
  - Dual ADC conversion mode
- **16-channels Touch-Key detection timers**
- **Multiple timers**
  - 4×16-bit advanced timers, support dead-zone control and emergency braking, provide PWM complementary output for motor control
  - 4×16-bit general-purpose timers, provide input capture/output comparison/PWM/pulse counting/incremental encoder input
  - 2 basic timers
  - 2 watchdog timers (independent watchdog and window watchdog)
  - SysTick: 64-bit counter
- **Communication interfaces:**
  - 8 USART interfaces (including 5 UARTs)

- 2 I2C interfaces (support SMBus/PMBus)
- 3 SPI interfaces (SPI2, SPI3 for I2S2, I2S3)
- USB2.0 full-speed host/device interface, built-in PHY
- USB2.0 full-speed OTG interface
- USB2.0 high-speed host/device interface, built-in PHY
- 2 CAN interfaces (2.0B active)
- SDIO host interface (MMC, SD/SDIO, CE-ATA)
- FSMC memory interface

- Digital video port (DVP)
- Gigabit Ethernet controller MAC, 10M PHY transceiver
- **Fast GPIO port**
- 80 I/O ports, mapping 16 external interrupts
- **Security features: CRC unit, 96-bit unique ID**
- **Debug mode: 2-wire serial debug interface (SDI)**
- **Package: LQFP, QFN or TSSOP**

## Chapter 1 Series Product Description

CH32V series products are industrial-grade general-purpose enhanced MCU based on 32-bit RISC-V instruction set architecture, which are divided into general, connected, wireless and other categories according to functional resources. They extend each other in terms of package category, peripheral resources and quantity, pin number and device characteristics, but maintain mutual compatibility in software, function and hardware pin configuration. It provides freedom and convenience for users to carry out product iteration and rapid application in product development.

For the features of this series of products, please refer to the datasheet.

For the peripheral function description, usage and register configuration, please refer to "CH32FV2\_V3RM".

The datasheets and reference manuals can be downloaded on the official website of WCH: <https://www.wch-ic.com/>

Information about the RISC-V instruction set architecture can be downloaded from: <https://riscv.org/>

This manual is for CH32V303, CH32V305, CH32V307 series datasheet. Please refer to *CH32V203DS0* for V203 series and *CH32V208DS0* for V208 series.

Table 1-1 Series overview

Small-and-medium capacity general-purpose device (V203)		High-capacity general-purpose device (V303)		Connectivity device (V305)	Interconnectivity device (V307)	Wireless device (V208)
QingKe V4B		QingKe V4F				QingKe V4C
32K Flash	64K Flash	128K Flash	256K Flash	128K Flash	256K Flash	128K Flash
10K SRAM	20K SRAM	32K SRAM	64K SRAM	32K SRAM	64K SRAM	64K SRAM
2*ADC(TKey)	2*ADC(TKey)	2*ADC(TKey)	2*ADC(TKey)	2*ADC(TKey)	2*ADC(TKey)	ADC(TKey)
ADTM	ADTM	2*DAC	2*DAC	2*DAC	4*ADTM	ADTM
3*GPTM	3*GPTM	ADTM	4*ADTM	4*ADTM	4*GPTM	3*GPTM
2*USART	4*USART	3*GPTM	4*GPTM	4*GPTM	2*BCTM	GPTM(32)
SPI	2*SPI	3*USART	2*BCTM	2*BCTM	8*USART/UART	4*USART/UART
I2C	2*I2C	2*SPI	8*USART/UART	5*USART/UART	3*SPI(2*I <sup>2</sup> S)	2*SPI
USBBD	USBBD	2*I2C	3*SPI(2*I <sup>2</sup> S)	3*SPI(2*I <sup>2</sup> S)	2*I2C	2*I2C
USBFS	USBFS	USBFS	2*I2C	2*I2C	OTG_FS	USBBD
CAN	CAN	CAN	USBFS	2*I2C	USBHS(+PHY)	USBFS
RTC	RTC	RTC	CAN	OTG_FS	2*CAN	CAN
2*WDG	2*WDG	2*WDG	RTC	USBHS(+PHY)	RTC	RTC
2*OPA	2*OPA	4*OPA	2*WDG	2*CAN	2*CAN	2*WDG
		RNG	4*OPA	RTC	4*OPA	2*WDG
		SDIO	RNG	2*WDG	RNG	2*OPA
		FSMC	SDIO	4*OPA	4*OPA	ETH-
			FSMC	RNG	SDIO	10M(+PHY)
				SDIO	RNG	BLE5.3
					FSMC	
					DVP	
					ETH-1000MAC	
					10M-PHY	

Note: The number of peripherals or functions of some products in the same category may be limited by the package, please confirm the product package when selecting.

Abbreviations:

ADTM: Advanced-control timer

GPTM: General-purpose timer

GPTM (32) :32-bit General-purpose timer

BCTM: Basic timer

TKey: Touch Key

OPA: Operational amplifier/comparator

RNG: Random number generator

USB D: Universal serial bus full-speed device

USBFS: Universal serial bus full-speed host/device

USBHS: Universal serial bus high-speed host/device

Table 1-2 Overview of MCU Cores

Core	Feature	Instruction Set	Hardware stack level	Interrupt nesting level	Fast interrupt channels	Integer division period	Vector table mode	Extended instruction	Memory protection
QingKe V4B		IMAC	2	2	4	9	Address or instruction	Support	No
QingKe V4C		IMAC	2	2	4	5	Address or instruction	Support	Standard
QingKe V4F		IMAFC	3	8	4	5	Address or instruction	Support	Standard

Note: For information about the core, please refer to "QingKeV4\_Processor\_Manual".

## Chapter 2 Specification

CH32V30x series is a 32-bit RISC-V core MCU based on QingKe V4F microprocessor. It works at 144MHz frequency and has built-in high-speed memory. Multiple buses work synchronously in the system structure, providing rich peripheral functions and enhanced Imax O ports. This series includes 2 12-bit ADC modules, 2 12-bit DAC modules, multiple timers, multi-channel touch key capacitance detection (TKey) and other functions, as well as standard and dedicated communication interfaces: I2C, I2S, SPI, USART, SDIO, CAN controller, USB2.0 full-speed host / device controller, USB2.0 high-speed host / device controller (built-in 480Mbps transceiver), digital image interface, Gigabit Ethernet controller, etc.

The rated working voltage of the product is 3.3V, and the working temperature range is -40°C~85°C in industrial grade. It supports several power-saving operating modes to meet the product's low-power application requirements. Various models in the series are different in terms of resource allocation, number of peripherals, peripheral functions, etc., and can be selected as needed.

### 2.1 Model Comparison

Table 2-1 High-density general-purpose/connectivity/interconnectivity products resource allocation

Differences		Part No.	CH32V303				CH32V305			CH32V307				
			CB	RB	RC	VC	FB	GB	RB	RC	WC	VC		
Pin count			48	64	64	100	20	28	64	64	68	100		
Flash (bytes) <sup>(1)</sup>			128K	128K	256K <sup>(2)</sup>	256K <sup>(2)</sup>	128K	128K	128K	256K <sup>(2)</sup>	256K <sup>(2)</sup>	256K <sup>(2)</sup>		
SRAM (bytes)			32K	32K	64K <sup>(2)</sup>	64K <sup>(2)</sup>	32K	32K	32K	64K <sup>(2)</sup>	64K <sup>(2)</sup>	64K <sup>(2)</sup>		
GPIO port count			37	51	51	80	17	24	51	51	54	80		
GPIO power supply			Shared			Independent supply V <sub>IO</sub>			Shared			Independent supply V <sub>IO</sub>		
Timer	Advanced-control (16-bit)		1	1	4	4	4 <sup>(3)</sup>	4	4	4	4	4		
	General- purpose (16-bit)		3	3	4	4	4 <sup>(3)</sup>	4	4	4	4	4		
	Basic (16-bit)		-		2	2	2	2	2	2	2	2		
	Watchdog		2 ( WWDG + IWDG )											
	SysTick (64-bit)		Supported											
RTC			Supported											
ADC/TKey	Unit		2	2	2	2	2	2	2	2	2	2		
	Channel		10	16	16	16	1	6	16	16	16	16		
DAC (unit)			2	2	2	2	DAC2	DAC2	2	2	2	2		
OPA/CMP			4	4	4	4	-	OPA3	4	4	4	4		
RNG			-	-	1	1	1	1	1	1	1	1		
Communication interfaces	USART/UART		3	3	8	8	USART1 /3	5	5	8	8	8		
	SPI		2	2	3	3	SPI2	3	3	3	3	3		
	I2S		-	-	2	2	I2S2	2	2	2	2	2		
	I2C		2	2	2	2	2	2	2	2	2	2		

Differences		Part No.	CH32V303				CH32V305			CH32V307		
		CB	RB	RC	VC	FB	GB	RB	RC	WC	VC	
CAN		1	1	1	1	CAN2	2	2	2	2	2	
SDIO		-	-	1	1	-	1	1	1	1	1	
USB(FS)	USBH D	1	1	1	1	-	-	1	1	1	1	
USBHS (with PHY)		-				1	1	1	1	1	1	
Ethernet		-							1G MAC+10M PHY			
DVP		-									1	
FSMC		-			1	-				1		
CPU main frequency		Max: 144MHz										
Operating temperature		Industrial-grade: -40°C~85°C										
Package form		LQFP48	LQFP64M	LQFP100	TSSOP20	QFN28	LQFP64 M	LQFP64 M	QFN68	LQFP100		

Note: 1. Flash bytes represent zero-wait run area R0WAIT. For the V303/V305/V307 series, non-zero-wait area is (480K-R0WAIT).

2. The products with 256K FLASH+64K SRAM support user select word to be configured as one of several combinations of (192K FLASH+128K SRAM), (224K FLASH+96K SRAM), (256K FLASH+64K SRAM), (288K FLASH+32K SRAM).

3. In actual application, please confirm the pinouts of the selected device first before using the functions involving pin signals such as PWM and capture in the timer. Devices in some packages may not have the corresponding function pins and such functions cannot be used.

## 2.2 System Architecture

The microcontroller is based on the RISC-V instruction set architecture (ISA) in which the core, arbitration unit, DMA module, SRAM storage and other parts are interacted through multiple sets of buses. A general-purpose DMA controller is integrated in the chip to reduce the burden on the CPU and improve access efficiency. The application of a multi-level clock management mechanism reduces the operating power consumption of peripherals. At the same time, it has a data protection mechanism and measures such as automatic clock switching protection to increase system stability. The following figure is a block diagram of the overall internal structure of the series of products.

Figure 2-1 System block diagram

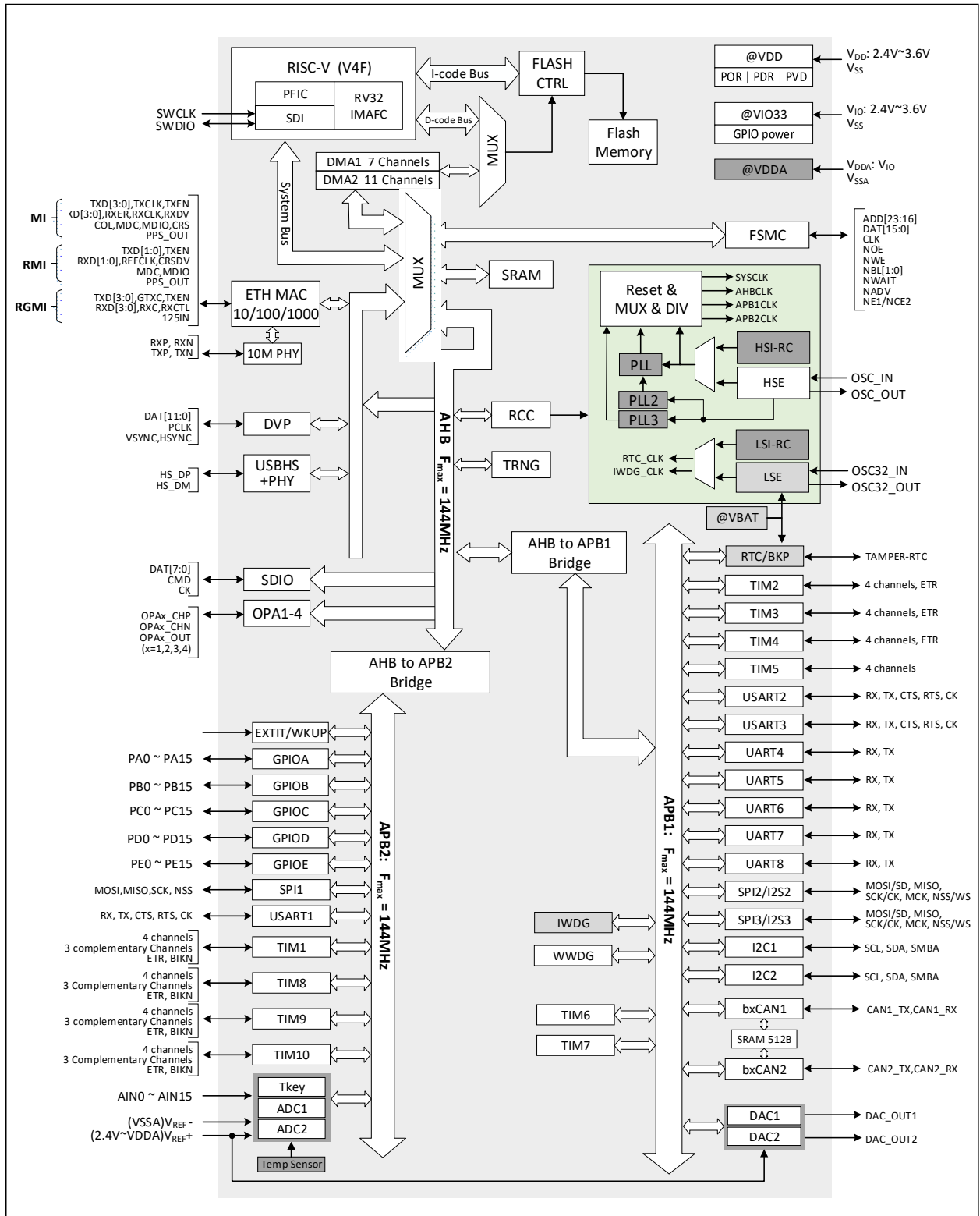

## 2.3 Memory Map

Figure 2-2 Memory address map

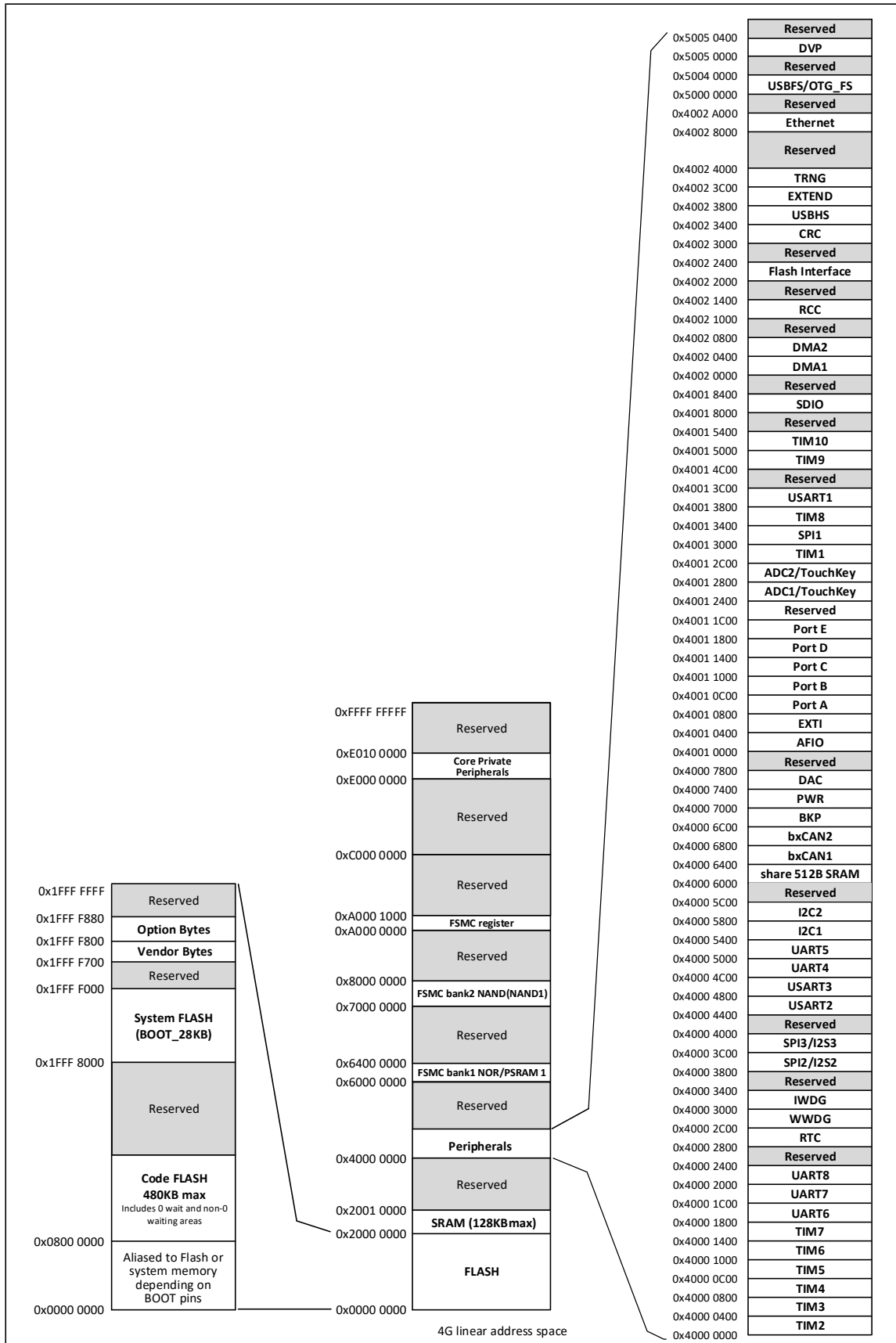



## 2.4 Clock Tree

Four groups of clock sources are introduced into the system: internal high-frequency RC oscillator (HSI), internal low-frequency RC oscillator (LSI), external high-frequency oscillator (HSE), and external low-frequency oscillator (LSE). Among them, the low-frequency clock source provides the clock reference for RTC and independent watchdog. The high-frequency clock source is directly or indirectly multiplied by the PLL and output as the system clock (SYSCLK). The system clock is then provided by each prescaler to provide the AHB domain, APB1 domain, APB2 domain peripheral control clock and sampling or output clock. Some modules need to be directly provided by the PLL clock.

Figure 2-3 CH32V305/307 clock tree block diagram

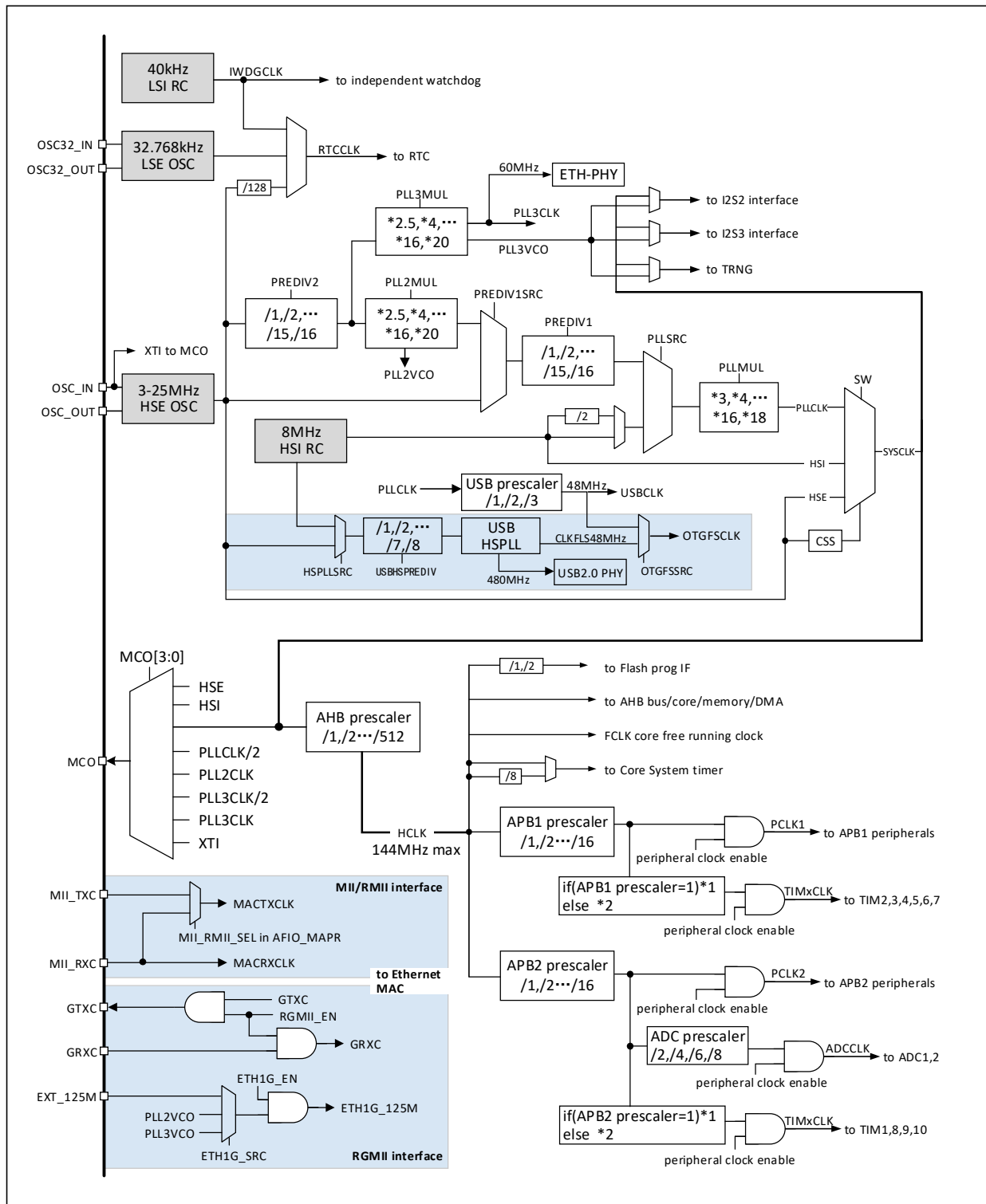
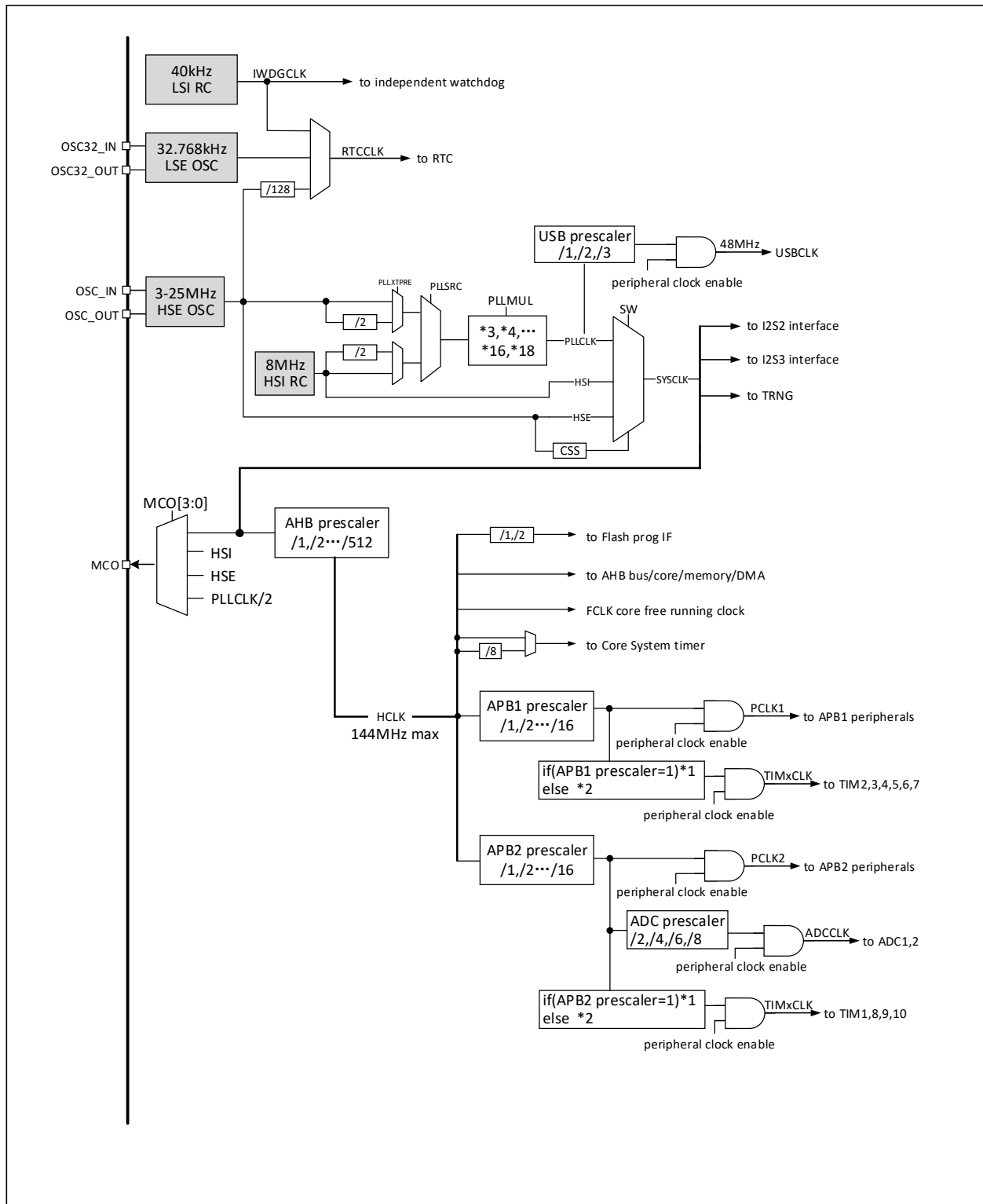

Figure 2-4 CH32V303 clock tree block diagram



Note: 1. When using USB, the CPU clock speed must be 48MHz or 96MHz or 144MHz. When system wakes up from Stop mode or Standby mode, the system will automatically select HSI as the system clock frequency.

## 2.5 Functional Description

### 2.5.1 RISC-V4F Processor

RISC-V4F supports the IMAFC subset of the RISC-V instruction set with the addition of single-precision floating-point operations. The processor is managed internally in a modular fashion and contains units such as a

fast programmable interrupt controller (PFIC), memory protection, branch prediction mode, and extended instruction support. Externally multiple buses are connected to external unit modules to enable interaction between external function modules and the core.

QingKe microprocessor can be flexibly applied in different scenarios, such as small-area low-power embedded scenarios, high-performance application operating system scenarios, etc., due to its minimal instruction set, multiple working modes, and modular customization extensions.

- Support machine and user privilege mode
- Fast Programmable Interrupt Controller (FPIC)
- Multi-level hardware interrupt stack
- 2-wire Serial debug interface
- Standard memory protection design
- Static or dynamic branch prediction, efficient jump, conflict detection
- Custom extended instructions

### 2.5.2 On-chip Memory and Boot Mode

Up to 128K bytes of built-in SRAM area, used to store data, data will be lost after power failure. The specific capacity depends on the corresponding chip model.

Up to 480K bytes of built-in program Flash memory (Code FLASH), used for user application and constant data storage, including zero-wait program run area and non-zero-wait area. The specific size depends on the corresponding chip model.

Built-in 28K byte system memory (System FLASH), used for system boot program storage (manufacturer curing boot loader).

128 bytes are used for the system non-volatile configuration information store and 128 bytes are used for the user-defined information store.

At startup, one of 3 boot modes can be selected through the boot pins (BOOT0 and BOOT1):

- Boot from program flash
- Boot from system memory
- Boot from internal SRAM

The bootloader is stored in the system memory, and the contents of the program Flash memory storage can be reprogrammed through the USART1 and USB interface.

### 2.5.3 Power Supply Scheme

- $V_{DD} = 2.4\sim 3.6V$ : provides power to some of the I/O pins and internal voltage regulators, including built-in USB PHY and Ethernet PHY.
- $V_{IO} = 2.4\sim 3.6V$ : It supplies power to most of the I/O pins and the Ethernet module, which determines the pin output high voltage amplitude. Normal work during operation, the  $V_{IO}$  voltage cannot be higher than the  $V_{DD}$  voltage.
- $V_{DDA} = 2.4\sim 3.6V$ : It supplies power to the analog part of the high-frequency RC oscillator, ADC, temperature sensor, DAC and PLL. The  $V_{DDA}$  voltage must be the same as the  $V_{IO}$  voltage (If  $V_{DD}$  is powered down and  $V_{IO}$  is live, Then  $V_{DDA}$  must be live and consistent with  $V_{IO}$ ). When using ADC,  $V_{DDA}$  must not be less than 2.4V.
- $V_{BAT} = 1.8\sim 3.6V$ : When  $V_{DD}$  is turned off, (through the internal power switch) independently powers the RTC, external low-frequency oscillator and backup registers. (Pay attention to  $V_{BAT}$  power supply)

### 2.5.4 Power Supply Monitor

This product integrates a power-on reset (POR)/power-down reset (PDR) circuit, which is always in working

condition to ensure that the system is in supply. It works when the power exceeds 2.4V; when  $V_{DD}$  is lower than the set threshold ( $V_{POR/PDR}$ ), the device is placed in the reset state without using an external reset circuit.

In addition, the system is equipped with a programmable voltage monitor (PVD), which needs to be turned on by software to compare the voltage of  $V_{DD}$  power supply with the set threshold  $V_{PVD}$ .

Turn on the corresponding edge interrupt of PVD, and you can receive interrupt notification when  $V_{DD}$  drops to the PVD threshold or rises to the PVD threshold. Refer to Chapter 4 for the values of  $V_{POR/PDR}$  and  $V_{PVD}$ .

### 2.5.5 Voltage Regulator

After reset, the regulator is automatically turned on, and there are 3 operation modes according to the application mode.

- ON mode: normal operation, providing stable core power.
- Low-power mode: When the CPU enters Stop mode, the regulator can be selected to run with low-power consumption.
- OFF mode: When the CPU enters Standby mode, it automatically switches the regulator to this mode, the voltage regulator output is in high impedance, and the core power.

The voltage regulator is always ON after reset. It is OFF in Standby mode, and the regulator output is in high impedance.

### 2.5.6 Low-power Mode

The system supports 3 low-power modes, which can be selected for low-power consumption, short start-up time and multiple wake-up events to achieve the best balance.

- Sleep mode

In Sleep mode, only the CPU clock is stopped, but all peripheral clocks are powered normally and the peripherals are in a working state. This mode is the shallowest low-power mode, but it is the fastest mode to wake-up the system.

Exit condition: any interrupt or wake-up event.

- Stop mode

In this mode, the FLASH enters low-power mode, and the PLL, HSI RC oscillator and HSE crystal oscillator are turned off. In the case of keeping the contents of SRAM and registers not lost, the Stop mode can achieve the lowest power consumption.

Exit conditions: any external interrupt/event (EXTI signal), external reset signal on NRST, IWDG reset, among which EXTI signal includes one of 16 external I/O ports, PVD output, RTC alarm clock, Ethernet wake-up signal or USB wake-up signal.

- Standby mode

In this mode, the main LDO of the system is turned off, the low-power LDO supplies power to the wake-up circuit, all other digital circuits are powered off, and the FLASH is powered off. The system wakes up from Standby mode will generate a reset, and SBF (PWR\_CSR) will be set at the same time. After waking up, check the SBF status to know the low-power mode before waking up. SBF is cleared by the CSBF (PWR\_CR) bit. In the Standby mode, the contents of 32KB of SRAM can be kept (depending on the planning and configuration before going to bed), and the contents of the backup registers are kept.

Exit conditions: any external interrupt/event (EXTI signal), external reset signal on NRST, IWDG reset, a rising edge on the WKUP pin, where EXTI signal includes one of 16 external I/O ports, RTC alarm clock, Ethernet Wake-up signal, USB.

### 2.5.7 CRC (Cyclic Redundancy Check) Calculation Unit

The CRC (cyclic redundancy check) calculation unit uses a fixed polynomial generator to generate a CRC code

from a 32-bit data word. In many applications, CRC-based technology is used to verify the consistency of data transmission or storage. Within the scope of the EN/IEC 60335-1 standard, a means of detecting flash errors is provided. The CRC calculation unit can be used to calculate the signature of the software in real time and compare it with the signature generated when the software is linked and generated.

### 2.5.8 Fast Programmable Interrupt Controller (FPIC)

The product has a built-in Fast Programmable Interrupt Controller (FPIC), which supports up to 255 interrupt vectors, and provides flexible interrupt management functions with minimal interrupt latency. The current product manages 8 core private interrupts and 88 peripheral interrupt management, and other interrupt sources are reserved. FPIC registers can be accessed in user and machine privileged modes.

- 2 individual maskable interrupts
- A non-maskable interrupt NMI
- Support hardware interrupt stack (HPE) without instruction overhead
- 4-channel vector table free interrupts (VTF)
- Vector table supports address or command mode
- Configurable interrupt nesting depth, up to 8 levels
- Support interrupt tail-chaining

### 2.5.9 External Interrupt/Event Controller (EXTI)

The external interrupt/event controller contains a total of 19 edge detectors for generating interrupt/event requests. Each interrupt line can independently configure its trigger event (rising edge or falling edge or both edges), and can be individually masked; the suspend register maintains all interrupt request states. EXTI can detect that the pulse width is smaller than the clock period of the internal APB2. Up to 80 general-purpose I/O ports can be connected to 16 external interrupt lines.

### 2.5.10 General DMA Controller

The system has built-in 2 groups of general-purpose DMA controllers, manages 18 channels in total, and flexibly handles high-speed data transmission from memory to memory, peripherals to memory, and memory to peripherals, and supports ring buffer mode. Each channel has a dedicated hardware DMA request logic to support one or more peripherals' access requests to the memory. The access priority, transfer length, source address and destination address of the transfer can be configured.

The main peripherals used by DMA include: general/advanced/basic timers TIMx, ADC, DAC, I<sup>2</sup>S, USART, I<sup>2</sup>C, SPI, and SDIO.

*Note: DMA1, DMA2 and CPU access the system SRAM after arbitration by the arbiter.*

### 2.5.11 Clock and Boot

The system clock source HSI is turned on by default. After the clock is not configured or reset, the internal 8MHz RC oscillator is used as the default CPU clock, and then an external 3~25MHz clock or PLL clock can be additionally selected. When the clock security mode is turned on, if the HSE is used as the system clock (directly or indirectly), the system clock will automatically switch to the internal RC oscillator when the external clock is detected to be invalid, and the HSE and PLL will be automatically turned off at the same time; in low-power consumption mode, the system will automatically switch to the internal RC oscillator after waking up. If the clock interrupt is enabled, the software can receive the corresponding interrupt.

Multiple prescalers are used to configure the frequency of AHB. The high-speed APB (APB2) and low-speed

APB (APB1) regions provide peripheral clocks with a maximum frequency of 144MHz. Refer to the clock tree block diagram in Figure 2-3. The clock source of the I<sup>2</sup>S unit is another dedicated PLL (PLL3), so that the I<sup>2</sup>S master clock can generate all standard sampling frequencies between 8 KHz and 192 KHz.

### 2.5.12 Real Time Clock (RTC) and Backup Registers

The RTC and the backup register are in the backup power supply area inside the system. When V<sub>DD</sub> is valid, it is powered by V<sub>DD</sub>, and when V<sub>DD</sub> is invalid, the internal power is automatically switched to the V<sub>BAT</sub> pin.

The RTC real-time clock is a set of 32-bit programmable counters, and the time base supports 20-bit prescaler for measurement in a longer period of time. The clock reference source is a high-speed external clock divided by 128 (HSE/128), external crystal low-frequency oscillator (LSE) or internal low-power RC oscillator (LSI). The LSE also has a backup power supply area, so when the LSE is selected as the RTC time base, the RTC setting and time can remain unchanged after the system resets or wakes up from Standby mode.

The backup register contains up to 42 16-bit registers, which can be used to store 84 bytes of user application data. This data can continue to be maintained after wake-up from Standby, or system Reset or power Reset. When the intrusion detection function is turned on, once the intrusion detection signal is valid, all contents in the backup register will be cleared.

### 2.5.13 Analog-to-digital Converter (ADC) and Touch Key Capacitance Detection (TKey)

The product has built-in 2 12-bit analog/digital converters (ADC), sharing up to 16 external channels and 2 internal channels for sampling. The programmable channel sampling time can realize single, continuous, scanning or discontinuous conversion. And supports dual ADC conversion mode. The analog watchdog function is provided to allow very precise monitoring of one or more selected channels for monitoring the signal voltage of the channel. It supports external event-triggered conversion, the trigger source includes the internal signal and external pin of the on-chip timer; it also supports the use of DMA operations.

ADC internal channel sampling includes 1 channel of built-in temperature sensor sampling and 1 channel of internal reference power sampling. The temperature sensor generates a voltage that varies linearly with temperature. The temperature sensor is internally connected to the IN16 input channel, which is used to convert the output of the sensor to a digital value.

The touch button capacitance detection unit provides up to 16 detection channels and reuses the external channels of the ADC module. The test results are converted into output results by the ADC module, and the touch button state is identified by software calculation.

### 2.5.14 Digital-to-analog Converter (DAC)

The product has 2 built-in 12-bit voltage output digital / analog converters (DAC), which converts 2 digital signals into 2 analog voltage signals and outputs. It supports dual DAC channels independent or synchronous conversion, and supports external event trigger conversion. The trigger source includes the internal signal of the on-chip timer and the external pin (EXTI line 9). Triangular wave and noise generation can be realized. Support the use of DMA operations.

### 2.5.15 Timer and Watchdog

The timers in the system include advanced timers, general timers, basic timers, watchdog timers, and system time base timers. The number of timers included in different products in the series is different, please refer to Table 2-2 for details.

Table 2-2 Timer comparison

Timer		Resolution	Count Type	Time Base	DMA	Function
Advanced control timer	TIM1	16 bits	Up Down Up/down	APB2 time domain 16-bit divider	Supported	PWM complementary output, single pulse output Input capture Output compare Timer count
	TIM8					
	TIM9					
	TIM10					
General-purpose timer	TIM2	16 bits	Up Down Up/down	APB1 time domain 16-bit divider	Supported	Input capture Output compare Timer count
	TIM3					
	TIM4					
	TIM5	16/32 bits				
Basic timer	TIM6	16 bits	Up	APB1 time domain 16-bit divider	Supported	Timing count
	TIM7					
Window watchdog		7 bits	Down	APB1 time domain 4 types of frequency division	Not supported	Timing Reset the system (normal work)
Independent watchdog		12 bits	Down	APB1 time domain 7 types of frequency division	Not supported	Timing Reset the system (normal work + low-power work)
SysTick timer		64 bits	Up/down	SYSCLK or SYSCLK/8	Not supported	Timing

- Advanced-control timer

The advanced control timer is a 16-bit auto-loading up/down counter with a 16-bit programmable prescaler. In addition to the complete general-purpose timer function, it can be regarded as a three-phase PWM generator distributed to 6 channels, with a complementary PWM output function with dead zone insertion, allowing the timer to be updated after a specified number of counter cycles to repeat counting cycle, braking function, etc. Many functions of the advanced control timer are the same as the general timer, and the internal structure is also the same. Therefore, the advanced control timer can cooperate with other TIM timers through the timer link function to provide synchronization or event link functions.

- General-purpose timer

The general timer is a 16-bit auto-loading up/down counter with a programmable 16-bit prescaler and 4 independent channels. Each channel supports input capture, output comparison, and PWM generation and single pulse mode output. It can also work with advanced control timers through the timer link function to provide synchronization or event link functions. In Debug mode, the counter can be frozen while the PWM outputs are disabled, thereby cutting off the switches controlled by these outputs. Any general-purpose timer can be used to generate PWM output. Each timer has an independent DMA request mechanism. These timers can also process signals from incremental encoders, as well as digital outputs from 1 to 3 Hall sensors.



- Basic timer

The basic timer is a 16-bit auto-load counter that supports a 16-bit programmable prescaler. Digital-to-analog conversion (DAC) can provide a clock and trigger the synchronization circuit of the DAC. The basic timers are independent of each other and do not share any resources with each other.

- Independent watchdog

The independent watchdog is a configurable 12-bit down counter that supports 7 frequency division factors. The clock is provided by an internal independent about 40 KHz RC oscillator (LSI); because the LSI is independent of the main clock, it can run in Stop and Standby modes. IWDG is outside the main program and can work completely independently. Therefore, it is used to reset the entire system when a problem occurs, or as a free timer to provide timeout management for the application. It can be configured as software or hardware to start the watchdog through the option byte. In Debug mode, the counter can be frozen.

- Window watchdog

The window watchdog is a 7-bit down counter and can be set to free-running. It can be used to reset the entire system when a problem occurs. It is driven by the main clock and has an early warning interrupt function; in Debug mode, the counter can be frozen.

- SysTick timer

QingKe microprocessor core comes with a 64-bit optional increasing or decreasing counter, which is used to generate SYSTICK exceptions (exception number: 15). It can be specially used in real-time operating systems to provide "heartbeat" rhythm for the system, and can also be used as a standard 64-bit counter. It has automatic reload function and programmable clock source.

## 2.5.16 Communication Interface

### 2.5.16.1 Universal Synchronous/Asynchronous Receiver Transmitter (USART)

The product provides 3 groups of Universal Synchronous/Asynchronous Receiver Transmitters (USART1, USART2, USART3), and 5 groups of Universal Asynchronous Receiver Transmitters (UART4, UART5, UART6, UART7, UART8). It supports full-duplex asynchronous communication, synchronous one-way communication and half-duplex single-wire communication. It also supports LIN (Local Interconnect Network), compatible with ISO7816 smart card protocol and IrDA SIR ENDEC transmission codec specification, and modem (CTS/RTS hardware flow control) operation. It also allows multi-processor communication. It uses a fractional baud rate generator system and supports DMA operation continuous communication.

### 2.5.16.2 Serial Peripheral Interface (SPI)

Up to 3 groups of serial peripherals interface (SPI) provide master or slave operation, dynamic switching. Support multi-master mode, full-duplex or half-duplex synchronous transmission, support basic SD card and MMC mode. Programmable clock polarity and phase, data bit width provides 8 or 16-bit selection, hardware CRC generation/check for reliable communication, and continuous communication support for DMA operation.

### 2.5.16.3 I2S (audio) Interface

Up to 2 sets of standard I2S interfaces (multiplexed with SPI2 and SPI3) operate in master or slave mode. The software can be configured to transmit frames with 16-stroke 32-bit packets, support audio sampling frequencies from 8KHz to 562.2KHz, and support four audio standards. In main mode, the master clock can be output to external DAC or CODEC (decoder) at a fixed audio sampling frequency of 256x, and DMA is supported.

#### 2.5.16.4 I2C Bus

Up to 2 I2C bus interfaces can work in multi-master mode or Slave mode, perform all I2C Bus specific timing, protocol, arbitration, etc. It supports both standard and fast speed, and is compatible with SMBus2.0.

The I2C interface provides 7-bit or 10-bit addressing, and supports dual slave addressing in 7-bit Slave mode. It integrates built-in hardware CRC generator/checker. It also supports DMA operation and supports SMBus bus version 2.0 / PMBus bus.

#### 2.5.16.5 Controller Area Network (CAN)

The CAN interface is compatible with specifications 2.0A and 2.0B (active), the baud rate is up to 1Mbits/s, and it supports time-triggered communication functions. It can receive and send standard frames with 11-bit identifiers, as well as extended frames with 29-bit identifiers. It has 3 sending mailboxes and 2 3-level deep receiving FIFOs.

Products with 2 CAN controllers share 28 configurable filters and 512 bytes of SRAM memory resources.

With 1 set of CAN controller products, there are only 14 configurable filters, and share a dedicated 512-byte SRAM memory with the USB module for data transmission and reception. When USB and CAN are used at the same time, in order to prevent access to SRAM conflicts, USB can only use the lower 384 bytes.

#### 2.5.16.6 Universal Serial Bus USB2.0 Full-speed Host/Device Controller (USBFS/OTG\_FS)

USB2.0 full-speed host controller and device controller (USBFS) follow the USB2.0 full-speed standard. It provides 16 configurable USB device endpoints and a set of host endpoints. Support control/batch/synchronization/interrupt transmission, double buffer mechanism, USB bus suspend/resume operation, and provide standby/wake-up functions. The 48MHz clock dedicated to the USBFS module is directly generated by the internal main PLL frequency division (the PLL must be 144MHz or 96MHz or 48MHz).

OTG\_FS is a dual role USB controller that supports both host-side and device-side functionality and is compatible with the On-The-Go Supplement to the USB2.0 specification. The controller can also be configured as a host-side only or device-side only controller, compatible with the USB2.0 Full Speed specification. The controller uses a 48MHz clock derived from PLL divider and key features include

- Support the USB On-The-Go Supplement (physical layer of the OTG\_FS controller), defined as an optional OTG protocol in the Revision 1.3 specification
- Software configurable USB full speed host, USB full speed/low speed device, USB dual role device
- Provide power saving function
- Support control transfer, bulk transfer, interrupt transfer, real-time/synchronous transfer
- Provide bus reset, suspend, wakeup and resume functions

#### 2.5.16.7 Universal Serial Bus USB2.0 High-speed Host/Device Controller (USBHS)

USB2.0 high-speed controller has dual roles of host controller and device controller, and has built-in USB-PHY physical layer transceiver of 480Mbps. When used as a host controller, it can support low-speed, full-speed and high-speed USB devices. When used as a device controller, it can be flexibly set to low-speed, full-speed or high-speed mode to adapt to a variety of applications. Key features include:

- Support USB 2.0, USB 1.1, USB 1.0 protocol specifications
- Support control transfer, bulk transfer, interrupt transfer, real-time/synchronous transfer
- Provide bus reset, suspend, wakeup and resume functions
- Support high-speed HUB
- Provide 16 groups of up and down transmission channels in device mode, supports configuration of 16 endpoint numbers
- All endpoints except device endpoint 0 support packets up to 1024 bytes, with double buffering available

### 2.5.16.8 Digital Video Port (DVP)

Digital Video Port (DVP) is used to connect to the camera module to obtain the image data stream. It provides 8/10/12bit parallel interface way of communication. It supports image data organized in original line and frame formats, such as YUV, RGB, etc., and also supports compressed image data streams such as JPEG format. When receiving, it mainly relies on VSYNC and HSYNC signal synchronization. Support image cropping function.

### 2.5.16.9 SDIO Host Controller

The SDIO host interface provides interfaces for the operation of multimedia cards (MMC), SD memory cards, SDIO cards, and CE-ATA devices. Three different data bus modes are supported: 1-bit (default), 4-bit and 8-bit. In 8-bit mode, the interface enables data transfer rates up to 48 MHz. currently the interface is fully compatible with the Multimedia Card System Specification 4.2 (forward compatible), SD I/O Card Specification 2.0, SD Memory Card Specification 2.0, and CE-ATA Digital Protocol Specification 1.1.

### 2.5.16.10 Flexible Static Memory Controller

The FSMC interface provides mainly synchronous or asynchronous memory interfaces, supporting SRAM, PSRAM, NOR and NAND devices. The internal AHB transfer signal is converted to a suitable external communication protocol, allowing continuous access to 8/16/32 bit data. The sampling delay time is flexibly configurable to suit different device timings.

In addition, the FSMC can also be used to interface with most graphic LCD controllers. It supports the Intel 8080 and Motorola 6800 models, making it easy to build simple graphic application environments or high-performance solutions for dedicated accelerated controllers.

### 2.5.16.11 Gigabit Ethernet controller (MAC, +10M PHY)

The product provides an IEEE802.3-2002 compliant Gigabit Ethernet controller (MAC), which acts as the data link layer. Its Link rate supports 1Gbps at the highest speed, supports gigabit and 100 megabit and speed adaptation, and provides a MII/RMII/RGMII interface to connect to external PHY chips (such as 100Mbps's industrial physical layer chip CH182). In application, combined with TCP/IP protocol stack interface to achieve the development of network products. The product also has built-in 10Mbps Ethernet PHY physical layer transceiver, which realizes Ethernet communication on a single chip. Key features include:

- Compliant with IEEE 802.3 protocol specification and design
- Provide RGMII, RMII, MII interfaces to external Ethernet PHY transceivers
- Support full-duplex operation and 10/100/1000Mbps data transfer rates
- Hardware automatic IPv4 and IPv6 packet integrity checks, IP/ICMP/UDP/TCP packet checks and computer frame length padding
- Multiple MAC address filtering modes
- External PHY can be configured and managed by SMI
- Built-in physical layer PHY of 10Mbps to simplify peripheral circuits

## 2.5.17 General-purpose Input and Output (GPIO)

The system provides 5 groups of GPIO ports with a total of 80 GPIO pins. Each pin can be configured by software as output (push-pull or open-drain), input (with or without pull-up or pull-down) or multiplexed peripheral function port. Most GPIO pins are shared with digital or analog multiplexed peripherals. Except for ports with analog input functions, all GPIO pins have high current passing capabilities. A locking mechanism is provided to freeze the IO configuration to avoid accidental writing to the I/O register.

Most of the IO pins in the system are provided by  $V_{IO}$ . Changing the  $V_{IO}$  power supply will change the high

value of the IO pin output level to adapt to the external communication interface level. Please refer to the pin description for specific pins.

### **2.5.18 Random Number Generator (RNG)**

The product has built-in a random number generator, which provides a 32-bit random number through the internal analog circuit.

### **2.5.19 Operational Amplifier/Comparator (OPA)**

The product has 4 sets of operational amplifiers, which can also be used for comparators. The internal selection is associated with ADC and TIMx peripherals, whose inputs and outputs can be selected for multiple channels by changing the configuration. Support the external analog small signal to be amplified into ADC to achieve small signal ADC conversion, can also complete the signal comparator function, the comparison results are output by GPIO or directly connected to the input channel of TIMx.

### **2.5.20 2-wire SDI Serial Debug Interface**

The core comes with a 2-wire serial debug interface (SDI), including SWDIO and SWCLK pins. The default debug interface pin function is turned on after the system is powered on or reset, and the SDI can be turned off according to the need after the main program is running.



### 3.1.2 Connectivity Device V305

#### CH32V305RBT6

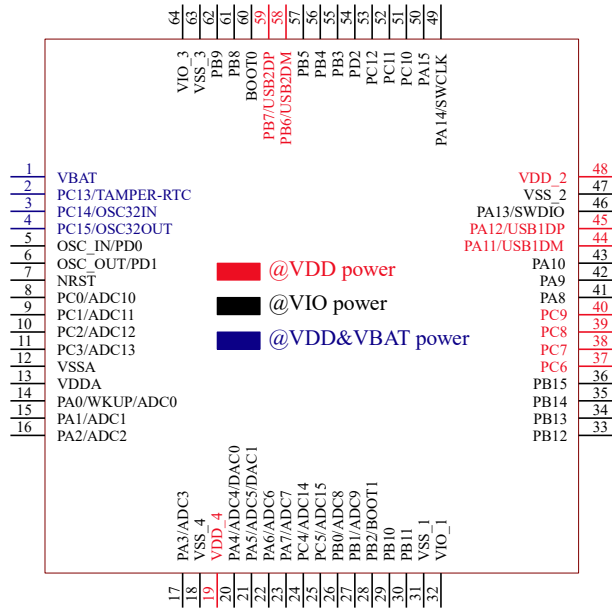

#### CH32V305GBU6

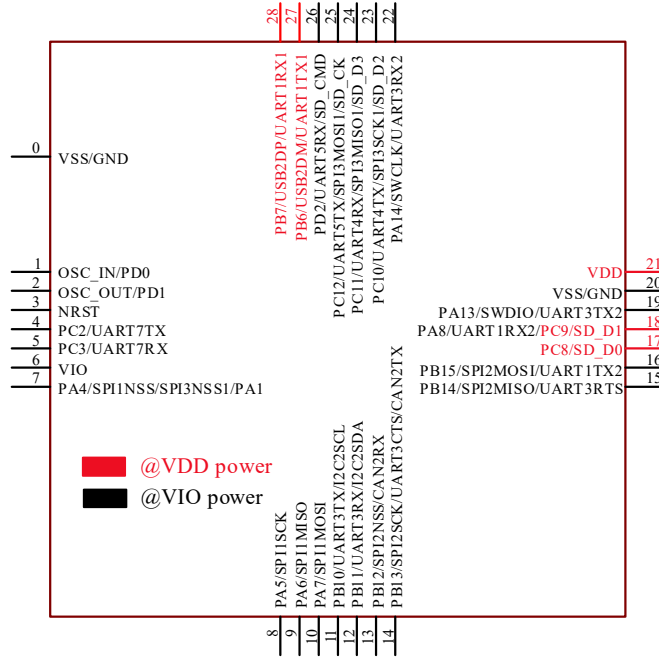

#### CH32V305FBP6

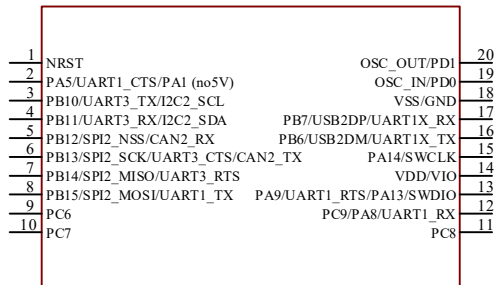

### 3.1.3 High-capacity General-purpose Device V303

CH32V303VCT6

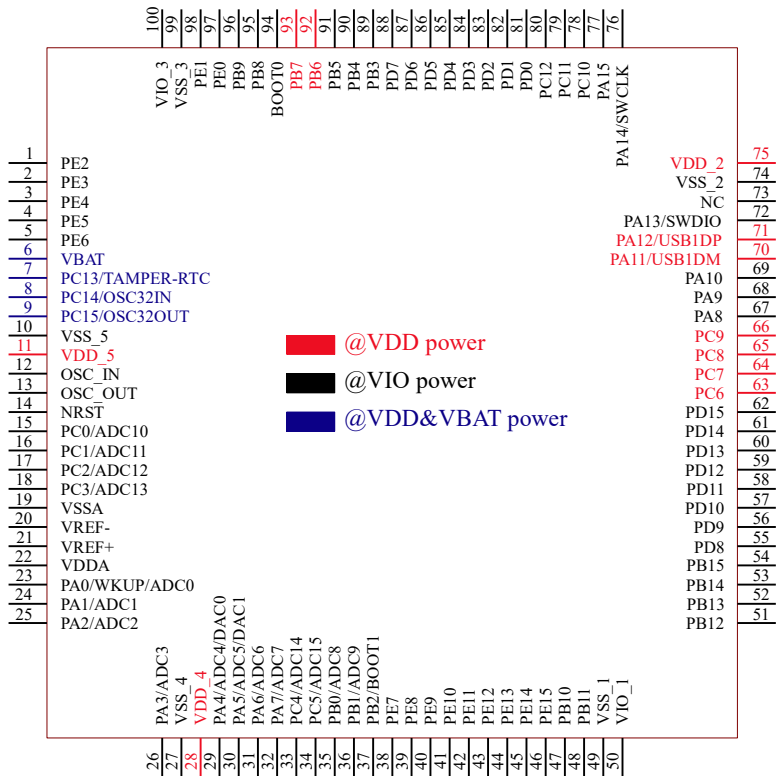

CH32V303RxT6

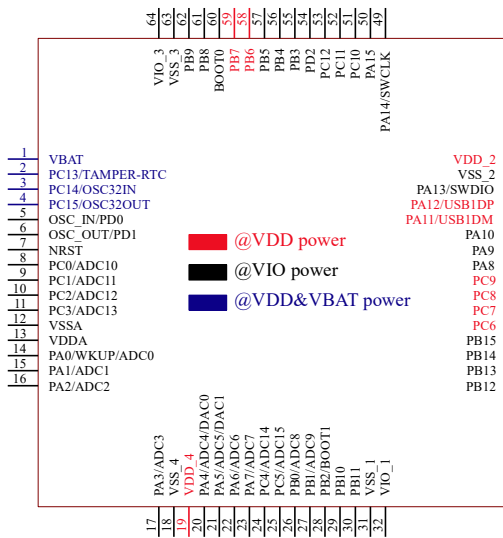

CH32V303CBT6

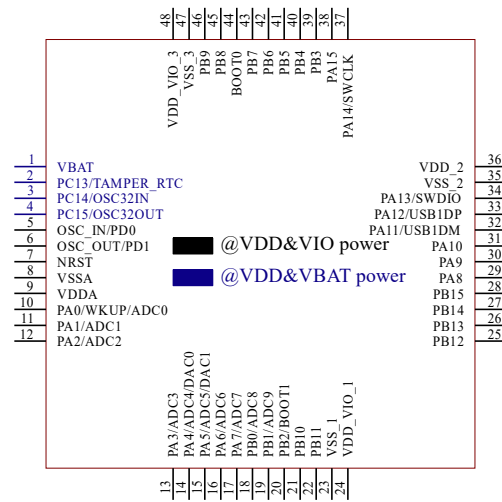

### 3.2 Pin Description

Note: The pin function in the table below refer to all functions and does not involve specific model(s). There are differences in peripheral resources between different models. Please confirm whether this function is available according to the particular model's resource table before viewing this table.

Table 3-1 Pin definitions

TSSOP2	Pin No.					Pin name	Pin type (1)	I/O level	Main function (after reset)	Default alternate function	Remapping function <sup>(12)</sup>
	QFN28	LQFP48	LQFP64	QFN68	LQFP10						
18	0 20	-	-	0	-	VSS	P	-	VSS	-	-
-	-	-	-	-	1	PE2	I/O	FT	PE2	FSMC_A23	TIM10_BKIN_2 TIM10_BKIN_3
-	-	-	-	-	2	PE3	I/O	FT	PE3	FSMC_A19	TIM10_CH1N_2 TIM10_CH1N_3
-	-	-	-	-	3	PE4	I/O	FT	PE4	FSMC_A20	TIM10_CH2N_2 TIM10_CH2N_3
-	-	-	-	-	4	PE5	I/O	FT	PE5	FSMC_A21	TIM10_CH3N_2 TIM10_CH3N_3
-	-	-	-	-	5	PE6	I/O	FT	PE6	FSMC_A22	
-	-	1	1	1	6	V <sub>BAT</sub>	P	-	V <sub>BAT</sub>		
-	-	2	2	2	7	PC13- TAMPER- RTC <sup>(2)</sup>	I/O	-	PC13 <sup>(3)</sup>	TAMPER-RTC	TIM8_CH4_1
-	-	3	3	3	8	PC14- OSC32_IN <sup>(2)</sup>	I/O/A	-	PC14 <sup>(3)</sup>	OSC32_IN	TIM9_CH4_1
-	-	4	4	4	9	PC15- OSC32_O UT <sup>(2)</sup>	I/O/A	-	PC15 <sup>(3)</sup>	OSC32_OUT	TIM10_CH4_1
-	-	-	-	-	10	V <sub>SS_5</sub>	P	-	V <sub>SS_5</sub>		
-	-	-	-	-	11	V <sub>DD_5</sub>	P	-	V <sub>DD_5</sub>		
19	1	5	5	5	12	OSC_IN	I/A	-	OSC_IN		PD0 <sup>(4)</sup>
20	2	6	6	6	13	OSC_OUT	O/A	-	OSC_OUT		PD1 <sup>(4)</sup>
1	3	7	7	7	14	NRST	I	-	NRST		
-	-	-	8	8	15	PC0	I/O/A	-	PC0	ADC_IN10 TIM9_CH1N UART6_TX ETH_RGMII_RX C	
-	-	-	9	9	16	PC1	I/O/A	-	PC1	ADC_IN11 TIM9_CH2N UART6_RX	



Pin No.						Pin name	Pin type (1)	I/O level	Main function (after reset)	Default alternate function	Remapping function <sup>(12)</sup>
TSSOP2	QFN28	LQFP48	LQFP64	QFN68	LQFP10						
										ETH_MII_MDC ETH_RMII_MDC ETH_RGMII_RX CTL	
-	4	-	10	10	17	PC2	I/O/A	-	PC2	ADC_IN12 TIM9_CH3N UART7_TX OPA3_CH1N ETH_MII_TXD2 ETH_RGMII_RX D0	
-	5	-	11	11	18	PC3	I/O/A	-	PC3	ADC_IN13 TIM10_CH3 UART7_RX OPA4_CH1N ETH_MII_TX_C LK ETH_RGMII_RX D1	
-	-	8	12	12	19	V <sub>SSA</sub>	P	-	V <sub>SSA</sub>		
-	-	-	-	-	20	V <sub>REF-</sub>	P	-	V <sub>REF-</sub>		
-	-	-	-	-	21	V <sub>REF+</sub>	P	-	V <sub>REF+</sub>		
-	-	9	13	13	22	V <sub>DDA</sub>	P	-	V <sub>DDA</sub>		
-	-	10	14	14	23	PA0- WKUP	I/O/A	-	PA0	WKUP USART2_CTS ADC_IN0 TIM2_CH1 <sup>(13)</sup> TIM2_ETR <sup>(13)</sup> TIM5_CH1 TIM8_ETR OPA4_OUT0 ETH_MII_CRS ETH_RGMII_RX D2	TIM2_CH1_2 <sup>(13)</sup> TIM2_ETR_2 <sup>(13)</sup> TIM8_ETR_1
2	7	11	15	15	24	PA1 <sup>(14)</sup>	I/O/A	-	PA1	USART2_RTS ADC_IN1 TIM5_CH2 TIM2_CH2 OPA3_OUT0 ETH_MII_RX_C	TIM2_CH2_2 TIM9_BKIN_1

Pin No.						Pin name	Pin type (1)	I/O level	Main function (after reset)	Default alternate function	Remapping function <sup>(12)</sup>
TSSOP2	QFN28	LQFP48	LQFP64	QFN68	LQFP10						
										LK ETH_RMII_REF _CLK ETH_RGMII_RX D3	
-	-	12	16	16	25	PA2	I/O/A	-	PA2	USART2_TX TIM5_CH3 ADC_IN2 TIM2_CH3 TIM9_CH1 TIM9_ETR OPA2_OUT0 ETH_MII_MDIO ETH_RMII_MDI O ETH_RGMII_GT XC	TIM2_CH3_1 TIM9_CH1_1 TIM9_ETR_1
-	-	-	-	17	-	V <sub>IO_4</sub>	P	-	V <sub>IO_4</sub>		
-	-	13	17	19	26	PA3	I/O/A	-	PA3	USART2_RX TIM5_CH4 ADC_IN3 TIM2_CH4 TIM9_CH2 OPA1_OUT0 ETH_MII_COL ETH_RGMII_TX EN	TIM2_CH4_1 TIM9_CH2_1
-	-	-	18	-	27	V <sub>SS_4</sub>	P	-	V <sub>SS_4</sub>		
-	-	-	19	-	28	V <sub>DD_4</sub>	P	-	V <sub>DD_4</sub>		
-	7	14	20	20	29	PA4	I/O/A	-	PA4	SPI1_NSS USART2_CK ADC_IN4 DAC1_OUT TIM9_CH3 DVP_HSYNC	SPI3_NSS_1 I2S3_WS_1 TIM9_CH3_1
2	8	15	21	21	30	PA5 <sup>(14)</sup>	I/O/A	-	PA5	SPI1_SCK ADC_IN5 DAC2_OUT OPA2_CH1N DVP_VSYNC	TIM10_CH1N_1 USART1_CTS_2 USART1_CK_3

Pin No.						Pin name	Pin type (1)	I/O level	Main function (after reset)	Default alternate function	Remapping function <sup>(12)</sup>
TSSOP2	QFN28	LQFP48	LQFP64	QFN68	LQFP10						
-	9	16	22	22	31	PA6	I/O/A	-	PA6	SPI1_MISO TIM8_BKIN ADC_IN6 TIM3_CH1 OPA1_CH1N DVP_PCLK	TIM1_BKIN_1 USART1_TX_3 UART7_TX_1 TIM10_CH2N_1
-	10	17	23	23	32	PA7	I/O/A	-	PA7	SPI1_MOSI TIM8_CH1N ADC_IN7 TIM3_CH2 OPA2_CH1P ETH_MII_RX_D V ETH_RMII_CRS _DV ETH_RGMII_TX D0	TIM1_CH1N_1 USART1_RX_3 UART7_RX_1 TIM10_CH3N_1
-	-	-	24	24	33	PC4	I/O/A	-	PC4	ADC_IN14 TIM9_CH4 UART8_TX OPA4_CH1P ETH_MII_RXD0 ETH_RMII_RXD 0 ETH_RGMII_TX D1	USART1_CTS_3
-	-	-	25	25	34	PC5	I/O/A	-	PC5	ADC_IN15 TIM9_BKIN UART8_RX OPA3_CH1P ETH_MII_RXD1 ETH_RMII_RXD 1 ETH_RGMII_TX D2	USART1_RTS_3
-	-	18	26	26	35	PB0	I/O/A	-	PB0	ADC_IN8 TIM3_CH3 TIM8_CH2N OPA1_CH1P ETH_MII_RXD2 ETH_RGMII_TX	TIM1_CH2N_1 TIM3_CH3_2 TIM9_CH1N_1 UART4_TX_1

Pin No.						Pin name	Pin type (1)	I/O level	Main function (after reset)	Default alternate function	Remapping function <sup>(12)</sup>
TSSOP2	QFN28	LQFP48	LQFP64	QFN68	LQFP10						
										D3	
-	-	19	27	27	36	PB1	I/O/A	-	PB1	ADC_IN9 TIM3_CH4 TIM8_CH3N OPA4_CH0N ETH_MII_RXD3 ETH_RGMII_125 IN	TIM1_CH3N_1 TIM3_CH4_2 TIM9_CH2N_1 UART4_RX_1
-	-	20	28	28	37	PB2 <sup>(5)</sup>	I/O	FT	PB2 BOOT1 <sup>(5)</sup>	OPA3_CH0N	TIM9_CH3N_1
-	-	-	-	-	38	PE7	I/O/A	FT	PE7	FSMC_D4 OPA3_OUT1	TIM1_ETR_3
-	-	-	-	-	39	PE8	I/O/A	FT	PE8	FSMC_D5 OPA4_OUT1	TIM1_CH1N_3 UART5_TX_2 UART5_TX_3
-	-	-	-	-	40	PE9	I/O	FT	PE9	FSMC_D6	TIM1_CH1_3 UART5_RX_2 UART5_RX_3
-	-	-	-	-	41	PE10	I/O	FT	PE10	FSMC_D7	TIM1_CH2N_3 UART6_TX_2 UART6_TX_3
-	-	-	-	-	42	PE11	I/O	FT	PE11	FSMC_D8	TIM1_CH2_3 UART6_RX_2 UART6_RX_3
-	-	-	-	-	43	PE12	I/O	FT	PE12	FSMC_D9	TIM1_CH3N_3 UART7_TX_2 UART7_TX_3
-	-	-	-	-	44	PE13	I/O	FT	PE13	FSMC_D10	TIM1_CH3_3 UART7_RX_2 UART7_RX_3
-	-	-	-	-	45	PE14	I/O/A	FT	PE14	FSMC_D11 OPA2_OUT1	TIM1_CH4_3 UART8_TX_2 UART8_TX_3
-	-	-	-	-	46	PE15	I/O/A	FT	PE15	FSMC_D12 OPA1_OUT1	TIM1_BKIN_3 UART8_RX_2 UART8_RX_3
3	11	21	29	29	47	PB10	I/O/A	FT	PB10	I2C2_SCL USART3_TX OPA2_CH0N ETH_MII_RX_E	TIM2_CH3_2 TIM2_CH3_3 TIM10_BKIN_1

Pin No.						Pin name	Pin type (1)	I/O level	Main function (after reset)	Default alternate function	Remapping function <sup>(12)</sup>
TSSOP2	QFN28	LQFP48	LQFP64	QFN68	LQFP10						
										R	
4	12	22	30	30	48	PB11	I/O/A	FT	PB11	I2C2_SDA USART3_RX OPA1_CH0N ETH_MII_TX_E N ETH_RMII_TX_ EN	TIM2_CH4_2 TIM2_CH4_3 TIM10_ETR_1
-	-	23	31	18	49	V <sub>SS_1</sub>	P		V <sub>SS_1</sub>		
-	-	-	32	31	50	V <sub>IO_1</sub>	P		V <sub>IO_1</sub>		
-	-	24	-	-	-	V <sub>DD_IO_1</sub>	P		V <sub>DD_IO_1</sub>		
-	-	-	-	32	-	V <sub>DD_1</sub>	P		V <sub>DD_1</sub>		
5	13	25	33	35	51	PB12	I/O/A	FT	PB12	SPI2_NSS I2S2_WS I2C2_SMBA USART3_CK TIM1_BKIN OPA4_CH0P CAN2_RX ETH_MII_TXD0 ETH_RMII_TXD 0 ETH_RGMII_M DC	
6	14	26	34	36	52	PB13	I/O/A	FT	PB13	SPI2_SCK I2S2_CK USART3_CTS TIM1_CH1N OPA3_CH0P CAN2_TX ETH_MII_TXD1 ETH_RMII_TXD 1 ETH_RGMII_M DIO	USART3_CTS_1
7	15	27	35	37	53	PB14	I/O/A	FT	PB14	SPI2_MISO TIM1_CH2N USART3_RTS OPA2_CH0P SDIO_D0 <sup>(7)</sup>	USART3_RTS_1

Pin No.						Pin name	Pin type (1)	I/O level	Main function (after reset)	Default alternate function	Remapping function <sup>(12)</sup>
TSSOP2	QFN28	LQFP48	LQFP64	QFN68	LQFP10						
8	16	28	36	38	54	PB15	I/O/A	FT	PB15	SPI2_MOSI I2S2_SD TIM1_CH3N OPA1_CH0P SDIO_D1 <sup>(7)</sup>	USART1_TX_2
-	-	-	-	33	55	PD8	I/O	FT	PD8	FSMC_D13	USART3_TX_3 TIM9_CH1N_2 TIM9_CH1N_3 ETH_MII_RX_D V_1 ETH_RMII_CRS _DV_1
-	-	-	-	34	56	PD9	I/O	FT	PD9	FSMC_D14	USART3_RX_3 TIM9_CH1_2 TIM9_ETR_2 TIM9_CH1_3 TIM9_ETR_3 ETH_MII_RXD0 _1 ETH_RMII_RXD 0_1
-	-	-	-	-	57	PD10	I/O	FT	PD10	FSMC_D15	USART3_CK_2 USART3_CK_3 TIM9_CH2N_2 TIM9_CH2N_3 ETH_MII_RXD1 _1 ETH_RMII_RXD 1_1
-	-	-	-	-	58	PD11	I/O	FT	PD11	FSMC_A16	USART3_CTS_2 USART3_CTS_3 TIM9_CH2_2 TIM9_CH2_3 ETH_MII_RXD2 _1
-	-	-	-	-	59	PD12	I/O	FT	PD12	FSMC_A17	TIM4_CH1_1 TIM9_CH3N_2 TIM9_CH3N_3 USART3_RTS_3 ETH_MII_RXD3 USART3_RTS_2

Pin No.						Pin name	Pin type (1)	I/O level	Main function (after reset)	Default alternate function	Remapping function <sup>(12)</sup>
TSSOP2	QFN28	LQFP48	LQFP64	QFN68	LQFP10						
-	-	-	-	-	60	PD13	I/O	FT	PD13	FSMC_A18	TIM4_CH2_1 TIM9_CH3_2 TIM9_CH3_3
-	-	-	-	-	61	PD14	I/O	FT	PD14	FSMC_D0	TIM4_CH3_1 TIM9_BKIN_2 TIM9_BKIN_3
-	-	-	-	-	62	PD15	I/O	FT	PD15	FSMC_D1	TIM4_CH4_1 TIM9_CH4_2 TIM9_CH4_3
9	-	-	37	39	63	PC6	I/O	FT	PC6	I2S2_MCK TIM8_CH1 SDIO_D6 ETH_RXP	TIM3_CH1_3
10	-	-	38	40	64	PC7	I/O	FT	PC7	I2S3_MCK <sup>(11)(16)</sup> TIM8_CH2 SDIO_D7 ETH_RXN	TIM3_CH2_3
11	17	-	39	41	65	PC8	I/O	FT	PC8	TIM8_CH3 SDIO_D0 ETH_TXP DVP_D2	TIM3_CH3_3
12	18	-	40	42	66	PC9 <sup>(6)</sup>	I/O	FT	PC9	TIM8_CH4 SDIO_D1 ETH_TXN DVP_D3	TIM3_CH4_3
		29	41	43	67	PA8 <sup>(6)</sup>	I/O	FT	PA8	USART1_CK TIM1_CH1 MCO I2S3_MCK <sup>(11)(16)</sup>	USART1_CK_1 USART1_RX_2 TIM1_CH1_1
13	-	30	42	44	68	PA9 <sup>(15)</sup>	I/O	FT	PA9	USART1_TX TIM1_CH2 OTG_FS_VBUS DVP_D0 SPI3_MOSI <sup>(10)</sup> I2S3_SD <sup>(10)(11)</sup>	USART1_RTS_2 TIM1_CH2_1
-	-	31	43	45	69	PA10	I/O	FT	PA10	USART1_RX TIM1_CH3 OTG_FS_ID DVP_D1	USART1_CK_2 TIM1_CH3_1
-	-	32	44	46	70	PA11	I/O/A	FT	PA11	USART1_CTS	USART1_CTS_1

Pin No.						Pin name	Pin type (1)	I/O level	Main function (after reset)	Default alternate function	Remapping function <sup>(12)</sup>
TSSOP2	QFN28	LQFP48	LQFP64	QFN68	LQFP10						
										CAN1_RX TIM1_CH4 OTG_FS_DM	TIM1_CH4_1
-		33	45	47	71	PA12	I/O/A	FT	PA12	USART1_RTS CAN1_TX TIM1_ETR TIM10_CH1N OTG_FS_DP	USART1_RTS_1 TIM1_ETR_1
13	19	34	46	48	72	PA13 <sup>(15)</sup>	I/O	FT	SWDIO	TIM10_CH2N	PA13 TIM8_CH1N_1 USART3_TX_2
-	-	-	-	-	73	未使用					
-	-	35	47	49	74	V <sub>SS_2</sub>	P	-	V <sub>SS_2</sub>		
-	-	36	48	50	75	V <sub>DD_2</sub>	P	-	V <sub>DD_2</sub>		
-	-	-	-	51	-	V <sub>IO_2</sub>	P	-	V <sub>IO_2</sub>		
15	22	37	49	52	76	PA14	I/O	FT	SWCLK	TIM10_CH3N	TIM8_CH2N_1 UART8_TX_1 PA14 USART3_RX_2
-	-	38	50	53	77	PA15	I/O	FT	PA15	SPI3_NSS I2S3_WS <sup>(11)</sup>	TIM2_CH1_1 <sup>(13)</sup> TIM2_ETR_1 <sup>(13)</sup> TIM2_CH1_3 <sup>(13)</sup> TIM2_ETR_3 <sup>(13)</sup> SPI1_NSS_1 TIM8_CH3N_1 UART8_RX_1
-	23	-	51	54	78	PC10	I/O	FT	PC10	UART4_TX SDIO_D2 TIM10_ETR DVP_D8	USART3_TX_1 SPI3_SCK_1 I2S3_CK_1
-	24	-	52	55	79	PC11	I/O	FT	PC11	UART4_RX SDIO_D3 TIM10_CH4 DVP_D4	USART3_RX_1 SPI3_MISO_1
-	25	-	53	56	80	PC12	I/O	FT	PC12	UART5_TX SDIO_CK TIM10_BKIN DVP_D9	USART3_CK_1 SPI3_MOSI_1 I2S3_SD_1
-	1	-	-	-	81	PD0	I/O/A	FT	PD0	FSMC_D2	CAN1_RX_3 TIM10_ETR_2



Pin No.						Pin name	Pin type (1)	I/O level	Main function (after reset)	Default alternate function	Remapping function <sup>(12)</sup>
TSSOP2	QFN28	LQFP48	LQFP64	QFN68	LQFP10						
											TIM10_ETR_3
-	2	-	-	-	82	PD1	I/O/A	FT	PD1	FSMC_D3	CAN1_TX_3 TIM10_CH1_2 TIM10_CH1_3
-	26	-	54	57	83	PD2	I/O	FT	PD2	TIM3_ETR UART5_RX SDIO_CMD DVP_D11 FSMC_NADV <sup>(9)</sup>	TIM3_ETR_2 TIM3_ETR_3
-	-	-	-	-	84	PD3	I/O	FT	PD3	FSMC_CLK	USART2_CTS_1 TIM10_CH2_2 TIM10_CH2_3
-	-	-	-	-	85	PD4	I/O	FT	PD4	FSMC_NOE	USART2_RTS_1
-	-	-	-	-	86	PD5	I/O	FT	PD5	FSMC_NWE	USART2_TX_1 TIM10_CH3_2 TIM10_CH3_3
-	-	-	-	-	87	PD6	I/O	FT	PD6	FSMC_NWAIT DVP_D10	USART2_RX_1
-	-	-	-	-	88	PD7	I/O	FT	PD7	FSMC_NE1 FSMC_NCE2	USART2_CK_1 TIM10_CH4_2 TIM10_CH4_3
-	-	39	55	58	89	PB3	I/O	FT	PB3	SPI3_SCK I2S3_CK <sup>(11)</sup> DVP_D5 <sup>(8)</sup>	TIM2_CH2_1 TIM2_CH2_3 SPI1_SCK_1 TIM10_CH1_1
-	-	40	56	59	90	PB4	I/O	FT	PB4	SPI3_MISO	TIM3_CH1_2 SPI1_MISO_1 UART5_TX_1 TIM10_CH2_1
-	-	41	57	60	91	PB5	I/O	FT	PB5	I2C1_SMBA SPI3_MOSI <sup>(10)</sup> I2S3_SD <sup>(10)(11)</sup> ETH_MII_PPS_O UT ETH_RMII_PPS_ OUT	TIM3_CH2_2 SPI1_MOSI_1 CAN2_RX_1 TIM10_CH3_1 UART5_RX_1
16	27	42	58	61	92	PB6	I/O	FT	PB6	I2C1_SCL TIM4_CH1 USBFS_DM DVP_D5	USART1_TX_1 CAN2_TX_1 TIM8_CH1_1

Pin No.						Pin name	Pin type ( <sup>1</sup> )	I/O level	Main function (after reset)	Default alternate function	Remapping function( <sup>12</sup> )
TSSOP2	QFN28	LQFP48	LQFP64	QFN68	LQFP10						
										USBHS_DM	
17	28	43	59	62	93	PB7	I/O	FT	PB7	I2C1_SDA FSMC_NADV TIM4_CH2 USBFS_DP USBHS_DP	USART1_RX_1 TIM8_CH2_1
-	-	44	60	63	94	BOOT0 <sup>(5)</sup>	I	-	BOOT0 <sup>(5)</sup>		
-	-	45	61	64	95	PB8	I/O/A	FT	PB8	TIM4_CH3 SDIO_D4 TIM10_CH1 DVP_D6 ETH_MII_TXD3	I2C1_SCL_1 CAN1_RX_2 UART6_TX_1 TIM8_CH3_1
-	-	46	62	65	96	PB9	I/O/A	FT	PB9	TIM4_CH4 SDIO_D5 TIM10_CH2 DVP_D7	I2C1_SDA_1 CAN1_TX_2 UART6_RX_1 TIM8_BKIN_1
-	-	-	-	66	97	PE0	I/O	FT	PE0	TIM4_ETR FSMC_NBL0	TIM4_ETR_1 UART4_TX_2 UART4_TX_3
-	-	-	-	-	98	PE1	I/O	FT	PE1	FSMC_NBL1	UART4_RX_2 UART4_RX_3
-	-	47	63	-	99	V <sub>SS_3</sub>	P	-	V <sub>SS_3</sub>		
-	-	-	64	67	100	V <sub>IO_3</sub>	P	-	V <sub>IO_3</sub>		
-	-	-	-	68	-	V <sub>DD_3</sub>	P	-	V <sub>DD_3</sub>		
-	-	48	-	-	-	V <sub>DD_IO_3</sub>	P	-	V <sub>DD_IO_3</sub>		
14	21	-	-	-	-	V <sub>DD</sub>	P	-	V <sub>DD</sub>		
	6	-	-	-	-	V <sub>IO</sub>	P	-	V <sub>IO</sub>		

Note 1: Abbreviations in the table

*I* = TTL/CMOS Schmitt input;

*O* = CMOS tri-state output;

*A* = analog signal input or output;

*P* = power;

*FT* = 5V tolerance;

*ANT* = RF signal input and output (antenna).

Note 2: When the backup area is powered by V<sub>DD</sub> (internal analog switch connected to V<sub>DD</sub>): PC14 and PC15 can be used for GPIO or LSE pins, PC13 can be used as general-purpose I/O port, TAMPER pin, RTC calibration clock, RTC alarm or seconds output; when used as output pin, it can only work in 2MHz mode with a maximum drive load of 30pF; when the backup area is powered by V<sub>BAT</sub> (analog switch connected to BAT after

$V_{DD}$  disappears): PC14 and PC15 can only be used for LSE pin, PC13 can be used as TAMPER pin, RTC alarm or seconds output.

Note 3: These pins are in the main function state when the backup area is powered on for the first time. Even after reset, the state of these pins is controlled by the backup area registers (these registers will not be reset by the main reset system). For specific information on how to control these I/O ports, please refer to the relevant chapters on the battery backup area and BKP register in the CH32FV2x\_V3xRM datasheet.

Note 4: Pin 5 and pin 6 of those in LQFP64M package are configured as OSC\_IN and OSC\_OUT function pins by default after chip reset. Software can reconfigure these 2 pins as PD0 and PD1. But for those in LQFP100 package, since PD0 and PD1 are inherent functional pins, there is no need to remap settings by software. For more detailed information, please refer to the chapters on Alternate Function I/O and Debug Setting in the CH32FV2x\_V3xRM datasheet.

Note 5: For devices without the BOOT0 pinout, they are pulled down to GND internally. For devices with the BOOT0 pinout but no BOOT1/PB2 pinout, BOOT1/PB2 is pulled down to GND internally. In this case, it is recommended that the BOOT1/PB2 pinout is set to input pull-down mode if a device goes into the low-power mode and configures I/O port state, to avoid generating extra current.

Note 6: For CH32V305FBP6 and CH32V305GBU6 chips, the PA8 and PC9 pins are shorted inside the chip, it is prohibited to configure both IOs as output functions, pay attention to the pin state if there are power consumption requirements.

Note 7: SDIO\_D0 and SDIO\_D1 are mapped to PC8 and PC9 by default. only for the products with the penultimate fifth bit of the lot number greater than 1, SDIO\_D0 and SDIO\_D1 are mapped to PB14 and PB15 when bit[14]ETHMACEN=1 and bit[10]SDIOEN=1 of register RCC\_AHBPCENR.

Note 8: DVP\_D5 is mapped to PB6 by default. only for products with the penultimate fifth digit of the lot number greater than 1, when bit[13]DVPEN=1 with bit[11]USBHSEN=1 of register RCC\_AHBPCENR and bit[2]RB\_UC\_RST\_SIE=0 of R8\_USB\_CTRL, DVP\_D5 is mapped to PB3.

Note 9: FSMC\_NADV maps to PB7 by default. only for products with the penultimate fifth digit of the lot number greater than 1, when bit[8]FSMCEN=1 and bit[11]USBHSEN=1 of register RCC\_AHBPCENR and bit[2]RB\_UC\_RST\_SIE=0 of R8\_USB\_CTRL, FSMC\_NADV maps to PD. NADV is mapped to PD2.

Note 10: SPI3\_MOSI (I2S3\_SD) is mapped to PB5 by default. only for products with the penultimate digit of the lot number greater than 2, when using SPI3, the default mapping of SPI3\_MOSI (I2S3\_SD) is automatically changed to PA9 if both 10M Ethernet and the I2S function of SPI3 are used.

Note 11: For products with a lot number with a penultimate digit of 2, the I2S3 default pin function is not available when Ethernet is used, and the chip select signal of the SPI3 default pin is not available.

Note 12: The value after the underscore of the remap function indicates the configuration value of the corresponding bit in the AFIO register. For example, UART4\_RX\_3 indicates that the corresponding bit in the AFIO register is configured as 11b.

Note 13: TIM2\_CH1 and TIM2\_ETR share a common pin, but cannot be used at the same time.

Note 14 and Note 15: For CH32V305FBP6 chip, PA5 and PA1 pins are short-circuited inside the chip, prohibiting both IOs to be configured as output function; PA9 and PA13 pins are short-circuited inside the chip, prohibiting both IOs to be configured as output function; pay attention to the pin status if there is power consumption requirement.

Note 16: I2S3\_MCK is mapped to PC7 by default, only for products with lot number whose penultimate digit is greater than 2. If 10M Ethernet and I2S3 are used at the same time, the default mapping of I2S3\_MCK is automatically changed to PA8.

### 3.3 Pin Alternate Functions

Note: The pin function in the table below refer to all functions and does not involve specific model(s). There are differences in peripheral resources between different models. Please confirm whether this function is available according to the particular model's resource table before viewing this table.

Table 3-2 Pin alternate and remapping functions

Alternate Pin	ADC DAC	TIM1 8/9/10	TIM2 3/4/5	UART USART	USB	SYS	I2C	SPI I2S	ETH	FSMC SDIO	DVP	OPA	CAN
PA0	ADC_IN0	TIM8_ETR TIM8_ETR_1	TIM2_CH1 TIM2_ETR TIM2_CH1_2 TIM2_ETR_2 TIM5_CH1	USART2_CTS		WKUP			ETH_MII_CRS ETH_RGMII_RXD2			OPA4_OUT0	
PA1	ADC_IN1		TIM2_CH2 TIM2_CH2_2 TIM5_CH2 TIM9_BKIN_1	USART2_RTS					ETH_MII_RX_CLK ETH_RMII_REF_CLK ETH_RGMII_RXD3			OPA3_OUT0	
PA2	ADC_IN2	TIM9_CH1 TIM9_CH1_1 TIM9_ETR TIM9_ETR_1	TIM2_CH3 TIM2_CH3_1 TIM5_CH3	USART2_TX					ETH_MII_MDIO ETH_RMII_MDIO ETH_RGMII_GTXC			OPA2_OUT0	
PA3	ADC_IN3	TIM9_CH2 TIM9_CH2_1	TIM2_CH4 TIM2_CH4_1 TIM5_CH4	USART2_RX					ETH_MII_COL ETH_RGMII_TXEN			OPA1_OUT0	
PA4	ADC_IN4 DAC1_OUT	TIM9_CH3 TIM9_CH3_1		USART2_CK				SPI1_NSS SPI3_NSS_1 I2S3_WS_1			DVP_HSYNC		
PA5	ADC_IN5 DAC2_OUT	TIM10_CH1N_1		USART1_CTS_2 USART1_CK_3				SPI1_SCK			DVP_VSYNC	OPA2_CH1N	
PA6	ADC_IN6	TIM1_BKIN_1 TIM8_BKIN TIM10_CH2N_1	TIM3_CH1	USART1_TX_3 UART7_TX_1				SPI1_MISO			DVP_PCLK	OPA1_CH1N	
PA7	ADC_IN7	TIM1_CH1N_1 TIM8_CH1N TIM10_CH3N_1	TIM3_CH2	USART1_RX_3 UART7_RX_1				SPI1_MOSI	ETH_MII_RX_DV ETH_RMII_CRS_DV ETH_RGMII_TXD0			OPA2_CH1P	
PA8		TIM1_CH1 TIM1_CH1_1		USART1_CK USART1_CK_1 USART1_RX_2		MCO		I2S3_MCK <sup>(2)</sup>					
PA9		TIM1_CH2 TIM1_CH2_1		USART1_TX USART1_RTS_2	OTG_FS_VBUS			SPI3_MOSI <sup>(1)</sup> I2S3_SD <sup>(1)</sup>			DVP_D0		
PA10		TIM1_CH3 TIM1_CH3_1		USART1_RX USART1_CK_2	OTG_FS_ID						DVP_D1		
PA11		TIM1_CH4 TIM1_CH4_1		USART1_CTS USART1_CTS_1	OTG_FS_DM								CAN1_RX
PA12		TIM1_ETR TIM1_ETR_1 TIM10_CH1N		USART1_RTS USART1_RTS_1	OTG_FS_DP								CAN1_TX
PA13		TIM8_CH1N_1 TIM10_CH2N		USART3_TX_2		SWDIO							
PA14		TIM8_CH2N_1 TIM10_CH3N		UART8_TX_1 USART3_RX_2		SWCLK							
PA15		TIM8_CH3N_1	TIM2_CH1_1 TIM2_ETR_1 TIM2_CH1_3 TIM2_ETR_3	UART8_RX_1				SPI1_NSS_1 SPI3_NSS I2S3_WS					
PB0	ADC_IN8	TIM1_CH2N_1 TIM8_CH2N TIM9_CH1N_1	TIM3_CH3 TIM3_CH3_2	UART4_TX_1					ETH_MII_RXD2 ETH_RGMII_TXD3			OPA1_CH1P	
PB1	ADC_IN9	TIM1_CH3N_1 TIM8_CH3N TIM9_CH2N_1	TIM3_CH4 TIM3_CH4_2	UART4_RX_1					ETH_MII_RXD3 ETH_RGMII_1251N			OPA4_CH0N	
PB2		TIM9_CH3N_1				BOOT1						OPA3_CH0N	
PB3		TIM10_CH1_1	TIM2_CH2_1					SPI1_SCK_1			DVP_D5		

Alternate Pin	ADC DAC	TIM1 8/9/10	TIM2 3/4/5	UART USART	USB	SYS	I2C	SPI I2S	ETH	FSMC SDIO	DVP	OPA	CAN
			TIM2_CH2_3					SPI3_SCK I2S3_CK					
PB4		TIM10_CH2_1	TIM3_CH1_2	UART5_TX_1				SPI1_MISO_1 SPI3_MISO					
PB5		TIM10_CH3_1	TIM3_CH2_2	UART5_RX_1			I2C1_SMBA	SPI1_MOSI_1 SPI3_MOSI <sup>(1)</sup> I2S3_SD <sup>(1)</sup>	ETH_MII_PPS_OUT ETH_RMII_PPS_OUT				CAN2_RX_1
PB6		TIM8_CH1_1	TIM4_CH1	USART1_TX_1	USBFS_DM USBHS_DM		I2C1_SCL				DVP_D5		CAN2_TX_1
PB7		TIM8_CH2_1	TIM4_CH2	USART1_RX_1	USBFS_DP USBHS_DP		I2C1_SDA			FSMC_NADV			
PB8		TIM8_CH3_1 TIM10_CH1	TIM4_CH3	UART6_TX_1			I2C1_SCL_1		ETH_MII_TXD3	SDIO_D4	DVP_D6		CAN1_RX_2
PB9		TIM8_BKIN_1 TIM10_CH2	TIM4_CH4	UART6_RX_1			I2C1_SDA_1			SDIO_D5	DVP_D7		CAN1_TX_2
PB10		TIM10_BKIN_1	TIM2_CH3_2 TIM2_CH3_3	USART3_TX			I2C2_SCL		ETH_MII_RX_ER			OPA2_CH0N	
PB11		TIM10_ETR_1	TIM2_CH4_2 TIM2_CH4_3	USART3_RX			I2C2_SDA		ETH_MII_TX_EN ETH_RMII_TX_EN			OPA1_CH0N	
PB12		TIM1_BKIN		USART3_CK			I2C2_SMBA	SPI2_NSS I2S2_WS	ETH_MII_TXD0 ETH_RMII_TXD0 ETH_RGMII_MDC			OPA4_CH0P	CAN2_RX
PB13		TIM1_CH1N		USART3_CTS USART3_CTS_1				SPI2_SCK I2S2_CK	ETH_MII_TXD1 ETH_RMII_TXD1 ETH_RGMII_MDIO			OPA3_CH0P	CAN2_TX
PB14		TIM1_CH2N		USART3_RTS USART3_RTS_1				SPI2_MISO		SDIO_D0		OPA2_CH0P	
PB15		TIM1_CH3N		USART1_TX_2				SPI2_MOSI I2S2_SD		SDIO_D1		OPA1_CH0P	
PC0	ADC_IN10	TIM9_CH1N		UART6_TX					ETH_RGMII_RXC				
PC1	ADC_IN11	TIM9_CH2N		UART6_RX					ETH_MII_MDC ETH_RMII_MDC ETH_RGMII_RXCTL				
PC2	ADC_IN12	TIM9_CH3N		UART7_TX					ETH_MII_TXD2 ETH_RGMII_RXD0			OPA3_CH1N	
PC3	ADC_IN13	TIM10_CH3		UART7_RX					ETH_MII_TX_CLK ETH_RGMII_RXD1			OPA4_CH1N	
PC4	ADC_IN14	TIM9_CH4		USART1_CTS_3 UART8_TX					ETH_MII_RXD0 ETH_RMII_RXD0 ETH_RGMII_TXD1			OPA4_CH1P	
PC5	ADC_IN15	TIM9_BKIN		USART1_RTS_3 UART8_RX					ETH_MII_RXD1 ETH_RMII_RXD1 ETH_RGMII_TXD2			OPA3_CH1P	
PC6		TIM8_CH1	TIM3_CH1_3					I2S2_MCK	ETH_RXP	SDIO_D6			
PC7		TIM8_CH2	TIM3_CH2_3					I2S3_MCK <sup>(2)</sup>	ETH_RXN	SDIO_D7			
PC8		TIM8_CH3	TIM3_CH3_3						ETH_TXP	SDIO_D0	DVP_D2		
PC9		TIM8_CH4	TIM3_CH4_3						ETH_TXN	SDIO_D1	DVP_D3		
PC10		TIM10_ETR		USART3_TX_1 UART4_TX				SPI3_SCK_1 I2S3_CK_1		SDIO_D2	DVP_D8		
PC11		TIM10_CH4		USART3_RX_1 UART4_RX				SPI3_MISO_1		SDIO_D3	DVP_D4		
PC12		TIM10_BKIN		USART3_CK_1 UART5_TX				SPI3_MOSI_1 I2S3_SD_1		SDIO_CK	DVP_D9		
PC13		TIM8_CH4_1				TAMPER-RTC							
PC14		TIM9_CH4_1				OSC32_IN							
PC15		TIM10_CH4_1				OSC32_OUT							
PD0		TIM10_ETR_2 TIM10_ETR_3				OSC_IN				FSMC_D2			CAN1_RX_3

Alternate Pin	ADC DAC	TIM1 8/9/10	TIM2 3/4/5	UART USART	USB	SYS	I2C	SPI I2S	ETH	FSMC SDIO	DVP	OPA	CAN
PD1		TIM10_CH1_2 TIM10_CH1_3				OSC_OUT				FSMC_D3			CAN1_TX_3
PD2			TIM3_ETR TIM3_ETR_2 TIM3_ETR_3	UART5_RX						SDIO_CMD FSMC_NADV	DVP_D11		
PD3		TIM10_CH2_2 TIM10_CH2_3		USART2_CTS_1						FSMC_CLK			
PD4				USART2_RTS_1						FSMC_NOE			
PD5		TIM10_CH3_2 TIM10_CH3_3		USART2_TX_1						FSMC_NWE			
PD6				USART2_RX_1						FSMC_NWAIT	DVP_D10		
PD7		TIM10_CH4_2 TIM10_CH4_3		USART2_CK_1						FSMC_NE1 FSMC_NCE2			
PD8		TIM9_CH1N_2 TIM9_CH1N_3		USART3_TX_3					ETH_MII_RX_DV_1 ETH_RMII_CRS_DV_1	FSMC_D13			
PD9		TIM9_CH1_2 TIM9_ETR_2 TIM9_CH1_3 TIM9_ETR_3		USART3_RX_3					ETH_MII_RXD0_1 ETH_RMII_RXD0_1	FSMC_D14			
PD10		TIM9_CH2N_2 TIM9_CH2N_3		USART3_CK_3 USART3_CK_2					ETH_MII_RXD1_1 ETH_RMII_RXD1_1	FSMC_D15			
PD11		TIM9_CH2_2 TIM9_CH2_3		USART3_CTS_3 USART3_CTS_2					ETH_MII_RXD2_1	FSMC_A16			
PD12		TIM9_CH3N_2 TIM9_CH3N_3	TIM4_CH1_1	USART3_RTS_3 USART3_RTS_2					ETH_MII_RXD3	FSMC_A17			
PD13		TIM9_CH3_2 TIM9_CH3_3	TIM4_CH2_1							FSMC_A18			
PD14		TIM9_BKIN_2 TIM9_BKIN_3	TIM4_CH3_1							FSMC_D0			
PD15		TIM9_CH4_2 TIM9_CH4_3	TIM4_CH4_1							FSMC_D1			
PE0			TIM4_ETR TIM4_ETR_1	UART4_TX_2 UART4_TX_3						FSMC_NBL0			
PE1				UART4_RX_2 UART4_RX_3						FSMC_NBL1			
PE2		TIM10_BKIN_2 TIM10_BKIN_3								FSMC_A23			
PE3		TIM10_CH1N_2 TIM10_CH1N_3								FSMC_A19			
PE4		TIM10_CH2N_2 TIM10_CH2N_3								FSMC_A20			
PE5		TIM10_CH3N_2 TIM10_CH3N_3								FSMC_A21			
PE6										FSMC_A22			
PE7		TIM1_ETR_3								FSMC_D4		OPA3_OUT1	
PE8		TIM1_CH1N_3		UART5_TX_2 UART5_TX_3						FSMC_D5		OPA4_OUT1	
PE9		TIM1_CH1_3		UART5_RX_2 UART5_RX_3						FSMC_D6			
PE10		TIM1_CH2N_3		UART6_TX_2 UART6_TX_3						FSMC_D7			
PE11		TIM1_CH2_3		UART6_RX_2 UART6_RX_3						FSMC_D8			
PE12		TIM1_CH3N_3		UART7_TX_2 UART7_TX_3						FSMC_D9			
PE13		TIM1_CH3_3		UART7_RX_2 UART7_RX_3						FSMC_D10			
PE14		TIM1_CH4_3		UART8_TX_2 UART8_TX_3						FSMC_D11		OPA2_OUT1	
PE15		TIM1_BKIN_3		UART8_RX_2 UART8_RX_3						FSMC_D12		OPA1_OUT1	

*Note 1: SPI3\_MOSI(I2S3\_SD) is mapped to PB5 by default. only for products with the penultimate digit of the lot number greater than 2. when using SPI3, the default mapping of SPI3\_MOSI(I2S3\_SD) is automatically changed to PA9 if both 10M Ethernet and I2S function of SPI3 are used.*

*Note 2: The default mapping of I2S3\_MCK is mapped to PC7. only for the products with the penultimate digit of the lot number greater than 2, if 10M Ethernet and I2S3 are used at the same time, the default mapping of I2S3\_MCK is automatically changed to PA8.*

## Chapter 4 Electrical Characteristics

### 4.1 Test Conditions

Unless otherwise specified and marked, all voltages are referenced to  $V_{SS}$ .

All minimum and maximum values are guaranteed in the worst conditions of ambient temperature, supply voltage and clock frequency. Typical values are based on normal temperature (25°C) and  $V_{DD} = 3.3V$  environment, which are given only as design guidelines.

The data based on comprehensive evaluation, design simulation or technology characteristics are not tested in production. On the basis of comprehensive evaluation, the minimum and maximum values refer to sample tests. Unless otherwise specified that is tested, the characteristic parameters are guaranteed by comprehensive evaluation or design.

Power supply scheme:

Figure 4-1 Typical circuit for conventional power supply

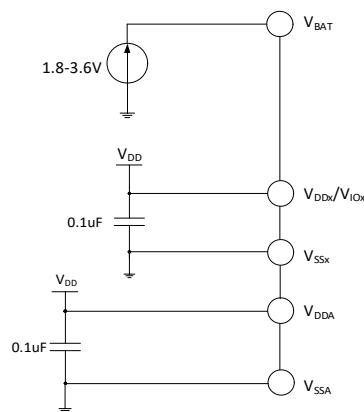

### 4.2 Absolute Maximum Ratings

Stresses at or above the absolute maximum ratings listed in the table below may cause permanent damage to the device.

Table 4-1 Absolute maximum ratings

Symbol	Description	Min.	Max.	Unit
$T_A$	Ambient temperature during operation	-40	85	°C
$T_S$	Ambient temperature during storage	-40	125	°C
$V_{DD}-V_{SS}$	External main supply voltage (including $V_{DDA}$ and $V_{DD}$ )	-0.3	4.0	V
$V_{I/O}-V_{SS}$	I/O domain supply voltage	-0.3	4.0	V
$V_{IN}$	Input voltage on the FT (5V tolerance) pin	$V_{SS}-0.3$	5.5	V
	Input voltage on other pins	$V_{SS}-0.3$	$V_{DD}+0.3$	
$ \Delta V_{DD\_x} $	Variations between different main power supply pins		50	mV
$ \Delta V_{I/O\_x} $	Variations between different I/O power supply pins		50	mV
$ \Delta V_{SS\_x} $	Variations between different ground pins		50	mV
$V_{ESD(HBM)}$	Electrostatic discharge voltage (human body model, non-contact)	4K		V



	USB pins (PA11, PA12)	3K		V
$I_{VDD}$	Total current into $V_{DD}/V_{DDA}/V_{IO}$ power lines (source)		150	mA
$I_{VSS}$	Total current out of $V_{SS}$ ground lines (sink)		150	
$I_{I/O}$	Sink current on any I/O and control pin		25	
	Output current on any I/O and control pin		-25	
$I_{INJ(PIN)}$	Injected current on NRST pin		+/-5	
	Injected current on HSE's OSC_IN pin and LSE's OSC_IN pin		+/-5	
	Injected current on other pins		+/-5	
$\sum I_{INJ(PIN)}$	Total injected current on all I/Os and control pins		+/-25	

## 4.3 Electrical Characteristics

### 4.3.1 Operating Conditions

Table 4-2 General operating conditions

Symbol	Parameter	Condition	Min.	Max.	Unit
$F_{HCLK}$	Internal AHB clock frequency			144	MHz
$F_{PCLK1}$	Internal APB1 clock frequency			144	MHz
$F_{PCLK2}$	Internal APB2 clock frequency			144	MHz
$V_{DD}$	Standard operating voltage		2.4	3.6	V
		Use USB or ETH	3.0	3.6	
$V_{IO}$	Output voltage on most I/O pins	$V_{IO}$ cannot be more than $V_{DD}$	2.4	3.6	V
$V_{DDA}$	Analog operating voltage (ADC is not used)	$V_{DDA}$ must be the same as $V_{IO}$ , $V_{REF+}$ cannot be higher than $V_{DDA}$ , $V_{REF-}$ is equal to $V_{SS}$ .	2.4	3.6	V
	Analog operating voltage (ADC is used)				
$V_{BAT}^{(1)}$	Backup operating voltage	Cannot be more than $V_{DD}$	1.8	3.6	V
$T_A$	Ambient temperature		-40	85	°C
$T_J$	Junction temperature range		-40	105	°C

Note: 1. The connection line from the battery to  $V_{BAT}$  should be as short as possible.

Table 4-3 Power-on and power-down conditions

Symbol	Parameter	Condition	Min.	Max.	Unit
$t_{VDD}$	$V_{DD}$ rise time rate		0	$\infty$	us/V
	$V_{DD}$ fall time rate		30	$\infty$	

### 4.3.2 Built-in Reset and Power Control Block Characteristics

Table 4-4 Reset and voltage monitor (For PDR, select high threshold gear)

Symbol	Parameter	Condition	Min.	Typ.	Max.	Unit
$V_{PVD}^{(1)}$	Level selection of programmable voltage detector	PLS[2:0] = 000 (rising edge)		2.39		V
		PLS[2:0] = 000 (falling edge)		2.31		V
		PLS[2:0] = 001 (rising edge)		2.56		V

		PLS[2:0] = 001 (falling edge)		2.48		V
		PLS[2:0] = 010 (rising edge)		2.65		V
		PLS[2:0] = 010 (falling edge)		2.57		V
		PLS[2:0] = 011 (rising edge)		2.78		V
		PLS[2:0] = 011 (falling edge)		2.69		V
		PLS[2:0] = 100 (rising edge)		2.89		V
		PLS[2:0] = 100 (falling edge)		2.81		V
		PLS[2:0] = 101 (rising edge)		3.05		V
		PLS[2:0] = 101 (falling edge)		2.96		V
		PLS[2:0] = 110 (rising edge)		3.17		V
		PLS[2:0] = 110 (falling edge)		3.08		V
		PLS[2:0] = 111 (rising edge)		3.31		V
		PLS[2:0] = 111 (falling edge)		3.21		V
$V_{PVDhyst}$	PVD hysteresis			0.08		V
$V_{POR/PDR}$	Power-on/power-down reset threshold	Rising edge	1.9	2.2	2.4	V
		Falling edge	1.9	2.2	2.4	V
$V_{PDRhyst}$	PDR hysteresis			20		mV
$t_{RSTTEMPO}$	Power on reset		24	28	30	mS
	Other resets		8	10	30	

Note: 1. Normal temperature test value.

### 4.3.3 Built-in Reference Voltage

Table 4-5 Embedded reference voltage

Symbol	Parameter	Condition	Min.	Typ.	Max.	Unit
$V_{REFINT}$	Internal reference voltage	$T_A = -40^{\circ}\text{C}\sim 85^{\circ}\text{C}$	1.17	1.2	1.23	V
$T_{S\_vrefint}$	ADC sampling time when reading the internal reference voltage				17.1	us

### 4.3.4 Supply Current Characteristics

Current consumption is a comprehensive index of a variety of parameters and factors. These parameters and factors include operating voltage, ambient temperature, I/O pin load, the software configuration of the product, the operating frequency, flip rate of the I/O pin, the location of the program in memory and the executed code, etc. The current consumption measurement method is as follows:

Figure 4-2 Current consumption measurement

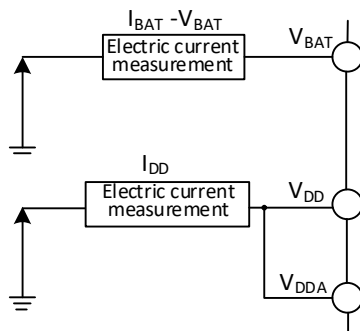

The microcontroller is in the following conditions:

Under normal temperature conditions and when  $V_{DD} = 3.3V$ , all I/O ports are configured with pull-down inputs, only one of HSE and HIS is enabled,  $HSE=8M$ ,  $HIS=8M$  (calibrated),  $F_{PLCK1}=F_{HCLK}/2$ ,  $F_{PLCK2}=F_{HCLK}$ , PLL is enabled when  $F_{HCLK}>8MHz$ . Enable or disable the power consumption of all peripheral clocks.

Table 4-6 Typical current consumption in Run mode, the data processing code runs from the internal Flash

Symbol	Parameter	Condition	Typ.		Unit	
			All peripherals enabled	All peripherals disabled <sup>(2)</sup>		
$I_{DD}^{(1)}$	Supply current in Run mode	External clock	$F_{HCLK} = 144MHz$	22.4	12.4	mA
			$F_{HCLK} = 72MHz$	11.5	6.5	
			$F_{HCLK} = 48MHz$	8.0	4.6	
			$F_{HCLK} = 36MHz$	6.4	3.8	
			$F_{HCLK} = 24MHz$	4.4	2.7	
			$F_{HCLK} = 16MHz$	3.5	2.3	
			$F_{HCLK} = 8MHz$	1.8	1.3	
			$F_{HCLK} = 4MHz$	1.3	1.0	
		Runs on the high-speed internal RC oscillator (HSI). Uses AHB prescaler to reduce the frequency.	$F_{HCLK} = 144MHz$	22.1	12.2	
			$F_{HCLK} = 72MHz$	11.3	6.3	
			$F_{HCLK} = 48MHz$	7.7	4.3	
			$F_{HCLK} = 36MHz$	5.8	3.3	
			$F_{HCLK} = 24MHz$	4.1	2.4	
			$F_{HCLK} = 16MHz$	3.0	1.8	
			$F_{HCLK} = 8MHz$	1.5	1.0	
			$F_{HCLK} = 4MHz$	1.0	0.7	
	$F_{HCLK} = 500KHz$	0.4	0.4			

Note: The above are measured parameters.

Table 4-7 Typical current consumption in Sleep mode, data processing code runs from internal Flash or SRAM

Symbol	Parameter	Condition	Typ.		Unit	
			All peripherals enabled	All peripherals disabled <sup>(2)</sup>		
$I_{DD}^{(1)}$	Supply current in Sleep mode (In this case, peripheral	External clock	$F_{HCLK} = 144MHz$	13.7	3.8	mA
			$F_{HCLK} = 72MHz$	7.2	2.3	
			$F_{HCLK} = 48MHz$	5.1	1.8	
			$F_{HCLK} = 36MHz$	4.0	1.5	
			$F_{HCLK} = 24MHz$	2.9	1.3	
			$F_{HCLK} = 16MHz$	2.2	1.1	
			$F_{HCLK} = 8MHz$	1.4	0.8	

power supply and clock are maintained)	Runs on the high-speed internal RC oscillator (HSI). Uses AHB prescaler to reduce the frequency.	$F_{HCLK} = 4\text{MHz}$	1.0	0.8
		$F_{HCLK} = 500\text{KHz}$	0.7	0.7
		$F_{HCLK} = 144\text{MHz}$	13.4	3.5
		$F_{HCLK} = 72\text{MHz}$	6.9	1.9
		$F_{HCLK} = 48\text{MHz}$	4.7	1.4
		$F_{HCLK} = 36\text{MHz}$	3.6	1.2
		$F_{HCLK} = 24\text{MHz}$	2.6	0.9
		$F_{HCLK} = 16\text{MHz}$	1.9	0.7
		$F_{HCLK} = 8\text{MHz}$	1.0	0.5
		$F_{HCLK} = 4\text{MHz}$	0.7	0.4
		$F_{HCLK} = 500\text{KHz}$	0.4	0.3

Note: The above are measured parameters.

Table 4-8 Typical current consumption in Stop and Standby mode

Symbol	Parameter	Condition	Typ.	Unit
$I_{DD}$	Supply current in Stop mode	Voltage regulator in Run mode, low-speed and high-speed internal RC oscillators and external oscillators off (no independent watchdog)	110	uA
		Voltage regulator in low-power mode, low-speed and high-speed internal RC oscillators and external oscillators off (no independent watchdog, PVD off), RAM enters low-power mode	30	
	Supply current in Standby mode	Low-speed internal RC oscillator and independent watchdog on, all RAM not powered	1.8	
		Low-speed internal RC oscillator on, independent watchdog off, all RAM not powered	1.8	
		LSI/LSE/RTC/IWDG off, 32K_RAM powered and in low-power mode	2.5	
		LSI/LSE/RTC/IWDG off, 2K_RAM powered and in low-power mode	1.2	
	LSI/LSE/RTC/IWDG off, all RAM not powered	1		
$I_{DD\_VBAT}$	Backup domain supply current (Remove $V_{DD}$ and $V_{DDA}$ , only powered by $V_{BAT}$ )	Low-speed external oscillator and RTC on	1.8	

Note: The above are measured parameters.

### 4.3.5 External Clock Source Characteristics

Table 4-9 From external high-speed clock

Symbol	Parameter	Condition	Min.	Typ.	Max.	Unit
$F_{HSE\_ext}$	External clock frequency		3	8	25	MHz
$V_{HSEH}^{(1)}$	OSC_IN input pin high level voltage		$0.8V_{I/O}$		$V_{I/O}$	V
$V_{HSEL}^{(1)}$	OSC_IN input pin low-level voltage		0		$0.2V_{I/O}$	V
$C_{in(HSE)}$	OSC_IN input capacitance			5		pF
Duty <sub>(HSE)</sub>	Duty cycle			50		%
$I_L$	OSC_IN input leakage current				$\pm 1$	$\mu A$

Note: 1. Failure to meet this condition may cause level recognition error.

Figure 4-3 External high-frequency clock source circuit

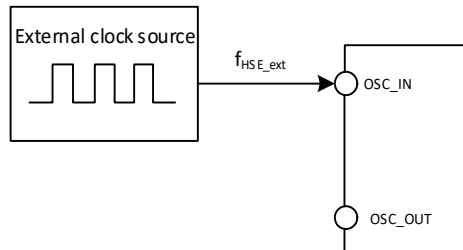

Table 4-10 From external low-speed clock

Symbol	Parameter	Condition	Min.	Typ.	Max.	Unit
$F_{LSE\_ext}$	User external clock frequency			32.768	1000	KHz
$V_{LSEH}$	OSC32_IN input pin high level voltage		$0.8V_{DD}$		$V_{DD}$	V
$V_{LSEL}$	OSC32_IN input pin low voltage		0		$0.2V_{DD}$	V
$C_{in(LSE)}$	OSC32_IN input capacitance			5		pF
Duty <sub>(LSE)</sub>	Duty cycle			50		%
$I_L$	OSC32_IN input leakage current				$\pm 1$	$\mu A$

Figure 4-4 External low-frequency clock source circuit

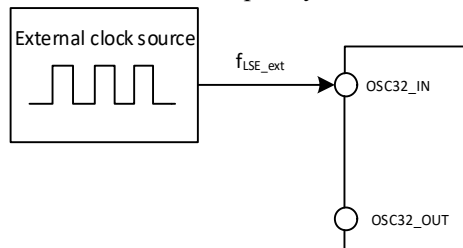

Table 4-11 High-speed external clock generated from a crystal/ceramic resonator

Symbol	Parameter	Condition	Min.	Typ.	Max.	Unit
$F_{OSC\_IN}$	Resonator frequency		3	8	25	MHz
$R_F$	Feedback resistance			250		k $\Omega$
$C$	Recommended load capacitance and corresponding crystal series impedance $R_S$	$R_S=60\Omega^{(1)}$		30		pF
$I_2$	HSE drive current	$V_{DD} = 3.3V$ , 20p load		0.53		mA
$g_m$	Oscillator transconductance	Startup		17		mA/V
$t_{SU(HSE)}$	Startup time	$V_{DD}$ is stable, 8M crystal		1.5	4	ms

Note 1: It is recommended that the ESR of 25M crystal should not exceed 60  $\Omega$ , and it can be relaxed if it is lower than 25M.

Circuit reference design and requirements:

The load capacitance of the crystal is subject to the recommendation of the crystal manufacturer,  $C_{L1}=C_{L2}$ .

Figure 4-5 Typical circuit of external 8M crystal

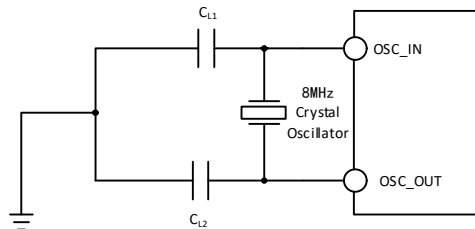

Table 4-12 Low-speed external clock generated by generated from a crystal/ceramic resonator (fLSE=32.768KHz)

Symbol	Parameter	Condition	Min.	Typ.	Max.	Unit
$R_F$	Feedback resistance			5		M $\Omega$
$C$	Recommended load capacitance and corresponding crystal serial impedance $R_S$	$R_S<70k\Omega$			15	pF
$i_2$	LSE drive current	$V_{DD} = 3.3V$		0.35		$\mu A$
$g_m$	Oscillator transconductance	Startup		25.3		$\mu A/V$
$t_{SU(LSE)}$	Startup time	$V_{DD}$ is stable		800		mS

Circuit reference design and requirements:

The load capacitance of the crystal is subject to the recommendation of the crystal manufacturer,  $C_{L1}=C_{L2}$ , generally 12pF is recommended.

Figure 4-6 Typical circuit of external 32.768K crystal

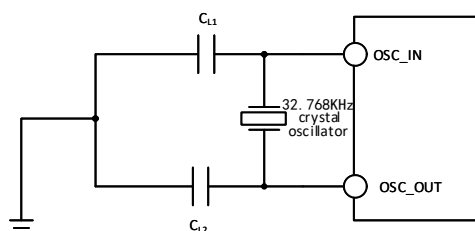

Note: The load capacitance  $C_L$  is calculated by the following formula:  $C_L = C_{L1} \times C_{L2} / (C_{L1} + C_{L2}) + C_{stray}$ .  $C_{stray}$  is the capacitance of the pin and the PCB board or PCB-related capacitance. Its typical value is between 2pF and 7pF.

### 4.3.6 Internal Clock Source Characteristics

Table 4-13 Internal high-speed (HSI) RC oscillator characteristics

Symbol	Parameter	Condition	Min.	Typ.	Max.	Unit
$F_{HSI}$	Frequency (after calibration)			8		MHz
$Duty_{HSI}$	Duty cycle		45	50	55	%
$ACC_{HSI}$	Accuracy of HSI oscillator (after calibration)	TA = 0°C~70°C	-1.8		1.8	%
		TA = -40°C~85°C	-3.0		2.5	%
$t_{SU(HSI)}$	HSI oscillator startup stabilization time				8	us
$I_{DD(HSI)}$	HSI oscillator power consumption		120	180	270	uA

Note: 1. Set register `RCC_CTLR HSION 1`, waiting for `HSIRDY` to set 1.

Table 4-14 Internal low-speed (LSI) RC oscillator characteristics

Symbol	Parameter	Condition	Min.	Typ.	Max.	Unit
$F_{LSI}$	Frequency		25	39	60	KHz
$Duty_{LSI}$	Duty cycle		45	50	55	%
$t_{SU(LSI)}$	LSI oscillator startup stabilization time	LSE on		230		us
		LSE off		5		ms
$I_{DD(LSI)}$	LSI oscillator power consumption			0.6		uA

### 4.3.7 PLL Characteristics

Table 4-15 PLL characteristics

Symbol	Parameter	Condition	Min.	Typ.	Max.	Unit
$F_{PLL\_IN}$	PLL input clock		3	8	25	MHz
	PLL input clock duty cycle		40		60	%
$F_{PLL\_OUT}$	PLL multiplier output clock		18		144 <sup>(1)</sup>	MHz
$t_{LOCK}$	PLL lock time			80	200	us

Note 1: The frequency multiplier must be selected to meet the PLL output frequency range.

Table 4-16 PLL2 and PLL3 characteristics

Symbol	Parameter	Condition	Min.	Typ.	Max.	Unit
$F_{PLL\_IN}$	PLL input clock		3		25	MHz
	PLL input clock duty cycle1		40		60	%
$F_{PLL\_OUT}$	PLL multiplier output clock		30		75 <sup>(1)</sup>	MHz
$F_{VCO}$	VCO output clock		60		150	MHz
$t_{LOCK1}$	PLL lock time			80	200	us

Note 1: The frequency multiplier must be selected to meet the PLL output frequency range.

### 4.3.8 Wakeup Time from Low-power Mode

Table 4-17 Wakeup time from low-power mode<sup>(1)</sup>

Symbol	Parameter	Condition	Typ.	Unit
$t_{wusleep}$	Wakeup from Sleep mode	Wake up using HSI RC clock	2.4	us
$t_{wustop}$	Wakeup from Stop mode (voltage regulator is in Run mode)	Wake on HSI RC clock	23.1	us
	Wakeup from Stop mode (voltage regulator is in low-power mode)	Voltage regulator wake-up time from low-power mode + HSI RC clock wake up	76.7	us
$t_{WUSTDBY}$	Wakeup from Standby mode	LDO stabilization time + HSI RC clock wake up + code load time <sup>(2)</sup> (take 256K as example)	8.9	ms

Note: 1. The above parameters are measured parameters.

2. The code load time is calculated based on the current zero-wait area capacity configured by the chip and the size of the loading configuration clock.

### 4.3.9 Memory Characteristics

Table 4-18 Flash memory characteristics

Symbol	Parameter	Condition	Min.	Typ.	Max.	Unit
$F_{prog}$	Programming frequency <sup>(1)</sup>	$T_A = -40^{\circ}\text{C} \sim 85^{\circ}\text{C}$			60	MHz
$t_{prog\_page}$	Page (256 bytes) programming time	$T_A = -40^{\circ}\text{C} \sim 85^{\circ}\text{C}$		2	2.5	ms
$t_{erase\_page}$	Page (256 bytes) erase time	$T_A = -40^{\circ}\text{C} \sim 85^{\circ}\text{C}$		16	20	ms
$t_{erase\_sec}$	Sector (4K bytes) erase time	$T_A = -40^{\circ}\text{C} \sim 85^{\circ}\text{C}$		16	20	ms
$V_{prog}$	Programming voltage		2.4		3.6	V

Note: 1. For the programming frequency of flash, read operation, program operation and erase operation are included. The clock is from HCLK.

Table 4-19 Flash memory endurance and data retention

Symbol	Parameter	Condition	Min.	Typ.	Max.	Unit
$N_{END}$	Endurance	$T_A = 25^{\circ}\text{C}$	10K	80K <sup>(1)</sup>		times
$t_{RET}$	Data retention		20			year

Note: The endurance parameter is actual measured, which is not guaranteed.

### 4.3.10 I/O Port Characteristics

Table 4-20 General-purpose I/O static characteristics

Symbol	Parameter	Condition	Min.	Typ.	Max.	Unit
$V_{IH}$	Standard I/O pin, input high-level voltage		$0.41*(V_{DD}-1.8)+1.3$		$V_{DD}+0.3$	V
	FT I/O pin, input high level voltage		$0.42*(V_{DD}-1.8)+1$		5.5	V
$V_{IL}$	Standard I/O pin, input low-level		-0.3		$0.28*(V_{DD}-$	V



	voltage				1.8)+0.6	
	FT I/O pin, input low-level voltage		-0.3		0.32*(V <sub>DD</sub> -1.8)+0.55	V
V <sub>hys</sub>	Standard I/O pin Schmitt trigger voltage hysteresis		150			mV
	FT I/O pin Schmitt trigger voltage hysteresis		90			
I <sub>lkg</sub>	Input leakage current	Standard I/O port			1	uA
		FT I/O port			3	
R <sub>PU</sub>	Weak pull-up equivalent resistance		30	40	50	kΩ
R <sub>PD</sub>	Weak pull-down equivalent resistance		30	40	50	kΩ
C <sub>I/O</sub>	I/O pin capacitance			5		pF

#### Output drive current characteristics

GPIO (General-Purpose Input/Output Port) can sink or output up to ±8mA current, and sink or output ±20mA current (not strictly to V<sub>OL</sub>/V<sub>OH</sub>). In user applications, the total driving current of all I/O pins cannot exceed the absolute maximum ratings given in Section 4.2:

Table 4-21 Output voltage characteristics

Symbol	Parameter	Condition	Min.	Max.	Unit
V <sub>OL</sub>	Output low level when 8 pins are sunk	TTL port, I <sub>IO</sub> = +8mA		0.4	V
V <sub>OH</sub>	Output high level when 8 pins are sourced	2.7V < V <sub>DD</sub> < 3.6V	V <sub>DD</sub> -0.4		
V <sub>OL</sub>	Output low level when 8 pins are sunk	CMOS port, I <sub>IO</sub> = +8mA		0.4	V
V <sub>OH</sub>	Output high level when 8 pins are sourced	2.7V < V <sub>DD</sub> < 3.6V	V <sub>DD</sub> -0.4		
V <sub>OL</sub>	Output low level when 8 pins are sunk	I <sub>IO</sub> = +20mA		1.0	V
V <sub>OH</sub>	Output high level when 8 pins are sourced	2.7V < V <sub>DD</sub> < 3.6V	V <sub>DD</sub> -1.2		
V <sub>OL</sub>	Output low level when 8 pins are sunk	I <sub>IO</sub> = +6mA		0.4	V
V <sub>OH</sub>	Output high level when 8 pins are sourced	2.4V < V <sub>DD</sub> < 2.7V	V <sub>DD</sub> -0.6		

Note: In the above conditions, if multiple IO pins are driven at the same time, the total current cannot exceed the absolute maximum ratings given in Table 4.2. In addition, when multiple I/O pins are driven at the same time, the current on the power/ground point is very large, which will cause the voltage drop to make the internal I/O voltage not reach the power supply voltage in the table, resulting in the drive current being less than the nominal value.

Table 4-22 Input/output AC characteristics

MODEx[1:0] configuration	Symbol	Parameter	Condition	Min.	Max.	Unit
10 (2MHz)	F <sub>max(IO)out</sub>	Maximum frequency	CL=50pF, V <sub>DD</sub> =2.7-3.6V		2	MHz
	t <sub>f(IO)out</sub>	Output high to low fall time	CL=50pF, V <sub>DD</sub> =2.7-3.6V		125	ns
	t <sub>r(IO)out</sub>	Output low to high rise time			125	ns
01 (10MHz)	F <sub>max(IO)out</sub>	Maximum frequency	CL=50pF, V <sub>DD</sub> =2.7-3.6V		10	MHz
	t <sub>f(IO)out</sub>	Output high to low fall time	CL=50pF, V <sub>DD</sub> =2.7-3.6V		25	ns
	t <sub>r(IO)out</sub>	Output low to high rise time			25	ns

11 (50MHz)	$F_{\max(\text{IO})\text{out}}$	Maximum frequency	$CL=30\text{pF}, V_{\text{DD}}=2.7\text{-}3.6\text{V}$	50	MHz
			$CL=50\text{pF}, V_{\text{DD}}=2.7\text{-}3.6\text{V}$	30	MHz
	$t_{\text{f}(\text{IO})\text{out}}$	Output high to low fall time	$CL=30\text{pF}, V_{\text{DD}}=2.7\text{-}3.6\text{V}$	20	ns
			$CL=50\text{pF}, V_{\text{DD}}=2.7\text{-}3.6\text{V}$	5	ns
	$t_{\text{r}(\text{IO})\text{out}}$	Output low to high rise time	$CL=30\text{pF}, V_{\text{DD}}=2.7\text{-}3.6\text{V}$	8	ns
			$CL=50\text{pF}, V_{\text{DD}}=2.7\text{-}3.6\text{V}$	12	ns
	$t_{\text{EXTI}\text{pw}}$	The EXTI controller detects the pulse width of the external signal		10	ns

### 4.3.11 NRST Pin Characteristics

Table 4-23 External reset pin characteristics

Symbol	Parameter	Condition	Min.	Typ.	Max.	Unit
$V_{\text{IL}(\text{NRST})}$	NRST input low-level voltage		-0.3		$0.28*(V_{\text{DD}}-1.8)+0.6$	V
$V_{\text{IH}(\text{NRST})}$	NRST input high-level voltage		$0.41*(V_{\text{DD}}-1.8)+1.3$		$V_{\text{DD}}+0.3$	V
$V_{\text{hys}(\text{NRST})}$	NRST Schmitt Trigger voltage hysteresis		150			mV
$R_{\text{PU}}^{(1)}$	Weak pull-up equivalent resistance		30	40	50	k $\Omega$
$V_{\text{F}(\text{NRST})}$	NRST input filtered pulse width				100	ns
$V_{\text{NF}(\text{NRST})}$	NRST input not filtered pulse width		300			ns

Note: 1. The pull-up resistor is a real resistor in series with a switchable PMOS implementation. The resistance of this PMOS/NMOS switch is very small (approximately 10%).

Circuit reference design and requirements:

Figure 4-7 Typical circuit of external reset pin

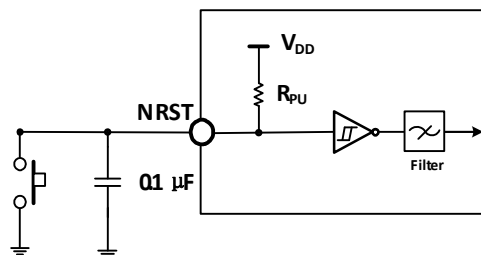

### 4.3.12 TIM Timer Characteristics

Table 4-24 TIMx characteristics

Symbol	Parameter	Condition	Min.	Max.	Unit
$t_{\text{res}(\text{TIM})}$	Timer reference clock		1		$t_{\text{TIMxCLK}}$
		$f_{\text{TIMxCLK}} = 72\text{MHz}$	13.9		ns

$F_{EXT}$	Timer external clock frequency on CH1 to CH4		0	$f_{TIMxCLK}/2$	MHz
		$f_{TIMxCLK} = 72MHz$	0	36	MHz
$R_{esTIM}$	Timer resolution			16	bit
$t_{COUNTER}$	16-bit counter clock cycle when the internal clock is selected		1	65536	$t_{TIMxCLK}$
		$f_{TIMxCLK} = 72MHz$	0.0139	910	us
$t_{MAX\_COUNT}$	Maximum possible count			65535	$t_{TIMxCLK}$
		$f_{TIMxCLK} = 72MHz$		59.6	s

### 4.3.13 I2C Interface Characteristics

Figure 4-8 I2C bus timing diagram

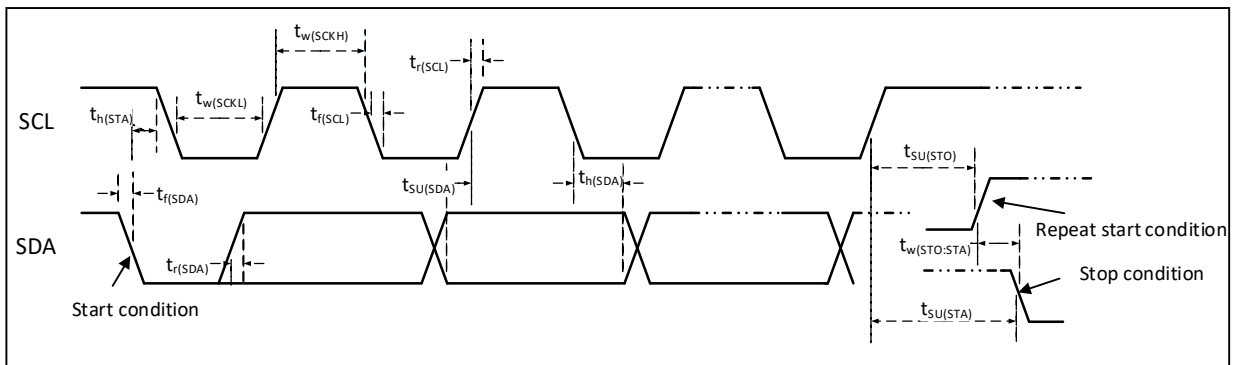

Table 4-25 I2C interface characteristics

Symbol	Parameter	Standard I2C		Fast I2C		Unit
		Min.	Max.	Min.	Max.	
$t_w(SCKL)$	SCL clock low time	4.7		1.2		us
$t_w(SCKH)$	SCL clock high time	4.0		0.6		us
$t_{SU}(SDA)$	SDA data setup time	250		100		ns
$t_h(SDA)$	SDA data hold time	0		0	900	ns
$t_r(SDA)/t_r(SCL)$	SDA and SCL rise time		1000	20		ns
$t_f(SDA)/t_f(SCL)$	SDA and SCL fall time		300			ns
$t_h(STA)$	Start condition hold time	4.0		0.6		us
$t_{SU}(STA)$	Repeated start condition setup time	4.7		0.6		us
$t_{SU}(STO)$	Stop condition setup time	4.0		0.6		us
$t_w(STO:STA)$	Time from stop condition to start condition (bus free)	4.7		1.2		us
$C_b$	Capacitive load for each bus		400		400	pF

### 4.3.14 SPI Interface Characteristics

Figure 4-9 SPI timing diagram in Master mode

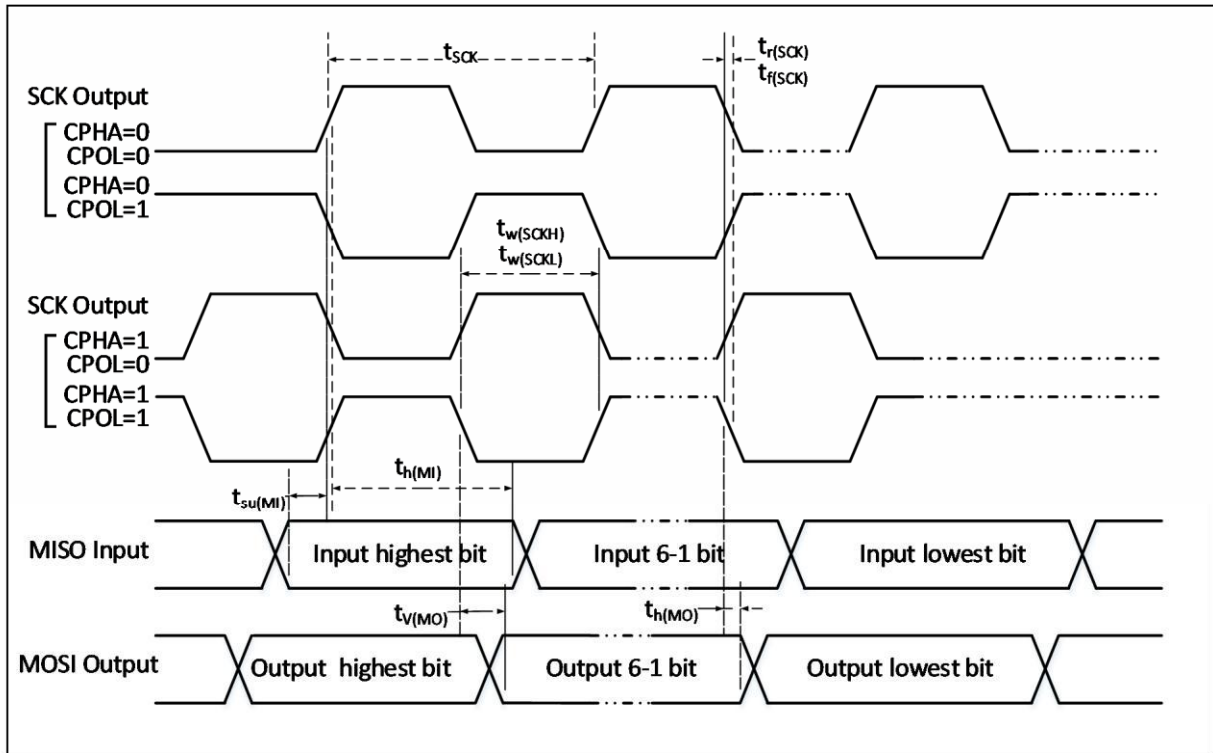

Figure 4-10 SPI timing diagram in Slave mode (CPHA=0)

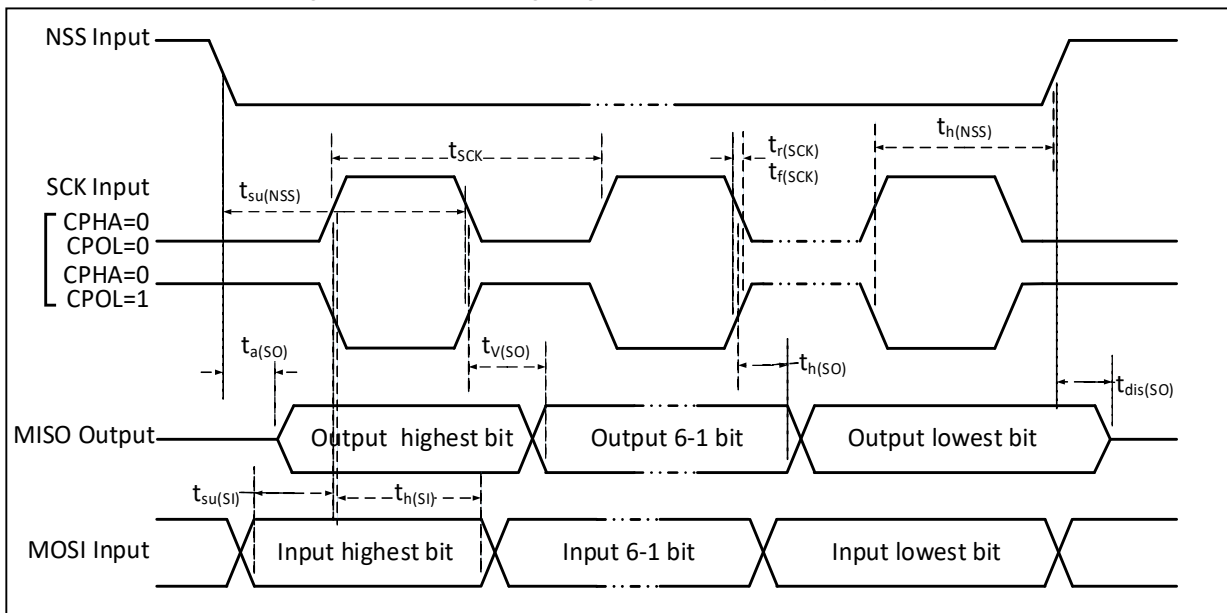

Figure 4-11 SPI timing diagram in Slave mode (CPHA=1)

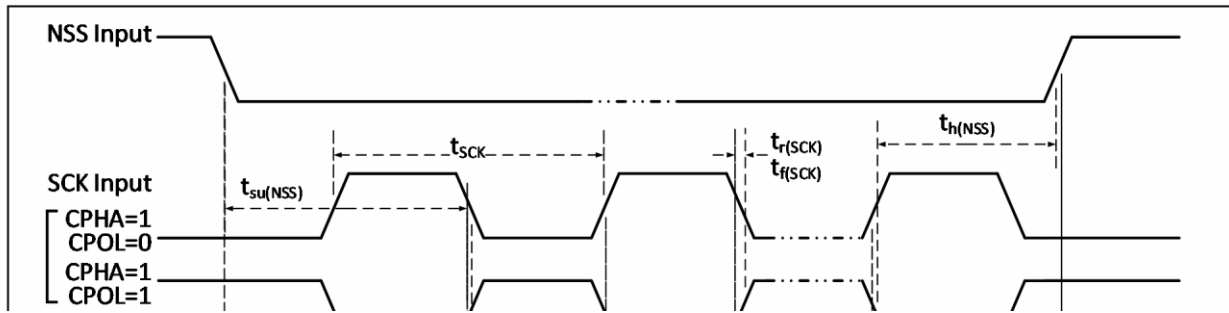

Table 4-26 SPI interface characteristics

Symbol	Parameter	Condition	Min.	Max.	Unit
$f_{SCK}/t_{SCK}$	SPI clock frequency	Master mode		36	MHz
		Slave mode		36	MHz
$t_{r(SCK)}/t_{f(SCK)}$	SPI clock rise and fall time	Load capacitance:C = 30pF		20	ns
$t_{su(NSS)}$	NSS setup time	Slave mode	$2t_{PCLK}$		ns
$t_{h(NSS)}$	NSS hold time	Slave mode	$2t_{PCLK}$		ns
$t_{w(SCKH)}/t_{w(SCKL)}$	SCK high and low time	Master mode, $f_{PCLK} = 36\text{MHz}$ , Prescaler factor = 4	40	60	ns
$t_{su(MI)}$	Data input setup time	Master mode	5		ns
$t_{su(SI)}$		Slave mode	5		ns
$t_{h(MI)}$	Data input hold time	Master mode	5		ns
$t_{h(SI)}$		Slave mode	4		ns
$t_{a(SO)}$	Data output access time	Slave mode, $f_{PCLK} = 20\text{MHz}$	0	$1t_{PCLK}$	ns
$t_{dis(SO)}$	Data output disable time	Slave mode	0	10	ns
$t_{v(SO)}$	Data output valid time	Slave mode (After enable edge)		25	ns
$t_{v(MO)}$		Master mode (After enable edge)		5	ns
$t_{h(SO)}$	Data output hold time	Slave mode (After enable edge)	15		ns
$t_{h(MO)}$		Master mode (After enable edge)	0		ns

### 4.3.15 I2S Interface Characteristics

Figure 4-12 I2S master timing diagram (Philips protocol)

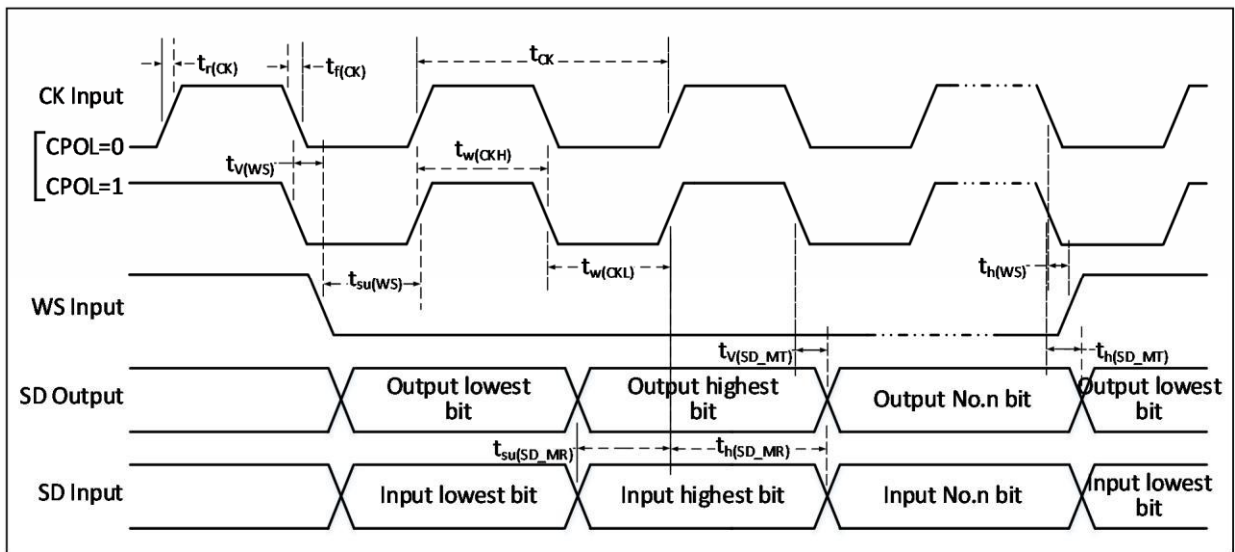

Figure 4-13 I2S slave timing diagram (Philips protocol)

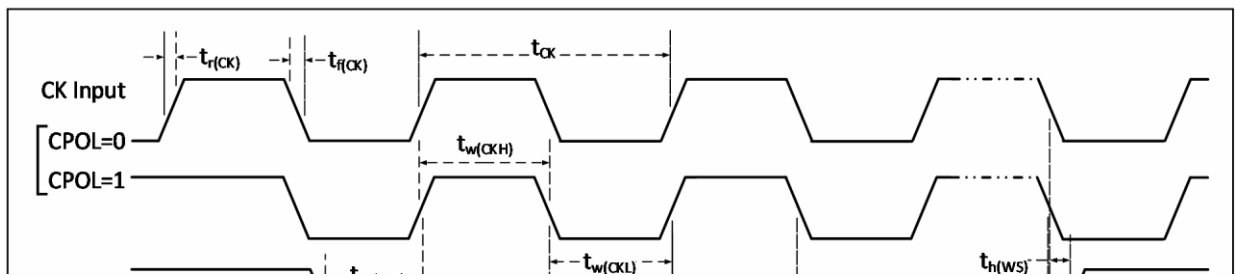

Table 4-27 I2S interface characteristics

Symbol	Parameter	Condition	Min.	Max.	Unit
$f_{CK}/t_{CK}$	I <sup>2</sup> S clock frequency	Master mode		8	MHz
		Slave mode		8	MHz
$t_{r(CK)}/t_{f(CK)}$	I <sup>2</sup> S clock rise and fall time	Load capacitance: C = 30pF		20	ns
$t_{v(WS)}$	WS valid time	Master mode		5	ns
$t_{su(WS)}$	WS setup time	Slave mode	10		ns
$t_{h(WS)}$	WS hold time	Master mode	0		ns
		Slave mode	0		ns
$t_{w(CKH)}/t_{w(CKL)}$	SCK high and low time	Master mode, $f_{PCLK} = 36\text{MHz}$ ,	40	60	%

		Prescaler factor =4			
$t_{SU(SD\_MR)}$	Data input setup time	Master mode	8		ns
$t_{SU(SD\_SR)}$		Slave mode	8		ns
$t_{h(SD\_MR)}$	Data input hold time	Master mode	5		ns
$t_{h(SD\_SR)}$		Slave mode	4		ns
$t_{h(SD\_MT)}$	Data output hold time	Master mode (After enable edge)		5	ns
$t_{h(SD\_ST)}$		Slave mode (After enable edge)		5	ns
$t_{V(SD\_MT)}$	Data output valid time	Master mode (After enable edge)		5	ns
$t_{V(SD\_ST)}$		Slave mode (After enable edge)		4	ns

### 4.3.16 USB Interface Characteristics

Table 4-28 USB characteristics

Symbol	Parameter	Condition	Min.	Max.	Unit
$V_{DD}$	USB operating voltage		3.0	3.6	V
$V_{SE}$	Single-ended receiver threshold	$V_{DD} = 3.3V$	1.2	1.9	V
$V_{OL}$	Static output low level			0.3	V
$V_{OH}$	Static output high level		2.8	3.6	V
$V_{HSSQ}$	High-speed suppression information detection threshold		100	150	mV
$V_{HSDSC}$	High-speed disconnection detection threshold		500	625	mV
$V_{HSOI}$	High-speed idle level		-10	10	mV
$V_{HSOH}$	High-speed data high level		360	440	mV
$V_{HSOL}$	High-speed data low level		-10	10	mV

### 4.3.17 SD/MMC Interface Characteristics

Figure 4-14 SD high-speed timing diagram

Figure 4-15 SD default timing diagram

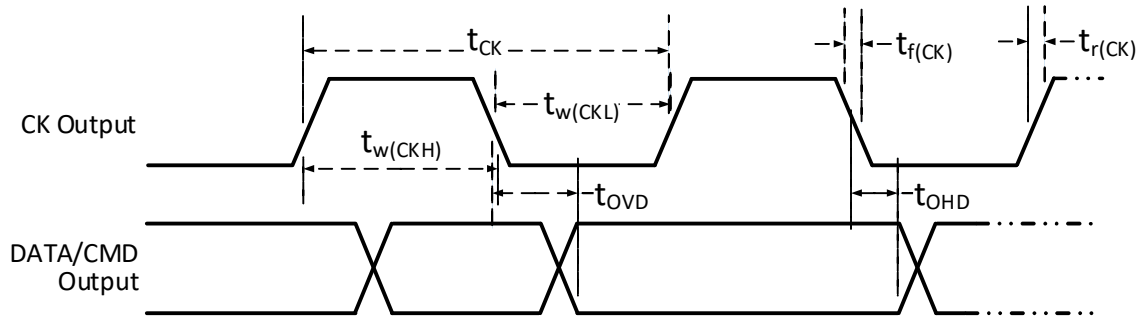

Table 4-29 SD/MMC interface characteristics

Symbol	Parameter	Condition	Min.	Max.	Unit
$f_{CK}/t_{CK}$	Clock frequency in data transfer mode	$CL \leq 30pF$		48	MHz
$t_{w(CKL)}$	Clock low time	$CL \leq 30pF$	6		ns
$t_{w(CKH)}$	Clock high time	$CL \leq 30pF$	6		
$t_{r(CK)}$	Rise Time	$CL \leq 30pF$		4	
$t_{f(CK)}$	Fall time	$CL \leq 30pF$		4	
CMD/DAT input (refer to CK)					
$t_{ISU}$	Input setup time	$CL \leq 30pF$	7		ns
$t_{IH}$	Input hold time	$CL \leq 30pF$	2		
CMD/DAT output in MMC and SD high-speed mode (refer to CK)					
$t_{OV}$	Output valid time	$CL \leq 30pF$		5	ns
$t_{OH}$	Output hold time	$CL \leq 30pF$	20		
CMD/DAT output in SD default mode (refer to CK)					
$t_{OVD}$	Output valid default time	$CL \leq 30pF$		8	ns
$t_{OHD}$	Output hold default time	$CL \leq 30pF$	20		



### 4.3.18 FSMC Characteristics

Figure 4-16 Asynchronous multiplexed PSRAM/NOR read waveform

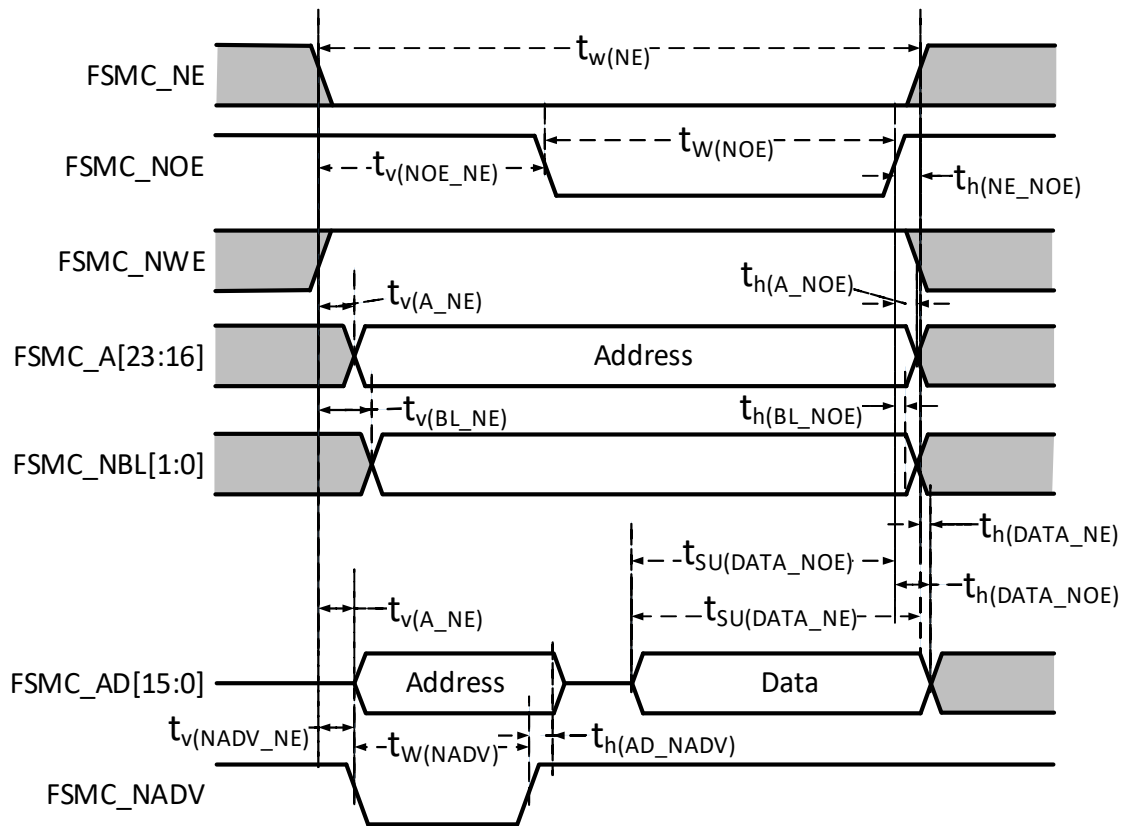

Table 4-30 Asynchronous multiplexed PSRAM/NOR read timings

Symbol	Parameter	Min.	Max.	Unit
$t_{w(NE)}$	FSMC_NE low time	$7t_{HCLK}$		ns
$t_{v(NOE\_NE)}$	FSMC_NE low to FSMC_NOE low	0		
$t_{w(NOE)}$	FSMC_NOE low time	$7t_{HCLK}$		
$t_{h(NE\_NOE)}$	FSMC_NOE high to FSMC_NE high hold time	0		
$t_{v(A\_NE)}$	FSMC_NE low to FSMC_A valid	0	5	
$t_{v(NADV\_NE)}$	FSMC_NE low to FSMC_NADV low	0	5	
$t_{w(NADV)}$	FSMC_NADV low time	$t_{HCLK}$		
$t_{h(AD\_NADV)}$	FSMC_AD (address) valid hold time after FSMC_NADV high	$2t_{HCLK}$		
$t_{h(A\_NOE)}$	Address hold time after FSMC_NOE high	0		
$t_{h(BL\_NOE)}$	FSMC_BL hold time after FSMC_NOE high	0		
$t_{v(BL\_NE)}$	FSMC_NE low to FSMC_BL valid	0	5	
$t_{sU(DATA\_NE)}$	Data to FSMC_NE high setup time	$3t_{HCLK}$		
$t_{sU(DATA\_NOE)}$	Data to FSMC_NOE high setup time	$3t_{HCLK}$		
$t_{h(DATA\_NE)}$	Data hold time after FSMC_NE high	0		
$t_{h(DATA\_NOE)}$	Data hold time after FSMC_NOE high	0		

Figure 4-17 Asynchronous multiplexed PARAM/NOR write waveform

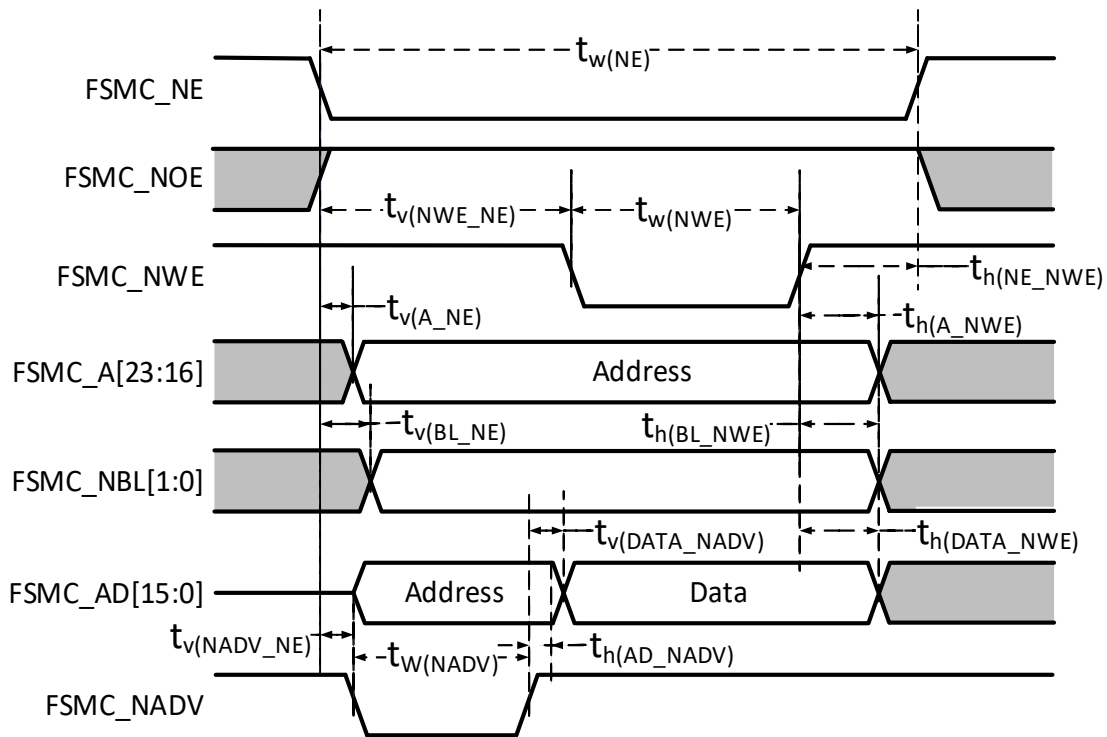

Table 4-31 Asynchronous multiplexed PARAM/NOR write timings

Symbol	Parameter	Min.	Max.	Unit
$t_{w(NE)}$	FSMC_NE low time	$5t_{HCLK}$		ns
$t_{v(NWE\_NE)}$	FSMC_NE low to FSMC_NWE low	$3t_{HCLK}$		
$t_{w(NWE)}$	FSMC_NWE low time	$2t_{HCLK}$		
$t_{h(NE\_NWE)}$	FSMC_NWE high to FSMC_NE high hold time	$t_{HCLK}$		
$t_{v(A\_NE)}$	FSMC_NE low to FSMC_A valid	0	5	
$t_{v(NADV\_NE)}$	FSMC_NE low to FSMC_NADV low	0	5	
$t_{w(NADV)}$	FSMC_NADV low time	$t_{HCLK}$		
$t_{h(AD\_NADV)}$	FSMC_AD (address) valid hold time after FSMC_NADV high	$2t_{HCLK}$		
$t_{h(A\_NWE)}$	Address hold time after FSMC_NWE high	$t_{HCLK}$		
$t_{v(BL\_NE)}$	FSMC_NE low to FSMC_BL valid	0	5	
$t_{h(BL\_NWE)}$	FSMC_BL hold time after FSMC_NWE high	$t_{HCLK}$		
$t_{v(DATA\_NADV)}$	FSMC_NADV high to data hold time	$2t_{HCLK}$		
$t_{h(DATA\_NWE)}$	Data hold time after FSMC_NWE high	$t_{HCLK}$		

Figure 4-18 Synchronous multiplexed NOR/PARAM read waveform

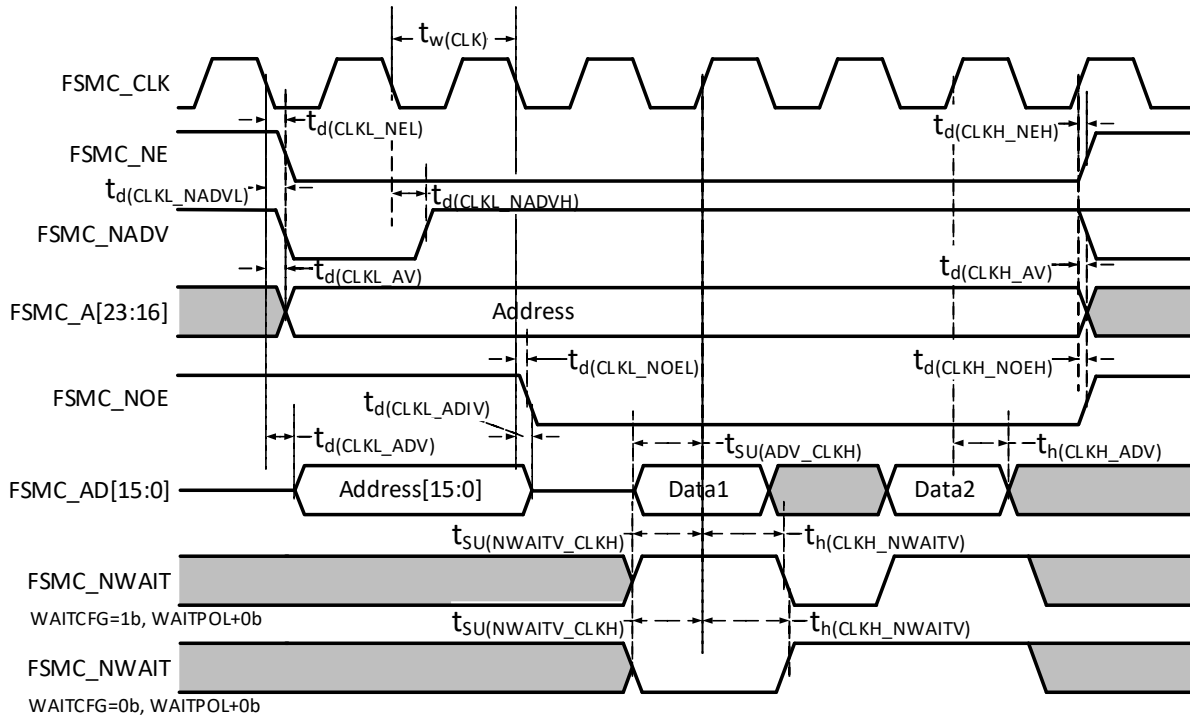

Table 4-32 Synchronous multiplexed NOR/PSRAM read timings

Symbol	Parameter	Min.	Max.	Unit
$t_{w(CLK)}$	FSMC_CLK period	$2t_{HCLK}$		ns
$t_{d(CLKL\_NEL)}$	FSMC_CLK low to FSMC_NE low	0	5	
$t_{d(CLKH\_NEH)}$	FSMC_CLK high to FSMC_NE high	$0.5t_{HCLK}$	$0.5t_{HCLK}$	
$t_{d(CLKL\_NADV)}$	FSMC_CLK low to FSMC_NADV low	0	5	
$t_{d(CLKL\_NADVH)}$	FSMC_CLK low to FSMC_NADV high	0	5	
$t_{d(CLKL\_AV)}$	FSMC_CLK low to FSMC_Ax valid (x = 16...23)	0	5	
$t_{d(CLKH\_AIV)}$	FSMC_CLK high to FSMC_Ax invalid (x = 16...23)	0	5	
$t_{d(CLKL\_NOEL)}$	FSMC_CLK low to FSMC_NOE low	$2t_{HCLK}$		
$t_{d(CLKH\_NOEH)}$	FSMC_CLK high to FSMC_NOE high	$t_{HCLK}$		
$t_{d(CLKL\_ADV)}$	FSMC_CLK low to FSMC_AD[15:0] valid	0	5	
$t_{d(CLKL\_ADIV)}$	FSMC_CLK low to FSMC_AD[15:0] invalid	0	5	
$t_{SU(ADV\_CLKH)}$	FSMC_AD[15:0] valid data before FSMC_CLK high	8		
$t_{h(CLKH\_ADV)}$	FSMC_AD[15:0] valid data after FSMC_CLK high	8		
$t_{SU(NWAITV\_CLKH)}$	FSMC_NWAIT valid before FSMC_CLK high	6		
$t_{h(CLKH\_NWAITV)}$	FSMC_NWAIT valid after FSMC_CLK high	2		

Figure 4-19 Synchronous multiplexed PSRAM write waveform

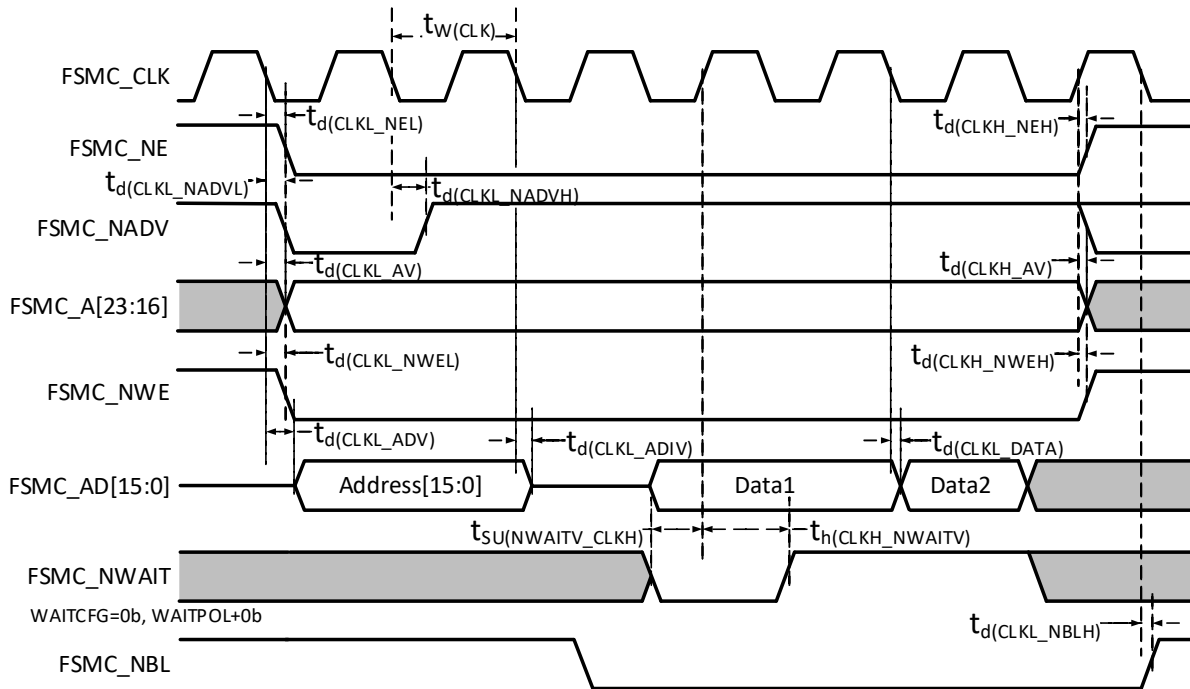

Table 4-33 Synchronous multiplexed PSRAM write timings

Symbol	Parameter	Min.	Max.	Unit
$t_{w(CLK)}$	FSMC_CLK period	$2t_{HCLK}$		ns
$t_{d(CLKL\_NEL)}$	FSMC_CLK low to FSMC_NE low	0	5	
$t_{d(CLKH\_NEH)}$	FSMC_CLK high to FSMC_NE high	$0.5t_{HCLK}$	$0.5t_{HCLK}$	
$t_{d(CLKL\_NADV)}$	FSMC_CLK low to FSMC_NADV low	0	5	
$t_{d(CLKL\_NADVH)}$	FSMC_CLK low to FSMC_NADV high	0	5	
$t_{d(CLKL\_AV)}$	FSMC_CLK low to FSMC_Ax valid (x = 16...23)	0	5	
$t_{d(CLKH\_AIV)}$	FSMC_CLK high to FSMC_Ax invalid (x = 16...23)	0	5	
$t_{d(CLKL\_NWE)}$	FSMC_CLK low to FSMC_NWE low	0		
$t_{d(CLKH\_NWEH)}$	FSMC_CLK high to FSMC_NWE high	0		
$t_{d(CLKL\_ADV)}$	FSMC_CLK low to FSMC_AD[15:0] valid	0	5	
$t_{d(CLKL\_ADIV)}$	FSMC_CLK low to FSMC_AD[15:0] invalid	0	5	
$t_{d(CLKL\_DATA)}$	FSMC_AD[15:0] valid after FSMC_CLK low	2		
$t_{su(NWAITV\_CLKH)}$	FSMC_NWAIT valid before FSMC_CLK high	6		
$t_{h(CLKH\_NWAITV)}$	FSMC_NWAIT valid after FSMC_CLK high	2		
$t_{d(CLKL\_NBLH)}$	FSMC_CLK low to FSMC_NBL high	2		

NAND controller waveform and timing

Test conditions: NAND operation area, 16-bit data width is selected, ECC calculation circuit is enabled, 512-byte page size, other timing configurations are setting registers FSMC\_PCR2=0x0002005E, FSMC\_PMEM2=0x01020301, FSMC\_PATT2=0x01020301.

Figure 4-20 NAND controller read waveform

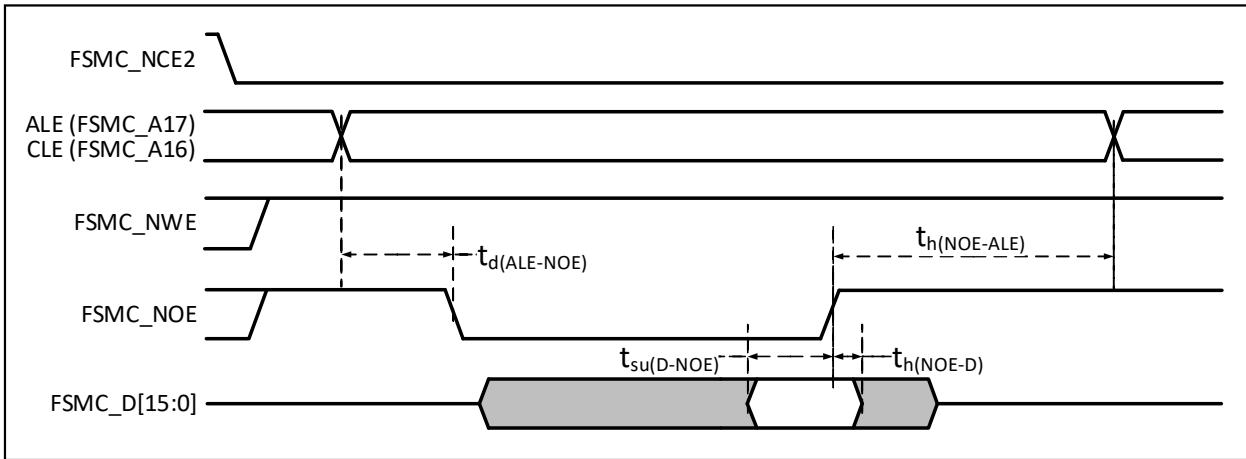

Figure 4-21 NAND controller write waveform

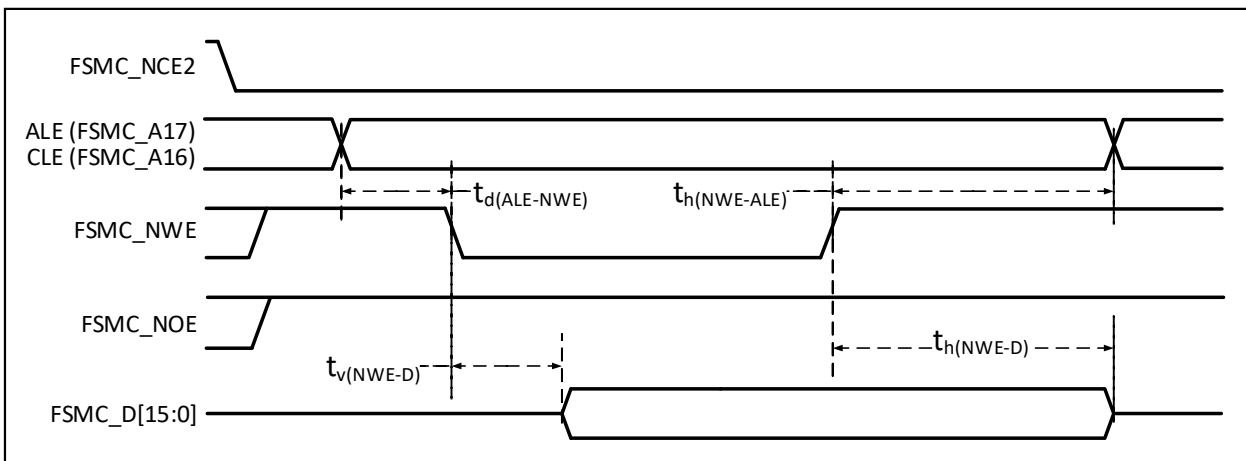

Figure 4-22 NAND controller read waveform in general-purpose storage space

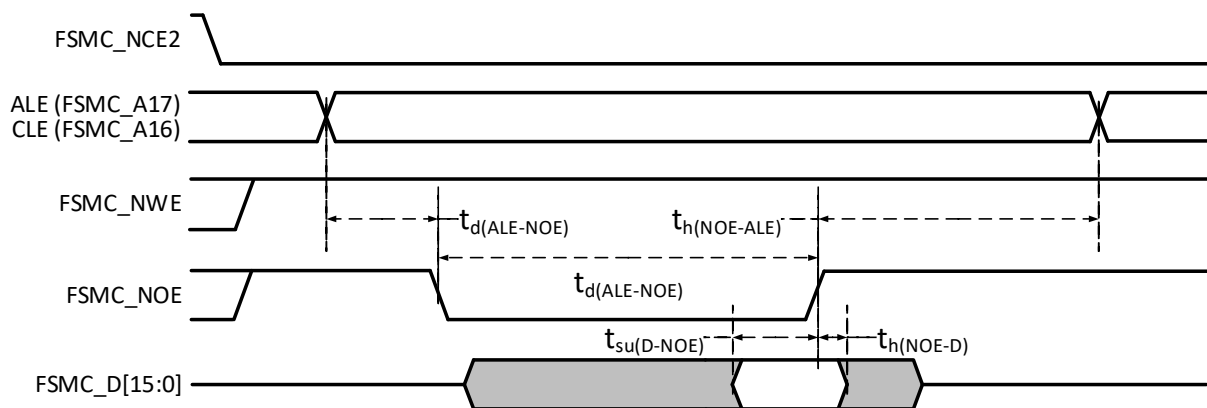

Figure 4-23 NAND controller write waveform in general-purpose storage space

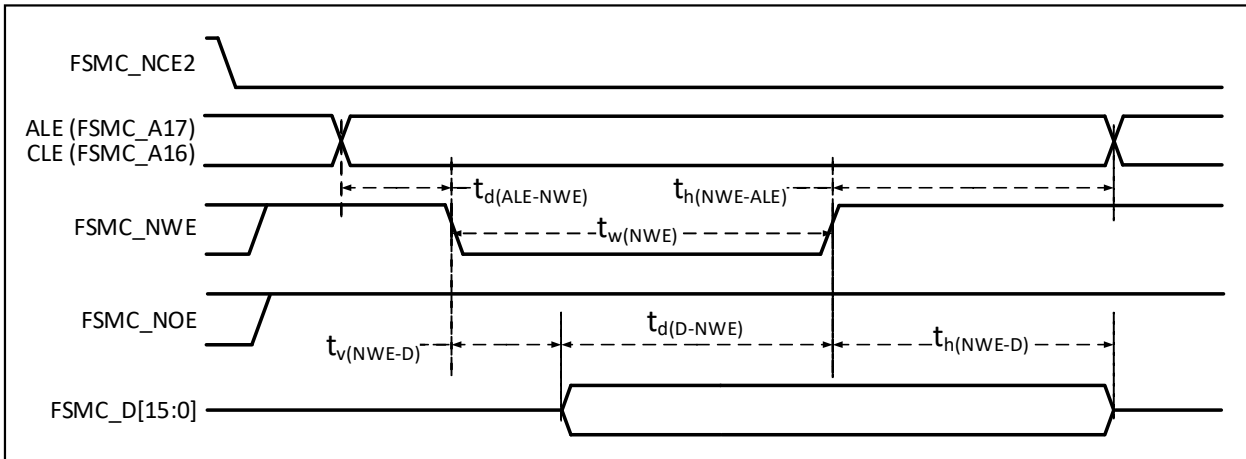

Table 4-34 Timing characteristics of NAND Flash read and write cycles

Symbol	Parameter	Min.	Max.	Unit
$t_{d(D-NWE)}$	Before FSMC_NWE high to FSMC_D[15:0] data valid	$4t_{HCLK}$		ns
$t_w(NOE)$	FSMC_NOE low time	$4t_{HCLK}$		
$t_{su(D-NOE)}$	Before FSMC_NOE high to FSMC_D[15:0] data valid	20		
$t_h(NOE-D)$	After FSMC_NOE high to FSMC_D[15:0] data valid	15		
$t_w(NWE)$	FSMC_NWE low time	$4t_{HCLK}$		
$t_v(NWE-D)$	FSMC_NWE low to FSMC_D[15:0] data valid	0		
$t_h(NWE-D)$	FSMC_NWE high to FSMC_D[15:0] data invalid	$2t_{HCLK}$		
$t_d(ALE-NWE)$	Before FSMC_NWE low to FSMC_ALE valid	$2t_{HCLK}$		
$t_h(NWE-ALE)$	FSMC_NWE high to FSMC_ALE invalid	$2t_{HCLK}$		
$t_d(ALE-NOE)$	Before FSMC_NOE low to FSMC_ALE valid	$2t_{HCLK}$		
$t_h(NOE-ALE)$	FSMC_NOE high to FSMC_ALE invalid	$4t_{HCLK}$		

### 4.3.19 DVP Interface Characteristics

Figure 4-24 DVP timing waveform

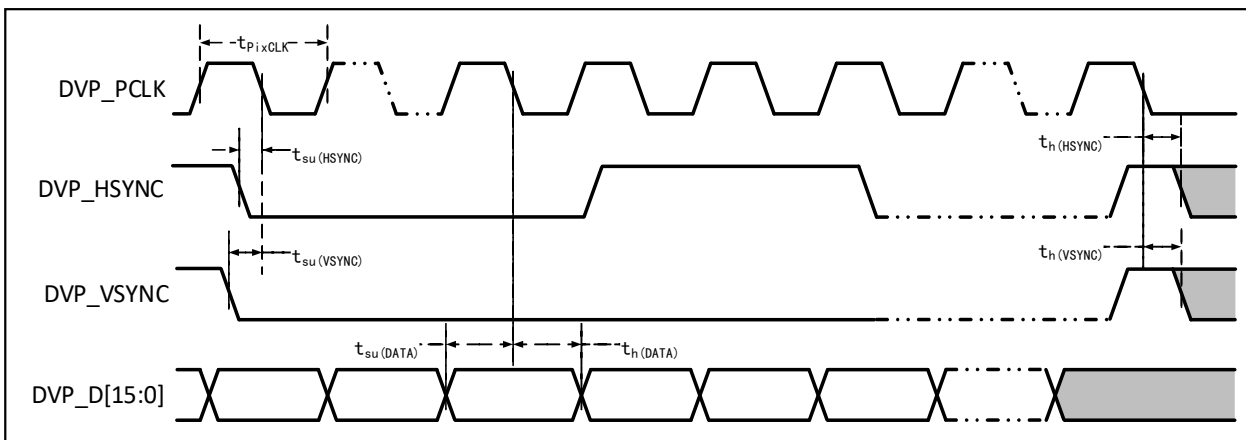

Table 4-35 DVP characteristics

Symbol	Parameter	Min.	Max.	Unit
$f_{\text{PIXCLK}}/t_{\text{PIXCLK}}$	Pixel clock input frequency		144	MHz
Duty(PiXCLK)	Pixel clock duty cycle	15		%
$t_{\text{su(DATA)}}$	Data setup time	2.5		ns
$t_{\text{h(DATA)}}$	Data hold time	1		
$t_{\text{su(HSYNC)/t_{su(VSYNC)}}$	HSYNC/VSYNC signal input setup time	2.5		
$t_{\text{h(HSYNC)/t_{h(VSYNC)}}$	HSYNC/VSYNC signal input hold time	1		

### 4.3.20 Gigabit Ethernet Interface Characteristics

Figure 4-25 ETH-SMI timing waveform

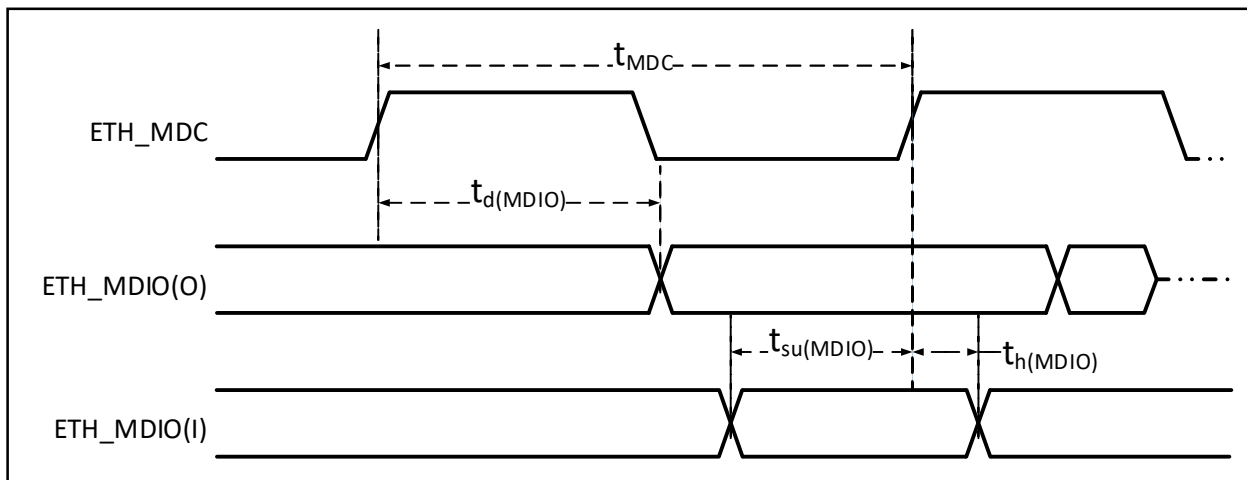

Table 4-36 SMI signal characteristics of Ethernet MAC

Symbol	Parameter	Min.	Typ.	Max.	Unit
$f_{\text{MDC}}/t_{\text{MDC}}$	MDC clock frequency			2.5	MHz
$t_{\text{d(MDIO)}}$	MDIO write data valid time	0		300	ns
$t_{\text{su(MDIO)}}$	Read data setup time	10			
$t_{\text{h(MDIO)}}$	Read data hold time	10			

Figure 4-26 ETH-RMII signal timing waveform

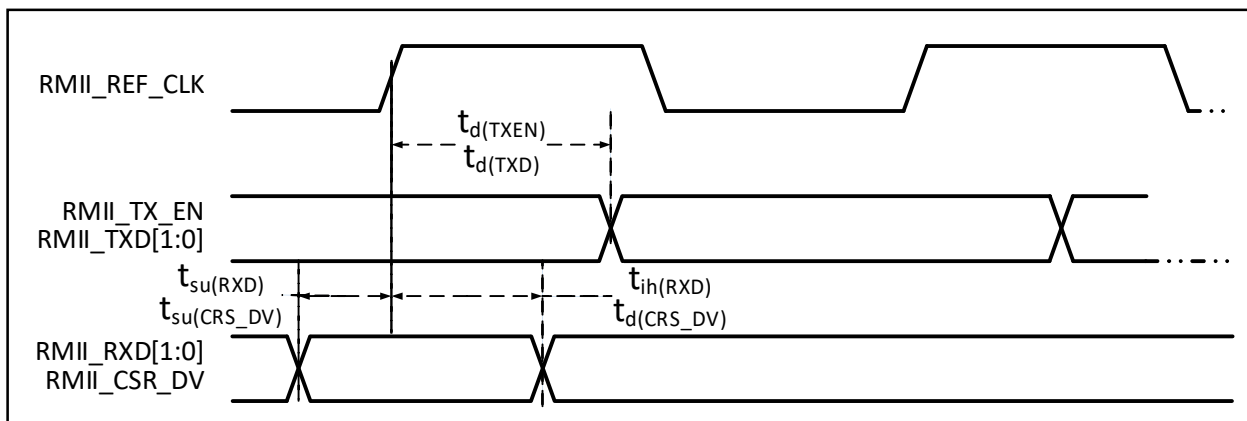

Table 4-37 RMII signal characteristics of Ethernet MAC

Symbol	Parameter	Min.	Typ.	Max.	Unit
$t_{su(RXD)}$	Setup time of received data	4			ns
$t_{ih(RXD)}$	Hold time of received data	2			
$t_{su(CRS\_DV)}$	Carrier detect signal setup time	4			
$t_{ih(CRS\_DV)}$	Carrier detect signal hold time	2			
$t_d(TXEN)$	Transmission enable effective delay time			16	
$t_d(TXD)$	Data transmission effective delay time			16	

Figure 4-27 ETH-MII signal timing waveform

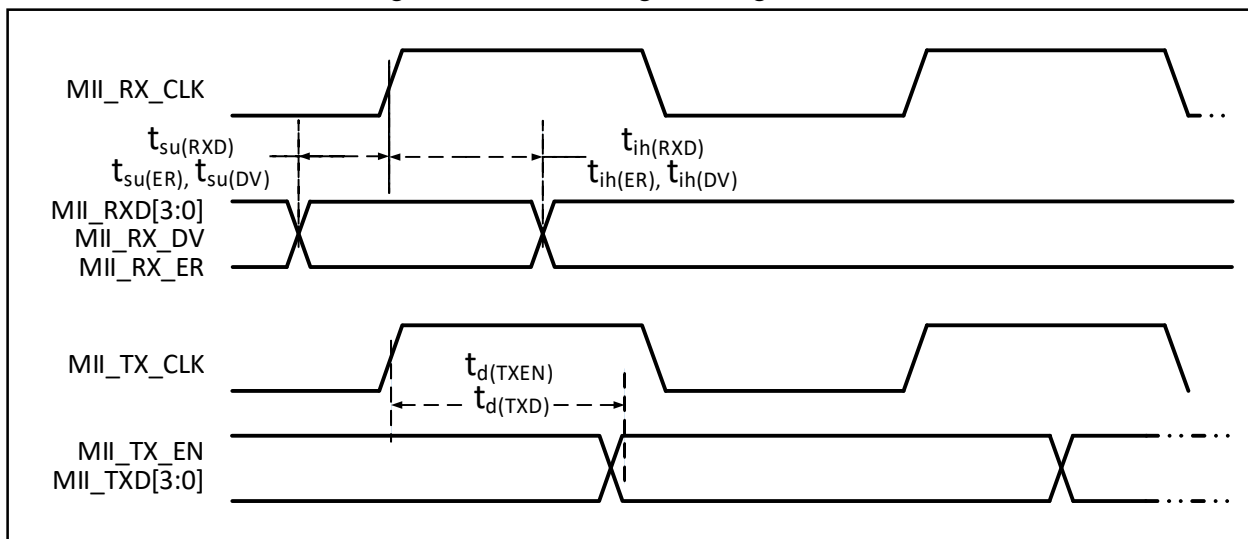

Table 4-38 MII signal characteristics of Ethernet MAC

Symbol	Parameter	Min.	Typ.	Max.	Unit
$t_{su(RXD)}$	Setup time of received data	10			ns
$t_{ih(RXD)}$	Hold time of received data	10			
$t_{su(DV)}$	Data valid signal setup time	10			
$t_{ih(DV)}$	Data valid signal hold time	10			
$t_{su(ER)}$	Error signal setup time	10			
$t_{ih(ER)}$	Error signal hold time	10			
$t_d(TXEN)$	Transmission enable effective delay time			16	
$t_d(TXD)$	Data transmission effective delay time			16	



Figure 4-28 ETH-RGMII signal timing waveform

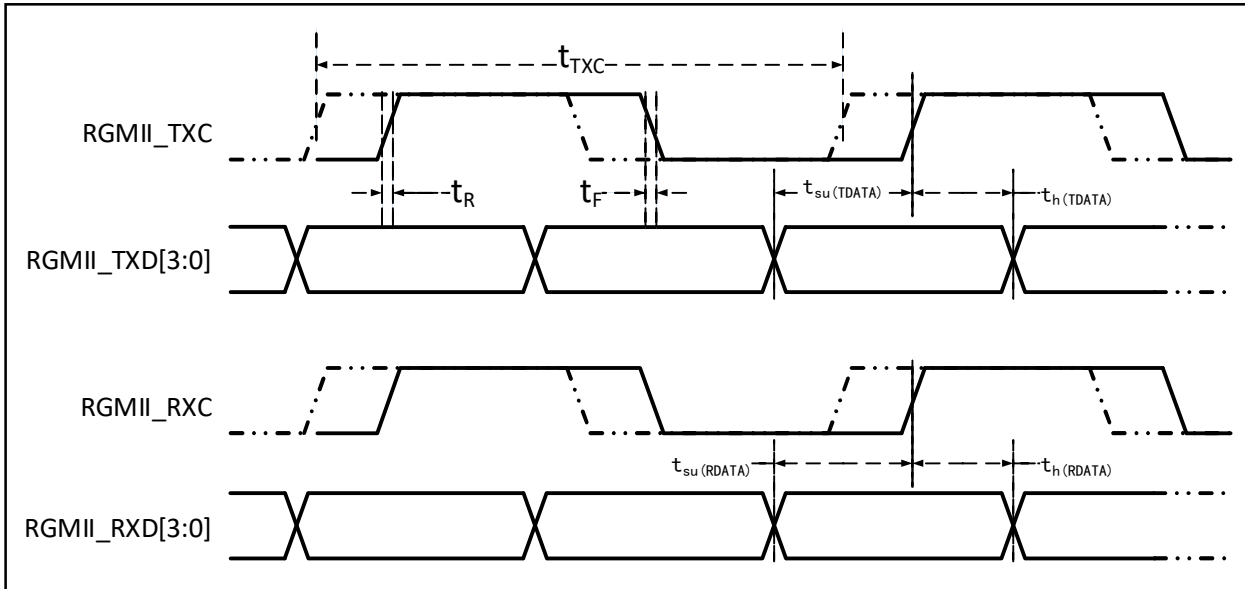

Table 4-39 RGMII signal characteristics of Ethernet MAC

Symbol	Parameter	Min.	Typ.	Max.	Unit
$f_{TXC}/t_{TXC}$	TXC/RXC clock frequency	7.2	8	8.8	ns
$t_R$	TXC/RXC rise time			2.0	
$t_F$	TXC/RXC fall time			2.0	
$t_{su}(TDATA)$	Transmit data setup time	1.2	2.0		
$t_h(TDATA)$	Transmit data hold time	1.2	2.0		
$t_{su}(RDATA)$	Input data setup time	1.2	2.0		
$t_h(RDATA)$	Input data hold time	1.2	2.0		

#### 4.3.21 12-bit ADC Characteristics

Table 4-40 ADC characteristics

Symbol	Parameter	Condition	Min.	Typ.	Max.	Unit
$V_{DDA}$	Supply voltage		2.4		3.6	V
$V_{REF+}$	Positive reference voltage	$V_{REF+}$ cannot be more than $V_{DDA}$	2.4		$V_{DDA}$	V
$I_{VREF}$	Reference current			160	220	uA
$I_{DDA}$	Supply current			480	530	uA
$f_{ADC}$	ADC clock frequency				14	MHz
$f_s$	Sampling rate		0.05		1	MHz
$f_{TRIG}$	External trigger frequency				16	$1/f_{ADC}$
$V_{AIN}$	Conversion voltage range		0		$V_{REF+}$	V
$R_{AIN}$	External input impedance				50	k $\Omega$
$R_{ADC}$	Sampling switch resistance			0.6	1	k $\Omega$
$C_{ADC}$	Internal sample and hold capacitor			8		pF

$t_{CAL}$	Calibration time			40		$1/f_{ADC}$
$t_{lat}$	Injected trigger conversion latency				2	$1/f_{ADC}$
$t_{latr}$	Regular trigger conversion latency				2	$1/f_{ADC}$
$t_s$	Sampling time		1.5		239.5	$1/f_{ADC}$
$t_{STAB}$	Power-on time				1	us
$t_{CONV}$	Total conversion time (including sampling time)		14		252	$1/f_{ADC}$

Note: Above parameters are guaranteed by design.

Formula: Maximum  $R_{AIN}$

$$R_{AIN} < \frac{T_s}{f_{ADC} \times C_{ADC} \times \ln 2^{N+2}} - R_{ADC}$$

The above formula is used to determine the maximum external impedance so that the error can be less than 1/4 LSB. Where N=12 (representing 12-bit resolution).

Table 4-41 Maximum  $R_{AIN}$  when  $f_{ADC} = 14\text{MHz}$

$T_s(\text{cycle})$	$t_s(\text{us})$	Maximum $R_{AIN}(\text{k}\Omega)$
1.5	0.11	0.4
7.5	0.54	5.9
13.5	0.96	11.4
28.5	2.04	25.2
41.5	2.96	37.2
55.5	3.96	50
71.5	5.11	Invalid
239.5	17.1	Invalid

Table 4-42 ADC error

Symbol	Parameter	Condition	Min.	Typ.	Max.	Unit
EO	Offset error	$f_{PCLK2} = 56\text{ MHz},$ $f_{ADC} = 14\text{ MHz},$ $R_{AIN} < 10\text{ k}\Omega,$ $V_{DDA} = 3.3\text{V}$		$\pm 2$		LSB
ED	Differential nonlinearity error			$\pm 0.5$	$\pm 3$	
EL	Integral nonlinearity error			$\pm 1$	$\pm 4$	

$C_p$  represents the parasitic capacitance on the PCB and the pad (about 5pF), which may be related to the quality of the pad and PCB layout. A larger  $C_p$  value will reduce the conversion accuracy, the solution is to reduce the  $f_{ADC}$  value.

Figure 4-29 ADC typical connection diagram

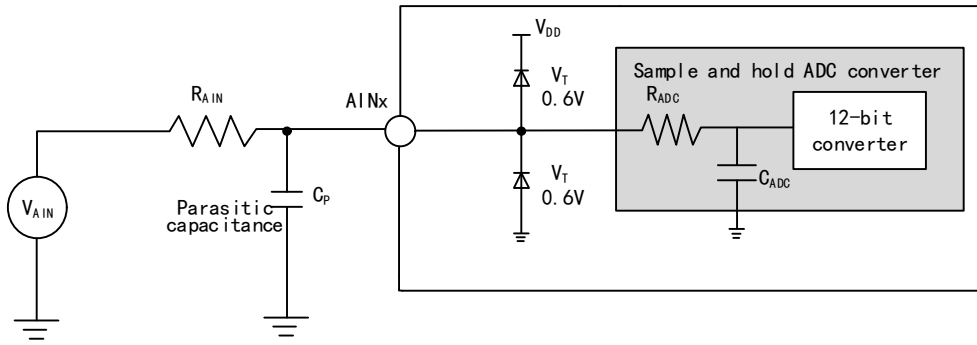
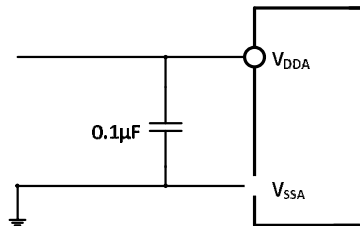

Figure 4-30 Analog power supply and decoupling circuit reference



### 4.3.22 Temperature Sensor Characteristics

Table 4-43 Temperature sensor characteristics

Symbol	Parameter	Condition	Min.	Typ.	Max.	Unit
R <sub>TS</sub>	Measurement range of temperature sensor		-40		85	°C
A <sub>TSC</sub>	Measurement range of temperature sensor after software calibration			±12		°C
Avg_Slope	Average slope (negative temperature coefficient)		3.8	4.3	4.7	mV/°C
V <sub>25</sub>	Voltage at 25°C		1.34	1.40	1.46	V
T <sub>S_temp</sub>	ADC sampling time when reading temperature	f <sub>ADC</sub> = 14MHz			17.1	us

### 4.3.23 DAC Characteristics

Table 4-44 DAC characteristics

Symbol	Parameter	Condition	Min.	Typ.	Max.	Unit
V <sub>DDA</sub>	Supply voltage		2.4	3.3	3.6	V
V <sub>REF+</sub>	Positive reference voltage	V <sub>REF+</sub> ≤ V <sub>DDA</sub>	2.4	3.3	3.6	V
R <sub>L</sub> <sup>(1)</sup>	Resistive load with buffer ON		5			kΩ
C <sub>L</sub> <sup>(1)</sup>	Capacitive load with buffer ON				50	pF
V <sub>OUT_MIN</sub> <sup>(1)</sup>	12-bit DAC conversion with buffer		0		8	mV
V <sub>OUT_MAX</sub> <sup>(1)</sup>	ON	V <sub>REF+</sub> = 3.3V	3.29		3.3	V
V <sub>OUT_MIN</sub> <sup>(1)</sup>	12-bit DAC conversion with buffer		0		3	mV

$V_{OUT\_MAX}^{(1)}$	OFF	$V_{REF+}=3.3V$	3.295		3.3	V	
$I_{V_{REF+}}$	With no load, 0x800 on the inputs			58		uA	
	With no load, 0xF1C at $V_{REF+}=3.6V$ on the inputs			194			
	With no load, 0x555 (worst) at $V_{REF+}=3.6V$ on the inputs			331			
$I_{DDA}$	With buffer ON and no load, 0x800 on the inputs			170		uA	
	With buffer ON and no load, 0xF1C on the inputs at $V_{REF+}=3.6V$ ,			150			
	With buffer ON and no load, 0x555 (worst) at $V_{REF+}=3.6V$ on the inputs			170			
DNL	Differential nonlinearity error			$\pm 2$		LSB	
INL	Integral nonlinearity error		After calibration of offset error and gain error	$\pm 4$		LSB	
Offset	Offset error			$\pm 3$	$\pm 12$	mV	
			$V_{REF+}=3.6V$		$\pm 10$	LSB	
Gain error		DAC in 12-bit configuration		$\pm 0.4$		%	
Amplifier gain <sup>(1)</sup>	Amplifier gain in open loop		5k $\Omega$ load (max)	80	85	dB	
$t_{SETTLING}$	Setting time (full scale: for an input code transition between the lowest and the highest input codes when DAC_OUT reaches final value $\pm 1$ LSB)		$C_{LOAD} \leq 50pF$ $R_{LOAD} \geq 5k\Omega$		3	4	us
Update rate	Max frequency for a correct DAC_OUT change when small variation in the input code (from code i to i+1LSB),		$C_{LOAD} \leq 50pF$ $R_{LOAD} \geq 5k\Omega$			1	MS/s
$t_{WAKEUP}$	Time to wake up from off state (PDV18 changes from 1 to 0)		$C_{LOAD} \leq 50pF$ , $R_{LOAD} \geq 5k\Omega$ , input codes between the lowest and highest possible ones		6.5	10	us
PSRR <sup>(1)</sup>	Power supply rejection ratio (relative to $V_{DDA}$ ) (static DC measurement)		No $R_{LOAD}$ , $C_{LOAD} \leq 50pF$		-100	-75	dB

Note: 1. Guaranteed by design, not tested in production.

#### 4.3.24 OPA Characteristics

Table 4-45 OPA characteristics

Symbol	Parameter	Condition	Min.	Typ.	Max.	Unit
--------	-----------	-----------	------	------	------	------

$V_{DDA}$	Supply voltage		2.4	3.3	3.6	V
$C_{MIR}$	Common mode input voltage		0		$V_{DDA}-0.9$	V
$V_{IOFFSET}$	Input offset voltage			1.5	6	mV
$I_{LOAD}$	Drive current				600	uA
$I_{DDOPAMP}$	Current consumption	No load, static mode		195		uA
$C_{MRR}^{(1)}$	Common mode rejection ratio	@1KHz		96		dB
$P_{SRR}^{(1)}$	Power supply rejection ratio	@1KHz		86		dB
$A_V^{(1)}$	Open loop gain	$C_{LOAD}=5pF$		136		dB
$G_{BW}^{(1)}$	Unit gain bandwidth	$C_{LOAD}=5pF$		19		MHz
$P_M^{(1)}$	Phase margin	$C_{LOAD}=5pF$		93		
$S_R^{(1)}$	Slew rate limited	$C_{LOAD}=5pF$		8		V/us
$t_{WAKUP}^{(1)}$	Setup time from shutdown to wake up, 0.1%	Input $V_{DDA}/2$ , $C_{LOAD}=5pF$ , $R_{LOAD}=4k\Omega$			368	ns
$R_{LOAD}$	Resistive load		4			k $\Omega$
$C_{LOAD}$	Capacitive load				50	pF
$V_{OHSAT}^{(2)}$	High saturation output voltage	$R_{LOAD}=4k\Omega$ , input $V_{DDA}$	$V_{DDA}-45$			mV
		$R_{LOAD}=20k\Omega$ , input $V_{DDA}$	$V_{DDA}-10$			
$V_{OLSAT}^{(2)}$	Low saturation output voltage	$R_{LOAD}=4k\Omega$ , input 0			0.5	mV
		$R_{LOAD}=20k\Omega$ , input 0			0.5	
$EN^{(1)}$	Equivalent input voltage noise	$R_{LOAD}=4k\Omega$ , @1KHz		83		$\frac{nv}{\sqrt{Hz}}$
		$R_{LOAD}=4k\Omega$ , @10KHz		42		

Note: 1. The source simulation is not a real measurement.

2. The load current limits the saturated output voltage.

## Chapter 5 Package and Ordering Information

### Packages

Part No.	Package	Body size	Lead pitch	Description	Packing type
CH32V303CBT6	LQFP48	7*7mm	0.5mm	Low Profile Quad Flat Pack	Tray
CH32V303RBT6	LQFP64M	10*10mm	0.5mm	Low Profile Quad Flat Pack	Tray
CH32V303RCT6	LQFP64M	10*10mm	0.5mm	Low Profile Quad Flat Pack	Tray
CH32V303VCT6	LQFP100	14*14mm	0.5mm	Low Profile Quad Flat Pack	Tray
CH32V305FBP6	TSSOP20	4.4*6.5mm	0.65mm	Thin Shrink Small Outline Package	Tube
CH32V305GBU6	QFN28	4*4mm	0.4mm	Quad Flat No-Lead Package	Tray
CH32V305RBT6	LQFP64M	10*10mm	0.5mm	Low Profile Quad Flat Pack	Tray
CH32V307RCT6	LQFP64M	10*10mm	0.5mm	Low Profile Quad Flat Pack	Tray
CH32V307WCU6	QFN68X8	8*8mm	0.4mm	Quad Flat No-Lead Package	Tray
CH32V307VCT6	LQFP100	14*14mm	0.5mm	Low Profile Quad Flat Pack	Tray

Note: 1. The packing type of QFP/QFN is usually tray.

2. Size of tray: The size of Tray is generally a uniform size (322.6\*135.9\*7.62). There are differences in the size of the restriction holes for different package types, and there are differences between different packaging factories for tubes, please confirm with the manufacturer for details.

Note: All dimensions are in millimeters. The pin center spacing values are nominal values, with no error. Other than that, the dimensional error is not greater than the greater of  $\pm 0.2\text{mm}$  or 10%.

Figure 5-1 TSSOP20 package

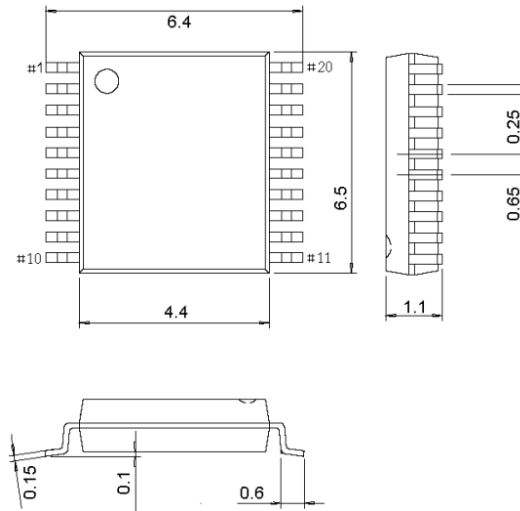

Figure 5-2 QFN68X8 package

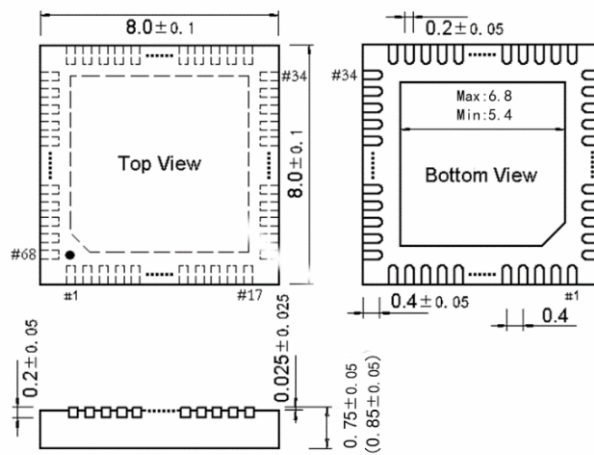

Figure 5-3 QFN28 package

Figure 5-4 LQFP48 package

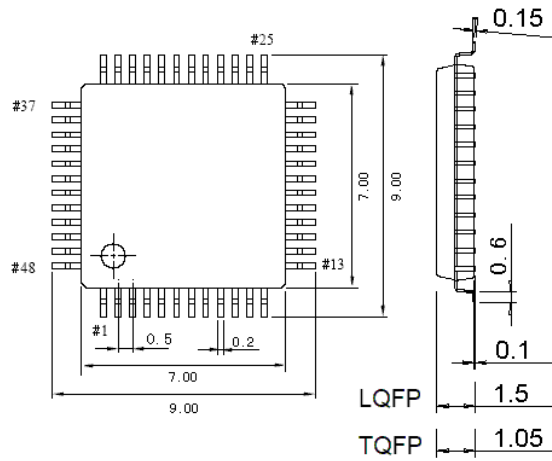

Figure 5-5 LQFP64M package

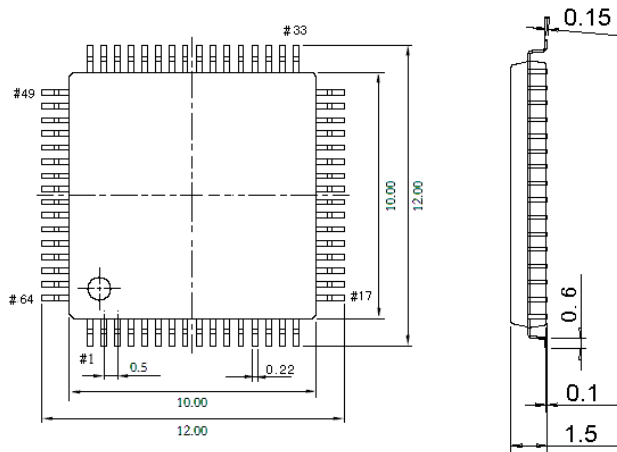

Figure 5-6 LQFP100 package



## Series Product Naming Rules

Example:	CH32	V	3	03	R	8	T	6
Device family								
F = ARM-based, general-purpose MCU								
V = QingKe RISC-V-based, general-purpose MCU								
L = QingKe RISC-V-based, low power MCU								
X = QingKe RISC-V-based, Dedicated architecture or special IO								
Product type								
0 = QingKe V2/V4 core, main frequency @48M								
1 = M3/ QingKe V3/V4 core, main frequency @72M								
2 = M3/ QingKe V4 non-floating-point core, main frequency @144M								
3 = QingKe V4F floating-point core, main frequency @144M								
Device subfamily								
03 = General-purpose								
05 = Connectivity (USB high-speed, SDIO, dual CAN)								
07 = Interconnectivity (USB high-speed, dual CAN, Ethernet, DVP, SDIO, FSMC)								
08 = Wireless (BLE5.X, CAN, USB, Ethernet)								
35 = Connectivity (USB, USB PD)								
Pin count								
J = 8 pins	A = 16 pins	F = 20 pins						
G = 28 pins	K = 32 pins	T = 36 pins						
C = 48 pins	R = 64 pins	W = 68 pins						
V = 100 pins	Z = 144 pins							
Flash memory size								
4 = 16 Kbytes of Flash memory								
6 = 32 Kbytes of Flash memory								
7 = 48 Kbytes of Flash memory								
8 = 64 Kbytes of Flash memory								
B = 128 Kbytes of Flash memory								
C = 256 Kbytes of Flash memory								
Package								
T = LQFP	U = QFN	R = QSOP	P = TSSOP	M = SOP				
Temperature range								
6 = -40°C~85°C (industrial-grade)								
7 = -40°C~105°C (automotive-grade 2)								
3 = -40°C~125°C (automotive-grade 1)								
D = -40°C~150°C (automotive-grade 0)								