



# SPECIFICATION FOR APPROVAL



CUSTOMER P/N	B65807J0400J087	PART NO:	P3 RM6 AL400
DATE	2023-10-07	TEMPERATURE	25 °C
HUMIDITY	48%		

## 1. DIMENSIONS:(mm)

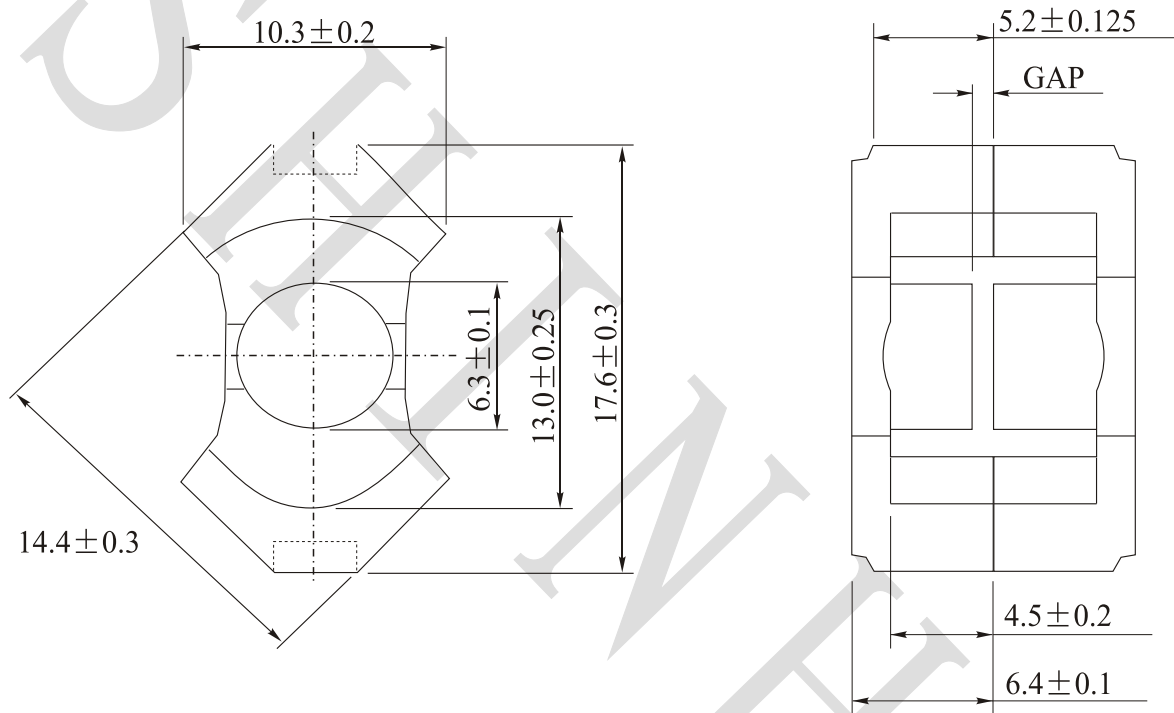

## 2. ELECTRICAL CHARACTERISTICS

AL nH	C1 mm <sup>-1</sup>	Le mm	Ae mm <sup>2</sup>	Ve mm <sup>3</sup>	Wt g/set
400±10%	0.78	28.6	36.6	1050	5.44
TEST CONDITIONS	AL: F=10KHz U=0.1V T=25°C ±3°C N=100Ts Φ0.2mm				
TESTING EQUIPMENT	HP4284A	CH-258	HP 34401A		

Initial permeability: 2300±25%

PRPARED BY		APPROVED BY	
------------	--	-------------	--

www.shinhom.com

NO.8,YanTa Northern road,xi'anCity Shaanxi pro.china TEL: +86-29-87851916 FAX: +86-29-87851840 E-mail: sales@shinhom.com.cn