

Features

- Sealed construction (housing sealing according to DIN IEC 68 part 2 - 17 Qc2)
- Additional models and versions available; e.g., locking bushing for locking the shaft
- Cermet resistive element

0620 - Rotary Potentiometer

Characteristics

Mechanical Angle 285 ° +0 %/-5 °
 Starting Torque 0.5 to 1.5 Ncm
 End Stop Strength 40 Ncm max.
 Shaft Push-Pull Force 50 N max.
 Resistance Range 100 ohms to 1 megohm
 Resistance Curve Linear
 Power Rating 1 W
 Temperature Range -55 °C to +125 °C
 Rotational Life 25,000 cycles
 Moisture Sensitivity Level 1
 ESD Classification (HBM) N/A

Standard Resistance Table

Resistance (Ohms)	Resistance Code
100	101
220	221
470	471
1,000	102
2,200	222
4,700	472
10,000	103
22,000	223
47,000	473
100,000	104
220,000	224
470,000	474
1,000,000	105

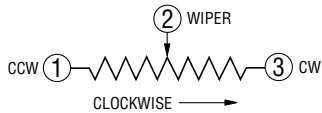

Bushing Dimensions

Dim.	Bushing Type		
	H	U	G
B	5.0 ± 0.05 (.197 ± .002)	8.0 ± 0.05 (.315 ± .002)	12.0 ± 0.05 (.472 ± .002)

Product Dimensions

0620-013 (H or U Bushing)

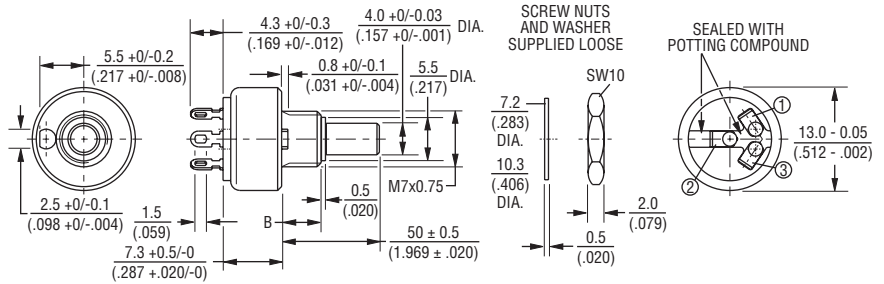

0620-057 (G Bushing Only)

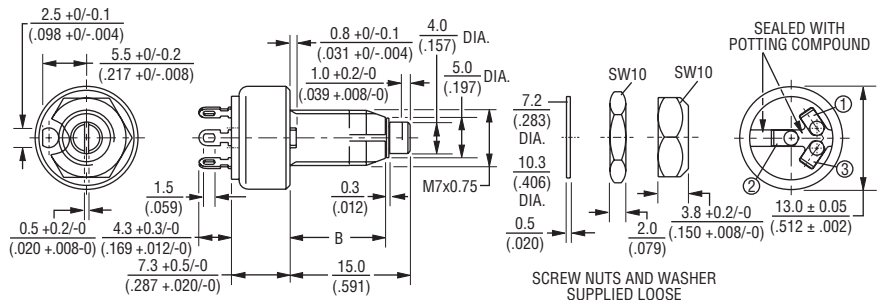

0620-313 (H or U Bushing)

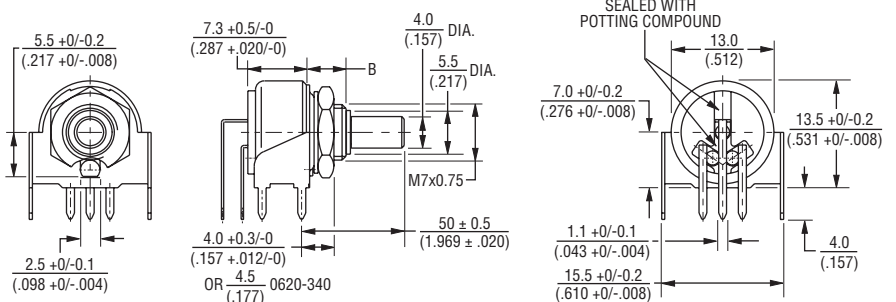

Recommended PCB Layout

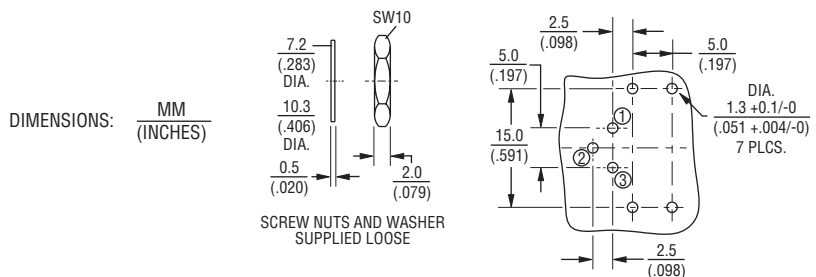

*RoHS Directive 2002/95/EC Jan. 27, 2003 including annex and RoHS Recast 2011/65/EU June 8, 2011. Specifications are subject to change without notice.

Users should verify actual device performance in their specific applications.

The products described herein and this document are subject to specific legal disclaimers set forth on the last page of this document, and at www.bourns.com/docs/legal/disclaimer.pdf.

0620 - Rotary Potentiometer

BOURNS®

Product Dimensions

0620-613 (H or U Bushing)

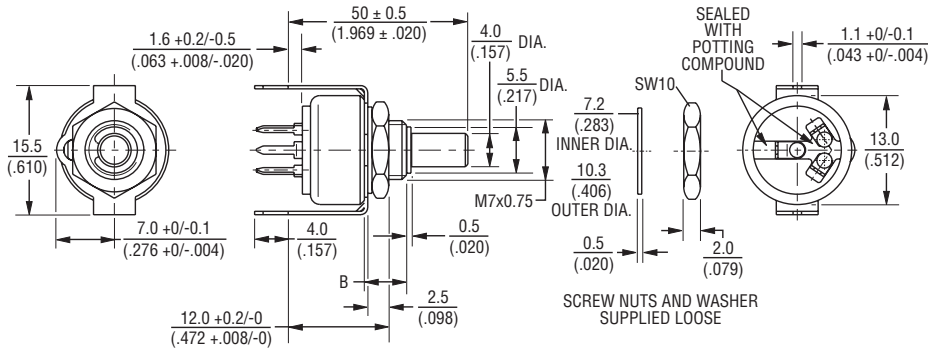

Recommended PCB Layout

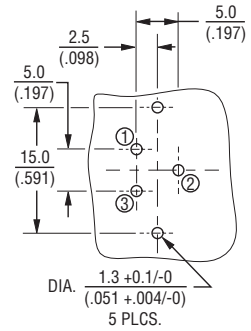

DIMENSIONS: $\frac{\text{MM}}{\text{(INCHES)}}$

How to Order

0620 - 013 U 500 - A B 103

Model Type 0620

Terminal Style 013 (Sealed, available with H & U bushing types only)

057 (Locking bushing, Available with G bushing type only)

313 (Available with H & U bushing types only)

613 (Available with H & U bushing types only)

Other versions available upon request.

Bushing & Shaft Type U = 7 mm D x 8 mm L, Shaft 4 mm D

H = 7 mm D x 5 mm L, Shaft 4 mm D

G = 7 mm D x 12 mm L, Shaft 4 mm D

Shaft Length 500 = 50 mm

Other lengths available upon request.

Independent Linearity A = ±5 %

Other versions available upon request.

Element Taper B = Linear Cermet ±20 %

E = Linear Cermet ±10 %

L = Linear Cermet ± 5 %

Resistance Code _____

Other versions available upon request.

REV. 08/17

Specifications are subject to change without notice.

Users should verify actual device performance in their specific applications.

The products described herein and this document are subject to specific legal disclaimers set forth on the last page of this document, and at www.bourns.com/docs/legal/disclaimer.pdf.

Legal Disclaimer Notice

BOURNS®

This legal disclaimer applies to purchasers and users of Bourns® products manufactured by or on behalf of Bourns, Inc. and its affiliates (collectively, “Bourns”).

Unless otherwise expressly indicated in writing, Bourns® products and data sheets relating thereto are subject to change without notice. Users should check for and obtain the latest relevant information before placing orders and should verify that such information is current and complete.

The characteristics and parameters of a Bourns® product set forth in its data sheet are based on laboratory conditions and statements regarding the suitability of products for certain types of applications are based on Bourns’ knowledge of typical requirements in generic applications. The characteristics and parameters of a Bourns® product in a user application may vary from the data sheet characteristics and parameters due to a combination of the Bourns® product with other components in the user’s application or due to the environment of the user application itself. Such characteristics and parameters also can and do vary in different applications and actual performance may vary over time. Users should always verify actual performance of the Bourns® product in their specific devices and applications, and make their own independent judgments about how much additional test margin to design in to compensate for differences between laboratory and real world conditions.

Unless Bourns has explicitly designated an individual Bourns® product as meeting the requirements of a particular industry standard (e.g., ISO/TS 16949) or a particular qualification (e.g., UL listed or recognized), Bourns is not responsible for any failure of an individual Bourns® product to meet such industry standard requirements or particular qualification. Users of Bourns® products are responsible for ensuring compliance with safety-related requirements and standards applicable to their applications.

Bourns® products are not recommended, authorized or intended for use in nuclear, military, lifesaving, life-critical or life sustaining applications, nor in any other applications where failure or malfunction may result in personal injury, death, or severe property or environmental damage. Unless expressly and specifically approved in writing by two authorized Bourns representatives on a case-by-case basis, use of any Bourns® products in such unauthorized applications is at the user’s sole risk. Life-critical applications include devices identified by the U.S. Food and Drug Administration as Class III devices and generally equivalent classifications outside of the United States.

Bourns® standard products that are designed and tested for use in automotive applications will be described on the applicable data sheets as compliant with the applicable AEC-Q standard. Use of any other Bourns® standard products in an automotive application is not recommended, authorized or intended and will be at the user’s sole risk.

Bourns® standard products are not tested to comply with the United States Federal Aviation Administration or any other generally equivalent governmental organization standard applicable to products designed or manufactured for use in aircraft or space applications. Bourns® standard products that are designed and tested for use in aircraft or space applications will be described on the applicable data sheets as compliant with the RTCA DO-160 standard. Use of any other Bourns® standard product in an aircraft or space application is not recommended, authorized or intended and will be at the user’s sole risk.

The use and level of testing applicable to Bourns® custom products shall be negotiated on a case-by-case basis by Bourns and the user for which such Bourns® custom products are specially designed. Absent a written agreement between Bourns and the user regarding the use and level of testing, the provisions above applicable to Bourns® standard products shall also apply to such Bourns® custom products.

Users shall not sell, transfer, export or re-export any Bourns® products or technology for use in activities which involve the design, development, production, use or stockpiling of nuclear, chemical or biological weapons or missiles, nor use Bourns® products or technology in any facility which engages in activities relating to such devices. The foregoing restrictions apply to all uses and applications that violate national or international prohibitions, including embargos or international regulations. Further, Bourns® products, technology or technical data may not under any circumstance be exported or re-exported to countries subject to international sanctions or embargoes and Bourns® products may not, without prior authorization from Bourns and/or the U.S. Government, be resold, transferred, or re-exported to any party that is ineligible to receive U.S. commodities, software, or technical data.

To the maximum extent permitted by applicable law, Bourns disclaims (i) any and all liability arising out of the application or use of any Bourns® standard product, (ii) any and all liability, including, without limitation, special, punitive, consequential or incidental damages, and (iii) any and all implied warranties, including implied warranties of fitness for particular purpose, non-infringement and merchantability.