

**8 Gb, 1-bit ECC, x8 I/O, 3 V, V_{CC} NAND
Flash Memory for Embedded**

General Description

The Cypress S34ML08G1 8-Gb NAND is offered in 3.3 V_{CC} with x8 I/O interface. This document contains information for the S34ML08G1 device, which is a dual-die stack of two S34ML04G1 die. For detailed specifications, please refer to the discrete die datasheet: [S34ML04G1](#).

Distinctive Characteristics

- Density
 - 8 Gb (4 Gb × 2)
- Architecture (For each 4 Gb device)
 - Input / Output Bus Width: 8-bits
 - Page Size: (2048 + 64) bytes; 64 bytes is spare area
 - Block Size: 64 Pages or (128k + 4k) bytes
 - Plane Size
 - 2048 Blocks per Plane or (256M + 8M) bytes
 - Device Size
 - 2 Planes per Device or 512 Mbyte
- NAND Flash Interface
 - Open NAND Flash Interface (ONFI) 1.0 compliant
 - Address, Data and Commands multiplexed
- Supply Voltage
 - 3.3 V device: V_{CC} = 2.7 V ~ 3.6 V
- Security
 - One Time Programmable (OTP) area
 - Hardware program/erase disabled during power transition
- Additional Features
 - Supports Multiplane Program and Erase commands
 - Supports Copy Back Program
 - Supports Multiplane Copy Back Program
 - Supports Read Cache
- Electronic Signature
 - Manufacturer ID: 01h
- Operating Temperature
 - Industrial: –40 °C to 85 °C
 - Automotive: –40 °C to 105 °C

Performance

- Page Read / Program
 - Random access: 25 μs (Max)
 - Sequential access: 25 ns (Min)
 - Program time / Multiplane Program time: 200 μs (Typ)
- Block Erase / Multiplane Erase (S34ML04G1)
 - Block Erase time: 3.5 ms (Typ)
- Reliability
 - 100,000 Program / Erase cycles (Typ)
(with 1 bit / 512 + 16 byte ECC)
 - 10 Year Data retention (Typ)
 - Blocks zero and one are valid and will be valid for at least 1000 program-erase cycles with ECC
- Package Options
 - Lead Free and Low Halogen
 - 48-Pin TSOP 12 × 20 × 1.2 mm
 - 63-Ball BGA 9 × 11 × 1 mm

Contents

General Description	1
Distinctive Characteristics	1
Performance	1
1. Connection Diagram	3
2. Pin Description	5
3. Block Diagrams	6
4. Addressing	8
5. Read Status Enhanced	8
6. Extended Read Status	8
7. Read ID	9
7.1 Read Parameter Page	10
8. Electrical Characteristics	12
8.1 Valid Blocks	12
8.2 Recommended Operating Conditions.....	12
8.3 DC Characteristics	13
8.4 Pin Capacitance.....	13
8.5 Power Consumptions and Pin Capacitance for Allowed Stacking Configurations	13
9. Physical Interface	14
9.1 Physical Diagram	14
10. Ordering Information	16
11. Appendix A — Errata	17
12. Revision History	18

1. Connection Diagram

Figure 1.1 48-Pin TSOP1 Contact x8 Device (1 CE 8 Gb)

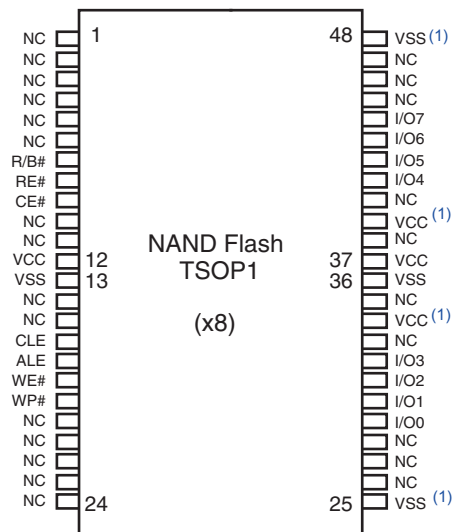

Note:

1. These pins should be connected to power supply or ground (as designated) following the ONFI specification, however they might not be bonded internally.

Figure 1.2 48-Pin TSOP1 Contact x8 Device (2 CE 8 Gb)

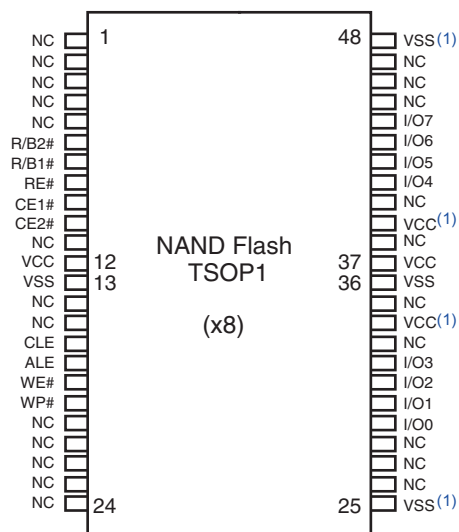

Note:

1. These pins should be connected to power supply or ground (as designated) following the ONFI specification, however they might not be bonded internally.

Figure 1.3 63-BGA Contact, x8 Device, Single CE (Top View)

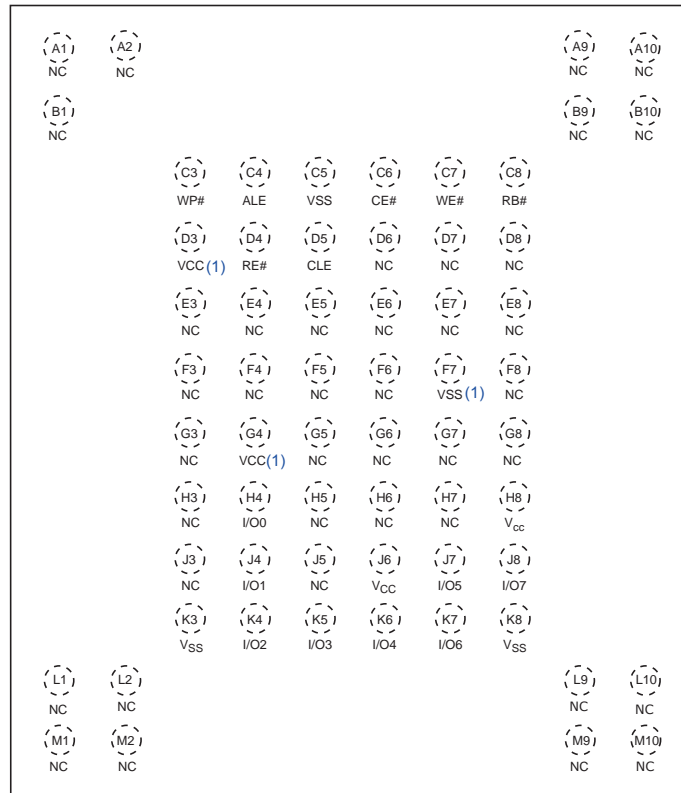

Note:

1. These pins should be connected to power supply or ground (as designated) following the ONFI specification, however they might not be bonded internally.

2. Pin Description

Table 2.1 Pin Description

Pin Name	Description
I/O0 - I/O7	Inputs/Outputs. The I/O pins are used for command input, address input, data input, and data output. The I/O pins float to High-Z when the device is deselected or the outputs are disabled.
CLE	Command Latch Enable. This input activates the latching of the I/O inputs inside the Command Register on the rising edge of Write Enable (WE#).
ALE	Address Latch Enable. This input activates the latching of the I/O inputs inside the Address Register on the rising edge of Write Enable (WE#).
CE#	Chip Enable. This input controls the selection of the device. When the device is not busy CE# low selects the memory.
WE#	Write Enable. This input latches Command, Address and Data. The I/O inputs are latched on the rising edge of WE#.
RE#	Read Enable. The RE# input is the serial data-out control, and when active drives the data onto the I/O bus. Data is valid t_{REA} after the falling edge of RE# which also increments the internal column address counter by one.
WP#	Write Protect. The WP# pin, when low, provides hardware protection against undesired data modification (program / erase).
R/B#	Ready Busy. The Ready/Busy output is an Open Drain pin that signals the state of the memory.
VCC	Supply Voltage. The V_{CC} supplies the power for all the operations (Read, Program, Erase). An internal lock circuit prevents the insertion of Commands when V_{CC} is less than V_{LKO} .
VSS	Ground.
NC	Not Connected.

Notes:

1. A 0.1 μ F capacitor should be connected between the V_{CC} Supply Voltage pin and the V_{SS} Ground pin to decouple the current surges from the power supply. The PCB track widths must be sufficient to carry the currents required during program and erase operations.
2. An internal voltage detector disables all functions whenever V_{CC} is below 1.8V to protect the device from any involuntary program/erase during power transitions.

3. Block Diagrams

Figure 3.1 Functional Block Diagram — 4 Gb

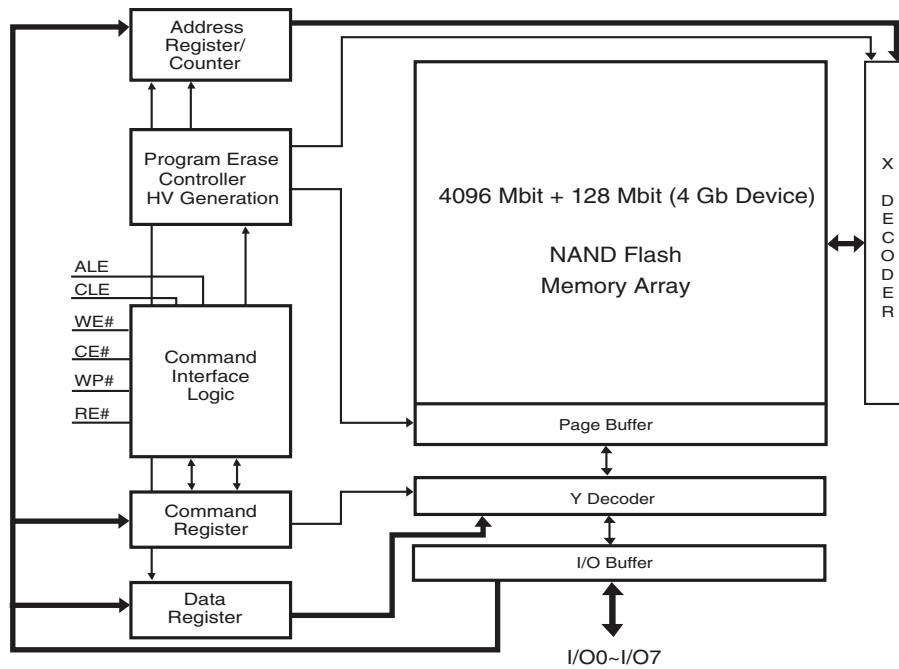

Figure 3.2 Block Diagram — 1 CE (4 Gb x 8)

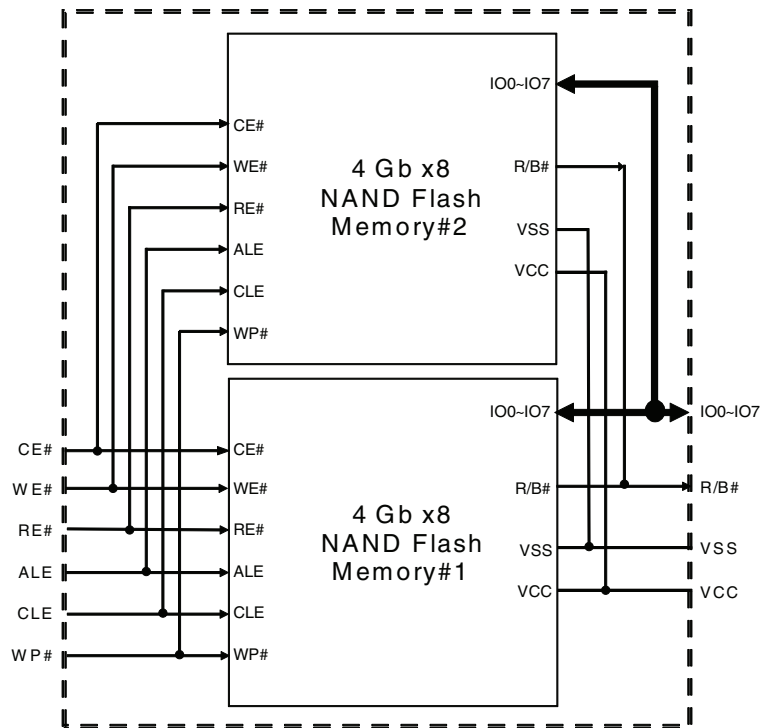
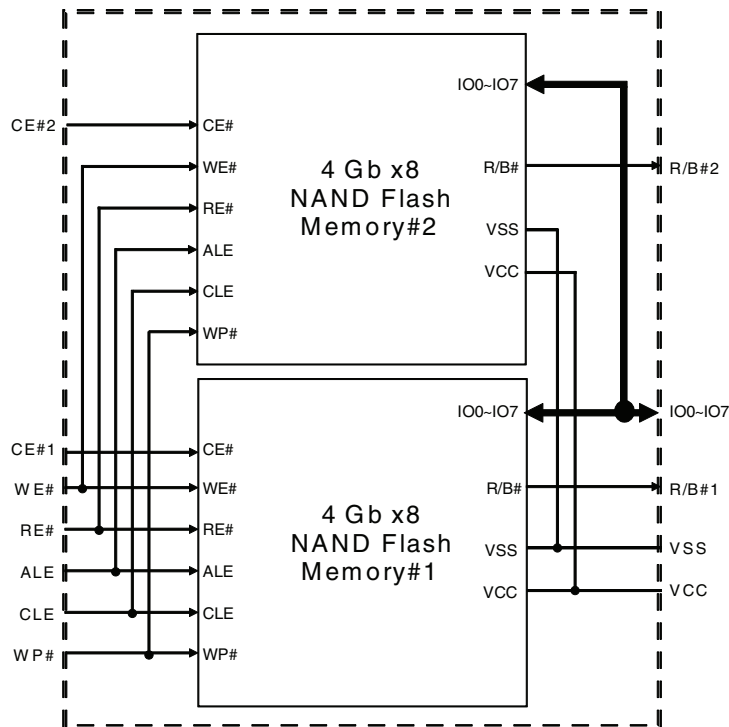

Figure 3.3 Block Diagram — 2 CE (4 Gb x 8)



4. Addressing

Table 4.1 Address Cycle Map

Bus Cycle	I/O0	I/O1	I/O2	I/O3	I/O4	I/O5	I/O6	I/O7
1st / Col. Add. 1	A0 (CA0)	A1 (CA1)	A2 (CA2)	A3 (CA3)	A4 (CA4)	A5 (CA5)	A6 (CA6)	A7 (CA7)
2nd / Col. Add. 2	A8 (CA8)	A9 (CA9)	A10 (CA10)	A11 (CA11)	Low	Low	Low	Low
3rd / Row Add. 1	A12 (PA0)	A13 (PA1)	A14 (PA2)	A15 (PA3)	A16 (PA4)	A17 (PA5)	A18 (PLA0)	A19 (BA0)
4th / Row Add. 2	A20 (BA1)	A21 (BA2)	A22 (BA3)	A23 (BA4)	A24 (BA5)	A25 (BA6)	A26 (BA7)	A27 (BA8)
5th / Row Add. 3 (6)	A28 (BA9)	A29 (BA10)	A30 (BA11)	Low	Low	Low	Low	Low

Notes:

1. CAx = Column Address bit.
2. PAx = Page Address bit.
3. PLA0 = Plane Address bit zero.
4. BAx = Block Address bit.
5. Block address concatenated with page address and plane address = actual page address, also known as the row address.
6. A30 for 8 Gb (4 Gb x 2 – DDP) (1CE).

For the address bits, the following rules apply:

- A0 - A11: column address in the page
- A12 - A17: page address in the block
- A18: plane address (for multiplane operations) / block address (for normal operations)
- A19 - A30: block address

5. Read Status Enhanced

Read Status Enhanced is used to retrieve the status value for a previous operation in the following cases:

- In the case of concurrent operations on a multi-die stack.

When two dies are stacked to form a dual-die package (DDP), it is possible to run one operation on the first die, then activate a different operation on the second die, for example: Erase while Read, Read while Program, etc.

- In the case of multiplane operations in the same die.

6. Extended Read Status

Multi-die stack devices support the Extended Read Status operation. When two operations are active in separate dies at the same time, this feature allows the host to check the status of a given die. For example, the first die could be executing a Page Program while the second die is performing a Page Read. Refer to [Table 6.1](#) for a description of each command.

Table 6.1 Extended Read Status

Command	Die	Row Address with 4 Gb Dies
F2h	First	0 to 3FFFFh
F3h	Second	40000h to 7FFFFh

7. Read ID

The device contains a product identification mode, initiated by writing 90h to the command register, followed by an address input of 00h.

Note: If you want to execute Read Status command (0x70) after Read ID sequence, you should input dummy command (0x00) before Read Status command (0x70).

For the S34ML04G1 device, five read cycles sequentially output the manufacturer code (01h), and the device code and 3rd, 4th, and 5th cycle ID, respectively. The command register remains in Read ID mode until further commands are issued to it.

Table 7.1 Read ID for Supported Configurations (1)

Density	Org	V _{CC}	1st	2nd	3rd	4th	5th
4 Gb	x8	3.3V	01h	DCh	90h	95h	54h
8 Gb (4 Gb x 2 – DDP with two CE#)	x8	3.3V	01h	DCh	90h	95h	54h
8 Gb (4 Gb x 2 – DDP with one CE#) (1)	x8	3.3V	01h	D3h	D1h	95h	58h

Note:

1. See See Appendix A — Errata on page 17. for information on READ ID in MCPs.

Figure 7.1 Read ID Operation Timing — 8 Gb

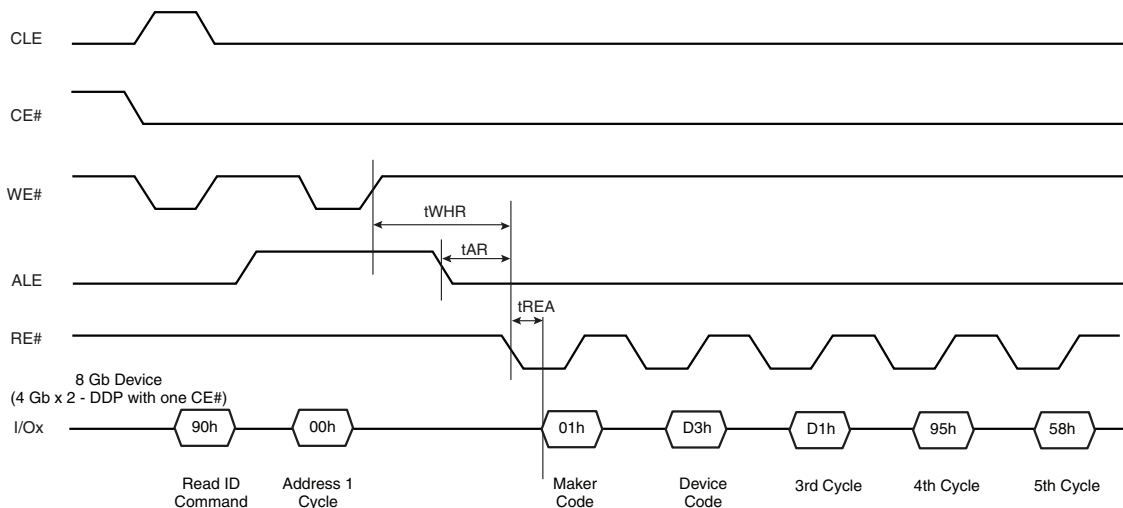

5th ID Data

Table 7.2 Read ID Byte 5 Description — S34ML04G1

	Description	I/O7	I/O6 I/O5 I/O4	I/O3 I/O2	I/O1	I/O0
Plane Number	1			0 0		
	2			0 1		
	4			1 0		
	8			1 1		
Plane Size (without spare area)	64 Mb		0 0 0			
	128 Mb		0 0 1			
	256 Mb		0 1 0			
	512 Mb		0 1 1			
	1 Gb		1 0 0			
	2 Gb		1 0 1			
	4 Gb		1 1 0			
8 Gb		1 1 1				
Reserved		0			0	0

7.1 Read Parameter Page

The device supports the ONFI Read Parameter Page operation, initiated by writing ECh to the command register, followed by an address input of 00h. The command register remains in Parameter Page mode until further commands are issued to it. Table 7.3 explains the parameter fields.

Note: For 41nm 2Gb/4Gb Cypress NAND, for a particular condition, the Read Parameter Page command does not give the correct values. To overcome this issue, the host must issue a Reset command before the Read Parameter Page command. Issuance of Reset before the Read Parameter Page command will provide the correct values and will not output 00h values. This does not apply to 48nm 1Gb.

Table 7.3 Parameter Page Description (Sheet 1 of 3)

Byte	O/M	Description	Values
Revision Information and Features Block			
0-3	M	Parameter page signature Byte 0: 4Fh, "O" Byte 1: 4Eh, "N" Byte 2: 46h, "F" Byte 3: 49h, "I"	4Fh, 4Eh, 46h, 49h
4-5	M	Revision number 2-15 Reserved (0) 1 1 = supports ONFI version 1.0 0 Reserved (0)	02h, 00h
6-7	M	Features supported 5-15 Reserved (0) 4 1 = supports odd to even page Copyback 3 1 = supports interleaved operations 2 1 = supports non-sequential page programming 1 1 = supports multiple LUN operations 0 1 = supports 16-bit data bus width	1Eh, 00h
8-9	M	Optional commands supported 6-15 Reserved (0) 5 1 = supports Read Unique ID 4 1 = supports Copyback 3 1 = supports Read Status Enhanced 2 1 = supports Get Features and Set Features 1 1 = supports Read Cache commands 0 1 = supports Page Cache Program command	1Bh, 00h
10-31		Reserved (0)	00h

Table 7.3 Parameter Page Description (Sheet 2 of 3)

Byte	O/M	Description	Values
Manufacturer Information Block			
32-43	M	Device manufacturer (12 ASCII characters)	53h, 50h, 41h, 4Eh, 53h, 49h, 4Fh, 4Eh, 20h, 20h, 20h, 20h
44-63	M	Device model (20 ASCII characters)	53h, 33h, 34h, 4Dh, 4Ch, 30h, 38h, 47h, 31h, 20h, 20h, 20h, 20h, 20h, 20h, 20h, 20h, 20h, 20h
64	M	JEDEC manufacturer ID	01h
65-66	O	Date code	00h
67-79		Reserved (0)	00h
Memory Organization Block			
80-83	M	Number of data bytes per page	00h, 08h, 00h, 00h
84-85	M	Number of spare bytes per page	40h, 00h
86-89	M	Number of data bytes per partial page	00h, 02h, 00h, 00h
90-91	M	Number of spare bytes per partial page	10h, 00h
92-95	M	Number of pages per block	40h, 00h, 00h, 00h
96-99	M	Number of blocks per logical unit (LUN)	00h, 10h, 00h, 00h
100	M	Number of logical units (LUNs)	02h
101	M	Number of address cycles 4-7 Column address cycles 0-3 Row address cycles	23h
102	M	Number of bits per cell	01h
103-104	M	Bad blocks maximum per LUN	50h, 00h
105-106	M	Block endurance	01h, 05h
107	M	Guaranteed valid blocks at beginning of target	01h
108-109	M	Block endurance for guaranteed valid blocks	01h, 03h
110	M	Number of programs per page	04h
111	M	Partial programming attributes 5-7 Reserved 4 1 = partial page layout is partial page data followed by partial page spare 1-3 Reserved 0 1 = partial page programming has constraints	00h
112	M	Number of bits ECC correctability	01h
113	M	Number of interleaved address bits 4-7 Reserved (0) 0-3 Number of interleaved address bits	01h
114	O	Interleaved operation attributes 4-7 Reserved (0) 3 Address restrictions for program cache 2 1 = program cache supported 1 1 = no block address restrictions 0 Overlapped / concurrent interleaving support	04h
115-127		Reserved (0)	00h
Electrical Parameters Block			
128	M	I/O pin capacitance	0Ah
129-130	M	Timing mode support 6-15 Reserved (0) 5 1 = supports timing mode 5 4 1 = supports timing mode 4 3 1 = supports timing mode 3 2 1 = supports timing mode 2 1 1 = supports timing mode 1 0 1 = supports timing mode 0, shall be 1	1Fh, 00h

Table 7.3 Parameter Page Description (Sheet 3 of 3)

Byte	O/M	Description	Values
131-132	O	Program cache timing mode support 6-15 Reserved (0) 5 1 = supports timing mode 5 4 1 = supports timing mode 4 3 1 = supports timing mode 3 2 1 = supports timing mode 2 1 1 = supports timing mode 1 0 1 = supports timing mode 0	1Fh, 00h
133-134	M	t _{PROG} Maximum page program time (μs)	BCh, 02h
135-136	M	t _{BERS} Maximum block erase time (μs)	10h, 27h
137-138	M	t _R Maximum page read time (μs)	19h, 00h
139-140	M	t _{CCS} Minimum Change Column setup time (ns)	64h, 00h
141-163		Reserved (0)	00h
Vendor Block			
164-165	M	Vendor specific Revision number	00h
166-253		Vendor specific	00h
254-255	M	Integrity CRC	7Bh, 09h
Redundant Parameter Pages			
256-511	M	Value of bytes 0-255	Repeat Value of bytes 0-255
512-767	M	Value of bytes 0-255	Repeat Value of bytes 0-255
768+	O	Additional redundant parameter pages	FFh

Note:

1. "O" Stands for Optional, "M" for Mandatory.

8. Electrical Characteristics

8.1 Valid Blocks

Table 8.1 Valid Blocks — 4 Gb

Device	Symbol	Min	Typ	Max	Unit
S34ML04G1	N _{VB}	4016	—	4096	Blocks
S34ML08G1	N _{VB}	8032 (1)	—	8192	Blocks

Note:

1. Each 4 Gb has maximum 80 bad blocks.

8.2 Recommended Operating Conditions

Table 8.2 Recommended Operating Conditions

Parameter	Symbol	Min	Typ	Max	Units
Vcc Supply Voltage	Vcc	2.7	3.3	3.6	V
Ground Supply Voltage	Vss	0	0	0	V

8.3 DC Characteristics

Table 8.3 DC Characteristics and Operating Conditions

(Values listed are for each 4 Gb NAND, 8 Gb (4 Gb x 2) will be additive accordingly)

Parameter		Symbol	Test Conditions	Min	Typ	Max	Units
Power-On Current		I_{CC0}	Power up Current	—	15	30	mA
Operating Current	Sequential Read	I_{CC1}	$t_{RC} = t_{RC}(\text{min}), CE\# = V_{IL}, I_{OUT} = 0 \text{ mA}$	—	15	30	mA
	Program	I_{CC2}	Normal	—	—	30	mA
			Cache	—	—	40	mA
Erase	I_{CC3}	—	—	—	15	30	mA
Standby current, (TTL)		I_{CC4}	$CE\# = V_{IH}, WP\# = 0/V_{CC}$	—	—	1	mA
Standby current, (CMOS)		I_{CC5}	$CE\# = V_{CC}-0.2, WP\# = 0/V_{CC}$	—	10	50	μA
Input Leakage Current		I_{LI}	$V_{IN} = 0 \text{ to } 3.6\text{V}$	—	—	± 10	μA
Output Leakage Current		I_{LO}	$V_{OUT} = 0 \text{ to } 3.6\text{V}$	—	—	± 10	μA
Input High Voltage		V_{IH}	—	$V_{CC} \times 0.8$	—	$V_{CC} + 0.3$	V
Input Low Voltage		V_{IL}	—	-0.3	—	$V_{CC} \times 0.2$	V
Output High Voltage		V_{OH}	$I_{OH} = -400 \mu\text{A}$	2.4	—	—	V
Output Low Voltage		V_{OL}	$I_{OL} = 2.1 \text{ mA}$	—	—	0.4	V
Output Low Current (R/B#)		$I_{OL(R/B\#)}$	$V_{OL} = 0.4\text{V}$	8	10	—	mA
Erase and Program Lockout Voltage		V_{LKO}	—	—	1.8	—	V

Notes:

1. All V_{CC} pins, and V_{SS} pins respectively, are shorted together.
2. Values listed in this table refer to the complete voltage range for V_{CC} and to a single device in case of device stacking.
3. All current measurements are performed with a 0.1 μF capacitor connected between the V_{CC} Supply Voltage pin and the V_{SS} Ground pin.
4. Standby current measurement can be performed after the device has completed the initialization process at power-up.

8.4 Pin Capacitance

Table 8.4 Pin Capacitance (TA = 25°C, f=1.0 MHz)

Parameter	Symbol	Test Condition	Min	Max	Unit
Input	C_{IN}	$V_{IN} = 0\text{V}$	—	10	pF
Input / Output	C_{IO}	$V_{IL} = 0\text{V}$	—	10	pF

Note:

1. For the stacked devices version the Input is 10 pF x [number of stacked chips] and the Input/Output is 10 pF x [number of stacked chips].

8.5 Power Consumptions and Pin Capacitance for Allowed Stacking Configurations

When multiple dies are stacked in the same package, the power consumption of the stack will increase according to the number of chips. As an example, the standby current is the sum of the standby currents of all the chips, while the active power consumption depends on the number of chips concurrently executing different operations.

When multiple dies are stacked in the same package the pin/ball capacitance for the single input and the single input/output of the combo package must be calculated based on the number of chips sharing that input or that pin/ball.

9. Physical Interface

9.1 Physical Diagram

9.1.1 48-Pin Thin Small Outline Package (TSOP1)

Figure 9.1 TS2 48 — 48-lead Plastic Thin Small Outline, 12 x 20 mm, Package Outline

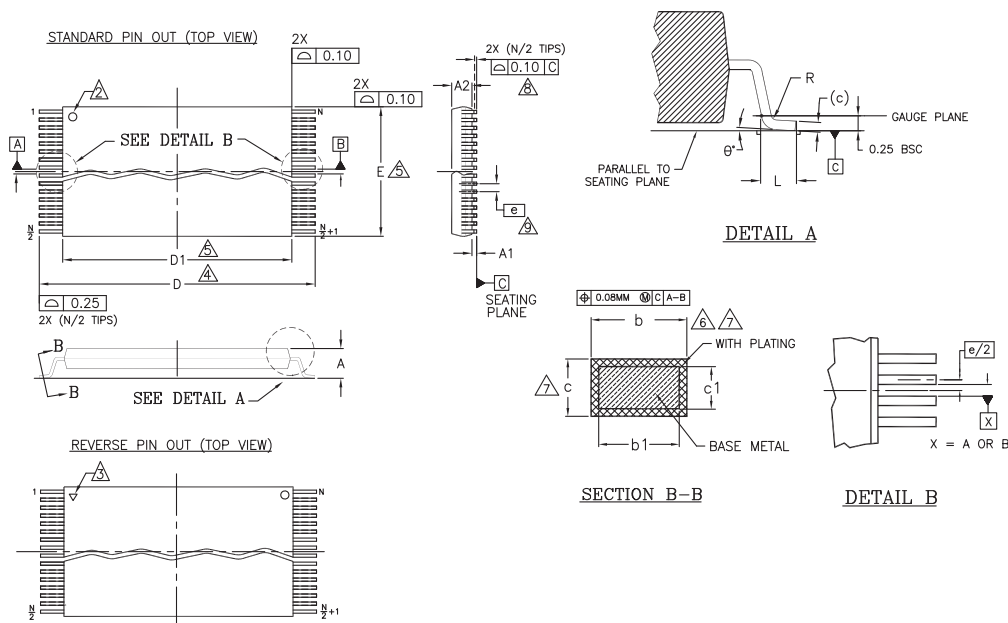

PACKAGE	TS2 48		
JEDEC	MO-142 (D) DD		
SYMBOL	MIN	NOM	MAX
A	---	---	1.20
A1	0.05	---	0.15
A2	0.95	1.00	1.05
b1	0.17	0.20	0.23
b	0.17	0.22	0.27
c1	0.10	---	0.16
c	0.10	---	0.21
D	19.80	20.00	20.20
D1	18.30	18.40	18.50
E	11.90	12.00	12.10
e	0.50 BASIC		
L	0.50	0.60	0.70
theta	0°	---	8
R	0.08	---	0.20
N	48		

NOTES:

1. DIMENSIONS ARE IN MILLIMETERS (mm). (DIMENSIONING AND TOLERANCING CONFORM TO ANSI Y14.5M-1994).
2. PIN 1 IDENTIFIER FOR STANDARD PIN OUT (DIE UP).
3. PIN 1 IDENTIFIER FOR REVERSE PIN OUT (DIE DOWN); INK OR LASER MARK.
4. TO BE DETERMINED AT THE SEATING PLANE [C], THE SEATING PLANE IS DEFINED AS THE PLANE OF CONTACT THAT IS MADE WHEN THE PACKAGE LEADS ARE ALLOWED TO REST FREELY ON A FLAT HORIZONTAL SURFACE.
5. DIMENSIONS D1 AND E DO NOT INCLUDE MOLD PROTRUSION. ALLOWABLE MOLD PROTRUSION ON E IS 0.15mm PER SIDE AND ON D1 IS 0.25mm PER SIDE.
6. DIMENSION b DOES NOT INCLUDE DAMBAR PROTRUSION. ALLOWABLE DAMBAR PROTRUSION SHALL BE 0.08mm TOTAL IN EXCESS OF b DIMENSION AT MAX. MATERIAL CONDITION. DAMBAR CANNOT BE LOCATED ON LOWER RADIUS OR THE FOOT. MINIMUM SPACE BETWEEN PROTRUSION AND AN ADJACENT LEAD TO BE 0.07mm.
7. THESE DIMENSIONS APPLY TO THE FLAT SECTION OF THE LEAD BETWEEN 0.10mm AND 0.25mm FROM THE LEAD TIP.
8. LEAD COPLANARITY SHALL BE WITHIN 0.10mm AS MEASURED FROM THE SEATING PLANE.
9. DIMENSION "e" IS MEASURED AT THE CENTERLINE OF THE LEADS.

5007 \ f16-038 \ 6.5.13

9.1.2 63-Pin Ball Grid Array (BGA)

Figure 9.2 VLD063 — 63-Pin BGA, 11 mm x 9 mm Package

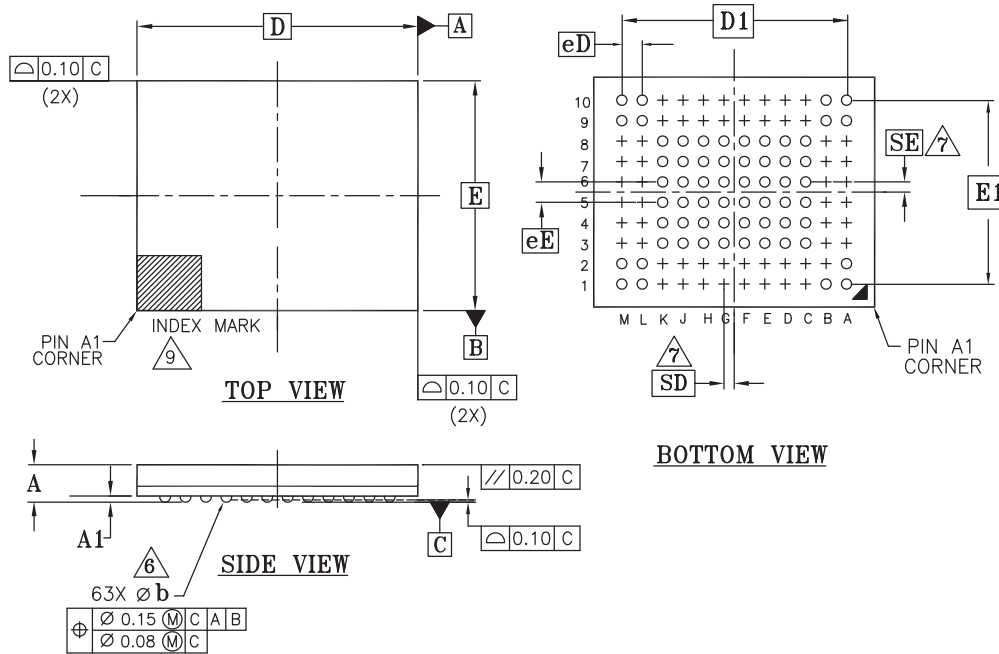

PACKAGE	VLD 063			NOTE
JEDEC	M0-207(M)			
11.00 mm x 9.00 mm PACKAGE				
SYMBOL	MIN	NOM	MAX	
A	---	---	1.00	PROFILE
A1	0.25	---	---	BALL HEIGHT
D	11.00 BSC.			BODY SIZE
E	9.00 BSC.			BODY SIZE
D1	8.80 BSC.			MATRIX FOOTPRINT
E1	7.20 BSC.			MATRIX FOOTPRINT
MD	12			MATRIX SIZE D DIRECTION
ME	10			MATRIX SIZE E DIRECTION
n	63			BALL COUNT
ø b	0.40	0.45	0.50	BALL DIAMETER
eE	0.80 BSC.			BALL PITCH
eD	0.80 BSC.			BALL PITCH
SD	0.40 BSC.			SOLDER BALL PLACEMENT
SE	0.40 BSC.			SOLDER BALL PLACEMENT
	A3-A8,B2-B8,C1,C2,C9,C10 D1,D2,D9,D10,E1,E2,E9,E10 F1,F2,F9,F10,G1,G2,G9,G10 H1,H2,H9,H10,J1,J2,J9,J10 K1,K2,K9,K10 L3-L8,M3-M8			DEPOPULATED SOLDER BALLS

NOTES:

- DIMENSIONING AND TOLERANCING METHODS PER ASME Y14.5M-1994.
- ALL DIMENSIONS ARE IN MILLIMETERS.
- BALL POSITION DESIGNATION PER JEP95, SECTION 3, SPP-020.
- [e] REPRESENTS THE SOLDER BALL GRID PITCH.
- SYMBOL "MD" IS THE BALL MATRIX SIZE IN THE "D" DIRECTION.

SYMBOL "ME" IS THE BALL MATRIX SIZE IN THE "E" DIRECTION.

n IS THE TOTAL NUMBER OF POPULATED SOLDER BALL POSITIONS FOR MATRIX SIZE MD X ME.

6 DIMENSION "b" IS MEASURED AT THE MAXIMUM BALL DIAMETER IN A PLANE PARALLEL TO DATUM C.

7 "SD" AND "SE" ARE MEASURED WITH RESPECT TO DATUMS A AND B AND DEFINE THE POSITION OF THE CENTER SOLDER BALL IN THE OUTER ROW.

WHEN THERE IS AN ODD NUMBER OF SOLDER BALLS IN THE OUTER ROW "SD" OR "SE" = 0.

WHEN THERE IS AN EVEN NUMBER OF SOLDER BALLS IN THE OUTER ROW, "SD" = eD/2 AND "SE" = eE/2.

8 "*" INDICATES THE THEORETICAL CENTER OF DEPOPULATED BALLS.

9 A1 CORNER TO BE IDENTIFIED BY CHAMFER, LASER OR INK MARK, METALLIZED MARK INDENTATION OR OTHER MEANS.

g5013 \ 16-038.28 \ 6.5.13

10. Ordering Information

The ordering part number is formed by a valid combination of the following:

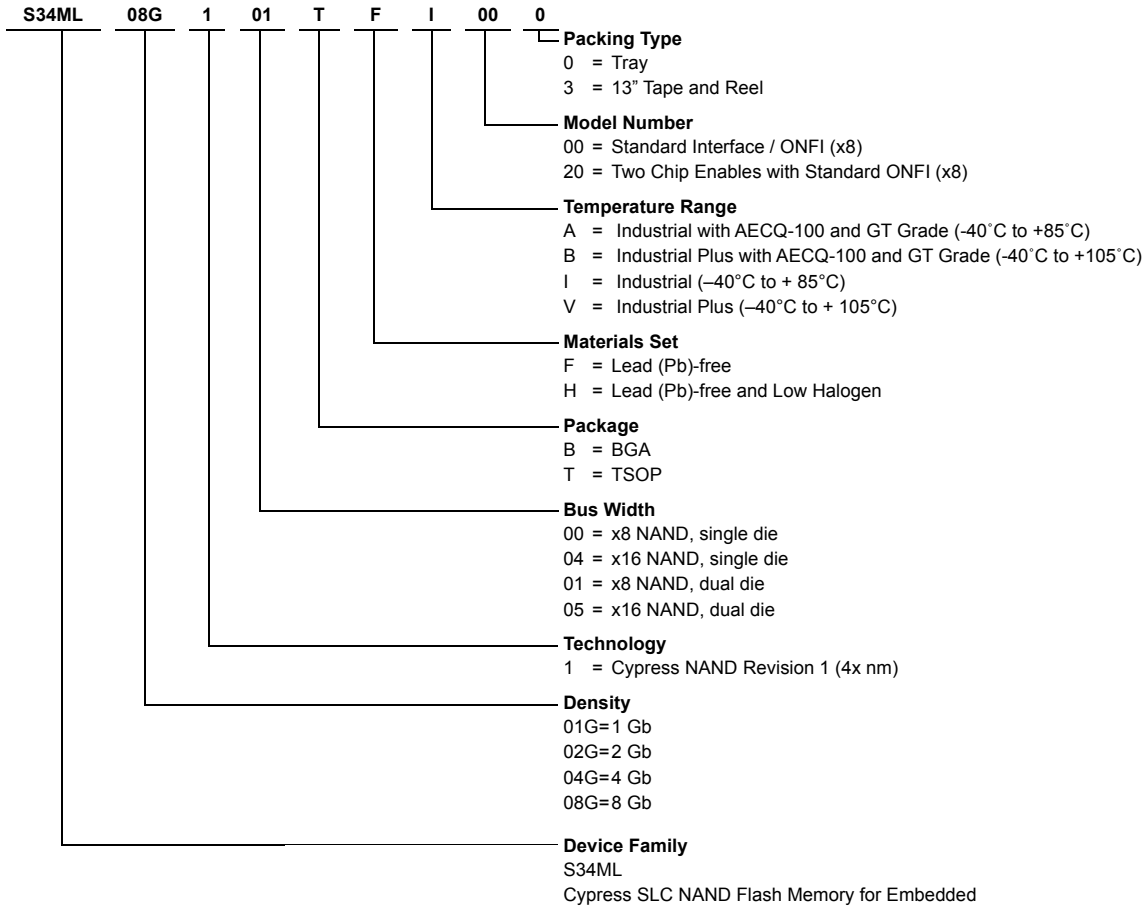

Valid Combinations

Valid Combinations list configurations planned to be supported in volume for this device. Consult your local sales office to confirm availability of specific valid combinations and to check on newly released combinations.

Valid Combinations								
Device Family	Density	Technology	Bus Width	Package Type	Temperature Range	Additional Ordering Options	Packing Type	Package Description
S34ML	08G	1	01	TF	A, B, I, V	00, 20	0, 3	TSOP
				BH		00		BGA (1)

Note:

1. BGA package marking omits the leading "S34" and the Packing Type designator from the ordering part number.

11. Appendix A — Errata

For Cypress NAND MCPs (Multi-Chip Package) like the 8 Gb (2 x 4 Gb), due to the internal bonding, READ ID automatically changes to the hard-wired values and currently there is no way to change it electrically. Therefore, the Cypress NAND 8 Gb with one CE# will not follow the same methodology of READ ID as SDPs (Single Die Package). The READ ID values for the 8-Gb Cypress NAND with one CE# will be as follows:

1st Byte: 01h

2nd Byte: D3h

3rd Byte: D1h

4th Byte: 95h

5th Byte: 58h

	1st Byte	2nd Byte	3rd Byte	4th Byte	5th Byte
8 Gb with one CE# (Currently with error)	01h	D3h	D1h	95h	58h
8 Gb with one CE# (Cypress methodology)	01h	DCh	91h	95h	54h

Currently, Cypress does not plan to fix the problem. If there are any issues related to this, please contact Cypress NAND Product Marketing for further questions.

12. Document History

Document Title: S34ML08G1, 8 Gb, 1-bit ECC, x8 I/O, 3 V, V _{CC} , NAND Flash Memory for Embedded				
Document Number: 002-00483				
Rev.	ECN No.	Orig. of Change	Submission Date	Description of Change
**	—	XILA	08/23/2012	Initial release
*A	—	XILA	10/1/2012	Addressing: Address Cycle Map table: corrected data Read ID: Read ID for Supported Configurations table: added row – 8 Gb (4 Gb x 2 – DDP with two CE#) Read Parameter Page: Parameter Page Description table corrected Electrical Parameters Block values for bytes 129-130 and bytes 131-132 corrected Vendor Block values for bytes 254-255 Appendix A: Added text
*B	—	XILA	11/29/2012	Ordering Information :Added Model Number
*C	—	XILA	12/19/2012	Read Parameter Page: Parameter Page Description table corrected Description for Bytes 129-130 and bytes 131-132 DC Characteristics: DC Characteristics and Operating Conditions table corrected Test Conditions for ICC1 Output High Voltage: removed IOH = 100 µA row Output Low Voltage: removed IOL = 100 µA row Output Low Current (R/B#): removed VOL = 0.1V row Ordering Information: Valid Combinations table: removed Bus Width 05
*D	—	XILA	08/09/2013	Distinctive Characteristics: Security - Removed Serial number (unique ID) Operating Temperature - removed Commercial and Extended temperatures Performance: Updated Reliability Connection Diagram: Added figure - 48-Pin TSOP1 Contact x8 Device (1 CE 8 Gb) Addressing: Address Cycle Map table - appended Note Added text to Bus Cycle column Extended Read Status: Extended Read Status table - removed Commands F4h and F5h Read Parameter Page: Parameter Page Description table - corrected Byte 44-63, 100, and 254-255 Values Valid Blocks: Valid Blocks table - clarified Device values DC Characteristics: DC Characteristics and Operating Conditions table - added row, 'V _{CC} Supply Voltage' Physical Interface: Updated figures TS2 48 — 48-lead Plastic Thin Small Outline, 12 x 20 mm, Package Outline VLD063 — 63-Pin BGA, 11 mm x 9 mm Package Ordering Information: Updated Materials Set: H = Low Halogen to H = Lead (Pb)-free and Low Halogen Valid Combinations table: removed 04G; Added Note
*E	—	XILA	04/01/2014	Ordering Information: Updated Temperature Range to include A (-40°C to 85°C GT Grade), B (-40°C to 105°C GT Grade), and V (-40°C to 105°C) Valid Combinations table - added A, B, V to Temperature Range
*F	—	XILA	01/14/2015	Global: Changed data sheet designation from <i>Advance Information</i> to <i>Full Production</i>

Document Title: S34ML08G1, 8 Gb, 1-bit ECC, x8 I/O, 3 V, V _{CC} , NAND Flash Memory for Embedded				
Document Number: 002-00483				
Rev.	ECN No.	Orig. of Change	Submission Date	Description of Change
*G	4953915	XILA	10/14/2015	Updated to Cypress template.
*H	5022236	XILA	11/20/2015	Updated General Description .
*I	5160512	XILA	04/25/2016	Added Recommended Operating Conditions section. Updated DC Characteristics section - updated "VCC supply Voltage (erase and program lockout)" to "Erase and Program Lockout voltage". Updated "Read Parameter Page" section. Updated "Ordering Information". Updated copyright information at the end of the document.
*J	5770454	AESATMP8	06/13/2017	Updated logo and Copyright.

Sales, Solutions, and Legal Information

Worldwide Sales and Design Support

Cypress maintains a worldwide network of offices, solution centers, manufacturer's representatives, and distributors. To find the office closest to you, visit us at [Cypress Locations](#).

Products

ARM® Cortex® Microcontrollers	cypress.com/arm
Automotive	cypress.com/automotive
Clocks & Buffers	cypress.com/clocks
Interface	cypress.com/interface
Internet of Things	cypress.com/iot
Memory	cypress.com/memory
Microcontrollers	cypress.com/mcu
PSoC	cypress.com/psoc
Power Management ICs	cypress.com/pmic
Touch Sensing	cypress.com/touch
USB Controllers	cypress.com/usb
Wireless Connectivity	cypress.com/wireless

PSoC® Solutions

[PSoC 1](#) | [PSoC 3](#) | [PSoC 4](#) | [PSoC 5LP](#) | [PSoC 6](#)

Cypress Developer Community

[Forums](#) | [WICED IOT Forums](#) | [Projects](#) | [Video](#) | [Blogs](#) | [Training](#) | [Components](#)

Technical Support

cypress.com/support

© Cypress Semiconductor Corporation, 2012-2017. This document is the property of Cypress Semiconductor Corporation and its subsidiaries, including Spansion LLC ("Cypress"). This document, including any software or firmware included or referenced in this document ("Software"), is owned by Cypress under the intellectual property laws and treaties of the United States and other countries worldwide. Cypress reserves all rights under such laws and treaties and does not, except as specifically stated in this paragraph, grant any license under its patents, copyrights, trademarks, or other intellectual property rights. If the Software is not accompanied by a license agreement and you do not otherwise have a written agreement with Cypress governing the use of the Software, then Cypress hereby grants you a personal, non-exclusive, nontransferable license (without the right to sublicense) (1) under its copyright rights in the Software (a) for Software provided in source code form, to modify and reproduce the Software solely for use with Cypress hardware products, only internally within your organization, and (b) to distribute the Software in binary code form externally to end users (either directly or indirectly through resellers and distributors), solely for use on Cypress hardware product units, and (2) under those claims of Cypress's patents that are infringed by the Software (as provided by Cypress, unmodified) to make, use, distribute, and import the Software solely for use with Cypress hardware products. Any other use, reproduction, modification, translation, or compilation of the Software is prohibited.

TO THE EXTENT PERMITTED BY APPLICABLE LAW, CYPRESS MAKES NO WARRANTY OF ANY KIND, EXPRESS OR IMPLIED, WITH REGARD TO THIS DOCUMENT OR ANY SOFTWARE OR ACCOMPANYING HARDWARE, INCLUDING, BUT NOT LIMITED TO, THE IMPLIED WARRANTIES OF MERCHANTABILITY AND FITNESS FOR A PARTICULAR PURPOSE. To the extent permitted by applicable law, Cypress reserves the right to make changes to this document without further notice. Cypress does not assume any liability arising out of the application or use of any product or circuit described in this document. Any information provided in this document, including any sample design information or programming code, is provided only for reference purposes. It is the responsibility of the user of this document to properly design, program, and test the functionality and safety of any application made of this information and any resulting product. Cypress products are not designed, intended, or authorized for use as critical components in systems designed or intended for the operation of weapons, weapons systems, nuclear installations, life-support devices or systems, other medical devices or systems (including resuscitation equipment and surgical implants), pollution control or hazardous substances management, or other uses where the failure of the device or system could cause personal injury, death, or property damage ("Unintended Uses"). A critical component is any component of a device or system whose failure to perform can be reasonably expected to cause the failure of the device or system, or to affect its safety or effectiveness. Cypress is not liable, in whole or in part, and you shall and hereby do release Cypress from any claim, damage, or other liability arising from or related to all Unintended Uses of Cypress products. You shall indemnify and hold Cypress harmless from and against all claims, costs, damages, and other liabilities, including claims for personal injury or death, arising from or related to any Unintended Uses of Cypress products.

Cypress, the Cypress logo, Spansion, the Spansion logo, and combinations thereof, WICED, PSoC, CapSense, EZ-USB, F-RAM, and Traveo are trademarks or registered trademarks of Cypress in the United States and other countries. For a more complete list of Cypress trademarks, visit cypress.com. Other names and brands may be claimed as property of their respective owners.