

SLLIMM™-nano (small low-loss intelligent molded module) IPM, 3 A - 600 V 3-phase IGBT inverter bridge

Datasheet - preliminary data

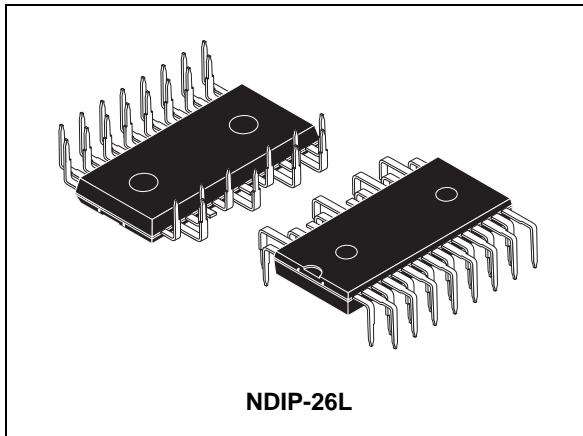

Features

- IPM 3 A, 600 V, 3-phase IGBT inverter bridge including control ICs for gate driving and freewheeling diodes
- Optimized for low electromagnetic interference
- $V_{CE(sat)}$ negative temperature coefficient
- 3.3 V, 5 V, 15 V CMOS/TTL inputs comparators with hysteresis and pull down/pull up resistors
- Undervoltage lockout
- Internal bootstrap diode
- Interlocking function
- Smart shutdown function
- Comparator for fault protection against overtemperature and overcurrent
- Op amp for advanced current sensing
- Optimized pin out for easy board layout

Applications

- 3-phase inverters for motor drives
- Dish washers, refrigerator compressors, heating systems, air-conditioning fans, draining and recirculation pumps

Description

This intelligent power module implements a compact, high performance AC motor drive in a simple, rugged design. It is composed of six IGBTs with freewheeling diodes and three half-bridge HVICs for gate driving, providing low electromagnetic interference (EMI) characteristics with optimized switching speed. The package is optimized for thermal performance and compactness in built-in motor applications, or other low power applications where assembly space is limited. This IPM includes an operational amplifier, completely uncommitted, and a comparator that can be used to design a fast and efficient protection circuit. SLLIMM™ is a trademark of STMicroelectronics.

Table 1. Device summary

Order code	Marking	Package	Packaging
STGIPN3H60-H	GIPN3H60-H	NDIP-26L	Tube

Contents

1	Internal schematic diagram and pin configuration	3
2	Electrical ratings	6
2.1	Absolute maximum ratings	6
2.2	Thermal data	7
3	Electrical characteristics	8
3.1	Control part	9
3.2	Waveform definitions	13
4	Smart shutdown function	14
5	Application information	16
5.1	Recommendations	17
6	Package mechanical data	18
7	Revision history	21

Table 2. Pin description

Pin	Symbol	Description
1	GND	Ground
2	\overline{SD} / OD	Shut down logic input (active low) / open drain (comparator output)
3	$V_{CC W}$	Low voltage power supply W phase
4	HIN W	High side logic input for W phase
5	LIN W	Low side logic input for W phase
6	OP+	Op amp non inverting input
7	OP _{OUT}	Op amp output
8	OP-	Op amp inverting input
9	$V_{CC V}$	Low voltage power supply V phase
10	HIN V	High side logic input for V phase
11	LIN V	Low side logic input for V phase
12	CIN	Comparator input
13	$V_{CC U}$	Low voltage power supply for U phase
14	HIN U	High side logic input for U phase
15	\overline{SD} / OD	Shut down logic input (active low) / open drain (comparator output)
16	LIN U	Low side logic input for U phase
17	$V_{BOOT U}$	Bootstrap voltage for U phase
18	P	Positive DC input
19	U, OUT _U	U phase output
20	N _U	Negative DC input for U phase
21	$V_{BOOT V}$	Bootstrap voltage for V phase
22	V, OUT _V	V phase output
23	N _V	Negative DC input for V phase
24	$V_{BOOT W}$	Bootstrap voltage for W phase
25	W, OUT _W	W phase output
26	N _W	Negative DC input for W phase

Figure 2. Pin layout (top view)

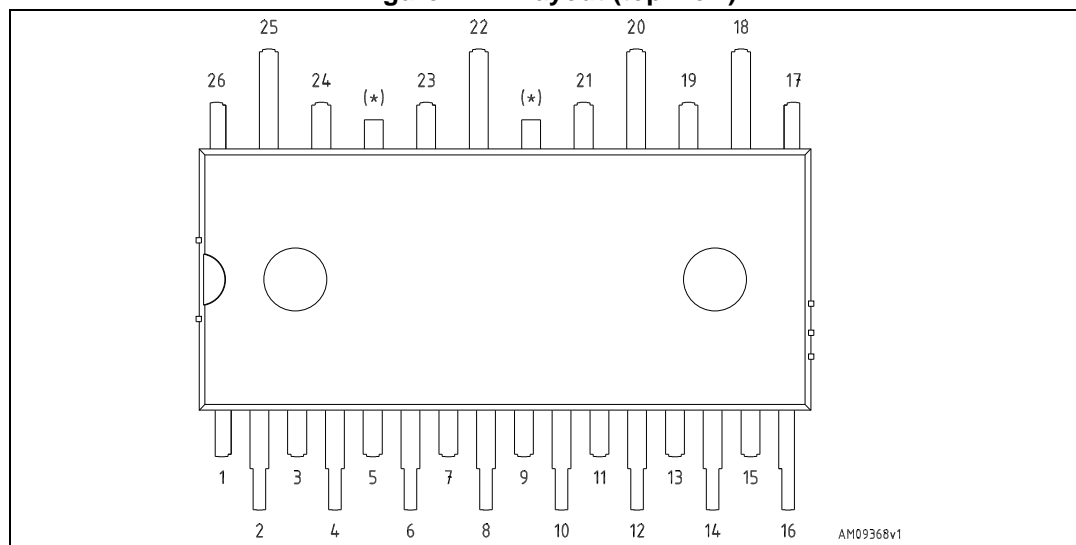

(*) Dummy pin internally connected to P (positive DC input).

2 Electrical ratings

2.1 Absolute maximum ratings

Table 3. Inverter part

Symbol	Parameter	Value	Unit
V_{CES}	Each IGBT collector emitter voltage ($V_{IN}^{(1)} = 0$)	600	V
$\pm I_C^{(2)}$	Each IGBT continuous collector current at $T_C = 25^\circ\text{C}$	3	A
$\pm I_{CP}^{(3)}$	Each IGBT pulsed collector current	18	A
P_{TOT}	Each IGBT total dissipation at $T_C = 25^\circ\text{C}$	8	W

1. Applied between HIN_i , LIN_i and GND for $i = U, V, W$
2. Calculated according to the iterative formula:

$$I_C(T_C) = \frac{T_{j(max)} - T_C}{R_{thj-c} \times V_{CE(sat)(max)}(T_{j(max)}, I_C(T_C))}$$

3. Pulse width limited by max junction temperature

Table 4. Control part

Symbol	Parameter	Min.	Max.	Unit
V_{OUT}	Output voltage applied between OUT_U , OUT_V , OUT_W - GND	$V_{boot} - 21$	$V_{boot} + 0.3$	V
V_{CC}	Low voltage power supply	- 0.3	21	V
V_{CIN}	Comparator input voltage	- 0.3	$V_{CC} + 0.3$	V
V_{op+}	OPAMP non-inverting input	- 0.3	$V_{CC} + 0.3$	V
V_{op-}	OPAMP inverting input	- 0.3	$V_{CC} + 0.3$	V
V_{boot}	Bootstrap voltage	- 0.3	620	V
V_{IN}	Logic input voltage applied between HIN , LIN and GND	- 0.3	15	V
$V_{SD/OD}$	Open drain voltage	- 0.3	15	V
$\Delta V_{OUT/dT}$	Allowed output slew rate		50	V/ns

Table 5. Total system

Symbol	Parameter	Value	Unit
V_{ISO}	Isolation withstand voltage applied between each pin and heatsink plate (AC voltage, $t = 60$ sec.)	1000	V
T_j	Power chips operating junction temperature	-40 to 150	$^\circ\text{C}$
T_C	Module case operation temperature	-40 to 125	$^\circ\text{C}$

2.2 Thermal data

Table 6. Thermal data

Symbol	Parameter	Value	Unit
R_{thJA}	Thermal resistance junction-ambient	50	°C/W

3 Electrical characteristics

$T_J = 25\text{ }^\circ\text{C}$ unless otherwise specified.

Table 7. Inverter part

Symbol	Parameter	Test conditions	Min.	Typ.	Max.	Unit
$V_{CE(sat)}$	Collector-emitter saturation voltage	$V_{CC} = V_{boot} = 15\text{ V}$, $V_{IN}^{(1)} = 0 - 5\text{ V}$, $I_C = 1\text{ A}$	-	2.15	2.6	V
		$V_{CC} = V_{boot} = 15\text{ V}$, $V_{IN}^{(1)} = 0 - 5\text{ V}$, $I_C = 1\text{ A}$, $T_J = 125\text{ }^\circ\text{C}$	-	1.65		
I_{CES}	Collector-cut off current ($V_{IN}^{(1)} = 0$ "logic state")	$V_{CE} = 550\text{ V}$, $V_{CC} = V_{Boot} = 15\text{ V}$	-		250	μA
V_F	Diode forward voltage	$V_{IN}^{(1)} = 0$ "logic state", $I_C = 1\text{ A}$	-		1.7	V
Inductive load switching time and energy						
t_{on}	Turn-on time	$V_{DD} = 300\text{ V}$, $V_{CC} = V_{boot} = 15\text{ V}$, $V_{IN}^{(1)} = 0 - 5\text{ V}$, $I_C = 1\text{ A}$ (see Figure 4)	-	275		ns
$t_{c(on)}$	Crossover time (on)		-	90		
t_{off}	Turn-off time		-	890		
$t_{c(off)}$	Crossover time (off)		-	125		
t_{rr}	Reverse recovery time		-	50		
E_{on}	Turn-on switching losses		-	18		μJ
E_{off}	Turn-off switching losses		-	13		

1. Applied between HIN_i , LIN_i and GND for $i = U, V, W$.

Note: t_{ON} and t_{OFF} include the propagation delay time of the internal drive. $t_{C(ON)}$ and $t_{C(OFF)}$ are the switching time of IGBT itself under the internally given gate driving condition.

Figure 3. Switching time test circuit

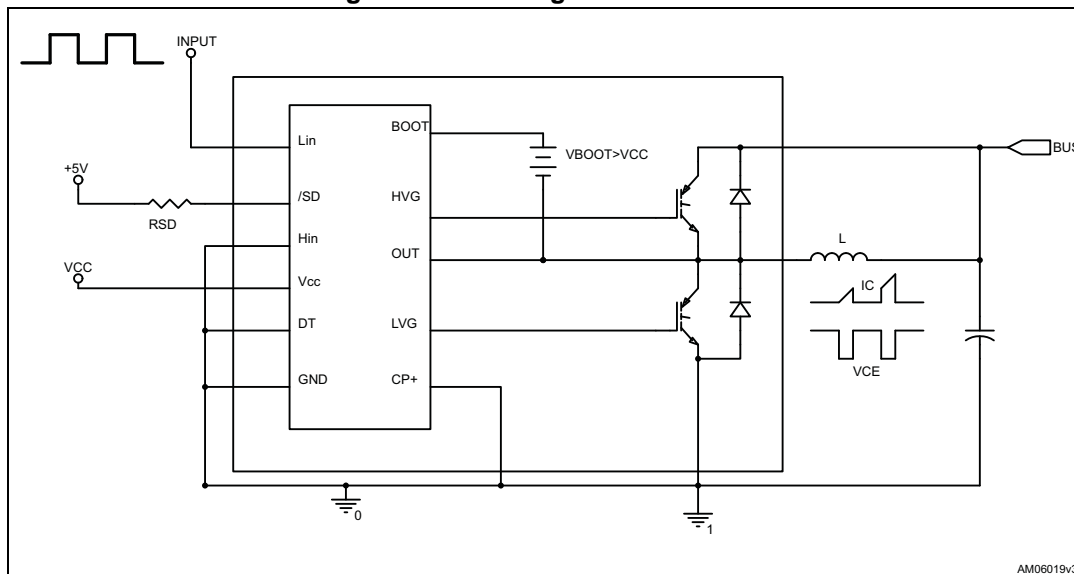

AM06019v3

Figure 4. Switching time definition

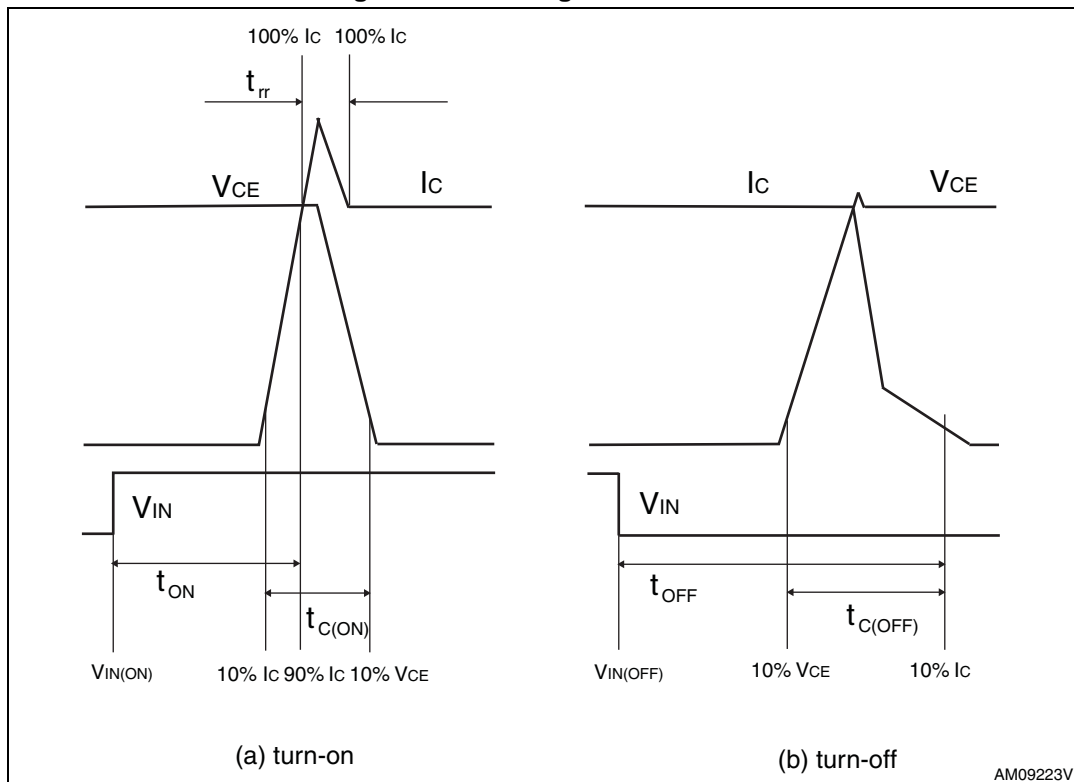

Note: Figure 4 “Switching time definition” refers to HIN, LIN inputs (active high).

3.1 Control part

Table 8. Low voltage power supply (VCC = 15 V unless otherwise specified)

Symbol	Parameter	Test conditions	Min.	Typ.	Max.	Unit
V _{CC_hys}	V _{CC} UV hysteresis		1.2	1.5	1.8	V
V _{CC_thON}	V _{CC} UV turn ON threshold		11.5	12	12.5	V
V _{CC_thOFF}	V _{CC} UV turn OFF threshold		10	10.5	11	V
I _{qccu}	Undervoltage quiescent supply current	V _{CC} = 10 V SD/OD = 5 V; LIN = 0; H _{IN} = 0, C _{IN} = 0			150	μA
I _{qcc}	Quiescent current	V _{CC} = 15 V SD/OD = 5 V; LIN = 0; H _{IN} = 0, C _{IN} = 0			1	mA
V _{ref}	Internal comparator (CIN) reference voltage		0.5	0.54	0.58	V

Table 9. Bootstrapped voltage ($V_{CC} = 15\text{ V}$ unless otherwise specified)

Symbol	Parameter	Test conditions	Min.	Typ.	Max.	Unit
V_{BS_hys}	V_{BS} UV hysteresis		1.2	1.5	1.8	V
V_{BS_thON}	V_{BS} UV turn ON threshold		11.1	11.5	12.1	V
V_{BS_thOFF}	V_{BS} UV turn OFF threshold		9.8	10	10.6	V
I_{QBSU}	Undervoltage V_{BS} quiescent current	$V_{BS} < 9\text{ V}$ $\overline{SD}/OD = 5\text{ V}; LIN = 0$ $HIN = 5\text{ V}; C_{IN} = 0$		70	110	μA
I_{QBS}	V_{BS} quiescent current	$V_{BS} = 15\text{ V}$ $\overline{SD}/OD = 5\text{ V}; LIN = 0$ $HIN = 5\text{ V}; C_{IN} = 0$		200	300	μA
$R_{DS(on)}$	Bootstrap driver on resistance	LVG ON		120		Ω

Table 10. Logic inputs ($V_{CC} = 15\text{ V}$ unless otherwise specified)

Symbol	Parameter	Test conditions	Min.	Typ.	Max.	Unit
V_{il}	Low logic level voltage		0.8		1.1	V
V_{ih}	High logic level voltage		1.9		2.25	V
I_{HINh}	HIN logic "1" input bias current	$HIN = 15\text{ V}$	20	40	100	μA
I_{HINl}	HIN logic "0" input bias current	$HIN = 0\text{ V}$			1	μA
I_{LINh}	LIN logic "1" input bias current	$LIN = 15\text{ V}$	20	40	100	μA
I_{LINl}	LIN logic "0" input bias current	$LIN = 0\text{ V}$			1	μA
I_{SDh}	\overline{SD} logic "0" input bias current	$\overline{SD} = 15\text{ V}$	30	120	300	μA
I_{SDl}	\overline{SD} logic "1" input bias current	$\overline{SD} = 0\text{ V}$			3	μA
Dt	Dead time	see Figure 5		180		ns

Table 11. OPAMP characteristics ($V_{CC} = 15\text{ V}$ unless otherwise specified)

Symbol	Parameter	Test condition	Min.	Typ.	Max.	Unit
V_{io}	Input offset voltage	$V_{ic} = 0\text{ V}$, $V_o = 7.5\text{ V}$			6	mV
I_{io}	Input offset current	$V_{ic} = 0\text{ V}$, $V_o = 7.5\text{ V}$		4	40	nA
I_{ib}	Input bias current ⁽¹⁾			100	200	nA
V_{icm}	Input common mode voltage range		0			V
V_{OL}	Low level output voltage	$R_L = 10\text{ k}\Omega$ to V_{CC}		75	150	mV
V_{OH}	High level output voltage	$R_L = 10\text{ k}\Omega$ to GND	14	14.7		V
I_o	Output short circuit current	Source, $V_{id} = +1$; $V_o = 0\text{ V}$	16	30		mA
		Sink, $V_{id} = -1$; $V_o = V_{CC}$	50	80		mA
SR	Slew rate	$V_i = 1 - 4\text{ V}$; $C_L = 100\text{ pF}$; unity gain	2.5	3.8		V/ μs
GBWP	Gain bandwidth product	$V_o = 7.5\text{ V}$	8	12		MHz
A_{vd}	Large signal voltage gain	$R_L = 2\text{ k}\Omega$	70	85		dB
SVR	Supply voltage rejection ratio	vs. V_{CC}	60	75		dB
CMRR	Common mode rejection ratio		55	70		dB

1. The direction of input current is out of the IC.

Table 12. Sense comparator characteristics ($V_{CC} = 15\text{ V}$ unless otherwise specified)

Symbol	Parameter	Test conditions	Min.	Typ.	Max.	Unit
I_{ib}	Input bias current	$V_{CIN} = 1\text{ V}$			3	μA
V_{ol}	Open drain low level output voltage	$I_{od} = 3\text{ mA}$			0.5	V
t_{d_comp}	Comparator delay	\overline{SD}/OD pulled to 5 V through 100 k Ω resistor		90	130	ns
SR	Slew rate	$C_L = 180\text{ pF}$; $R_{pu} = 5\text{ k}\Omega$		60		V/ μsec
t_{sd}	Shutdown to high / low side driver propagation delay	$V_{OUT} = 0$, $V_{boot} = V_{CC}$, $V_{IN} = 0$ to 3.3 V	50	125	200	ns
t_{isd}	Comparator triggering to high / low side driver turn-off propagation delay	Measured applying a voltage step from 0 V to 3.3 V to pin CIN	50	200	250	

Table 13. Truth table

Condition	Logic input (V _I)			Output	
	$\overline{\text{SD/OD}}$	LIN	HIN	LVG	HVG
Shutdown enable half-bridge tri-state	L	X	X	L	L
Interlocking half-bridge tri-state	H	H	H	L	L
0 "logic state" half-bridge tri-state	H	L	L	L	L
1 "logic state" low side direct driving	H	H	L	H	L
1 "logic state" high side direct driving	H	L	H	L	H

Note: X: don't care

3.2 Waveform definitions

Figure 5. Dead time and interlocking waveform definitions

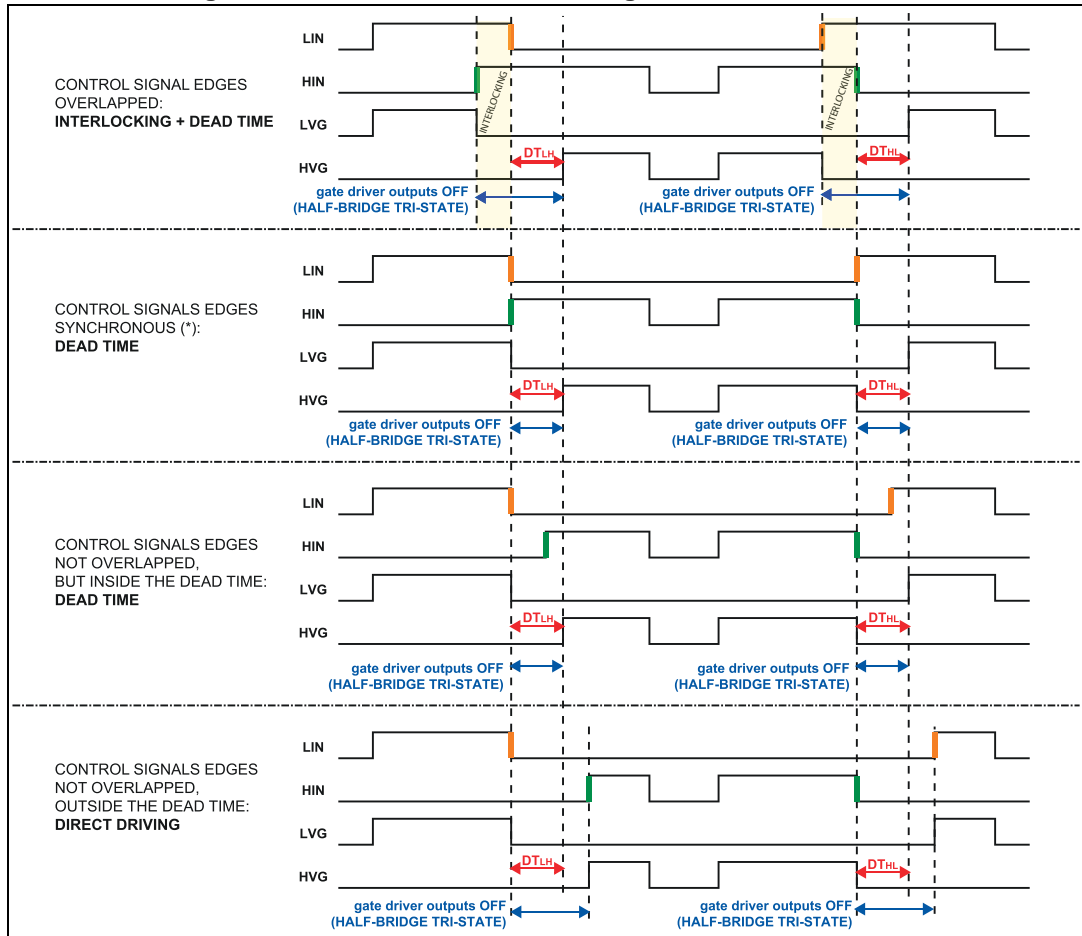

4 Smart shutdown function

The STGIPN3H60-H integrates a comparator for fault sensing purposes. The comparator has an internal voltage reference V_{REF} connected to the inverting input, while the non-inverting input, available on pin (CIN), can be connected to an external shunt resistor in order to implement a simple over-current protection function. When the comparator triggers, the device is set in shutdown state and both its outputs are set to low-level leading the halfbridge in tri-state. In the common overcurrent protection architectures the comparator output is usually connected to the shutdown input through a RC network, in order to provide a mono-stable circuit, which implements a protection time that follows the fault condition. Our smart shutdown architecture allows to immediately turn-off the output gate driver in case of overcurrent, the fault signal has a preferential path which directly switches off the outputs. The time delay between the fault and the outputs turn-off is no more dependent on the RC values of the external network connected to the shutdown pin. At the same time the DMOS connected to the open-drain output is turned on by the internal logic which holds it on until the shutdown voltage is lower than the logic input lower threshold (V_{il}). Finally, the smart shutdown function provides the possibility to increase the real disable time without increasing the constant time of the external RC network.

Figure 6. Smart shutdown timing waveforms

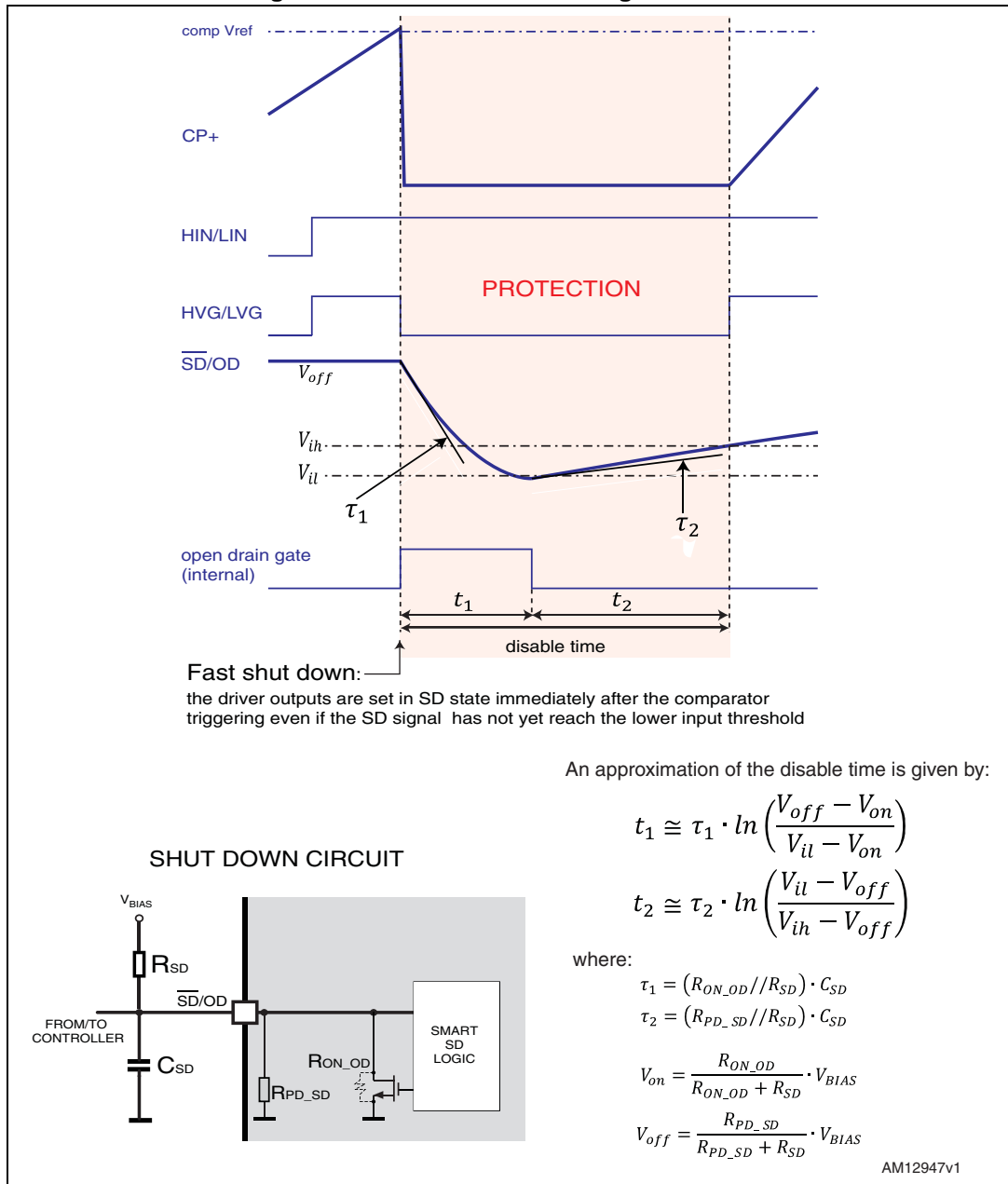

Please refer to [Table 12](#) for internal propagation delay time details.

5.1 Recommendations

- Input signals HIN, LIN are active high logic. A 375 k Ω (typ.) pull down resistor is built-in for each input. If an external RC filter is used, for noise immunity, pay attention to the variation of the input signal level.
- To prevent input signal oscillation, the wiring of each input should be as short as possible.
- By integrating an application-specific type HVIC inside the module, direct coupling to the MCU terminals without an opto-coupler is possible.
- Each capacitor should be located as close as possible to the pins of the IPM.
- Low inductance shunt resistors should be used for phase leg current sensing.
- Electrolytic bus capacitors should be mounted as close to the module bus terminals as possible. Additional high frequency ceramic capacitors mounted close to the module pins will further improve performance.
- The $\overline{\text{SD/OD}}$ signal should be pulled up to 5 V / 3.3 V with an external resistor (see [Section 4: Smart shutdown function](#) for detailed info).

Table 14. Recommended operating conditions

Symbol	Parameter	Test conditions	Min.	Typ.	Max.	Unit
V_{PN}	Supply voltage	Applied between P-Nu, Nv, Nw		300	500	V
V_{CC}	Control supply voltage	Applied between V_{CC} -GND	13.5	15	18	V
V_{BS}	High side bias voltage	Applied between V_{BOOTi} - OUT_i for $i = U, V, W$	13		18	V
t_{dead}	Blanking time to prevent Arm-short	For each input signal	1.5			μs
f_{PWM}	PWM input signal	-40°C < T_c < 100°C -40°C < T_j < 125°C			25	kHz
T_c	Case operation temperature				100	°C

Note: For further details refer to AN4043.

6 Package mechanical data

In order to meet environmental requirements, ST offers these devices in different grades of ECOPACK® packages, depending on their level of environmental compliance. ECOPACK® specifications, grade definitions and product status are available at: www.st.com. ECOPACK® is an ST trademark.

Figure 8. NDIP-26L drawing

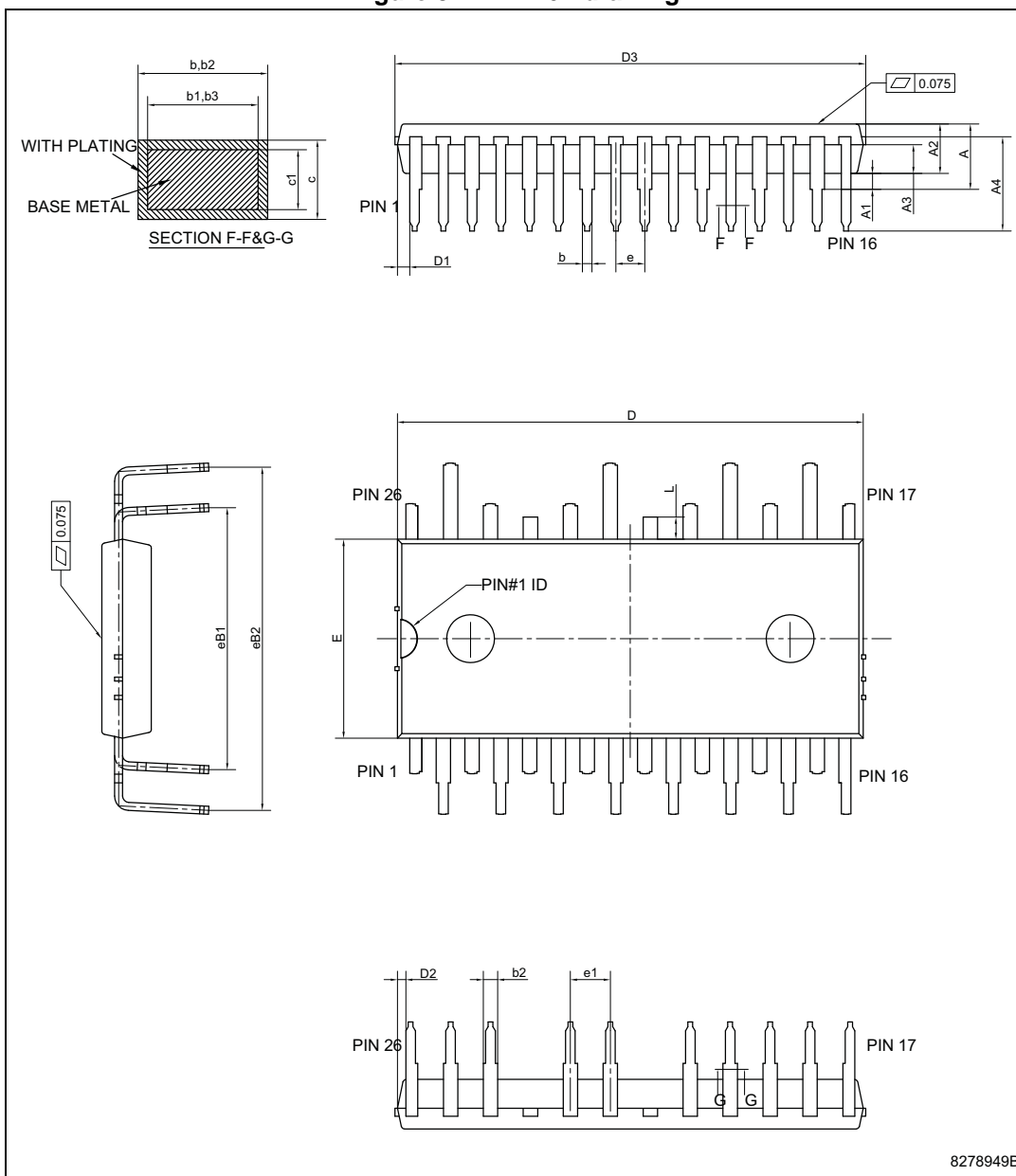
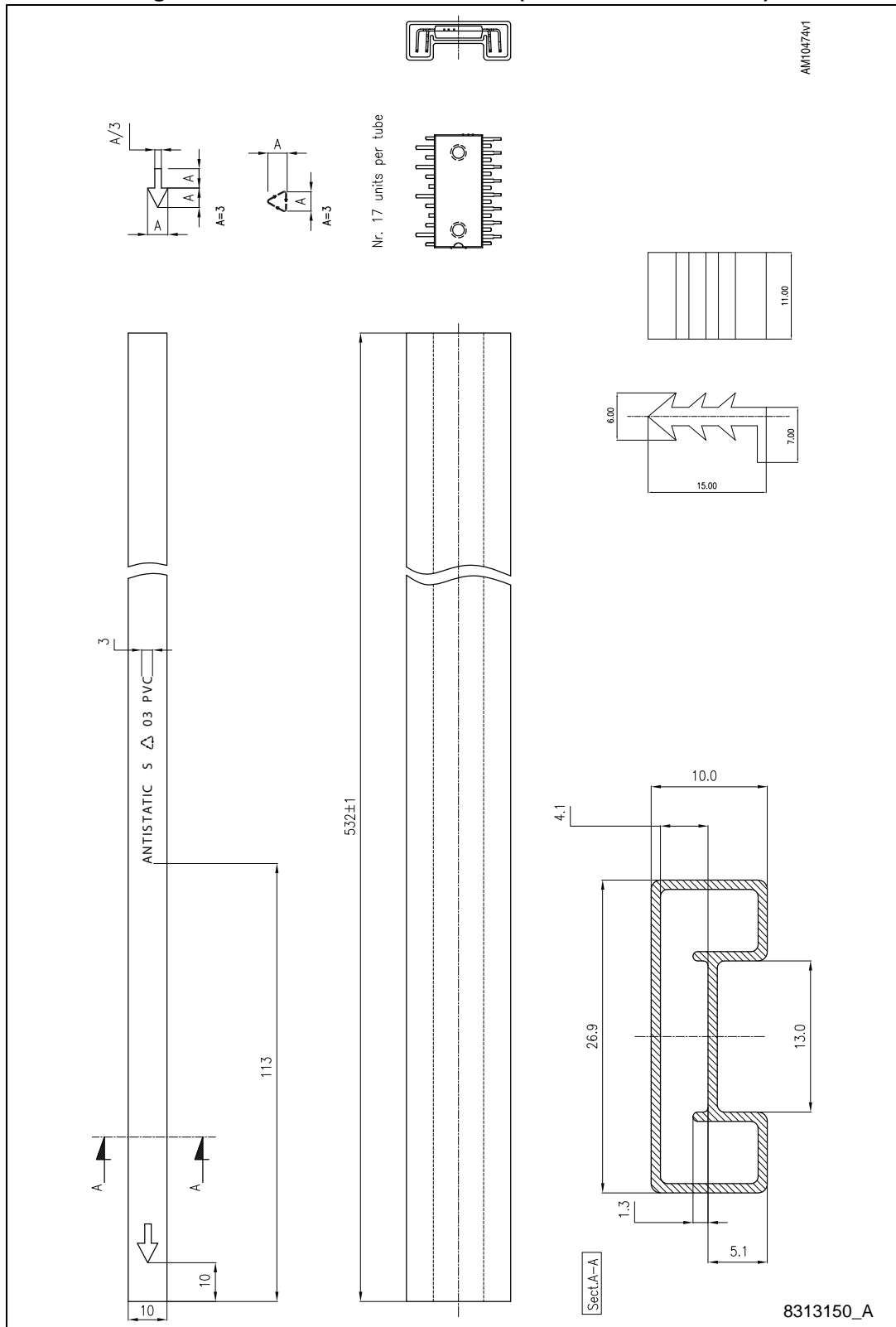

Table 15. NDIP-26L mechanical data

Dim.	mm.		
	Min.	Typ.	Max.
A			4.40
A1	0.80	1.00	1.20
A2	3.00	3.10	3.20
A3	1.70	1.80	1.90
A4	5.70	5.90	6.10
b	0.53		0.72
b1	0.52	0.60	0.68
b2	0.83		1.02
b3	0.82	0.90	0.98
c	0.46		0.59
c1	0.45	0.50	0.55
D	29.05	29.15	29.25
D1	0.50	0.77	1.00
D2	0.35	0.53	0.70
D3			29.55
E	12.35	12.45	12.55
e	1.70	1.80	1.90
e1	2.40	2.50	2.60
eB1	16.10	16.40	16.70
eB2	21.18	21.48	21.78
L	1.24	1.39	1.54

Figure 9. NDIP-26L tube dimensions (dimensions are in mm.)



Note: Base quantity 17 pcs, bulk quantity 476 pcs.

7 Revision history

Table 16. Document revision history

Date	Revision	Changes
15-Jan-2013	1	Initial release.
02-May-2013	2	Modified: <i>Figure 3 on page 8, Section 4 on page 14 and Figure 6 on page 15.</i>
14-Mar-2014	3	Updated <i>Figure 3: Switching time test circuit, Table 9: Bootstrapped voltage (VCC = 15 V unless otherwise specified) and Table 10: Logic inputs (VCC = 15 V unless otherwise specified).</i> Updated <i>Section 6: Package mechanical data.</i>

Please Read Carefully:

Information in this document is provided solely in connection with ST products. STMicroelectronics NV and its subsidiaries ("ST") reserve the right to make changes, corrections, modifications or improvements, to this document, and the products and services described herein at any time, without notice.

All ST products are sold pursuant to ST's terms and conditions of sale.

Purchasers are solely responsible for the choice, selection and use of the ST products and services described herein, and ST assumes no liability whatsoever relating to the choice, selection or use of the ST products and services described herein.

No license, express or implied, by estoppel or otherwise, to any intellectual property rights is granted under this document. If any part of this document refers to any third party products or services it shall not be deemed a license grant by ST for the use of such third party products or services, or any intellectual property contained therein or considered as a warranty covering the use in any manner whatsoever of such third party products or services or any intellectual property contained therein.

UNLESS OTHERWISE SET FORTH IN ST'S TERMS AND CONDITIONS OF SALE ST DISCLAIMS ANY EXPRESS OR IMPLIED WARRANTY WITH RESPECT TO THE USE AND/OR SALE OF ST PRODUCTS INCLUDING WITHOUT LIMITATION IMPLIED WARRANTIES OF MERCHANTABILITY, FITNESS FOR A PARTICULAR PURPOSE (AND THEIR EQUIVALENTS UNDER THE LAWS OF ANY JURISDICTION), OR INFRINGEMENT OF ANY PATENT, COPYRIGHT OR OTHER INTELLECTUAL PROPERTY RIGHT.

ST PRODUCTS ARE NOT DESIGNED OR AUTHORIZED FOR USE IN: (A) SAFETY CRITICAL APPLICATIONS SUCH AS LIFE SUPPORTING, ACTIVE IMPLANTED DEVICES OR SYSTEMS WITH PRODUCT FUNCTIONAL SAFETY REQUIREMENTS; (B) AERONAUTIC APPLICATIONS; (C) AUTOMOTIVE APPLICATIONS OR ENVIRONMENTS, AND/OR (D) AEROSPACE APPLICATIONS OR ENVIRONMENTS. WHERE ST PRODUCTS ARE NOT DESIGNED FOR SUCH USE, THE PURCHASER SHALL USE PRODUCTS AT PURCHASER'S SOLE RISK, EVEN IF ST HAS BEEN INFORMED IN WRITING OF SUCH USAGE, UNLESS A PRODUCT IS EXPRESSLY DESIGNATED BY ST AS BEING INTENDED FOR "AUTOMOTIVE, AUTOMOTIVE SAFETY OR MEDICAL" INDUSTRY DOMAINS ACCORDING TO ST PRODUCT DESIGN SPECIFICATIONS. PRODUCTS FORMALLY ESCC, QML OR JAN QUALIFIED ARE DEEMED SUITABLE FOR USE IN AEROSPACE BY THE CORRESPONDING GOVERNMENTAL AGENCY.

Resale of ST products with provisions different from the statements and/or technical features set forth in this document shall immediately void any warranty granted by ST for the ST product or service described herein and shall not create or extend in any manner whatsoever, any liability of ST.

ST and the ST logo are trademarks or registered trademarks of ST in various countries.

Information in this document supersedes and replaces all information previously supplied.

The ST logo is a registered trademark of STMicroelectronics. All other names are the property of their respective owners.

© 2014 STMicroelectronics - All rights reserved

STMicroelectronics group of companies

Australia - Belgium - Brazil - Canada - China - Czech Republic - Finland - France - Germany - Hong Kong - India - Israel - Italy - Japan - Malaysia - Malta - Morocco - Philippines - Singapore - Spain - Sweden - Switzerland - United Kingdom - United States of America

www.st.com