

NOTES:

1. MATERIAL: PA66、BRASS、SILICONE;
2. CERTIFICATION: ROHS/TUV/SAA/CE;
3. FIRE-PROOF: UL94-V2.
4. NO DEFECT IN APPEARANCE;
5. UNITS: mm;
6. CONDUCTION TEST: THE TWO ENDS OF THE 3 CORE JOINTS ARE RESPECTIVELY CONNECTED
7. A、 MAXIMUM CURRENT-CARRYING CAPACITY: 400V/16A
B、 TEST VOLTAGE: 2500V
C、 SUITABLE FOR CABLES CROSS SECTIONS: 0.5-2.5mm²
D、 OPERATING TEMPERATURE RANGE: -40~+105°C
E、 PROTECTION CLASS: IP68



3 Pins



Silicone parts

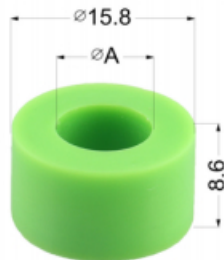

$\varnothing B$	Wire OD
$\varnothing 11.5$	$\varnothing 9-12\text{mm}$
$\varnothing 8.5$	$\varnothing 5-9\text{mm}$

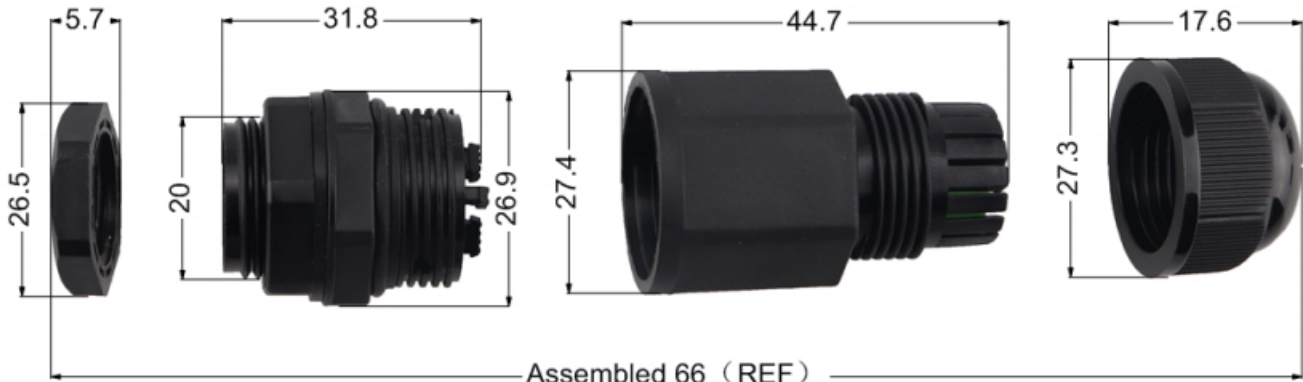

T03