

LMK0482x Ultra Low-Noise JESD204B Compliant Clock Jitter Cleaner with Dual Loop PLLs

1 Features

- JEDEC JESD204B Support
- Ultra-Low RMS Jitter
 - 88 fs RMS Jitter (12 kHz to 20 MHz)
 - 91 fs RMS Jitter (100 Hz to 20 MHz)
 - -162.5 dBc/Hz Noise Floor at 245.76 MHz
- Up to 14 Differential Device Clocks from PLL2
 - Up to 7 SYSREF Clocks
 - Maximum Clock Output Frequency 3.1 GHz
 - LVPECL, LVDS, HSDS, LCPECL Programmable Outputs from PLL2
- Up to 1 Buffered VCXO/Crystal Output from PLL1
 - LVPECL, LVDS, 2xLVCMOS Programmable
- Dual Loop PLLatinum™ PLL Architecture
- PLL1
 - Up to 3 Redundant Input Clocks
 - Automatic and Manual Switch-Over Modes
 - Hitless Switching and LOS
 - Integrated Low-Noise Crystal Oscillator Circuit
 - Holdover mode when Input Clocks are Lost
- PLL2
 - Normalized [1 Hz] PLL Noise Floor of -227 dBc/Hz
 - Phase Detector Rate up to 155 MHz
 - OSCin Frequency-Doubler
 - Two Integrated Low-Noise VCOs
- 50% Duty Cycle Output Divides, 1 to 32 (even and odd)
- Precision Digital Delay, Dynamically Adjustable
- 25 ps Step Analog Delay
- Multi-mode: Dual PLL, single PLL, and Clock Distribution
- Industrial Temperature Range: -40 to 85°C
- Supports 105°C PCB Temperature (Measured at Thermal Pad)
- 3.15-V to 3.45-V Operation
- Package: 64-Pin QFN (9.0 mm x 9.0 mm x 0.8 mm)

2 Applications

- Wireless Infrastructure
- Data Converter Clocking
- Networking, SONET/SDH, DSLAM
- Medical / Video / Military / Aerospace
- Test and Measurement

3 Description

The LMK0482x family is the industry's highest performance clock conditioner with JEDEC JESD204B support.

The 14 clock outputs from PLL2 can be configured to drive seven JESD204B converters or other logic devices using device and SYSREF clocks. SYSREF can be provided using both DC and AC coupling. Not limited to JESD204B applications, each of the 14 outputs can be individually configured as high performance outputs for traditional clocking systems.

The high performance combined with features like the ability to trade off between power or performance, dual VCOs, dynamic digital delay, holdover, and glitchless analog delay make the LMK0482x family ideal for providing flexible high performance clocking trees.

Device Information⁽¹⁾

PART NUMBER	VCO0 FREQUENCY	VCO1 FREQUENCY
LMK04821	1930 to 2075 MHz	2920 to 3080 MHz VCO1 Div = ÷2 to ÷8 (÷2 = 1460 to 1540 MHz)
LMK04826B	1840 to 1970 MHz	2440 to 2505 MHz
LMK04828B	2370 to 2630 MHz	2920 to 3080 MHz

(1) For all available packages, see the orderable addendum at the end of the datasheet.

Simplified Schematic

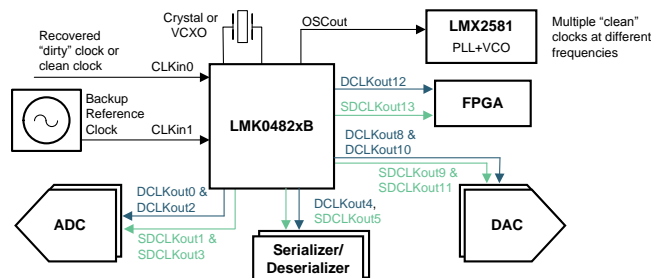

Table of Contents

1 Features	1	9.3 Feature Description.....	36
2 Applications	1	9.4 Device Functional Modes.....	46
3 Description	1	9.5 Programming.....	49
4 Revision History	2	9.6 Register Maps	50
5 Device Comparison Table	6	9.7 Device Register Descriptions.....	54
5.1 Device Configuration Information.....	6	10 Applications and Implementation	95
6 Pin Configuration and Functions	7	10.1 Application Information.....	95
7 Specifications	9	10.2 Typical Applications	95
7.1 Absolute Maximum Ratings	9	10.3 Do's and Don'ts.....	101
7.2 ESD Ratings.....	9	11 Power Supply Recommendations	102
7.3 Recommended Operating Conditions.....	9	11.1 Current Consumption / Power Dissipation	
7.4 Thermal Information	9	Calculations.....	102
7.5 Electrical Characteristics.....	10	12 Layout	103
7.6 SPI Interface Timing	23	12.1 Layout Guidelines	103
7.7 Typical Characteristics – Clock Output AC		12.2 Layout Example	104
Characteristics	24	13 Device and Documentation Support	105
8 Parameter Measurement Information	26	13.1 Device Support	105
8.1 Charge Pump Current Specification Definitions.....	26	13.2 Related Links	105
8.2 Differential Voltage Measurement Terminology	27	13.3 Trademarks	105
9 Detailed Description	28	13.4 Electrostatic Discharge Caution.....	105
9.1 Overview	28	13.5 Glossary	105
9.2 Functional Block Diagram	32	14 Mechanical, Packaging, and Orderable	
		Information	105

4 Revision History

Changes from Revision AQ (August 2014) to Revision AR	Page
• Added Support for 105°C thermal pad temperature	1
• Changed from I/O to I for pin 6 in <i>Pin Functions</i> table	7
• Deleted <i>programmable status pin</i> in Description column for pin 6 in <i>Pin Functions</i> table.....	7
• Changed from <i>No connection</i> to <i>Do not connect</i> for pins 7, 8, 9 in <i>Pin Functions</i> table	7
• Changed to <i>Reference Clk Input Port 1 for PLL 1</i> for Pins 34, 35 in <i>Pin Functions</i>	8
• Added <i>Reference Clock Input Port 2 for PLL1</i> for pins 40, 41 in <i>Pin Functions</i>	8
• Added ESD Ratings	9
• Added PCB temperature in <i>Recommended Operating Conditions</i>	9
• Added <i>Digital Input Timing</i> in <i>Electrical Characteristics</i>	22
• Changed Detailed block diagrams for LMK04821 and LMK04826/8	32
• Added 6 to DCLKout0 sequence and 7 to SDCLKout1 sequence in Figure 12	34
• Added 6 to DCLKout0 sequence and 7 to SDCLKout1 sequence in Figure 13	35
• Added <i>For each SDCLKoutY being used</i> in SYNC/SYSREF	36
• Deleted "SDCLKoutY_PD as required per output. " in Table 1	36
• Added footnote starting <i>SDCLKoutY_PD = 0</i> as... in Table 1	36
• Added <i>SDCLKout1_PD = 0, SDCLKout3_PD = 0</i> in Setup of SYSREF Example	37
• Changed DLD_HOLD_CNT to HOLDOVER_DLD_CNT in <i>Holdover Mode - Automatic Exit of Holdover</i>	45
• Changed <i>Recommended Programming Sequence</i>	49
• Added 0x171/0x172 to Register Map	53
• Added LMK04821 register setting	55
• Revised Register 0x143 table.....	67
• Added fixed register setting for 0x171.....	68

Revision History (continued)

• Added fixed register setting for 0x172	68
• Added LMK04821 register setting	91
• Added LMK04821 register setting	92
• Changed RB_PLL1_LD description	92
• Changed RB_PLL2_LD description	92

Changes from Revision AP (June 2013) to Revision AQ
Page

• Changed data sheet flow and layout to conform with new TI standards. Added, updated, or renamed the following sections: Device Information Table, Application and Implementation; Power Supply Recommendations; Layout; Device and Documentation Support; Mechanical, Packaging, and Ordering Information	1
• Added values for LMK04821 under "Features" section.	1
• Changed LMK04820 family to LMK0482x family	1
• Added values for LMK04821 in <i>Device Configuration Information</i>	6
• Added <i>holdover DAC</i> to pin 36 description in <i>Pin Functions</i>	8
• Changed <i>Thermal Information</i> header from LMK0482xB to LMK0482x	9
• Changed <i>CLKinX_BUF_TYPE</i> to <i>CLKinX_TYPE</i> in <i>Electrical Characteristics</i>	10
• Added values for LMK04821 under <i>Internal VCO Specifications</i> in <i>Electrical Characteristics</i>	13
• Added values for LMK04821 under <i>Noise Floor</i> in <i>Electrical Characteristics</i>	14
• Added values for LMK04821 under <i>CLKout Closed Loop Phase Noise Specifications a Commercial Quality VCXO</i> in <i>Electrical Characteristics</i>	15
• Added 245.76 MHz as frequency for LMK04826B phase noise data $L(f)_{CLKout}$ for VCO0	16
• Added 245.76 MHz as frequency for LMK04826B phase noise data $L(f)_{CLKout}$ for VCO1	16
• Added 245.76 MHz as frequency for LMK04828B phase noise data $L(f)_{CLKout}$ for VCO0	16
• Added 245.76 MHz as frequency for LMK04828B phase noise data $L(f)_{CLKout}$ for VCO1	16
• Added values for LMK04821 under <i>CLKout Closed Loop Jitter Specifications a Commercial Quality VCXO</i>	17
• Added $SDCLKoutY_HS = 0$ for $t_{JESD204B}$ in Electrical Characteristics	19
• Added <i>Propagation Delay from CLKin0 to SDCLKoutY</i> in Electrical Characteristics	19
• Added footnote that LMK04821 has no DCLKoutX or SDCLKoutY outputs on at power up, only OSCout.	19
• Changed V_{OH} TEST CONDITIONS to = 3 or 4 and V_{OL} TEST CONDITIONS to 3, 4, or 6 under DIGITAL OUTPUTS (CLKin_SELX, Status_LDX, and RESET/GPO) subheading in Electrical Characteristics	21
• Changed Digital Inputs (SCK, SDIO, CS*) I_{IH} $V_{IH} = V_{CC}$ min line from 5 μ A to -5 μ A.....	22
• Added <i>4 wire mode read back has same timing as SDIO pin, R/W bit = 0 is for SPI write, R/W bit = 1 is for SPI read, W1 and W0 shall be written as 0.</i>	23
• Added LMK04821 phase noise graphs under <i>Clock Output AC Characteristics</i>	24
• Added link to AN-912 Application Report	27
• Changed from <i>Glitchless Half Shift</i> to <i>Glitchless Half Step</i>	30
• Added LMK04821 detailed block diagram.....	32
• Changed block from SDCLKoutY_POL to DCLKoutX_POL in Figure 12	34
• Added SYSREF_CLKin0_MUX block to Figure 13 image.	35
• Changed Figure 13 to show that FB_MUX SYSREF input comes from SYSREF Divider, not SYSREF_MUX.	35
• Changed term pulsor to pulser throughout	36
• Changed DCLKout0_1_DIV to DCLKout0_DIV; DCLKout2_3_DIV to DCLKout2_DIV; DCLKout4_5_DIV to DCLKout4_DIV	37
• Added DCLKout4_DIV = 20	37
• Added DCLKout0_DDLY_PD = 0, DCLKout2_DDLY_PD = 0, DCLKout4_DDLY_PD = 0.....	37
• Changed text to read, <i>Set device clock and SYSREF divider digital delays: DCLKout0_DDLY_CNTH,</i>	

<i>DCLKout0_DDLY_CNTH, DCLKout2_DDLY_CNTH, DCLKout2_DDLY_CNTH, DCLKout4_DDLY_CNTH, DCLKout4_DDLY_CNTH, SYSREF_DDLY.</i>	37
• Added = 1 in SYSREF Request	38
• Changed step numbers in dynamic delay and references to steps to be correct, step 8 was duplicated	41
• Added note <i>LMK04821 includes VCO1 divider on VCO1 output.</i>	46
• Added note <i>LMK04821 includes VCO1 divider on VCO1 output.</i>	47
• Added <i>R/W bit = 0 is for SPI write. R/W bit = 1 is for SPI read.</i>	49
• Added <i>If using LMK04821, program register 0x174 in Recommended Programming Sequence</i>	49
• Added SYSREF_CLKin0_MUX and VCO1_DIV to register map	51
• Added CLKin_OVERRIDE bit to register map	52
• Changed from <i>half shift</i> to <i>half step</i>	57
• Changed definition of SDCLKoutY_DDLY value of 0 from <i>Reserved</i> to <i>Bypass</i>	57
• Changed from <i>Sets the polarity of SYSREF clocks</i> to <i>Sets the polarity of clock on SDCLKoutY when device clock output is selected with SDCLKoutY_MUX</i>	60
• Changed <i>Sets the polarity of the device clocks</i> to <i>Sets the polarity of the device clocks from the DCLKoutX outputs</i>	60
• Added LMK04821 DCLKoutX_FMT power on reset values as powerdown	60
• Changed from SYSREF to <i>SYSREF Divider</i> in Source column of <i>Register 0x13F</i>	64
• Changed reserved to Off for CLKin1_OUT_MUX	69
• Changed reserved to Off for CLKin0_OUT_MUX.	69
• Added CLKin_OVERRIDE bit	76
• Added LMK04821 register 0x174 for VCO1_DIV	91
• Deleted LMK04828 from Core line	102
• Added VCO1 Icc including VCO1 Divider for LMK04821	102
• Changed VCO1 Icc and power dissipated for LMK04828B/26B from 6 mA to 13.5 mA and 19.8 mW to 44.55 mW	102

Changes from Revision AO (March 2013) to Revision AP
Page

• Changed datasheet title from LMK04828 to LMK0482xB	1
• Changed LMK04828 family to LMK04820 family	1
• Changed image from LMK04828B to LMK0482xB	1
• Added LMK04826 to <i>Device Configuration Information</i> table	6
• Changed - increased LMK04828B VCO0 max frequency from 2600 MHz to 2630 MHz	6
• Changed - expanded LMK04828B VCO1 frequency range from 2945 - 3005 MHz to 2920 MHz - 3080 MHz	6
• Changed <i>Thermal Information</i> header from LMK04828B to LMK0482xB	9
• Added LMK04826 VCO Range Specification	13
• Changed - increased LMK04828B VCO0 max frequency from 2600 MHz to 2630 MHz	13
• Changed - expanded LMK04828B VCO1 frequency range from 2945 - 3005 MHz to 2920 MHz - 3080 MHz	13
• Added LMK04826 K_{VCO} specification	13
• Added clarification of LMK04828 specification vs LMK04826 specification for K_{VCO}	13
• Added LMK04826 noise floor data	14
• Changed - clarified phase noise data section header	15
• Added LMK04826 phase noise data	16
• Added LMK04826 jitter data	17
• Added LMK04826 $f_{CLKout-startup}$ spec	19
• Added clarification of LMK04828 specification vs. LMK04826 specification for $f_{CLKout-startup}$	19
• Added LMK04826B Phase Noise Performance Graph for VCO0	24
• Added LMK04826B Phase Noise Performance Graph for VCO1	24
• Added Added PLL2 loop filter bandwidth and phase margin info to plot	25

• Changed LMK04828 to LMK0482xB in <i>VCXO/Crystal Buffered Output</i>	28
• Changed LMK04828 to LMK0482xB in <i>Status Pins</i>	31
• Changed image from LMK04828 to LMK0482xB.....	46
• Changed - corrected value of PLL2_P selection to be 0 to correspond with register programming definition.	46
• Changed image from LMK04828 to LMK0482xB.....	47
• Changed image from LMK04828 to LMK0482xB.....	48
• Added LMK04826 register setting	55
• Added LMK04826 register setting	91
• Added LMK04826 register setting	92

5 Device Comparison Table

5.1 Device Configuration Information

PART NUMBER	REF-ERENCE INPUTS ⁽¹⁾	OSCO _{ut} (BUFFERED OSC _{in} Clock) LVDS/LVPECL/LVCMOS ⁽¹⁾	PLL2 PROGRAMMABLE LVDS/LVPECL/HSDS OUTPUTS	VCO0 FREQUENCY	VCO1 FREQUENCY
LMK04821	Up to 3	Up to 1	14	1930 to 2075 MHz	VCO1_DIV = ÷2 1460 to 1540 MHz
					VCO1_DIV = ÷3 974 to 1026 MHz
					VCO1_DIV = ÷4 730 to 770 MHz
					VCO1_DIV = ÷5 584 to 616 MHz
					VCO1_DIV = ÷6 487 to 513 MHz
					VCO1_DIV = ÷7 418 to 440 MHz
					VCO1_DIV = ÷8 365 to 385 MHz
LMK04826B	Up to 3	Up to 1	14	1840 to 1970 MHz	2440 to 2505 MHz
LMK04828B	Up to 3	Up to 1	14	2370 to 2630 MHz	2920 to 3080 MHz

(1) OSC_{out} may also be third clock input, CLK_{in2}.

6 Pin Configuration and Functions

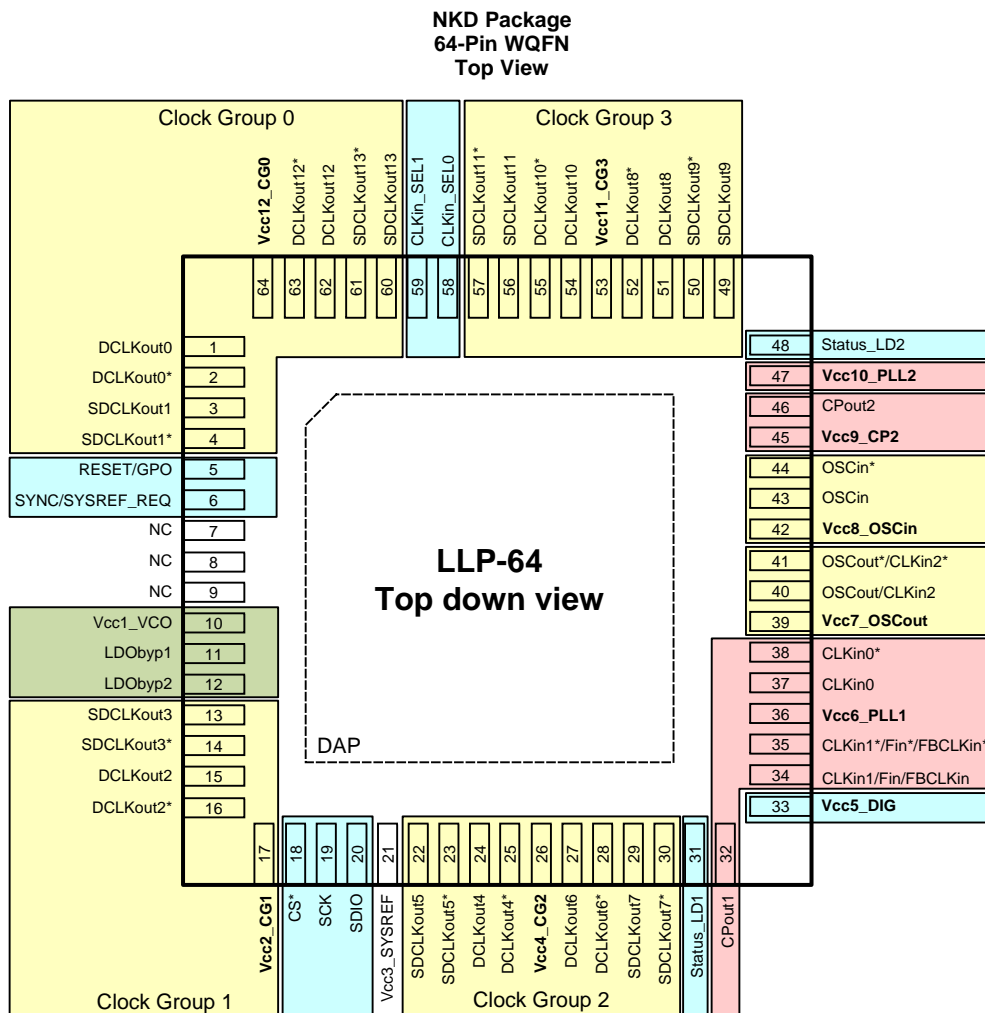

Pin Functions

NO.	PIN NAME	I/O	TYPE	DESCRIPTION ⁽¹⁾
1, 2	DCLKout0, DCLKout0*	O	Programmable	Device clock output 0.
3, 4	SDCLKout1, SDCLKout1*	O	Programmable	SYSREF / Device clock output 1
5	RESET/GPO	I	CMOS	Device reset input or GPO
6	SYNC/SYSREF_REQ	I	CMOS	Synchronization input or SYSREF_REQ for requesting continuous SYSREF.
7, 8, 9	NC			Do not connect. These pins must be left floating.
10	Vcc1_VCO		PWR	Power supply for VCO LDO.
11	LDObyp1		ANLG	LDO Bypass, bypassed to ground with 10-μF capacitor.
12	LDObyp2		ANLG	LDO Bypass, bypassed to ground with a 0.1-μF capacitor.
13, 14	SDCLKout3, SDCLKout3*	O	Programmable	SYSREF / Device Clock output 3.
15, 16	DCLKout2, DCLKout2*	O	Programmable	Device clock output 2.
17	Vcc2_CG1		PWR	Power supply for clock outputs 2 and 3.
18	CS*	I	CMOS	Chip Select
19	SCK	I	CMOS	SPI Clock

(1) See [Pin Connection Recommendations](#) for recommended connections.

Pin Functions (continued)

NO.	PIN	I/O	TYPE	DESCRIPTION ⁽¹⁾
	NAME			
20	SDIO	I/O	CMOS	SPI Data
21	Vcc3_SYSREF		PWR	Power supply for SYSREF divider and SYNC.
22, 23	SDCLKout5, SDCLKout5*	O	Programmable	SYSREF / Device clock output 5.
24, 25	DCLKout4, DCLKout4*	O	Programmable	Device clock output 4.
26	Vcc4_CG2		PWR	Power supply for clock outputs 4, 5, 6 and 7.
27, 28	DCLKout6, DCLKout6*	O	Programmable	Device clock output 6.
29, 30	SDCLKout7, SDCLKout7*	O	Programmable	SYSREF / Device clock output 7.
31	Status_LD1	I/O	Programmable	Programmable status pin.
32	CPout1	O	ANLG	Charge pump 1 output.
33	Vcc5_DIG		PWR	Power supply for the digital circuitry.
34, 35	CLKin1, CLKin1*	I	ANLG	Reference Clock Input Port 1 for PLL1.
	FBCLKin, FBCLKin*	I	ANLG	Feedback input for external clock feedback input (0–delay mode).
	Fin, Fin*	I	ANLG	External VCO Input (External VCO mode).
36	Vcc6_PLL1		PWR	Power supply for PLL1, charge pump 1, holdover DAC
37, 38	CLKin0, CLKin0*	I	ANLG	Reference Clock Input Port 0 for PLL1.
39	Vcc7_OSCout		PWR	Power supply for OSCout port.
40, 41	OSCCout, OSCout*	I/O	Programmable	Buffered output of OSCin port.
	CLKin2, CLKin2*			Reference Clock Input Port 2 for PLL1.
42	Vcc8_OSCin		PWR	Power supply for OSCin
43, 44	OSCCin, OSCin*	I	ANLG	Feedback to PLL1, Reference input to PLL2. AC coupled.
45	Vcc9_CP2		PWR	Power supply for PLL2 Charge Pump.
46	CPout2	O	ANLG	Charge pump 2 output.
47	Vcc10_PLL2		PWR	Power supply for PLL2.
48	Status_LD2	I/O	Programmable	Programmable status pin.
49, 50	SDCLKout9, SDCLKout9*	O	Programmable	SYSREF / Device clock 9
51, 52	DCLKout8, DCLKout8*	O	Programmable	Device clock output 8.
53	Vcc11_CG3		PWR	Power supply for clock outputs 8, 9, 10, and 11.
54, 55	DCLKout10, DCLKout10*	O	Programmable	Device clock output 10.
56, 57	SDCLKout11, SDCLKout11*	O	Programmable	SYSREF / Device clock output 11.
58	CLKin_SEL0	I/O	Programmable	Programmable status pin.
59	CLKin_SEL1	I/O	Programmable	Programmable status pin.
60, 61	SDCLKout13, SDCLKout13*	O	Programmable	SYSREF / Device clock output 13.
62, 63	DCLKout12, DCLKout12*	O	Programmable	Device clock output 12.
64	Vcc12_CG0		PWR	Power supply for clock outputs 0, 1, 12, and 13.
DAP	DAP		GND	DIE ATTACH PAD, connect to GND.

7 Specifications

7.1 Absolute Maximum Ratings

over operating free-air temperature range (unless otherwise noted) ⁽¹⁾

		MIN	MAX	UNIT
V _{CC}	Supply voltage ⁽²⁾	-0.3	3.6	V
V _{IN}	Input voltage	-0.3	(V _{CC} + 0.3)	V
T _L	Lead temperature (solder 4 seconds)		260	°C
T _J	Junction temperature		150	°C
I _{IN}	Differential input current (CLKinX/X*, OSCin/OSCin*, FBCLKin/FBCLKin*, Fin/Fin*)		± 5	mA
MSL	Moisture sensitivity level		3	
T _{stg}	Storage temperature	-65	150	°C

- (1) Stresses beyond those listed under *Absolute Maximum Ratings* may cause permanent damage to the device. These are stress ratings only, which do not imply functional operation of the device at these or any other conditions beyond those indicated under *Recommended Operating Conditions*. Exposure to absolute-maximum-rated conditions for extended periods may affect device reliability.
- (2) Never to exceed 3.6 V.

7.2 ESD Ratings

		VALUE	UNIT
V _(ESD)	Electrostatic discharge	Human-body model (HBM), per ANSI/ESDA/JEDEC JS-001 ⁽¹⁾	V
		Machine Model (MM)	
		Charged-device model (CDM), per JEDEC specification JESD22-C101 ⁽²⁾	

- (1) JEDEC document JEP155 states that 500-V HBM allows safe manufacturing with a standard ESD control process. Manufacturing with less than 500-V HBM is possible with the necessary precautions. Pins listed as ±2000 V may actually have higher performance.
- (2) JEDEC document JEP157 states that 250-V CDM allows safe manufacturing with a standard ESD control process. Manufacturing with less than 250-V CDM is possible with the necessary precautions. Pins listed as ±250 V may actually have higher performance.

7.3 Recommended Operating Conditions

over operating free-air temperature range (unless otherwise noted)

		MIN	TYP	MAX	UNIT
T _J	Junction Temperature			125	°C
T _A	Ambient Temperature	-40	25	85	°C
T _{PCB}	PCB Temperature (measured at thermal pad)			105	°C
V _{CC}	Supply Voltage	3.15	3.3	3.45	V

7.4 Thermal Information

THERMAL METRIC ⁽¹⁾		LMK0482x	UNIT
		NKD (WQFN)	
		64 PINS	
R _{θJA}	Junction-to-ambient thermal resistance ⁽²⁾	24.3	°C/W
R _{θJC(top)}	Junction-to-case (top) thermal resistance ⁽³⁾	6.1	°C/W
R _{θJB}	Junction-to-board thermal resistance ⁽⁴⁾	3.5	°C/W

- (1) For more information about traditional and new thermal metrics, see the *Semiconductor and IC Package Thermal Metrics* application report ([SPRA953](#)).
- (2) The junction-to-ambient thermal resistance under natural convection is obtained in a simulation on a JEDEC-standard, High-K board, as specified in JESD51-7, in an environment described in JESD51-2a.
- (3) The junction-to-case(top) thermal resistance is obtained by simulating a cold plate test on the package top. No specific JEDEC-standard test exists, but a close description can be found in the ANSI SEMI standard G30-88.
- (4) The junction-to-board thermal resistance is obtained by simulating in an environment with a ring cold plate fixture to control the PCB temperature, as described in JESD51-8.

Thermal Information (continued)

THERMAL METRIC ⁽¹⁾		LMK0482x	UNIT
		NKD (WQFN)	
		64 PINS	
Ψ_{JT}	Junction-to-top characterization parameter ⁽⁵⁾	0.1	°C/W
Ψ_{JB}	Junction-to-board characterization parameter ⁽⁶⁾	3.5	°C/W
$R_{\theta JC(bot)}$	Junction-to-case (bottom) thermal resistance ⁽⁷⁾	0.7	°C/W

- (5) The junction-to-top characterization parameter, Ψ_{JT} , estimates the junction temperature of a device in a real system and is extracted from the simulation data for obtaining $R_{\theta JA}$, using a procedure described in JESD51-2a (sections 6 and 7).
- (6) The junction-to-board characterization parameter, Ψ_{JB} estimates the junction temperature of a device in a real system and is extracted from the simulation data for obtaining $R_{\theta JA}$, using a procedure described in JESD51-2a (sections 6 and 7).
- (7) The junction-to-case(bottom) thermal resistance is obtained by simulating a cold plate test on the exposed (power) pad. No specific JEDEC standard test exists, but a close description can be found in the ANSI SEMI standard G30-88.

7.5 Electrical Characteristics

(3.15 V < V_{CC} < 3.45 V, -40 °C < T_A < 85 °C and $T_{PCB} \leq 105$ °C. Typical values at $V_{CC} = 3.3$ V, $T_A = 25$ °C, at the Recommended Operating Conditions and are **not** assured.)

PARAMETER		TEST CONDITIONS	MIN	TYP	MAX	UNIT
CURRENT CONSUMPTION						
I_{CC_PD}	Power Down Supply Current			1	3	mA
I_{CC_CLKS}	Supply Current ⁽¹⁾	14 HSDS 8 mA clocks enabled PLL1 and PLL2 locked.		565	665	mA
CLKin0/0*, CLKin1/1*, and CLKin2/2* INPUT CLOCK SPECIFICATIONS						
f_{CLKin}	Clock Input Frequency		0.001		750	MHz
$SLEW_{CLKin}$	Clock Input Slew Rate ⁽²⁾	20% to 80%	0.15	0.5		V/ns
$V_{ID}CLKin$	Clock Input Differential Input Voltage ⁽³⁾	AC coupled			1.55	V
$V_{SS}CLKin$			0.25		3.1	Vpp
V_{CLKin}	Clock Input Single-ended Input Voltage	AC coupled to CLKinX; CLKinX* AC coupled to Ground CLKinX_TYPE = 0 (Bipolar)	0.25		2.4	Vpp
		AC coupled to CLKinX; CLKinX* AC coupled to Ground CLKinX_TYPE = 1 (MOS)	0.35		2.4	Vpp
$ V_{CLKinX-offset} $	DC offset voltage between CLKinX/CLKinX* (CLKinX* - CLKinX)	Each pin AC coupled, CLKin0/1/2 CLKinX_TYPE = 0 (Bipolar)		0		mV
		Each pin AC coupled, CLKin0/1 CLKinX_TYPE = 1 (MOS)		55		mV
		Each pin AC coupled CLKin2/CLKin2* (CLKin2* - CLKin2)		20		mV
$V_{CLKin-} V_{IH}$	High input voltage	DC coupled to CLKinX; CLKinX* AC coupled to Ground	2.0		V_{CC}	V
$V_{CLKin-} V_{IL}$	Low input voltage	CLKinX_TYPE = 1 (MOS)	0.0		0.4	V
FBCLKin/FBCLKin* and Fin/Fin* INPUT SPECIFICATIONS						
$f_{FBCLKin}$	Clock Input Frequency for 0-delay with external feedback.	AC coupled CLKinX_TYPE = 0 (Bipolar)	0.001		750	MHz
f_{Fin}	Clock Input Frequency for external VCO or distribution mode.	AC coupled ⁽⁴⁾ CLKinX_TYPE = 0 (Bipolar)	0.001		3100	MHz

- (1) See the applications section of [Power Supply Recommendations](#) for I_{CC} for specific part configuration and how to calculate I_{CC} for a specific design.
- (2) In order to meet the jitter performance listed in the subsequent sections of this data sheet, the minimum recommended slew rate for all input clocks is 0.5 V/ns. This is especially true for single-ended clocks. Phase noise performance will begin to degrade as the clock input slew rate is reduced. However, the device will function at slew rates down to the minimum listed. When compared to single-ended clocks, differential clocks (LVDS, LVPECL) will be less susceptible to degradation in phase noise performance at lower slew rates due to their common mode noise rejection. However, it is also recommended to use the highest possible slew rate for differential clocks to achieve optimal phase noise performance at the device outputs.
- (3) See [Differential Voltage Measurement Terminology](#) for definition of V_{ID} and V_{OD} voltages.
- (4) Assured by characterization. ATE tested at 2949.12 MHz.

Electrical Characteristics (continued)

(3.15 V < V_{CC} < 3.45 V, –40 °C < T_A < 85 °C and T_{PCB} ≤ 105 °C. Typical values at V_{CC} = 3.3 V, T_A = 25 °C, at the Recommended Operating Conditions and are **not** assured.)

PARAMETER		TEST CONDITIONS	MIN	TYP	MAX	UNIT
V _{FBCLKin/Fin}	Single Ended Clock Input Voltage	AC coupled CLKinX_TYPE = 0 (Bipolar)	0.25		2.0	V _{pp}
SLEW _{FBCLKin/Fin}	Slew Rate on CLKin ⁽²⁾	AC coupled; 20% to 80%; (CLKinX_TYPE = 0)	0.15	0.5		V/ns
PLL1 SPECIFICATIONS						
f _{PD1}	PLL1 Phase Detector Frequency				40	MHz
I _{CPout1} SOURCE	PLL1 Charge Pump Source Current ⁽⁵⁾	V _{CPout1} = V _{CC} /2, PLL1_CP_GAIN = 0		50		μA
		V _{CPout1} = V _{CC} /2, PLL1_CP_GAIN = 1		150		
		V _{CPout1} = V _{CC} /2, PLL1_CP_GAIN = 2		250		
			
		V _{CPout1} = V _{CC} /2, PLL1_CP_GAIN = 14		1450		
		V _{CPout1} = V _{CC} /2, PLL1_CP_GAIN = 15		1550		
I _{CPout1} SINK	PLL1 Charge Pump Sink Current ⁽⁵⁾	V _{CPout1} = V _{CC} /2, PLL1_CP_GAIN = 0		–50		μA
		V _{CPout1} = V _{CC} /2, PLL1_CP_GAIN = 1		–150		
		V _{CPout1} = V _{CC} /2, PLL1_CP_GAIN = 2		–250		
			
		V _{CPout1} = V _{CC} /2, PLL1_CP_GAIN = 14		–1450		
		V _{CPout1} = V _{CC} /2, PLL1_CP_GAIN = 15		–1550		
I _{CPout1} %MIS	Charge Pump Sink / Source Mismatch	V _{CPout1} = V _{CC} /2, T = 25 °C		1%	10%	
I _{CPout1} V _{TUNE}	Magnitude of Charge Pump Current Variation vs. Charge Pump Voltage	0.5 V < V _{CPout1} < V _{CC} - 0.5 V T _A = 25 °C		4%		
I _{CPout1} %TEMP	Charge Pump Current vs. Temperature Variation			4%		
I _{CPout1} TRI	Charge Pump TRI-STATE Leakage Current	0.5 V < V _{CPout1} < V _{CC} - 0.5 V			5	nA
PN10kHz	PLL 1/f Noise at 10 kHz offset. Normalized to 1 GHz Output Frequency	PLL1_CP_GAIN = 350 μA		–117		dBc/Hz
		PLL1_CP_GAIN = 1550 μA		–118		
PN1Hz	Normalized Phase Noise Contribution	PLL1_CP_GAIN = 350 μA		–221.5		dBc/Hz
		PLL1_CP_GAIN = 1550 μA		–223		
PLL2 REFERENCE INPUT (OSCin) SPECIFICATIONS						
f _{OSCin}	PLL2 Reference Input ⁽⁶⁾				500	MHz
SLEW _{OSCin}	PLL2 Reference Clock minimum slew rate on OSCin ⁽²⁾	20% to 80%	0.15	0.5		V/ns
V _{OSCin}	Input Voltage for OSCin or OSCin*	AC coupled; Single-ended (Unused pin AC coupled to GND)	0.2		2.4	V _{pp}
V _{ID} OSCin	Differential voltage swing	AC coupled	0.2		1.55	V
V _{SS} OSCin	Figure 8		0.4		3.1	V _{pp}
V _{OSCin} -offset	DC offset voltage between OSCin/OSCin* (OSCinX* - OSCinX)	Each pin AC coupled		20		mV
f _{doubler_max}	Doubler input frequency ⁽⁷⁾	EN_PLL2_REF_2X = 1 ⁽⁸⁾ ; OSCin Duty Cycle 40% to 60%			155	MHz

(5) This parameter is programmable

(6) F_{OSCin} maximum frequency assured by characterization. Production tested at 122.88 MHz.

(7) Assured by characterization. ATE tested at 122.88 MHz.

(8) The EN_PLL2_REF_2X bit enables/disables a frequency doubler mode for the PLL2 OSCin path.

Electrical Characteristics (continued)

(3.15 V < V_{CC} < 3.45 V, –40 °C < T_A < 85 °C and T_{PCB} ≤ 105 °C. Typical values at V_{CC} = 3.3 V, T_A = 25 °C, at the Recommended Operating Conditions and are **not** assured.)

PARAMETER		TEST CONDITIONS	MIN	TYP	MAX	UNIT
CRYSTAL OSCILLATOR MODE SPECIFICATIONS						
F _{XTAL}	Crystal Frequency Range	Fundamental mode crystal ESR = 200 Ω (10 to 30 MHz) ESR = 125 Ω (30 to 40 MHz)	10		40	MHz
C _{IN}	Input Capacitance of OSCin port	–40 to 85 °C		1		pF
PLL2 PHASE DETECTOR and CHARGE PUMP SPECIFICATIONS						
f _{PD2}	Phase Detector Frequency ⁽⁷⁾				155	MHz
I _{CPout} SOURCE	PLL2 Charge Pump Source Current ⁽⁵⁾	V _{CPout2} =V _{CC} /2, PLL2_CP_GAIN = 0		100		μA
		V _{CPout2} =V _{CC} /2, PLL2_CP_GAIN = 1		400		
		V _{CPout2} =V _{CC} /2, PLL2_CP_GAIN = 2		1600		
		V _{CPout2} =V _{CC} /2, PLL2_CP_GAIN = 3		3200		
I _{CPout} SINK	PLL2 Charge Pump Sink Current ⁽⁵⁾	V _{CPout2} =V _{CC} /2, PLL2_CP_GAIN = 0		–100		μA
		V _{CPout2} =V _{CC} /2, PLL2_CP_GAIN = 1		–400		
		V _{CPout2} =V _{CC} /2, PLL2_CP_GAIN = 2		–1600		
		V _{CPout2} =V _{CC} /2, PLL2_CP_GAIN = 3		–3200		
I _{CPout2} %MIS	Charge Pump Sink/Source Mismatch	V _{CPout2} =V _{CC} /2, T _A = 25 °C		1%	10%	
I _{CPout2} V _{TUNE}	Magnitude of Charge Pump Current vs. Charge Pump Voltage Variation	0.5 V < V _{CPout2} < V _{CC} - 0.5 V T _A = 25 °C		4%		
I _{CPout2} %TEMP	Charge Pump Current vs. Temperature Variation			4%		
I _{CPout2} TRI	Charge Pump Leakage	0.5 V < V _{CPout2} < V _{CC} - 0.5 V			10	nA
PN10kHz	PLL 1/f Noise at 10 kHz offset ⁽⁹⁾ . Normalized to 1 GHz Output Frequency	PLL2_CP_GAIN = 400 μA		–118		dBc/Hz
		PLL2_CP_GAIN = 3200 μA		–121		
PN1Hz	Normalized Phase Noise Contribution ⁽¹⁰⁾	PLL2_CP_GAIN = 400 μA		–222.5		dBc/Hz
		PLL2_CP_GAIN = 3200 μA		–227		

(9) A specification in modeling PLL in-band phase noise is the 1/f flicker noise, L_{PLL_flicker}(f), which is dominant close to the carrier. Flicker noise has a 10 dB/decade slope. PN10kHz is normalized to a 10 kHz offset and a 1 GHz carrier frequency. PN10kHz = L_{PLL_flicker}(10 kHz) - 20log(Fout / 1 GHz), where L_{PLL_flicker}(f) is the single side band phase noise of only the flicker noise's contribution to total noise, L(f). To measure L_{PLL_flicker}(f) it is important to be on the 10 dB/decade slope close to the carrier. A high compare frequency and a clean crystal are important to isolating this noise source from the total phase noise, L(f). L_{PLL_flicker}(f) can be masked by the reference oscillator performance if a low power or noisy source is used. The total PLL in-band phase noise performance is the sum of L_{PLL_flicker}(f) and L_{PLL_flat}(f).

(10) A specification modeling PLL in-band phase noise. The normalized phase noise contribution of the PLL, L_{PLL_flat}(f), is defined as: PN1Hz=L_{PLL_flat}(f) - 20log(N) - 10log(f_{PDx}). L_{PLL_flat}(f) is the single side band phase noise measured at an offset frequency, f, in a 1 Hz bandwidth and f_{PDx} is the phase detector frequency of the synthesizer. L_{PLL_flat}(f) contributes to the total noise, L(f).

Electrical Characteristics (continued)

(3.15 V < V_{CC} < 3.45 V, –40 °C < T_A < 85 °C and T_{PCB} ≤ 105 °C. Typical values at V_{CC} = 3.3 V, T_A = 25 °C, at the Recommended Operating Conditions and are **not** assured.)

PARAMETER		TEST CONDITIONS	MIN	TYP	MAX	UNIT
INTERNAL VCO SPECIFICATIONS						
f _{VCO}	LMK04821 VCO Tuning Range	VCO0	1930		2075	MHz
		VCO1 ⁽¹¹⁾	2920		3080	
	LMK04826 VCO Tuning Range	VCO0	1840		1970	MHz
		VCO1	2440		2505	
	LMK04828 VCO Tuning Range	VCO0	2370		2630	MHz
		VCO1	2920		3080	
K _{VCO}	LMK04821 Fine Tuning Sensitivity	LMK04821 VCO0	12 to 20		MHz/V	
		LMK04821 VCO1	15 to 24			
	LMK04826 Fine Tuning Sensitivity	LMK04826 VCO0	11 to 19		MHz/V	
		LMK04826 VCO1	8 to 11			
	LMK04828 Fine Tuning Sensitivity	LMK04828 VCO0 at 2457.6 MHz	17 to 27		MHz/V	
		LMK04828 VCO1 at 2949.12 MHz	17 to 23			
ΔT _{CL}	Allowable Temperature Drift for Continuous Lock ⁽¹²⁾	After programming for lock, no changes to output configuration are permitted to assure continuous lock			125	°C

- (11) The VCO1 divider, VCO1_DIV in register 0x174, can be programmed to ÷2 to ÷8 resulting in a lower effective VCO frequency range as shown in [Device Configuration Information](#).
- (12) Maximum Allowable Temperature Drift for Continuous Lock is how far the temperature can drift in either direction from the value it was at the time that the 0x168 register was last programmed with PLL2_FCAL_DIS = 0, and still have the part stay in lock. The action of programming the 0x168 register, even to the same value, activates a frequency calibration routine. This implies the part will work over the entire frequency range, but if the temperature drifts more than the maximum allowable drift for continuous lock, then it will be necessary to reload the appropriate register to ensure it stays in lock. Regardless of what temperature the part was initially programmed at, the temperature can never drift outside the frequency range of –40 °C to 85 °C without violating specifications.

Electrical Characteristics (continued)

(3.15 V < V_{CC} < 3.45 V, –40 °C < T_A < 85 °C and T_{PCB} ≤ 105 °C. Typical values at V_{CC} = 3.3 V, T_A = 25 °C, at the Recommended Operating Conditions and are **not** assured.)

PARAMETER		TEST CONDITIONS	MIN	TYP	MAX	UNIT
NOISE FLOOR						
L(f) _{CLKout}	LMK04821, VCO0, Noise Floor 20 MHz Offset ⁽¹³⁾	245.76 MHz	LVDS		–158.2	dBc/Hz
			HSDS 6 mA		–160	
			HSDS 8 mA		–161	
			HSDS 10 mA		–161.4	
			LVPECL16 /w 240 Ω		–161.6	
			LVPECL20 /w 240 Ω		–162	
			LVPECL		161.7	
L(f) _{CLKout}	LMK04821, VCO1, Noise Floor 20 MHz Offset ⁽¹³⁾	245.76 MHz	LVDS		–157.1	dBc/Hz
			HSDS 6 mA		–158.3	
			HSDS 8 mA		–159	
			HSDS 10 mA		–159.2	
			LVPECL16 /w 240 Ω		–158.8	
			LVPECL20 /w 240 Ω		–158.9	
			LVPECL		–158.8	
L(f) _{CLKout}	LMK04826, VCO0, Noise Floor 20 MHz Offset ⁽¹⁴⁾	245.76 MHz	LVDS		–158.1	dBc/Hz
			HSDS 6 mA		–159.7	
			HSDS 8 mA		–160.8	
			HSDS 10 mA		–161.3	
			LVPECL16 /w 240 Ω		–161.8	
			LVPECL20 /w 240 Ω		–162.0	
			LCPECL		–161.7	
L(f) _{CLKout}	LMK04826, VCO1, Noise Floor 20 MHz Offset ⁽¹⁴⁾	245.76 MHz	LVDS		–157.5	dBc/Hz
			HSDS 6 mA		–158.9	
			HSDS 8 mA		–159.8	
			HSDS 10 mA		–160.3	
			LVPECL16 /w 240 Ω		–160.8	
			LVPECL20 /w 240 Ω		–160.7	
			LCPECL		–160.7	

(13) Data collected using a Prodyn BIB-100G balun. Loop filter is C1 = 47 pF, C2 = 3.9 nF, R2 = 620 Ω, C3 = 10 pF, R3 = 200 Ω, C4 = 10 pF, R4 = 200 Ω, PLL1_CP = 450 μA, PLL2_CP = 3.2 mA.. VCO0 PLL2 loop filter bandwidth = 288 kHz, phase margin = 72 degrees. VCO1 Loop filter loop bandwidth = 221 kHz, phase margin = 70 degrees. CLKoutX_Y_IDL = 1, CLKoutX_Y_ODL = 0.

(14) Data collected using a Prodyn BIB-100G balun. Loop filter for PLL2 is C1 = 47 pF, C2 = 3.9 nF, R2 = 620 Ω, C3 = 10 pF, R3 = 200 Ω, C4 = 10 pF, R4 = 200 Ω, PLL1_CP = 450 μA, PLL2_CP = 3.2 mA.. VCO0 loop filter bandwidth = 303 kHz, phase margin = 73 degrees. VCO1 Loop filter loop bandwidth = 151 kHz, phase margin = 64 degrees. CLKoutX_Y_IDL = 1, CLKoutX_Y_ODL = 0.

Electrical Characteristics (continued)

(3.15 V < V_{CC} < 3.45 V, –40 °C < T_A < 85 °C and T_{PCB} ≤ 105 °C. Typical values at V_{CC} = 3.3 V, T_A = 25 °C, at the Recommended Operating Conditions and are **not** assured.)

PARAMETER		TEST CONDITIONS		MIN	TYP	MAX	UNIT	
NOISE FLOOR (continued)								
L(f) _{CLKout}	LMK04828, VCO0, Noise Floor 20 MHz Offset ⁽¹⁵⁾	245.76 MHz	LVDS		–156.3		dBc/Hz	
			HSDS 6 mA		–158.4			
			HSDS 8 mA		–159.3			
			HSDS 10 mA		–158.9			
			LVPECL16 /w 240 Ω		–161.6			
			LVPECL20 /w 240 Ω		–162.5			
			LCPECL		–162.1			
L(f) _{CLKout}	LMK04828, VCO1, Noise Floor 20 MHz Offset ⁽¹⁵⁾	245.76 MHz	LVDS		–155.7		dBc/Hz	
			HSDS 6 mA		–157.5			
			HSDS 8 mA		–158.1			
			HSDS 10 mA		–157.7			
			LVPECL16 /w 240 Ω		–160.3			
			LVPECL20 /w 240 Ω		–161.1			
			LCPECL		–160.8			
CLKout CLOSED LOOP PHASE NOISE SPECIFICATIONS a COMMERCIAL QUALITY VCXO ⁽¹⁶⁾								
L(f) _{CLKout}	LMK04821 VCO0 SSB Phase Noise ⁽¹³⁾ 245.76 MHz		Offset = 1 kHz		–126.9		dBc/Hz	
			Offset = 10 kHz		–133.5			
			Offset = 100 kHz		–135.4			
			Offset = 1 MHz		–149.8			
			Offset = 10 MHz	LVDS		–158.1		
				HSDS 8 mA		–161.1		
				LVPECL16 /w 240 Ω		–161.7		
L(f) _{CLKout}	LMK04821 VCO1 SSB Phase Noise ⁽¹³⁾ 245.76 MHz		Offset = 1 kHz		–126.8		dBc/Hz	
			Offset = 10 kHz		–133.4			
			Offset = 100 kHz		–135.4			
			Offset = 1 MHz		–151.8			
			Offset = 10 MHz	LVDS		–157.2		
				HSDS 8 mA		–159.1		
				LVPECL16 /w 240 Ω		–158.9		

(15) Data collected using ADT2-1T+ balun. Loop filter is C1 = 47 pF, C2 = 3.9 nF, R2 = 620 Ω, C3 = 10 pF, R3 = 200 Ω, C4 = 10 pF, R4 = 200 Ω, PLL1_CP = 450 μA, PLL2_CP = 3.2 mA. VCO0 loop filter bandwidth = 344 kHz, phase margin = 73 degrees. VCO1 Loop filter loop bandwidth = 233 kHz, phase margin = 70 degrees. CLKoutX_Y_IDL = 1, CLKoutX_Y_ODL = 0.

(16) VCXO used is a 122.88 MHz Crystek CVHD-950-122.880.

Electrical Characteristics (continued)

(3.15 V < V_{CC} < 3.45 V, –40 °C < T_A < 85 °C and T_{PCB} ≤ 105 °C. Typical values at V_{CC} = 3.3 V, T_A = 25 °C, at the Recommended Operating Conditions and are **not** assured.)

PARAMETER		TEST CONDITIONS		MIN	TYP	MAX	UNIT
CLKout CLOSED LOOP PHASE NOISE SPECIFICATIONS a COMMERCIAL QUALITY VCXO (continued)							
L(f) _{CLKout}	LMK04826B VCO0 SSB Phase Noise ⁽¹⁴⁾ 245.76 MHz	Offset = 10 kHz			–134.8		dBc/Hz
		Offset = 100 kHz			–135.4		
		Offset = 1 MHz	LVDS		–148.2		
			HSDS 8 mA LVPECL16 /w 240 Ω		–148.6		
		Offset = 10 MHz	LVDS		–157.8		
			HSDS 8 mA		–160.4		
			LVPECL16 /w 240 Ω		–161.5		
L(f) _{CLKout}	LMK04826B VCO1 SSB Phase Noise ⁽¹⁴⁾ 245.76 MHz	Offset = 10 kHz			–134.3		dBc/Hz
		Offset = 100 kHz			–133.7		
		Offset = 1 MHz	LVDS		–152.5		
			HSDS 8 mA LVPECL16 /w 240 Ω		–153.6		
		Offset = 10 MHz	LVDS		–157.3		
			HSDS 8 mA		–159.6		
			LVPECL16 /w 240 Ω		–160.5		
L(f) _{CLKout}	LMK04828 VCO0 SSB Phase Noise ⁽¹⁵⁾ 245.76 MHz	Offset = 1 kHz			–124.3		dBc/Hz
		Offset = 10 kHz			–134.7		
		Offset = 100 kHz			–136.5		
		Offset = 1 MHz			–148.4		
		Offset = 10 MHz	LVDS		–156.4		
			HSDS 8 mA		–159.1		
			LVPECL16 /w 240 Ω		–160.8		
L(f) _{CLKout}	LMK04828 VCO1 SSB Phase Noise ⁽¹⁵⁾ 245.76 MHz	Offset = 1 kHz			–124.2		dBc/Hz
		Offset = 10 kHz			–134.4		
		Offset = 100 kHz			–135.2		
		Offset = 1 MHz			–151.5		
		Offset = 10 MHz	LVDS		–159.9		
			HSDS 8 mA		–155.8		
			LVPECL16 /w 240 Ω		–158.1		

Electrical Characteristics (continued)

(3.15 V < V_{CC} < 3.45 V, –40 °C < T_A < 85 °C and T_{PCB} ≤ 105 °C. Typical values at V_{CC} = 3.3 V, T_A = 25 °C, at the Recommended Operating Conditions and are **not** assured.)

PARAMETER		TEST CONDITIONS	MIN	TYP	MAX	UNIT
CLKout CLOSED LOOP JITTER SPECIFICATIONS a COMMERCIAL QUALITY VCXO⁽¹⁶⁾						
J _{CLKout}	LMK04821, VCO0 f _{CLKout} = 245.76 MHz Integrated RMS Jitter ⁽¹³⁾	LVDS, BW = 12 kHz to 20 MHz		99		fs rms
		HSDS 8 mA, BW = 12 kHz to 20 MHz		94		
		LVPECL16 /w 240 Ω, BW = 12 kHz to 20 MHz		96		
		LVPECL20 /w 240 Ω, BW = 12 kHz to 20 MHz		94		
		LCPECL /w 240 Ω, BW = 12 kHz to 20 MHz		93		
	LMK04821, VCO1 f _{CLKout} = 245.76 MHz Integrated RMS Jitter ⁽¹³⁾	LVDS, BW = 12 kHz to 20 MHz		96		fs rms
		HSDS 8 mA, BW = 12 kHz to 20 MHz		90		
		LVPECL16 /w 240 Ω, BW = 12 kHz to 20 MHz		92		
		LVPECL20 /w 240 Ω, BW = 12 kHz to 20 MHz		91		
		LCPECL /w 240 Ω, BW = 12 kHz to 20 MHz		91		
CLKout CLOSED LOOP JITTER SPECIFICATIONS a COMMERCIAL QUALITY VCXO (continued)⁽¹⁶⁾						
J _{CLKout}	LMK04826B, VCO0 f _{CLKout} = 245.76 MHz Integrated RMS Jitter ⁽¹⁴⁾	LVDS, BW = 100 Hz to 20 MHz		106		fs rms
		LVDS, BW = 12 kHz to 20 MHz		104		
		HSDS 8 mA, BW = 100 Hz to 20 MHz		99		
		HSDS 8 mA, BW = 12 kHz to 20 MHz		97		
		LVPECL16 /w 240 Ω, BW = 100 Hz to 20 MHz		99		
		LVPECL16 /w 240 Ω, BW = 12 kHz to 20 MHz		96		
		LCPECL /w 240 Ω, BW = 100 Hz to 20 MHz		100		
		LCPECL /w 240 Ω, BW = 12 kHz to 20 MHz		97		
	LMK04826, VCO1 f _{CLKout} = 245.76 MHz Integrated RMS Jitter ⁽¹⁴⁾	LVDS, BW = 100 Hz to 20 MHz		99		fs rms
		LVDS, BW = 12 kHz to 20 MHz		97		
		HSDS 8 mA, BW = 100 Hz to 20 MHz		92		
		HSDS 8 mA, BW = 12 kHz to 20 MHz		90		
		LVPECL16 /w 240 Ω, BW = 100 Hz to 20 MHz		91		
		LVPECL20 /w 240 Ω, BW = 12 kHz to 20 MHz		89		
		LCPECL /w 240 Ω, BW = 100 Hz to 20 MHz		92		
		LCPECL /w 240 Ω, BW = 12 kHz to 20 MHz		89		

Electrical Characteristics (continued)

(3.15 V < V_{CC} < 3.45 V, –40 °C < T_A < 85 °C and T_{PCB} ≤ 105 °C. Typical values at V_{CC} = 3.3 V, T_A = 25 °C, at the Recommended Operating Conditions and are **not** assured.)

PARAMETER		TEST CONDITIONS	MIN	TYP	MAX	UNIT
CLKout CLOSED LOOP JITTER SPECIFICATIONS a COMMERCIAL QUALITY VCXO (continued)⁽¹⁶⁾						
J _{CLKout}	LMK04828, VCO0 f _{CLKout} = 245.76 MHz Integrated RMS Jitter ⁽¹⁵⁾	LVDS, BW = 100 Hz to 20 MHz		112		fs rms
		LVDS, BW = 12 kHz to 20 MHz		109		
		HSDS 8 mA, BW = 100 Hz to 20 MHz		102		
		HSDS 8 mA, BW = 12 kHz to 20 MHz		99		
		LVPECL16 /w 240 Ω, BW = 100 Hz to 20 MHz		98		
		LVPECL20 /w 240 Ω, BW = 12 kHz to 20 MHz		95		
		LCPECL /w 240 Ω, BW = 100 Hz to 20 MHz		96		
		LCPECL /w 240 Ω, BW = 12 kHz to 20 MHz		93		
	LMK04828, VCO1 f _{CLKout} = 245.76 MHz Integrated RMS Jitter ⁽¹⁵⁾	LVDS, BW = 100 Hz to 20 MHz		108		fs rms
		LVDS, BW = 12 kHz to 20 MHz		105		
		HSDS 8 mA, BW = 100 Hz to 20 MHz		98		
		HSDS 8 mA, BW = 12 kHz to 20 MHz		94		
		LVPECL16 /w 240 Ω, BW = 100 Hz to 20 MHz		93		
		LVPECL20 /w 240 Ω, BW = 12 kHz to 20 MHz		90		
LCPECL /w 240 Ω, BW = 100 Hz to 20 MHz			91			
LCPECL /w 240 Ω, BW = 12 kHz to 20 MHz			88			

Electrical Characteristics (continued)

(3.15 V < V_{CC} < 3.45 V, –40 °C < T_A < 85 °C and T_{PCB} ≤ 105 °C. Typical values at V_{CC} = 3.3 V, T_A = 25 °C, at the Recommended Operating Conditions and are **not** assured.)

PARAMETER		TEST CONDITIONS	MIN	TYP	MAX	UNIT
DEFAULT POWER on RESET CLOCK OUTPUT FREQUENCY						
f _{CLKout-startup}	Default output clock frequency at device power on ⁽¹⁷⁾⁽¹⁸⁾	LMK04826		235		MHz
		LMK04828		315		
f _{OScout}	OScout Frequency	⁽⁷⁾			500	MHz
CLOCK SKEW and DELAY						
T _{SKEW}	DCLKoutX to SDCLKoutY F _{CLK} = 245.76 MHz, R _L = 100 Ω AC coupled ⁽¹⁹⁾	Same pair, Same format ⁽²⁰⁾ SDCLKoutY_MUX = 0 (Device Clock)			25	ps
	Maximum DCLKoutX or SDCLKoutY to DCLKoutX or SDCLKoutY F _{CLK} = 245.76 MHz, R _L = 100 Ω AC coupled	Any pair, Same format ⁽²⁰⁾ SDCLKoutY_MUX = 0 (Device Clock)		50		
t _{SJESD204B}	SYSREF to Device Clock setup time base reference. See SYSREF to Device Clock Alignment to adjust SYSREF to Device Clock setup time as required.	SDCLKoutY_MUX = 1 (SYSREF) SYSREF_DIV = 30 SYSREF_DDLY = 8 (global) SDCLKoutY_DDLY = 1 (2 cycles, local) DCLKoutX_MUX = 1 (Div+DCC+HS) DCLKoutX_DIV = 30 DCLKoutX_DDLY_CNTH = 7 DCLKoutX_DDLY_CNTL = 6 DCLKoutX_HS = 0 SDCLKoutY_HS = 0		–80		ps
t _{PD} CLKin0_ SDCLKout1	Propagation Delay from CLKin0 to SDCLKout1	CLKin0_OUT_MUX = 0 (SYSREF Mux) SYSREF_CLKin0_MUX = 1 (CLKin0) SDCLKout1_PD = 0 SDCLKout1_DDLY = 0 (Bypass) SDCLKout1_MUX = 1 (SR) EN_SYNC = 1 LVPECL16 /w 240 Ω		0.65		ns
f _{ADLYmax}	Maximum analog delay frequency	DCLKoutX_MUX = 4		1536		MHz
LVDS CLOCK OUTPUTS (DCLKoutX, SDCLKoutY, and OSCout)						
V _{OD}	Differential Output Voltage			395		mV
ΔV _{OD}	Change in Magnitude of V _{OD} for complementary output states	T = 25 °C, DC measurement AC coupled to receiver input R _L = 100 Ω differential termination		–60	60	mV
V _{OS}	Output Offset Voltage		1.125	1.25	1.375	V
ΔV _{OS}	Change in V _{OS} for complementary output states				35	mV
T _R / T _F	Output Rise Time	20% to 80%, R _L = 100 Ω, 245.76 MHz		180		ps
	Output Fall Time	80% to 20%, R _L = 100 Ω				
I _{SA} I _{SB}	Output short circuit current - single ended	Single-ended output shorted to GND T = 25 °C	–24		24	mA
I _{SAB}	Output short circuit current - differential	Complimentary outputs tied together	–12		12	mA

(17) OSCout will oscillate at start-up at the frequency of the VCXO attached to OSCin port.

(18) LMK04821 has no DCLKoutX or SDCLKoutY outputs which oscillate at power on. Only OSCout oscillates at power on.

(19) Equal loading and identical clock output configuration on each clock output is required for specification to be valid. Specification not valid for delay mode.

(20) LVPECL uses 120 Ω emitter resistor, LVDS and HSDS uses 560 Ω shunt.

Electrical Characteristics (continued)

(3.15 V < V_{CC} < 3.45 V, –40 °C < T_A < 85 °C and T_{PCB} ≤ 105 °C. Typical values at V_{CC} = 3.3 V, T_A = 25 °C, at the Recommended Operating Conditions and are **not** assured.)

PARAMETER		TEST CONDITIONS	MIN	TYP	MAX	UNIT
6 mA HSDS CLOCK OUTPUTS (DCLKoutX and SDCLKoutY)						
V _{OH}		T = 25 °C, DC measurement Termination = 50 Ω to V _{CC} - 1.42 V		V _{CC} - 1.05		
V _{OL}				V _{CC} - 1.64		
V _{OD}	Differential Output Voltage			590		mV
ΔV _{OD}	Change in V _{OD} for complementary output states		–80		80	mVpp
8 mA HSDS CLOCK OUTPUTS (DCLKoutX and SDCLKoutY)						
T _R / T _F	Output Rise Time	245.76 MHz, 20% to 80%, R _L = 100 Ω		170		ps
	Output Fall Time	245.76 MHz, 80% to 20%, R _L = 100 Ω				
V _{OH}		T = 25 °C, DC measurement Termination = 50 Ω to V _{CC} - 1.64 V		V _{CC} - 1.26		
V _{OL}				V _{CC} - –2.06		
V _{OD}	Differential Output Voltage			800		mV
ΔV _{OD}	Change in V _{OD} for complementary output states		–115		115	mVpp
10 mA HSDS CLOCK OUTPUTS (DCLKoutX and SDCLKoutY)						
V _{OH}		T = 25 °C, DC measurement Termination = 50 Ω to V _{CC} - 1.43 V		V _{CC} - 0.99		
V _{OL}				V _{CC} - 1.97		
V _{OD}				980		mVpp
ΔV _{OD}	Change in V _{OD} for complementary output states		–115		115	mVpp
LVPECL CLOCK OUTPUTS (DCLKoutX and SDCLKoutY)						
T _R / T _F	20% to 80% Output Rise	R _L = 100 Ω, emitter resistors = 240 Ω to GND DCLKoutX_TYPE = 4 or 5 (1600 or 2000 mVpp)		150		ps
	80% to 20% Output Fall Time					
1600 mVpp LVPECL CLOCK OUTPUTS (DCLKoutX and SDCLKoutY)						
V _{OH}	Output High Voltage	DC Measurement Termination = 50 Ω to V _{CC} - 2.0 V		V _{CC} - 1.04		V
V _{OL}	Output Low Voltage			V _{CC} - 1.80		V
V _{OD}	Output Voltage Figure 9			760		mV
2000 mVpp LVPECL CLOCK OUTPUTS (DCLKoutX and SDCLKoutY)						
V _{OH}	Output High Voltage	DC Measurement Termination = 50 Ω to V _{CC} - 2.3 V		V _{CC} - 1.09		V
V _{OL}	Output Low Voltage			V _{CC} - 2.05		V
V _{OD}	Output Voltage Figure 9			960		mV
LCPECL CLOCK OUTPUTS (DCLKoutX and SDCLKoutY)						
V _{OH}	Output High Voltage	DC Measurement Termination = 50 Ω to 0.5 V		1.57		V
V _{OL}	Output Low Voltage			0.62		V
V _{OD}	Output Voltage Figure 9			950		mV

Electrical Characteristics (continued)

(3.15 V < V_{CC} < 3.45 V, –40 °C < T_A < 85 °C and T_{PCB} ≤ 105 °C. Typical values at V_{CC} = 3.3 V, T_A = 25 °C, at the Recommended Operating Conditions and are **not** assured.)

PARAMETER		TEST CONDITIONS	MIN	TYP	MAX	UNIT
LVCMOS CLOCK OUTPUTS (OSCout)						
f _{CLKout}	Maximum Frequency (21)	5 pF Load	250			MHz
V _{OH}	Output High Voltage	1 mA Load	V _{CC} - 0.1			V
V _{OL}	Output Low Voltage	1 mA Load			0.1	V
I _{OH}	Output High Current (Source)	V _{CC} = 3.3 V, V _O = 1.65 V		28		mA
I _{OL}	Output Low Current (Sink)	V _{CC} = 3.3 V, V _O = 1.65 V		28		mA
DUTY _{CLK}	Output Duty Cycle ⁽²²⁾	V _{CC} /2 to V _{CC} /2, F _{CLK} = 100 MHz, T = 25 °C		50%		
T _R	Output Rise Time	20% to 80%, R _L = 50 Ω, C _L = 5 pF		400		ps
T _F	Output Fall Time	80% to 20%, R _L = 50 Ω, C _L = 5 pF		400		ps
DIGITAL OUTPUTS (CLKin_SELX, Status_LDX, and RESET/GPO)						
V _{OH}	High-Level Output Voltage	I _{OH} = –500 μA CLKin_SELX_TYPE = 3 or 4 Status_LDX_TYPE = 3 or 4 RESET_TYPE = 3 or 4	V _{CC} - 0.4			V
V _{OL}	Low-Level Output Voltage	I _{OL} = 500 μA CLKin_SELX_TYPE = 3, 4, or 6 Status_LDX_TYPE = 3, 4, or 6 RESET_TYPE = 3, 4, or 6			0.4	V
DIGITAL OUTPUT (SDIO)						
V _{OH}	High-Level Output Voltage	I _{OH} = –500 μA ; During SPI read. SDIO_RDBK_TYPE = 0	V _{CC} - 0.4			V
V _{OL}	Low-Level Output Voltage	I _{OL} = 500 μA ; During SPI read. SDIO_RDBK_TYPE = 0 or 1			0.4	V
DIGITAL INPUTS (CLKinX_SEL, RESET/GPO, SYNC, SCK, SDIO, or CS*)						
V _{IH}	High-Level Input Voltage		1.2		V _{CC}	V
V _{IL}	Low-Level Input Voltage				0.4	V
DIGITAL INPUTS (CLKinX_SEL)						
I _{IH}	High-Level Input Current V _{IH} = V _{CC}	CLKin_SELX_TYPE = 0, (High Impedance)	–5		5	μA
		CLKin_SELX_TYPE = 1 (Pull-up)	–5		5	
		CLKin_SELX_TYPE = 2 (Pull-down)	10		80	
I _{IL}	Low-Level Input Current V _{IL} = 0 V	CLKin_SELX_TYPE = 0, (High Impedance)	–5		5	μA
		CLKin_SELX_TYPE = 1 (Pull-up)	–40		–5	
		CLKin_SELX_TYPE = 2 (Pull-down)	–5		5	
DIGITAL INPUT (RESET/GPO)						
I _{IH}	High-Level Input Current V _{IH} = V _{CC}	RESET_TYPE = 2 (Pull-down)	10		80	μA
I _{IL}	Low-Level Input Current V _{IL} = 0 V	RESET_TYPE = 0 (High Impedance)	–5		5	μA
		RESET_TYPE = 1 (Pull-up)	–40		–5	
		RESET_TYPE = 2 (Pull-down)	–5		5	
DIGITAL INPUTS (SYNC)						
I _{IH}	High-Level Input Current	V _{IH} = V _{CC}			25	μA
I _{IL}	Low-Level Input Current	V _{IL} = 0 V	–5		5	
DIGITAL INPUTS (SCK, SDIO, CS*)						

(21) Assured by characterization. ATE tested to 10 MHz.

(22) Assumes OSCin has 50% input duty cycle.

Electrical Characteristics (continued)

($3.15\text{ V} < V_{CC} < 3.45\text{ V}$, $-40\text{ }^{\circ}\text{C} < T_A < 85\text{ }^{\circ}\text{C}$ and $T_{PCB} \leq 105\text{ }^{\circ}\text{C}$. Typical values at $V_{CC} = 3.3\text{ V}$, $T_A = 25\text{ }^{\circ}\text{C}$, at the Recommended Operating Conditions and are **not** assured.)

PARAMETER		TEST CONDITIONS	MIN	TYP	MAX	UNIT
I_{IH}	High-Level Input Current	$V_{IH} = V_{CC}$	-5		5	μA
I_{IL}	Low-Level Input Current	$V_{IL} = 0$	-5		5	μA
DIGITAL INPUT TIMING						
t_{HIGH}		RESET pin held high for device reset	25			ns

7.6 SPI Interface Timing

		TEST CONDITIONS	MIN	TYP	MAX	UNIT
t_{d_s}	Setup time for SDI edge to SCLK rising edge	See Figure 1	10			ns
t_{d_H}	Hold time for SDI edge from SCLK rising edge	See Figure 1	10			ns
t_{SCLK}	Period of SCLK	See Figure 1	50 ⁽¹⁾			ns
t_{HIGH}	High width of SCLK	See Figure 1	25			ns
t_{LOW}	Low width of SCLK	See Figure 1	25			ns
t_{c_s}	Setup time for CS* falling edge to SCLK rising edge	See Figure 1	10			ns
t_{c_H}	Hold time for CS* rising edge from SCLK rising edge	See Figure 1	30			ns
t_{d_v}	SCLK falling edge to valid read back data	See Figure 1			20	ns

(1) 20 MHz

Register programming information on the SDIO pin is clocked into a shift register on each rising edge of the SCK signal. On the rising edge of the CS* signal, the register is sent from the shift register to the register addressed. A slew rate of at least 30 V/ μ s is recommended for these signals. After programming is complete the CS* signal should be returned to a high state. If the SCK or SDIO lines are toggled while the VCO is in lock, as is sometimes the case when these lines are shared with other parts, the phase noise may be degraded during this programming.

4 wire mode read back has same timing as SDIO pin.

R/W bit = 0 is for SPI write. R/W bit = 1 is for SPI read.

W1 and W0 will be written as 0.

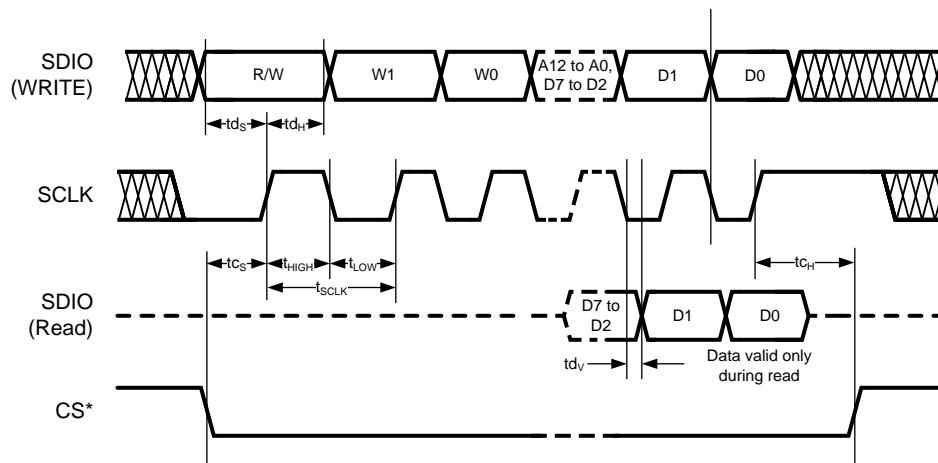

Figure 1. SPI Timing Diagram

LMK04821, LMK04826, LMK04828

SNAS605AR –MARCH 2013–REVISED DECEMBER 2015

www.ti.com

7.7 Typical Characteristics – Clock Output AC Characteristics

NOTE: These plots show performance at frequencies beyond the point at which the part is ensured to operate in order to give an idea of the capabilities of the part. They do not imply any sort of ensured specification.

For Figure 2 through Figure 7, CLKout2_3_IDL=1; CLKout2_3_ODL=0; LVPECL20 with 240-Ω emitter resistors; DCLKout2 Frequency = 245.76 MHz; DCLKout2_MUX = 0 (Divider). For Figure 2 through Figure 5, Balun Prodyn BIB-100G. For Figure 6 and Figure 7, Balun ADT2-1T+.

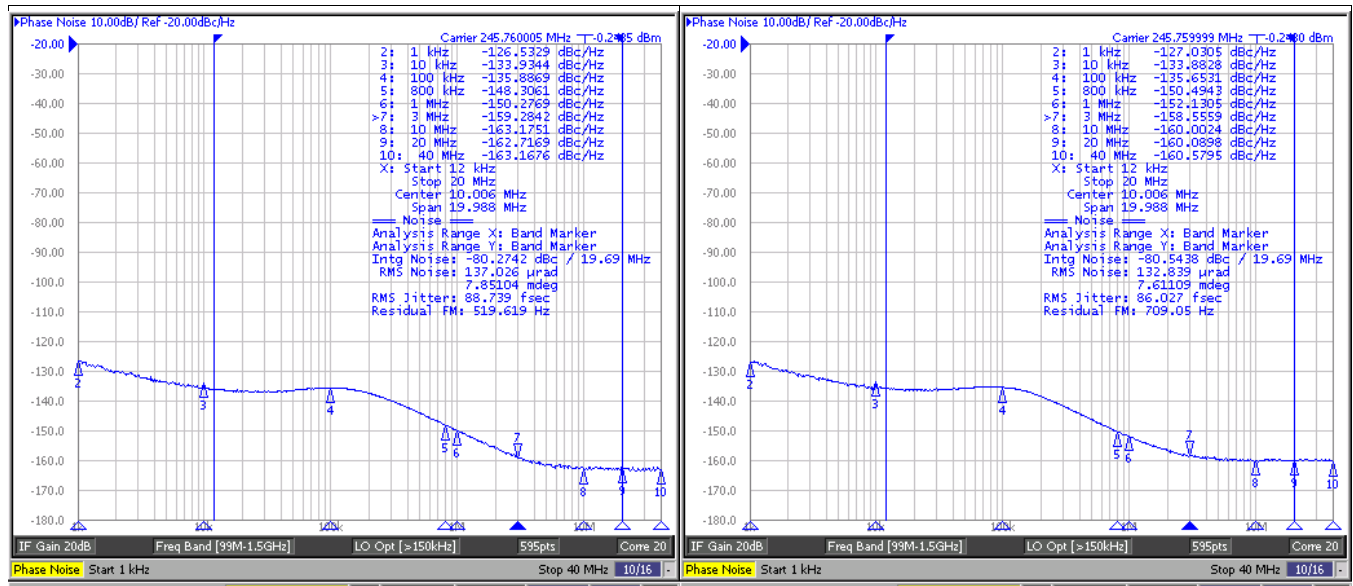

Figure 2. LMK04821 DCLKout2 Phase Noise
 VCO_MUX = 0 (VCO0) PLL2 Loop Filter Bandwidth = 288 kHz
 VCO0 = 1966.08 MHz PLL2 Phase Margin = 72°
 DCLKout2_DIV = 8

Figure 3. LMK04821 DCLKout2 Phase Noise
 VCO_MUX = 1 (VCO1) VCO1_DIV = 0 (≠2)
 VCO = 2949.12 MHz PLL2 Loop Filter Bandwidth = 221 kHz
 DCLKout2_DIV = 6 PLL2 Phase Margin = 70°

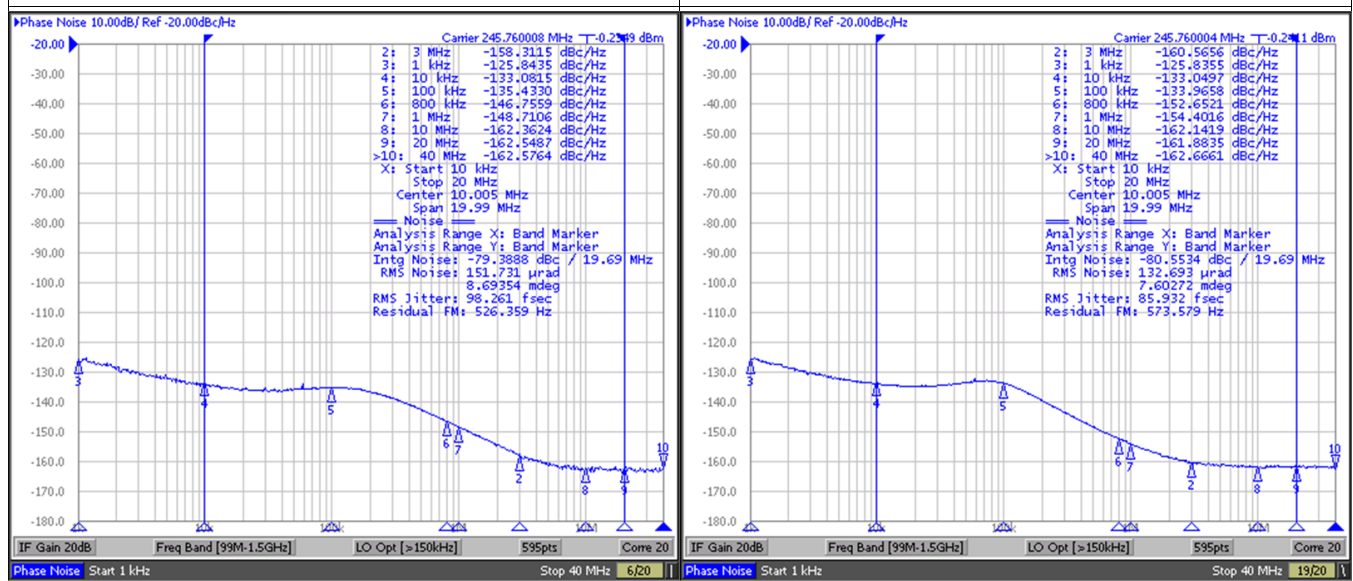

Figure 4. LMK04826B DCLKout2 Phase Noise
 VCO_MUX = 0 (VCO0) PLL2 Loop Filter Bandwidth = 303 kHz
 VCO0 = 1966.08 MHz PLL2 Phase Margin = 73°
 DCLKout2_DIV = 8

Figure 5. LMK04826B DCLKout2 Phase Noise
 VCO_MUX = 1 (VCO1) PLL2 Loop Filter Bandwidth = 151 kHz
 VCO = 2457.6 MHz PLL2 Phase Margin = 64°
 DCLKout2_DIV = 10

Typical Characteristics – Clock Output AC Characteristics (continued)

NOTE: These plots show performance at frequencies beyond the point at which the part is ensured to operate in order to give an idea of the capabilities of the part. They do not imply any sort of ensured specification.

For Figure 2 through Figure 7, CLKout2_3_IDL=1; CLKout2_3_ODL=0; LVPECL20 with 240-Ω emitter resistors; DCLKout2 Frequency = 245.76 MHz; DCLKout2_MUX = 0 (Divider). For Figure 2 through Figure 5, Balun Prodyn BIB-100G. For Figure 6 and Figure 7, Balun ADT2-1T+.

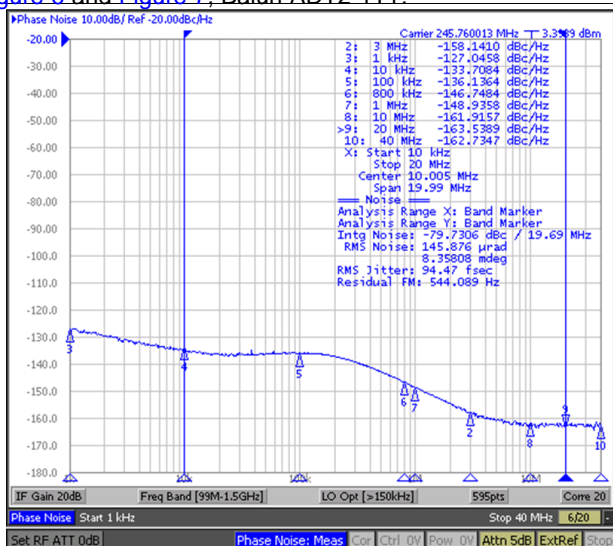

VCO_MUX = 0 (VCO0) PLL2 Loop Filter Bandwidth = 344 kHz
 VCO0 = 2457.6 MHz PLL2 Phase Margin = 73°
 DCLKout2_DIV = 10

Figure 6. LMK04828B DCLKout2 Phase Noise

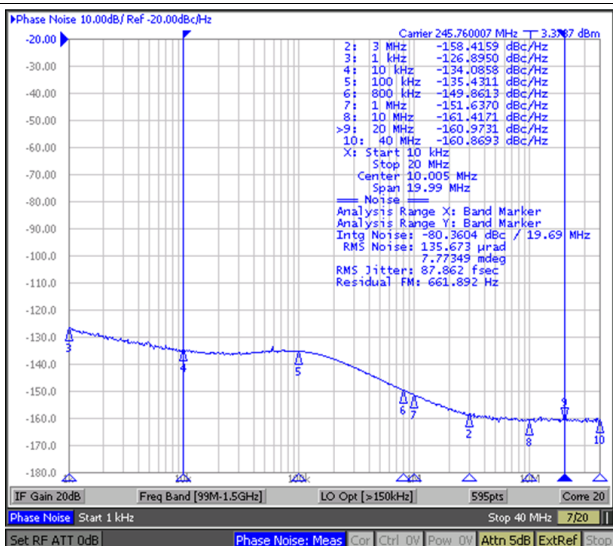

VCO_MUX = 1 (VCO1) PLL2 Loop Filter Bandwidth = 233 kHz
 VCO = 2949.12 MHz PLL2 Phase Margin = 70°
 DCLKout2_DIV = 12

Figure 7. LMK04828B DCLKout2 Phase Noise

8 Parameter Measurement Information

8.1 Charge Pump Current Specification Definitions

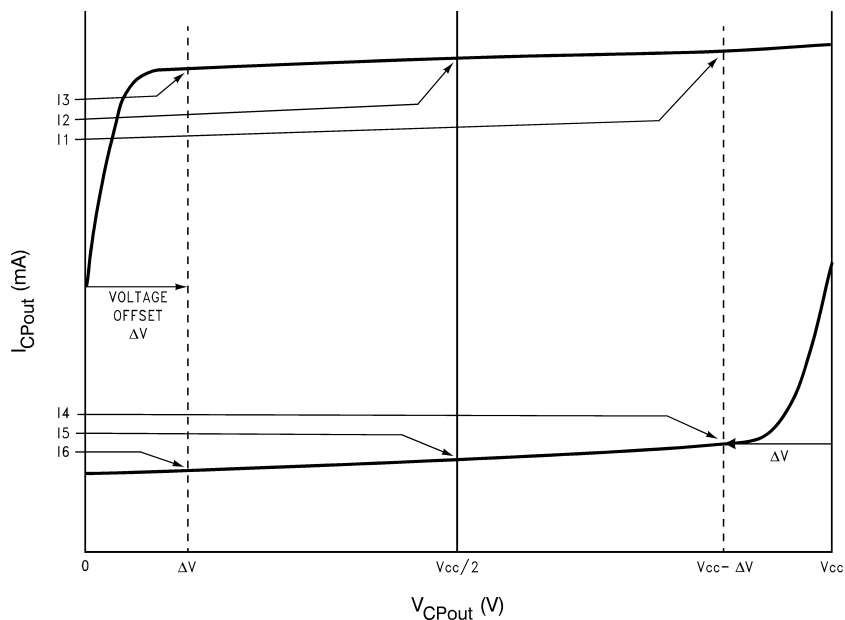

11 = Charge Pump Sink Current at $V_{CPout} = V_{CC} - \Delta V$

12 = Charge Pump Sink Current at $V_{CPout} = V_{CC}/2$

13 = Charge Pump Sink Current at $V_{CPout} = \Delta V$

14 = Charge Pump Source Current at $V_{CPout} = V_{CC} - \Delta V$

15 = Charge Pump Source Current at $V_{CPout} = V_{CC}/2$

16 = Charge Pump Source Current at $V_{CPout} = \Delta V$

ΔV = Voltage offset from the positive and negative supply rails. Defined to be 0.5 V for this device.

8.1.1 Charge Pump Output Current Magnitude Variation Vs. Charge Pump Output Voltage

$$I_{CPout} \text{ Vs } V_{CPout} = \frac{|11| - |13|}{|11| + |13|} \times 100\%$$

$$= \frac{|14| - |16|}{|14| + |16|} \times 100\%$$

8.1.2 Charge Pump Sink Current Vs. Charge Pump Output Source Current Mismatch

$$I_{CPout} \text{ Sink Vs } I_{CPout} \text{ Source} = \frac{|12| - |15|}{|12| + |15|} \times 100\%$$

8.1.3 Charge Pump Output Current Magnitude Variation Vs. Ambient Temperature

$$I_{CPout} \text{ Vs } T_A = \frac{|12|_{T_A} - |12|_{T_A=25^\circ\text{C}}}{|12|_{T_A=25^\circ\text{C}}} \times 100\%$$

$$= \frac{|15|_{T_A} - |15|_{T_A=25^\circ\text{C}}}{|15|_{T_A=25^\circ\text{C}}} \times 100\%$$

8.2 Differential Voltage Measurement Terminology

The differential voltage of a differential signal can be described by two different definitions causing confusion when reading data sheets or communicating with other engineers. This section will address the measurement and description of a differential signal so that the reader will be able to understand and distinguish between the two different definitions when used.

The first definition used to describe a differential signal is the absolute value of the voltage potential between the inverting and non-inverting signal. The symbol for this first measurement is typically V_{ID} or V_{OD} depending on if an input or output voltage is being described.

The second definition used to describe a differential signal is to measure the potential of the non-inverting signal with respect to the inverting signal. The symbol for this second measurement is V_{SS} and is a calculated parameter. Nowhere in the IC does this signal exist with respect to ground, it only exists in reference to its differential pair. V_{SS} can be measured directly by oscilloscopes with floating references, otherwise this value can be calculated as twice the value of V_{OD} as described in the first description.

Figure 8 illustrates the two different definitions side-by-side for inputs and Figure 9 illustrates the two different definitions side-by-side for outputs. The V_{ID} and V_{OD} definitions show V_A and V_B DC levels that the non-inverting and inverting signals toggle between with respect to ground. V_{SS} input and output definitions show that if the inverting signal is considered the voltage potential reference, the non-inverting signal voltage potential is now increasing and decreasing above and below the non-inverting reference. Thus the peak-to-peak voltage of the differential signal can be measured.

V_{ID} and V_{OD} are often defined as volts (V) and V_{SS} is often defined as volts peak-to-peak (V_{PP}).

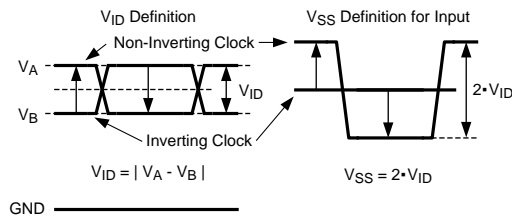

Figure 8. Two Different Definitions for Differential Input Signals

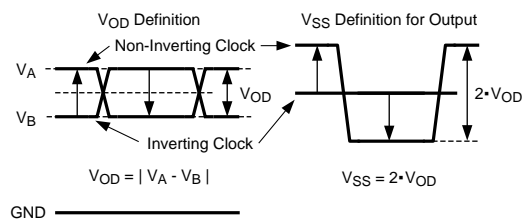

Figure 9. Two Different Definitions for Differential Output Signals

Refer to application note *AN-912 Common Data Transmission Parameters and their Definitions (SNLA036)* for more information.

9 Detailed Description

9.1 Overview

The family of LMK0482x devices are verify flexible to meet many application requirements. The typical use case for LMK0482x is as a cascaded dual loop jitter cleaner for JESD204B systems. However traditional (non-JESD204B) systems are possible with use of the large SYSREF divider to produce a low frequency. Note that while the Device Clock outputs (DCLKoutX) do not provide LVCMOS outputs, the OSCout may be used to provide LVCMOS outputs at DCLKout6 or DCLKout8 frequency using the feedback mux.

In addition to dual loop operation, by powering down various blocks the LMK0482x may be configured for single loop or clock distribution modes also.

9.1.1 Jitter Cleaning

The dual loop PLL architecture of the LMK0482x family provides the lowest jitter performance over a wide range of output frequencies and phase noise integration bandwidths. The first stage PLL (PLL1) is driven by an external reference clock and uses an external VCXO or tunable crystal to provide a frequency accurate, low phase noise reference clock for the second stage frequency multiplication PLL (PLL2).

PLL1 typically uses a narrow loop bandwidth (typically 10 Hz to 200 Hz) to retain the frequency accuracy of the reference clock input signal while at the same time suppressing the higher offset frequency phase noise that the reference clock may have accumulated along its path or from other circuits. This “cleaned” reference clock provides the reference input to PLL2.

The low phase noise reference provided to PLL2 allows PLL2 to operate with a wide loop bandwidth (typically 50 kHz to 200 kHz). The loop bandwidth for PLL2 is chosen to take advantage of the superior high offset frequency phase noise profile of the internal VCO and the good low offset frequency phase noise of the reference VCXO or tunable crystal.

Ultra low jitter is achieved by allowing the external VCXO or Crystal’s phase noise to dominate the final output phase noise at low offset frequencies and the internal VCO’s phase noise to dominate the final output phase noise at high offset frequencies. This results in best overall phase noise and jitter performance.

9.1.2 JEDEC JESD204B Support

The LMK0482x family provides support for JEDEC JESD204B. The LMK0482x will clock up to 7 JESD204B targets using 7 device clocks (DCLKoutX) and 7 SYSREF clocks (SDCLKoutY). Each device clock is grouped with a SYSREF clock.

It is also possible to re-program SYSREF clocks to behave as extra device clocks for applications which have non-JESD204B clock requirements.

9.1.3 Three PLL1 Redundant Reference Inputs (CLKin0/CLKin0*, CLKin1/CLKin1*, and CLKin2/CLKin2*)

The LMK0482x family has up to three reference clock inputs for PLL1. They are CLKin0, CLKin1, and CLKin2. The active clock is chosen based on CLKin_SEL_MODE. Automatic or manual switching can occur between the inputs.

CLKin0, CLKin1, and CLKin2 each have their own PLL1 R dividers.

CLKin1 is shared for use as an external 0-delay feedback (FBCLKin), or for use with an external VCO (Fin).

CLKin2 is shared for use as OSCout. To use powerdown OSCout, see [VCO_MUX](#), [OSCout_MUX](#), [OSCout_FMT](#).

Fast manual switching between reference clocks is possible with a external pins CLKin_SEL0 and CLKin_SEL1.

9.1.4 VCXO/Crystal Buffered Output

The LMK0482x family provides OSCout, which by default is a buffered copy of the PLL1 feedback/PLL2 reference input. This reference input is typically a low noise VCXO or Crystal. When using a VCXO, this output can be used to clock external devices such as microcontrollers, FPGAs, CPLDs, and so forth, before the LMK0482x is programmed.

The OSCout buffer output type is programmable to LVDS, LVPECL, or LVCMOS.

Overview (continued)

The VCXO/Crystal buffered output can be synchronized to the VCO clock distribution outputs by using Cascaded 0-Delay Mode. The buffered output of VCXO/Crystal has deterministic phase relationship with CLKIn.

9.1.5 Frequency Holdover

The LMK0482x family supports holdover operation to keep the clock outputs on frequency with minimum drift when the reference is lost until a valid reference clock signal is re-established.

9.1.6 PLL2 Integrated Loop Filter Poles

The LMK0482x family features programmable 3rd and 4th order loop filter poles for PLL2. These internal resistors and capacitor values may be selected from a fixed range of values to achieve either a 3rd or 4th order loop filter response. The integrated programmable resistors and capacitors compliment external components mounted near the chip.

These integrated components can be effectively disabled by programming the integrated resistors and capacitors to their minimum values.

9.1.7 Internal VCOs

The LMK0482x family has two internal VCOs, selected by VCO_MUX. The output of the selected VCO is routed to the Clock Distribution Path. This same selection is also fed back to the PLL2 phase detector through a prescaler and N-divider.

9.1.8 VCO1 Divider (LMK04821 only)

The LMK04821 includes a VCO divider on the output of VCO1. The VCO1 divider can be programmed from 2 to 8.

When using a VCO1 frequency of 2949.12 MHz and a divide of 8, frequencies as low as 11.52 MHz can be achieved. Using the VCO1_DIV will limit maximum output frequency from any output to VCO1 frequency divided by VCO1_DIV value.

When using VCO1, the output frequency from the VCO1_DIV will define digital delay resolution.

The VCO1_DIV divider also impacts the total N divide value for PLL2 when VCO1 is selected, this should be accounted for when selecting PLL2_N value.

9.1.9 External VCO Mode

The Fin/Fin* input allows an external VCO to be used with PLL2 of the LMK0482x family.

Using an external VCO reduces the number of available clock inputs by one.

9.1.10 Clock Distribution

The LMK0482x family features a total of 14 PLL2 clock outputs driven from the internal or external VCO.

All PLL2 clock outputs have programmable output types. They can be programmed to LVPECL, LVDS, or HSDS, or LCPECL.

If OSCOut is included in the total number of clock outputs the LMK0482x family is able to distribute, then up to 15 differential clocks. OSCOut may be a buffered version of OSCIn, DCLKout6, DCLKout8, or SYSREF.

The following sections discuss specific features of the clock distribution channels that allow the user to control various aspects of the output clocks.

9.1.10.1 Device Clock Divider

Each device clock, DCLKoutX, has a single clock output divider. The divider supports a divide range of 1 to 32 (even and odd) with 50% output duty cycle using duty cycle correction mode. The output of this divider may also be directed to SDCLKoutY, where $Y = X + 1$.

Overview (continued)

9.1.10.2 Sysref Clock Divider

The SYSREF clocks, SDCLKoutY, all share a common divider. The divider supports a divide range of 8 to 8191 (even and odd).

9.1.10.3 Device Clock Delay

The device clocks include both an analog and digital delay for phase adjustment of the clock outputs.

The analog delay allows a nominal 25 ps step size and range from 0 to 575 ps of total delay. Enabling the analog delay adds a nominal 500 ps of delay in addition to the programmed value.

The digital delay allows a group of outputs to be delayed from 4 to 32 VCO cycles. The delay step can be as small as half the period of the clock distribution path. For example, 2 GHz VCO frequency results in 250 ps coarse tuning steps. The coarse (digital) delay value takes effect on the clock outputs after a SYNC event.

There are 2 different ways to use the digital delay.

1. Fixed Digital Delay - Allows all the outputs to have a known phase relationship upon a SYNC event. Typically performed at startup.
2. Dynamic Digital Delay - Allows the phase relationships of clocks to change while clocks continue to operate.

9.1.10.4 SYSREF Delay

The global SYSREF divider includes a digital delay block which allows a global phase shift with respect to the other clocks.

Each local SYSREF clock output includes both an analog and additional local digital delay for unique phase adjustment of each SYSREF clock.

The local analog delay allows for 150 ps steps.

The local digital delay and SYSREF_HS bit allows the each individual SYSREF output to be delayed from, 1.5 to 11 VCO cycles. The delay step can be as small as half the period of the clock distribution path by using the DCLKoutX_HS bit. For example, 2 GHz VCO frequency results in 250 ps coarse tuning steps.

9.1.10.5 Glitchless Half Step and Glitchless Analog Delay

The device clocks include a features to ensure glitchless operation of the half step and analog delay operations when enabled.

9.1.10.6 Programmable Output Formats

For increased flexibility all LMK0482x family device and SYSREF clock outputs, DCLKoutX and SDCLKoutY, can be programmed to an LVDS, HSDS, LVPECL, or LCPECL output type. The OSCout can be programmed to an LVDS, LVPECL, or LVCMOS output type.

Any LVPECL output type can be programmed to 1600, or 2000 mVpp amplitude levels. The 2000 mVpp LVPECL output type is a Texas Instruments proprietary configuration that produces a 2000 mVpp differential swing for compatibility with many data converters and is also known as 2VPECL.

LCPECL allows for DC coupling SYSREF to low voltage converters.

9.1.10.7 Clock Output Synchronization

Using the SYNC input causes all active clock outputs to share a rising edge as programmed by fixed digital delay.

The SYNC event must occur for digital delay values to take effect.

Overview (continued)

9.1.11 0-Delay

The LMK0482x family supports two types of 0-delay.

1. Cascaded 0-delay
2. Nested 0-delay

Cascaded 0-delay mode establishes a fixed deterministic phase relationship of the phase of the PLL2 input clock (OSCin) to the phase of a clock selected by the feedback mux. The 0-delay feedback may be performed with an internal feedback from CLKout6, CLKout8, SYSREF, or with an external feedback loop into the FBCLKin port as selected by the FB_MUX. Because OSCin has a fixed deterministic phase relationship to the feedback clock, OSCout will also have a fixed deterministic phase relationship to the feedback clock. In this mode PLL1 input clock (CLKinX) also has a fixed deterministic phase relationship to PLL2 input clock (OSCin), this results in a fixed deterministic phase relationship between all clocks from CLKinX to the clock outputs.

Nested 0-delay mode establishes a fixed deterministic phase relationship of the phase of the PLL1 input clock (CLKinX) to the phase of a clock selected by the feedback mux. The 0-delay feedback may be performed with an internal feedback from CLKout6, CLKout8, SYSREF, or with an external feedback loop into the FBCLKin port as selected by the FB_MUX.

Without using 0-delay mode there will be n possible fixed phase relationships from clock input to clock output depending on the clock output divide value.

Using an external 0-delay feedback reduces the number of available clock inputs by one.

9.1.12 Status Pins

The LMK0482x provides status pins which can be monitored for feedback or in some cases used for input depending upon device programming. For example:

- The CLKin_SEL0 pin may indicate the LOS (loss-of-signal) for CLKin0.
- The CLKin_SEL1 pin may be an input for selecting the active clock input.
- The Status_LD1 pin may indicate if the device is locked.
- The Status_LD2 pin may indicate if PLL2 is locked.

The status pins can be programmed to a variety of other outputs including PLL divider outputs, combined PLL lock detect signals, PLL1 Vtune railing, readback, and so forth. Refer to the programming section of this data sheet for more information.

9.2 Functional Block Diagram

Figure 10 and Figure 11 illustrate the complete LMK0482x family block diagram.

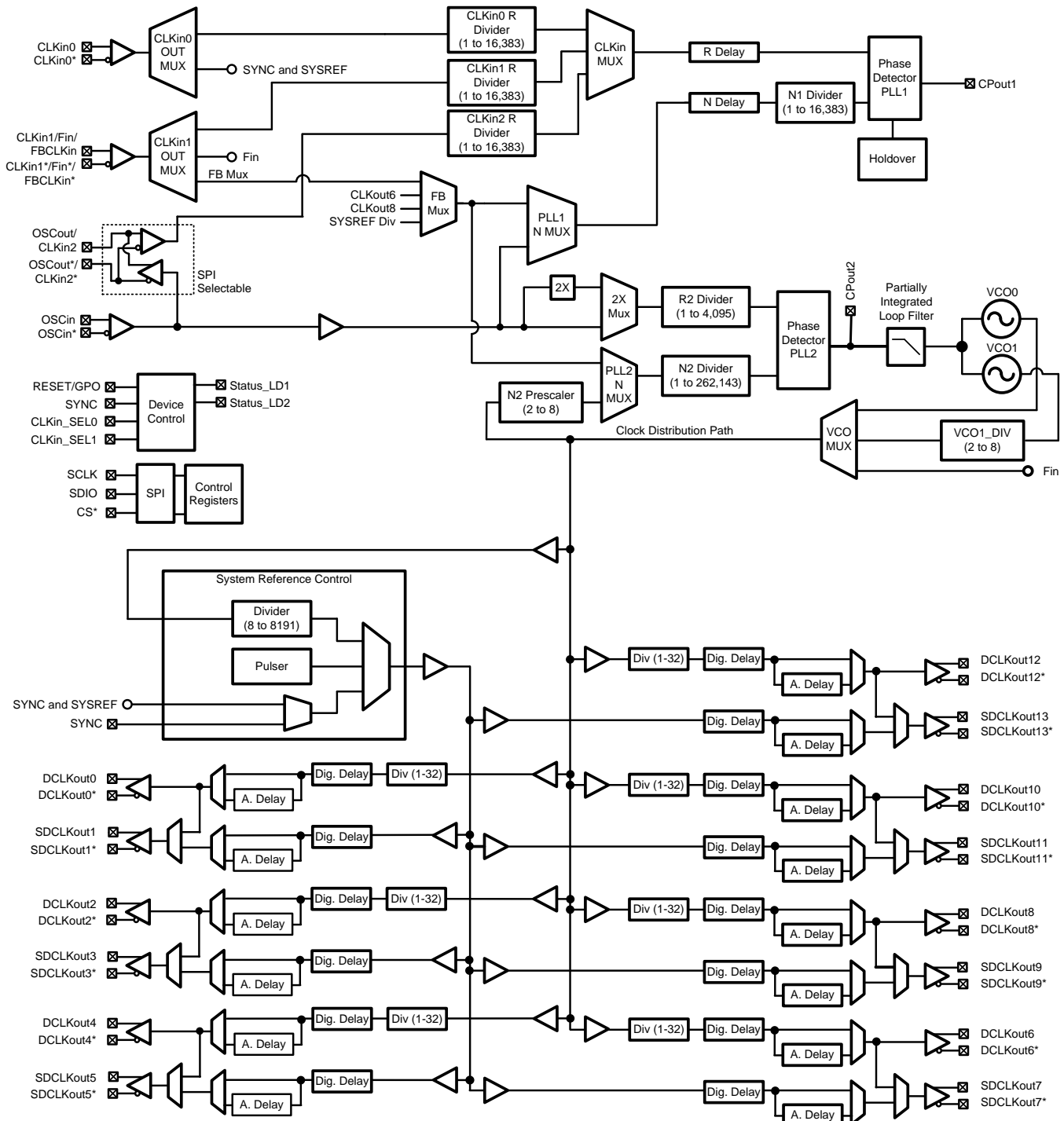

Figure 10. Detailed LMK04821 Block Diagram

Functional Block Diagram (continued)

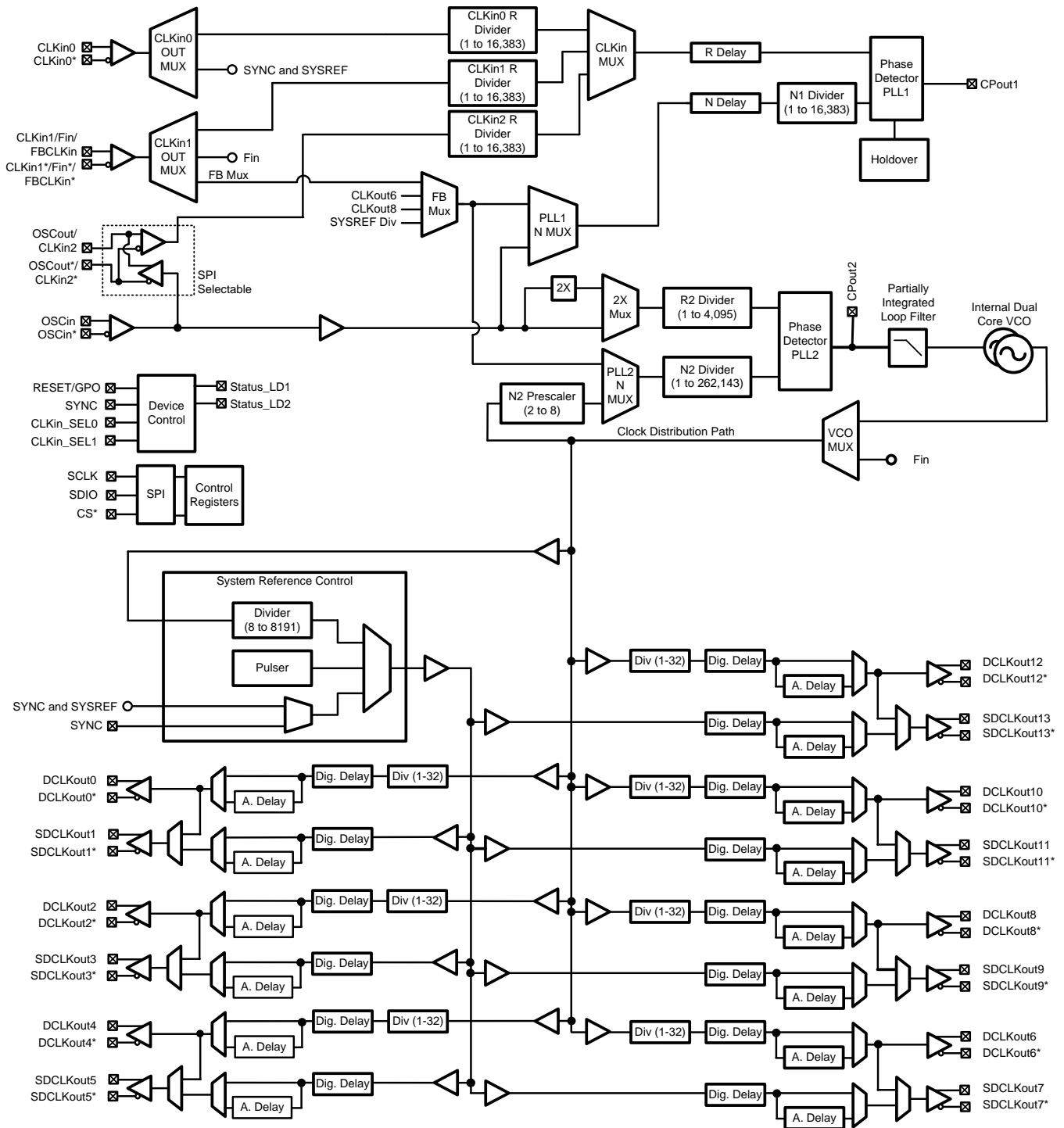

Figure 11. Detailed LMK04826 and LMK04828 Block Diagram

Functional Block Diagram (continued)

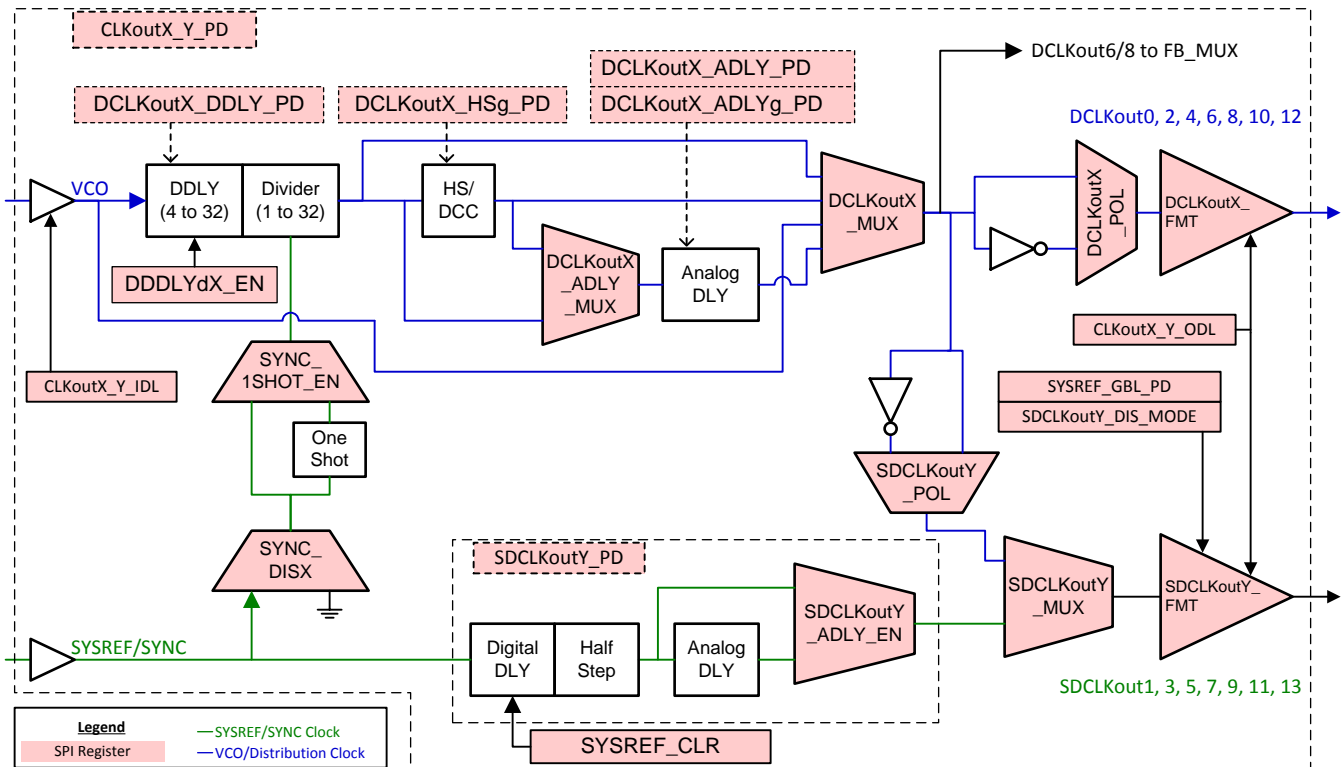

Figure 12. Device and SYSREF Clock Output Block

Functional Block Diagram (continued)

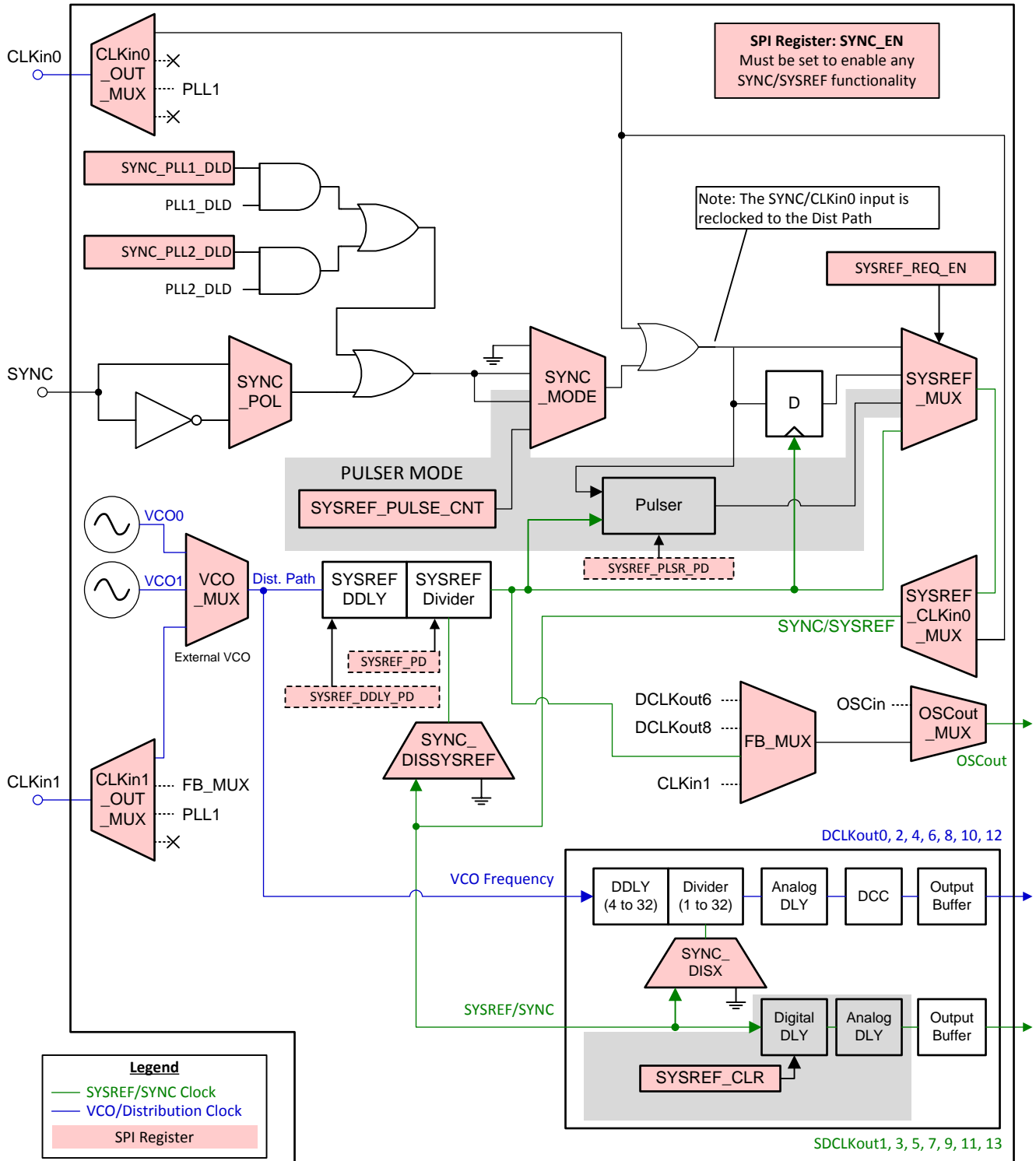

Figure 13. SYNC/SYSREF Clocking Paths

9.3 Feature Description

9.3.1 SYNC/SYSREF

The SYNC and SYSREF signals share the same clocking path. To properly use SYNC and/or SYSREF for JESD204B it is important to understand the SYNC/SYSREF system. [Figure 12](#) illustrates the detailed diagram of a clock output block with SYNC circuitry included. [Figure 13](#) illustrates the interconnects and highlights some important registers used in controlling the device for SYNC/SYSREF purposes.

To reset or synchronize a divider, the following conditions must be met:

1. SYNC_EN must be set. This ensures proper operation of the SYNC circuitry.
2. SYSREF_MUX and SYNC_MODE must be set to a proper combination to provide a valid SYNC/SYSREF signal.
 - If SYSREF block is being used, the SYSREF_PD bit must be clear.
 - If the SYSREF Pulser is being used, the SYSREF_PLSR_PD bit must be clear.
 - For each SDCLKoutY being used for SYSREF, respective SDCLKoutY_PD bits must be cleared.
3. SYSREF_DDLY_PD and DCLKoutX_DDLY_PD bits must be clear to power up the digital delay circuitry during SYNC as use requires.
4. The SYNC_DISX bit must be clear to allow SYNC/SYSREF signal to divider circuit. The SYSREF_MUX register selects the SYNC source which resets the SYSREF/CLKoutX dividers provided the corresponding SYNC_DISX bit is clear.
5. Other bits which impact the operation of SYNC such as SYNC_1SHOT_EN may be set as desired.

[Table 1](#) illustrates the some possible combinations of SYSREF_MUX and SYNC_MODE.

Table 1. Some Possible SYNC Configurations

NAME	SYNC_MODE	SYSREF_MUX	OTHER	DESCRIPTION
SYNC Disabled	0	0	CLKin0_OUT_MUX ≠ 0	No SYNC will occur.
Pin or SPI SYNC	1	0	CLKin0_OUT_MUX ≠ 0	Basic SYNC functionality, SYNC pin polarity is selected by SYNC_POL. To achieve SYNC through SPI, toggle the SYNC_POL bit.
Differential input SYNC	0 or 1	0 or 1	CLKin0_OUT_MUX = 0	Differential CLKin0 now operates as SYNC input.
JESD204B Pulser on pin transition.	2	2	SYSREF_PULSE_CNT sets pulse count	Produce SYSREF_PULSE_CNT programmed number of pulses on pin transition. SYNC_POL can be used to cause SYNC via SPI.
JESD204B Pulser on SPI programming.	3	2	SYSREF_PULSE_CNT sets pulse count	Programming SYSREF_PULSE_CNT register starts sending the number of pulses.
Re-clocked SYNC	1	1	SYSREF operational, SYSREF Divider as required for training frame size.	Allows precise SYNC for n-bit frame training patterns for non-JESD converters such as LM97600.
External SYSREF request	0	2	SYSREF_REQ_EN = 1 Pulser powered up	When SYNC pin is asserted, continuous SYSREF pulses occur. Turning on and off of the pulses is synchronized to prevent runt pulses from occurring on SYSREF.
Continuous SYSREF	X	3	SYSREF_PD = 0 SYSREF_DDLY_PD = 0 SYSREF_PLSR_PD = 1 (1)	Continuous SYSREF signal.

(1) SDCLKoutY_PD = 0 as required per SYSREF output. This applies to any SYNC or SYSREF output on SDCLKoutY when SDCLKoutY_MUX = 1 (SYSREF output)

Feature Description (continued)

Table 1. Some Possible SYNC Configurations (continued)

NAME	SYNC_MODE	SYSREF_MUX	OTHER	DESCRIPTION
Direct SYSREF distribution	0	0	CLKin0_OUT_MUX = 0 SDCLKoutY_DDLY = 0 (Local sysref DDLY bypassed) SYSREF_DDLY_PD = 1 SYSREF_PLSR_PD = 1 SYSREF_PD = 1.	A direct fan-out of SYSREF with no re-clocking to clock distribution path.

9.3.2 JEDEC JESD204B

9.3.2.1 How To Enable SYSREF

Table 2 summarizes the bits needed to make SYSREF functionality operational.

Table 2. SYSREF Bits

REGISTER	FIELD	VALUE	DESCRIPTION
0x140	SYSREF_PD	0	Must be clear, power-up SYSREF circuitry.
0x140	SYSREF_DDLY_PD	0	Must be clear to power-up digital delay circuitry during initial SYNC to ensure deterministic timing.
0x143	SYNC_EN	1	Must be set, enable SYNC.
0x143	SYSREF_CLR	1 → 0	Do not hold local SYSREF DDLY block in reset except at start. Anytime SYSREF_PD = 1 because of user programming or device RESET, it is necessary to set SYSREF_CLR for 15 VCO clock cycles to clear the local SYSREF digital delay. Once cleared, SYSREF_CLR must be cleared to allow SYSREF to operate.

Enabling JESD204B operation involves synchronizing all the clock dividers with the SYSREF divider, then configuring the actual SYSREF functionality.

9.3.2.1.1 Setup of SYSREF Example

The following procedure is a programming example for a system which is to operate with a 3000 MHz VCO frequency. Use DCLKout0 and DCLKout2 to drive converters at 1500 MHz. Use DCLKout4 to drive an FPGA at 150 MHz. Synchronize the converters and FPGA using a two SYSREF pulses at 10 MHz.

1. Program registers 0x000 to 0x1fff as desired. Key to prepare for SYSREF operations:

- Prepare for manual SYNC: SYNC_POL = 0, SYNC_MODE = 1, SYSREF_MUX = 0
- Setup output dividers as per example: DCLKout0_DIV and DCLKout2_DIV = 2 for frequency of 1500 MHz. DCLKout4_DIV = 20 for frequency of 150 MHz.
- Setup output dividers as per example: SYSREF_DIV = 300 for 10 MHz SYSREF
- Setup SYSREF: SYSREF_PD = 0, SYSREF_DDLY_PD = 0, DCLKout0_DDLY_PD = 0, DCLKout2_DDLY_PD = 0, DCLKout4_DDLY_PD = 0, SYNC_EN = 1, SYSREF_PLSR_PD = 0, SYSREF_PULSE_CNT = 1 (2 pulses). SDCLKout1_PD = 0, SDCLKout3_PD = 0
- Clear Local SYSREF DDLY: SYSREF_CLR = 1.

2. Establish deterministic phase relationships between SYSREF and Device Clock for JESD204B:

- Set device clock and SYSREF divider digital delays: DCLKout0_DDLY_CNTH, DCLKout0_DDLY_CNTL, DCLKout2_DDLY_CNTH, DCLKout2_DDLY_CNTL, DCLKout4_DDLY_CNTH, DCLKout4_DDLY_CNTL, SYSREF_DDLY.
- Set device clock digital delay half steps: DCLKout0_HS, DCLKout2_HS, DCLKout4_HS.
- Set SYSREF clock digital delay as required to achieve known phase relationships: SDCLKout1_DDLY, SDCLKout3_DDLY, SDCLKout5_DDLY.
- To allow SYNC to effect dividers: SYNC_DIS0 = 0, SYNC_DIS2 = 0, SYNC_DIS4 = 0, SYNC_DISSYSREF = 0
- Perform SYNC by toggling SYNC_POL = 1 then SYNC_POL = 0.

3. Now that dividers are synchronized, **disable SYNC from resetting these dividers**. It is not desired for SYSREF to reset its own divider or the dividers of the output clocks.
 - (a) Prevent SYNC (SYSREF) from affecting dividers: SYNC_DIS0 = 1, SYNC_DIS2 = 1, SYNC_DIS4 = 1, SYNC_DISSYSREF = 1.
4. **Release reset of local SYSREF digital delay**.
 - (a) SYSREF_CLR = 0. Note this bit needs to be set for only 15 VCO clocks after SYSREF_PD = 0.
5. **Set SYSREF operation**.
 - (a) Allow pin SYNC event to start pulser: SYNC_MODE = 2.
 - (b) Select pulser as SYSREF signal: SYSREF_MUX = 2.
6. **Complete!** Now asserting the SYNC pin, or toggling SYNC_POL will result in a series of 2 SYSREF pulses.

9.3.2.1.2 SYSREF_CLR

The local digital delay of the SDCLKout is implemented as a shift buffer. To ensure no un-wanted pulses occur at this SYSREF output at startup, when using SYSREF, requires clearing the buffers by setting SYSREF_CLR = 1 for 15 VCO clock cycles. After a reset, this bit is set, so it must be cleared before SYSREF output is used.

9.3.2.2 SYSREF Modes

9.3.2.2.1 SYSREF Pulser

This mode allows for the output of 1, 2, 4, or 8 SYSREF pulses for every SYNC pin event or SPI programming. This implements the gapped periodic functionality of the JEDEC JESD204B specification.

When in SYSREF Pulser mode, programming the field SYSREF_PULSE_CNT in register 0x13E will result in the pulser sending the programmed number of pulses.

9.3.2.2.2 Continuous SYSREF

This mode allows for continuous output of the SYSREF clock.

Continuous operation of SYSREF is not recommended due to crosstalk from the SYSREF clock to device clock. JESD204B is designed to operate with a single burst of pulses to initialize the system at startup, after which it is theoretically not required to send another SYSREF since the system will continue to operate with deterministic phases.

If continuous operation of SYSREF is required, consider using a SYSREF output from a non-adjacent output or SYSREF from the OSCout pin to minimize crosstalk.

9.3.2.2.3 SYSREF Request

This mode allows an external source to synchronously turn on or off a continuous stream of SYSREF pulses using the SYNC/SYSREF_REQ pin.

Setup the mode by programming SYSREF_REQ_EN = 1 and SYSREF_MUX = 2 (Pulser). The pulser does not need to be powered for this mode of operation.

When the SYSREF_REQ pin is asserted, the SYSREF_MUX will synchronously be set to continuous mode providing continuous pulses at the SYSREF frequency until the SYSREF_REQ pin is un-asserted and the final SYSREF pulse will complete sending synchronously.

9.3.3 Digital Delay

Digital (coarse) delay allows a group of outputs to be delayed by 4 to 32 VCO cycles. The delay step can be as small as half the period of the VCO cycle by using the DCLKoutX_HS bit. There are two different ways to use the digital delay:

1. Fixed digital delay
2. Dynamic digital delay

In both delay modes, the regular clock divider is substituted with an alternative divide value. The substitute divide value consists of two values, DCLKoutX_DDLY_CNTH and DCLKoutX_DDLY_CNTL. The minimum _CNTH/_CNTL value is 2 and the maximum _CNTH/_CNTL value is 16. This will result in a minimum alternative divide value of 4 and a maximum of 32.

9.3.3.1 Fixed Digital Delay

Fixed digital delay value takes effect on the clock outputs after a SYNC event. As such, the outputs will be LOW for a while during the SYNC event. Applications that cannot accept clock breakup when adjusting digital delay should use dynamic digital delay.

9.3.3.1.1 Fixed Digital Delay Example

Assuming the device already has the following initial configurations, and the application should delay DCLKout2 by one VCO cycle compared to DCLKout0.

- VCO frequency = 2949.12 MHz
- DCLKout0 = 368.64 MHz (DCLKout0_DIV = 8)
- DCLKout2 = 368.64 MHz (DCLKout2_DIV = 8)

The following steps should be followed

1. Set DCLKout0_DDLY_CNTH = 4 and DCLKout2_DDLY_CNTH = 4. First part of delay for each clock.
2. Set DCLKout0_DDLY_CNTL = 4 and DCLKout2_DDLY_CNTL = 5. Second part of delay for each clock.
3. Set DCLKout0_DDLY_PD = 0 and DCLKout2_DDLY_PD = 0. Power up the digital delay circuit.
4. Set SYNC_DIS0 = 0 and SYNC_DIS2 = 0. Allow the output to be synchronized.
5. Perform SYNC by asserting, then unasserting SYNC. Either by using SYNC_POL bit or the SYNC pin.
6. Now that the SYNC is complete, to save power it is allowable to power down DCLKout0_DDLY_PD = 1 and/or DCLKout2_DDLY_PD = 1.
7. Set SYNC_DIS0 = 1 and SYNC_DIS2 = 1. To prevent the output from being synchronized, very important for steady state operation when using JESD204B.

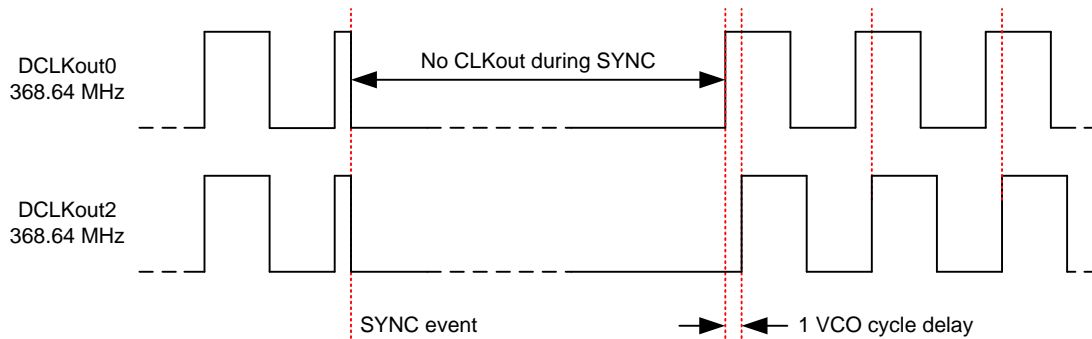

Figure 14. Fixed Digital Delay Example

9.3.3.2 Dynamic Digital Delay

Dynamic digital delay allows the phase of clocks to be changed with respect to each other with little impact to the clock signal. This is accomplished by substituting the regular clock divider with an alternate divide value for one cycle. This substitution will occur a number of times equal to the value programmed into the DDLYd_STEP_CNT field for all outputs with DDLYdX_EN = 1.

- By programming a larger alternate divider (delay) value, the phase of the adjusted outputs will be delayed with respect to the other clocks.
- By programming a smaller alternate divider (delay) value, the phase of the adjusted output will advanced with respect to the other clocks.

Table 3 shows the recommended DCLKoutX_DDLY_CNTH and DCLKoutX_DDLY_CNTL alternate divide setting for delay by one VCO cycle. The clock will output high during the DCLKoutX_DDLY_CNTH time to permit a continuous output clock. The clock output will be low during the DCLKoutX_DDLY_CNTL time.

Table 3. Recommended DCLKoutX_DDLY_CNTH/_CNTL Values for Delay by One VCO Cycle

CLOCK DIVIDER	_CNTH	_CNTL		CLOCK DIVIDER	_CNTH	_CNTL
2	2	3		17	9	9
3	3	4		18	9	10
4	2	3		19	10	10
5	3	3		20	10	11
6	3	4		21	11	11
7	4	4		22	11	12
8	4	5		23	12	12
9	5	5		24	12	13
10	5	6		25	13	13
11	6	6		26	13	14
12	6	7		27	14	14
13	7	7		28	14	15
14	7	8		29	15	15
15	8	8		30	15	16 ⁽¹⁾
16	8	9		31	16 ⁽¹⁾	16 ⁽¹⁾

(1) To achieve _CNTH/_CNTL value of 16, 0 must be programmed into the _CNTH/_CNTL field.

9.3.3.3 Single and Multiple Dynamic Digital Delay Example

In this example two separate adjustments will be made to the device clocks. In the first adjustment a single delay of 1 VCO cycle will occur between DCLKout2 and DCLKout0. In the second adjustment two delays of 1 VCO cycle will occur between DCLKout2 and DCLKout0. At this point in the example, DCLKout2 will be delayed 3 VCO cycles behind DCLKout0.

Assuming the device already has the following initial configurations:

- VCO frequency: 2949.12 MHz
- DCLKout0 = 368.64 MHz, DCLKout0_DIV = 8
- DCLKout2 = 368.64 MHz, DCLKout2_DIV = 8

The following steps illustrate the example above:

1. Set DCLKout2_DDLY_CNTH = 4. First part of delay for DCLKout2.
2. Set DCLKout2_DDLY_CNTL = 5. Second part of delay for DCLKout2.
3. Set DCLKout2_DDLY_PD = 0. Enable the digital delay for DCLKout2.
4. Set DDLYd2_EN = 1. Enable dynamic digital delay for DCLKout2.
5. Set SYNC_DIS0 = 1 and SYNC_DIS2 = 0. Sync should be disabled to DCLKout0, but not DCLKout2.
6. Set SYNC_MODE = 3. Enable SYNC event from SPI write to DDLYd_STEP_CNT's register.
7. Set SYNC_MODE = 2, SYSREF_MUX = 2. Setup proper SYNC settings.
8. Set DDLYd_STEP_CNT = 1. This begins the **first adjustment**.

Before step 8 DCLKout2 clock edge is aligned with DCLKout0.

After step 8, DCLKout2 counts four VCO cycles high and then five VCO cycles low as programmed by DCLKout2_DDLY_CNTH and DCLKout2_DDLY_CNTL fields, effectively delaying DCLKout2 by one VCO cycle with respect to DCLKout0. **This is the first adjustment.**

9. Set DDLYd_STEP_CNT = 2. This begins the **second adjustment**.

Before step 9, DCLKout2 clock edge was delayed 1 VCO cycle from DCLKout0.

After step 9, DCLKout2 counts four VCO cycles high and then five VCO cycles low as programmed by DCLKout2_DDLY_CNTH and DCLKout2_DDLY_CNTL fields twice, delaying DCLKout2 by two VCO cycles with respect to DCLKout0. **This is the second adjustment.**

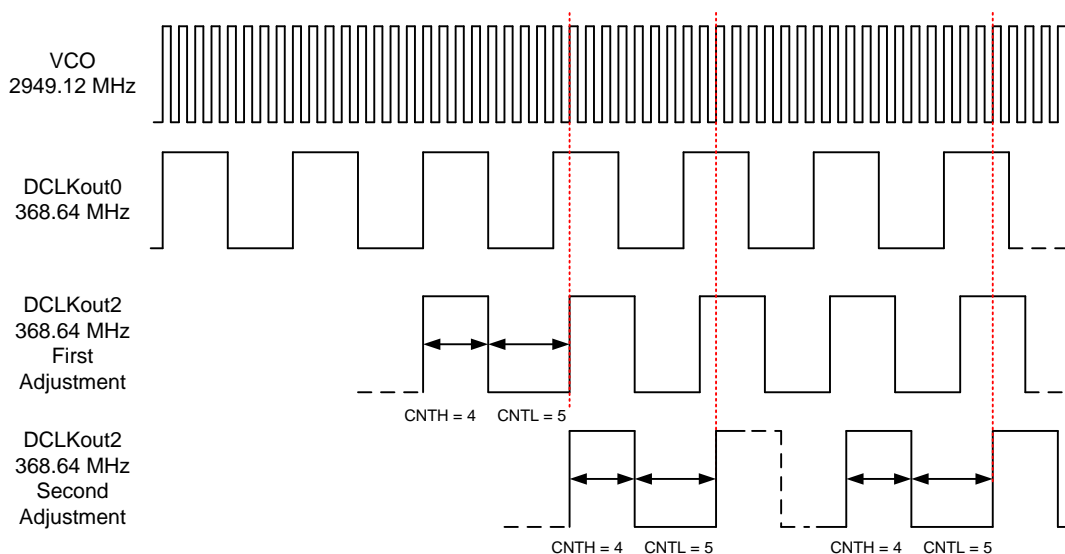

Figure 15. Single and Multiple Adjustment Dynamic Digital Delay Example

9.3.4 SYSREF to Device Clock Alignment

To ensure proper JESD204B operation, the timing relationship between the SYSREF and the Device clock must be adjusted for optimum setup and hold time. The $t_{s_{JESD204B}}$ defines the time between SYSREF and Device Clock for a specific condition of SYSREF divider and Device Clock digital delay. From this point, the SYSREF_DDLY, SDCLKoutY_DDLY, DCLKoutX_DDLY_CNTH, DCLKoutDDLY_CNTH, and DCLKoutX_MUX, SDCKLoutX_ADLY, and so forth, can be adjusted to provide the required setup and hold time between SYSREF and Device Clock.

It is possible to digitally adjust the SYSREF up to 20 VCO cycles before the SYSREF. So for example with a 2949.12 MHz VCO frequency, $t_{s_{JESD204B}} + 20 \times (1/\text{VCO Frequency}) = -80 \text{ ps} + 20 \times (1/2949.12 \text{ MHz}) = 6.7 \text{ ns}$.

9.3.5 Input Clock Switching

Manual, pin select, and automatic are three different kinds clock input switching modes can be set with the CLKin_SEL_MODE register.

Below is information about how the active input clock is selected and what causes a switching event in the various clock input selection modes.

9.3.5.1 Input Clock Switching - Manual Mode

When CLKin_SEL_MODE is 0, 1, or 2 then CLKin0, CLKin1, or CLKin2 respectively is always selected as the active input clock. Manual mode will also override the EN_CLKinX bits such that the CLKinX buffer will operate even if CLKinX is disabled with EN_CLKinX = 0.

If holdover is entered in this mode, then the device will re-lock to the selected CLKin upon holdover exit.

9.3.5.2 Input Clock Switching - Pin Select Mode

When CLKin_SEL_MODE is 3, the pins CLKin_SEL0 and CLKin_SEL1 select which clock input is active.

Configuring Pin Select Mode

The CLKin_SEL0_TYPE must be programmed to an input value for the CLKin_SEL0 pin to function as an input for pin select mode.

The CLKin_SEL1_TYPE must be programmed to an input value for the CLKin_SEL1 pin to function as an input for pin select mode.

If the CLKin_SELX_TYPE is set as output, the pin input value is considered "Low."

The polarity of CLKin_SEL0 and CLKin_SEL1 input pins can be inverted with the CLKin_SEL_INV bit.

[Table 4](#) defines which input clock is active depending on CLKin_SEL0 and CLKin_SEL1 state.

Table 4. Active Clock Input - Pin Select Mode, CLKin_SEL_INV = 0

PIN CLKin_SEL1	PIN CLKin_SEL0	ACTIVE CLOCK
Low	Low	CLKin0
Low	High	CLKin1
High	Low	CLKin2
High	High	Holdover

The pin select mode will override the EN_CLKinX bits such that the CLKinX buffer will operate even if CLKinX is disabled with EN_CLKinX = 0. To switch as fast as possible, keep the clock input buffers enabled (EN_CLKinX = 1) that could be switched to.

9.3.5.3 Input Clock Switching - Automatic Mode

When CLKin_SEL_MODE is 4, the active clock is selected in round-robin order of enabled clock inputs starting upon an input clock switch event. The switching order of the clocks is CLKin0 → CLKin1 → CLKin2 → CLKin0, and so forth.

For a clock input to be eligible to be switched through, it must be enabled using EN_CLKinX.

Starting Active Clock

Upon programming this mode, the currently active clock remains active if PLL1 lock detect is high. To ensure a particular clock input is the active clock when starting this mode, program CLKin_SEL_MODE to the manual mode which selects the desired clock input (CLKin0, 1, or 2). Wait for PLL1 to lock PLL1_DLD = 1, then select this mode with CLKin_SEL_MODE = 4.

9.3.6 Digital Lock Detect

Both PLL1 and PLL2 support digital lock detect. Digital lock detect compares the phase between the reference path (R) and the feedback path (N) of the PLL. When the time error, which is phase error, between the two signals is less than a specified window size (ϵ) a lock detect count increments. When the lock detect count reaches a user specified value, PLL1_DLD_CNT or PLL2_DLD_CNT, lock detect is asserted true. Once digital lock detect is true, a single phase comparison outside the specified window will cause digital lock detect to be asserted false. This is illustrated in [Figure 16](#).

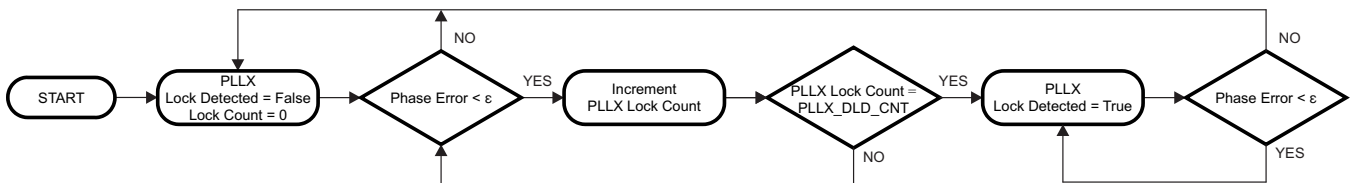

Figure 16. Digital Lock Detect Flowchart

This incremental lock detect count feature functions as a digital filter to ensure that lock detect isn't asserted for only a brief time when the phases of R and N are within the specified tolerance for only a brief time during initial phase lock.

See [Digital Lock Detect Frequency Accuracy](#) for more detailed information on programming the registers to achieve a specified frequency accuracy in ppm with lock detect.

The digital lock detect signal can be monitored on the Status_LD1 or Status_LD2 pin. The pin may be programmed to output the status of lock detect for PLL1, PLL2, or both PLL1 and PLL2.

9.3.6.1 Calculating Digital Lock Detect Frequency Accuracy

See [Digital Lock Detect Frequency Accuracy](#) for more detailed information on programming the registers to achieve a specified frequency accuracy in ppm with lock detect.

The digital lock detect feature can also be used with holdover to automatically exit holdover mode. See [Exiting Holdover](#) for more info.

9.3.7 Holdover

Holdover mode causes PLL2 to stay locked on frequency with minimal frequency drift when an input clock reference to PLL1 becomes invalid. While in holdover mode, the PLL1 charge pump is TRI-STATED and a fixed tuning voltage is set on CPout1 to operate PLL1 in open loop.

9.3.7.1 Enable Holdover

Program `HOLDOVER_EN = 1` to enable holdover mode.

Holdover mode can be configured to set the CPout1 voltage upon holdover entry to a fixed user defined voltage or a tracked voltage.

9.3.7.1.1 Fixed (Manual) CPout1 Holdover Mode

By programming `MAN_DAC_EN = 1`, then the `MAN_DAC` value will be set on the CPout1 pin during holdover.

The user can optionally enable CPout1 voltage tracking (`TRACK_EN = 1`), read back the tracked DAC value, then re-program `MAN_DAC` value to a user desired value based on information from previous DAC read backs. This allows the most user control over the holdover CPout1 voltage, but also requires more user intervention.

9.3.7.1.2 Tracked CPout1 Holdover Mode

By programming `MAN_DAC_EN = 0` and `TRACK_EN = 1`, the tracked voltage of CPout1 will be set on the CPout1 pin during holdover. When the DAC has acquired the current CPout1 voltage, the `DAC_Locked` signal is set which may be observed on `Status_LD1` or `Status_LD2` pins by programming `PLL1_LD_MUX` or `PLL2_LD_MUX` respectively.

Updates to the DAC value for the Tracked CPout1 sub-mode occurs at the rate of the PLL1 phase detector frequency divided by (`DAC_CLK_MULT * DAC_CLK_CNTR`).

The DAC update rate should be programmed for ≤ 100 kHz to ensure DAC holdover accuracy.

The ability to program slow DAC update rates, for example one DAC update per 4.08 seconds when using 1024 kHz PLL1 phase detector frequency with `DAC_CLK_MULT = 16,384` and `DAC_CLK_CNTR = 255`, allows the device to *look-back* and set CPout1 at at previous "good" CPout1 tuning voltage values before the event which caused holdover to occur.

The current voltage of DAC value can be read back using `RB_DAC_VALUE`, see [RB_DAC_VALUE](#).

9.3.7.2 During Holdover

PLL1 is run in open loop mode.

- PLL1 charge pump is set to TRI-STATE.
- PLL1 DLD will be un-asserted.
- The `HOLDOVER` status is asserted
- During holdover If PLL2 was locked prior to entry of holdover mode, PLL2 DLD will continue to be asserted.
- CPout1 voltage will be set to:
 - a voltage set in the `MAN_DAC` register (`MAN_DAC_EN = 1`).
 - a voltage determined to be the last valid CPout1 voltage (`MAN_DAC_EN = 0`).
- PLL1 will attempt to lock with the active clock input.

The `HOLDOVER` status signal can be monitored on the `Status_LD1` or `Status_LD2` pin by programming the `PLL1_DLD_MUX` or `PLL2_DLD_MUX` register to "Holdover Status."

9.3.7.3 Exiting Holdover

Holdover mode can be exited in one of two ways.

- Manually, by programming the device from the host.
- Automatically, By a clock operating within a specified ppm of the current PLL1 frequency on the active clock input.

9.3.7.4 Holdover Frequency Accuracy and DAC Performance

When in holdover mode, PLL1 will run in open loop and the DAC will set the CPout1 voltage. If Fixed CPout1 mode is used, then the output of the DAC will be a voltage dependant upon the MAN_DAC register. If Tracked CPout1 mode is used, then the output of the DAC will be the voltage at the CPout1 pin before holdover mode was entered. When using Tracked mode and MAN_DAC_EN = 1, during holdover the DAC value is loaded with the programmed value in MAN_DAC, not the tracked value.

When in Tracked CPout1 mode, the DAC has a worst case tracking error of ± 2 LSBs once PLL1 tuning voltage is acquired. The step size is approximately 3.2 mV, therefore the VCXO frequency error during holdover mode caused by the DAC tracking accuracy is $\pm 6.4 \text{ mV} \times K_v$, where K_v is the tuning sensitivity of the VCXO in use. Therefore, the accuracy of the system when in holdover mode in ppm is:

$$\text{Holdover accuracy (ppm)} = \frac{\pm 6.4 \text{ mV} \times K_v \times 1e6}{\text{VCXO Frequency}} \quad (1)$$

Example: consider a system with a 19.2 MHz clock input, a 153.6 MHz VCXO with a K_v of 17 kHz/V. The accuracy of the system in holdover in ppm is:

$$\pm 0.71 \text{ ppm} = \pm 6.4 \text{ mV} \times 17 \text{ kHz/V} \times 1e6 / 153.6 \text{ MHz} \quad (2)$$

It is important to account for this frequency error when determining the allowable frequency error window to cause holdover mode to exit.

9.3.7.5 Holdover Mode - Automatic Exit of Holdover

The LMK048xx device can be programmed to automatically exit holdover mode when the accuracy of the frequency on the active clock input achieves a specified accuracy. The programmable variables include PLL1_WND_SIZE and HOLDOVER_DLD_CNT.

See [Digital Lock Detect Frequency Accuracy](#) to calculate the register values to cause holdover to automatically exit upon reference signal recovery to within a user specified ppm error of the holdover frequency.

It is possible for the time to exit holdover to vary because the condition for automatic holdover exit is for the reference and feedback signals to have a time/phase error less than a programmable value. Because it is possible for two clock signals to be very close in frequency but not close in phase, it may take a long time for the phases of the clocks to align themselves within the allowable time/phase error before holdover exits.

9.4 Device Functional Modes

The following section describes the settings to enable various modes of operation for the LMK0482x family. See [Figure 12](#) and [Figure 13](#) for visual diagrams of each mode.

The LMK0482x Family is a flexible device that can be configured for many different use cases. The following simplified block diagrams help show the user the different use cases of the device.

9.4.1 DUAL PLL

[Figure 17](#) illustrates the typical use case of the LMK0482x family in dual loop mode. In dual loop mode the reference to PLL1 from CLKin0, CLKin1, or CLKin2. An external VCXO or tunable crystal will be used to provide feedback for the first PLL and a reference to the second PLL. This first PLL cleans the jitter with the VCXO or low cost tunable crystal by using a narrow loop bandwidth. The VCXO or tunable crystal output may be buffered through the OSCout port. The VCXO or tunable crystal is used as the reference to PLL2 and may be doubled using the frequency doubler. The internal VCO drives up to seven divide/delay blocks which drive up to 14 clock outputs.

Hitless switching and holdover functionality are optionally available when the input reference clock is lost. Holdover works by fixing the tuning voltage of PLL1 to the VCXO or tunable crystal.

It is also possible to use an external VCO in place of PLL2's internal VCO. In this case one less CLKin is available as a reference.

LMK04821 includes VCO1 divider on VCO1 output.

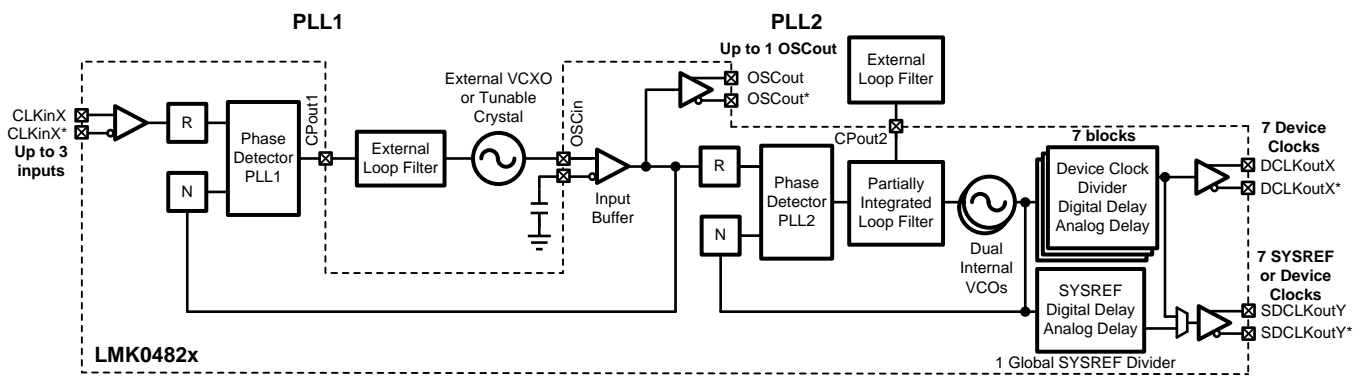

Figure 17. Simplified Functional Block Diagram for Dual Loop Mode

Table 5. Dual Loop Mode Register Configuration

FIELD	REGISTER ADDRESS	FUNCTION	VALUE	SELECTED VALUE
PLL1_NCLK_MUX	0x13F	Selects the input to the PLL1 N divider	0	OSCin
PLL2_NCLK_MUX	0x13F	Selects the input to the PLL2 N divider	0	PLL2_P
FB_MUX_EN	0x13F	Enables the Feedback Mux	0	Disabled
FB_MUX	0x13F	Selects the output of the Feedback Mux	X	Don't care because FB_MUX is disabled
OSCin_PD	0x140	Powers down the OSCin port	0	Powered up
CLKin0_OUT_MUX	0x147	Selects where the output of CLKin0 is directed.	2	PLL1
CLKin1_OUT_MUX	0x147	Selects where the output of CLKin1 is directed.	2	PLL1
VCO_MUX	0x138	Selects the VCO 0, 1 or an external VCO	0 or 1	VCO 0 or VCO 1

9.4.2 0-DELAY Dual PLL

Figure 18 illustrates the use case of cascaded 0-delay dual loop mode. This configuration differs from dual loop mode Figure 17 in that the feedback for PLL2 is driven by a clock output instead of the VCO output. Figure 19 illustrates the use case of nested 0-delay dual loop mode. This configuration is similar to the dual PLL in *DUAL PLL* except that the feedback to the first PLL is driven by a clock output. This causes the clock outputs to have deterministic phase relationship with the clock input. Since all the clock outputs can be synchronized together, all the clock outputs can share the same deterministic phase relationship with the clock input signal. The feedback to PLL1 can be connected internally as shown using CLKout6, CLKout8, SYSREF, or externally using FBCLKin (CLKin1).

It is also possible to use an external VCO in place of PLL2's internal VCO; but one less CLKin is available as a reference and external 0-delay feedback is not available.

LMK04821 includes VCO1 divider on VCO1 output.

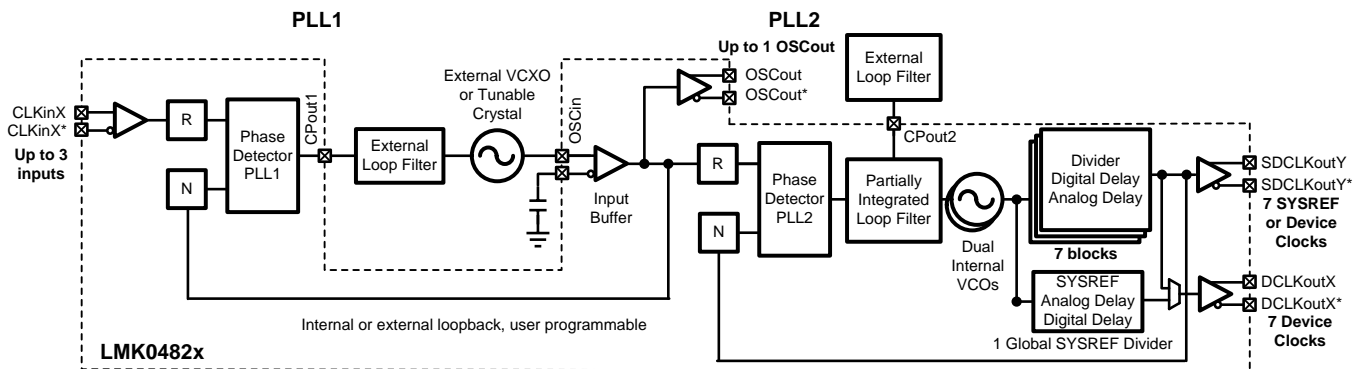

Figure 18. Simplified Functional Block Diagram for Cascaded 0-delay Dual Loop Mode

Table 6. Cascaded 0-delay Dual Loop Mode Register Configuration

FIELD	REGISTER ADDRESS	FUNCTION	VALUE	SELECTED VALUE
PLL1_NCLK_MUX	0x13F	Selects the input to the PLL1 N divider.	0	OSCin
PLL2_NCLK_MUX	0x13F	Selects the input to the PLL2 N divider	1	Feedback Mux
FB_MUX_EN	0x13F	Enables the Feedback Mux.	1	Feedback Mux Enabled
FB_MUX	0x13F	Selects the output of the Feedback Mux.	0, 1, or 2	Select between DCLKout6, DCLKout8, SYSREF
OSCin_PD	0x140	Powers down the OSCin port.	0	Powered up
CLKin0_OUT_MUX	0x147	Selects where the output of CLKin0 is directed.	0	PLL1
CLKin1_OUT_MUX	0x147	Selects where the output of CLKin1 is directed.	0 or 2	Fin or PLL1
VCO_MUX	0x138	Selects the VCO 0, 1 or an external VCO	0 or 1	VCO 0 or VCO 1

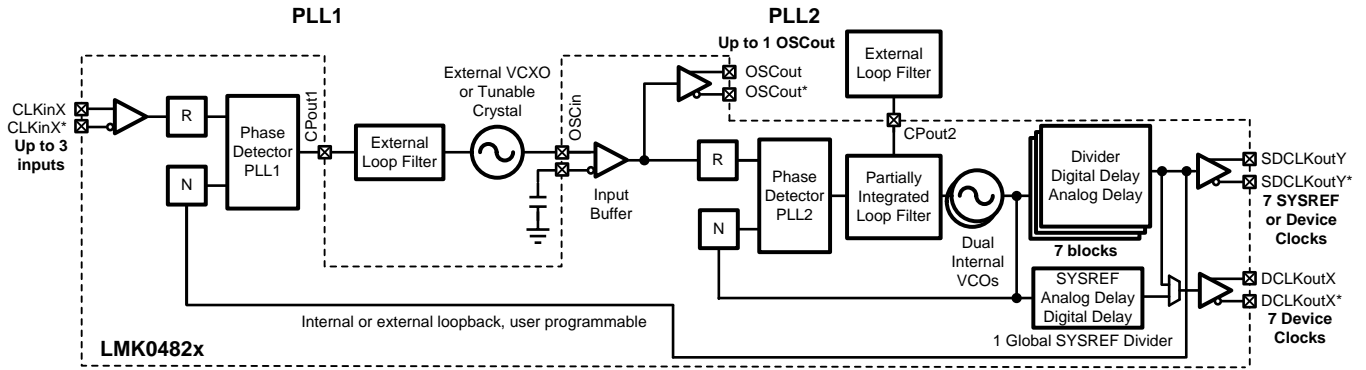

Figure 19. Simplified Functional Block Diagram for Nested 0-delay Dual Loop Mode

LMK04821 includes VCO1 divider on VCO1 output.

Table 7 illustrates nested 0-delay mode. This is the same as cascaded except the clock out feedback is to PLL1. The CLKin and CLKout have the same deterministic phase relationship but the VCXO's phase will not be deterministic to the CLKin or CLKouts.

Table 7. Nested 0-delay Dual Loop Mode Register Configuration

FIELD	REGISTER ADDRESS	FUNCTION	VALUE	SELECTED VALUE
PLL1_NCLK_MUX	0x13F	Selects the input to the PLL1 N divider.	1	Feedback Mux
PLL2_NCLK_MUX	0x13F	Selects the input to the PLL2 N divider	0	PLL2 P
FB_MUX_EN	0x13F	Enables the Feedback Mux.	1	Enabled
FB_MUX	0x13F	Selects the output of the Feedback Mux.	0, 1, or 2	Select between DCLKout6, DCLKout8, SYSREF
OSCin_PD	0x140	Powers down the OSCin port.	0	Powered up
CLKin0_OUT_MUX	0x147	Selects where the output of CLKin0 is directed.	2	PLL1
CLKin1_OUT_MUX	0x147	Selects where the output of CLKin1 is directed.	0 or 2	Fin or PLL1
VCO_MUX	0x138	Selects the VCO 0, 1 or an external VCO	0 or 1	VCO 0 or VCO 1

9.5 Programming

LMK0482x family devices are programmed using 24-bit registers. Each register consists of a 1-bit command field (R/W), a 2-bit multi-byte field (W1, W0), a 13-bit address field (A12 to A0) and a 8-bit data field (D7 to D0). The contents of each register is clocked in MSB first (R/W), and the LSB (D0) last. During programming, the CS* signal is held low. The serial data is clocked in on the rising edge of the SCK signal. After the LSB is clocked in, the CS* signal goes *high* to latch the contents into the shift register. It is recommended to program registers in numeric order -- for example, 0x000 to 0x1FFF -- to achieve proper device operation. Each register consists of one or more fields which control the device functionality. See electrical characteristics and [Figure 1](#) for timing details.

R/W bit = 0 is for SPI write. R/W bit = 1 is for SPI read.

W1 and W0 shall be written as 0.

9.5.1 Recommended Programming Sequence

Registers are programmed in numeric order with 0x000 being the first and 0x1FFF being the last register programmed. The recommended programming sequence from POR involves:

1. Program register 0x000 with RESET = 1.
2. Program registers in numeric order from 0x000 to 0x165. Ensure the following register is programmed as follows:
 - 0x145 = 127 (0x7F)
3. Program register 0x171 to 0xAA and 0x172 to 0x02.
4. If using LMK04821, program register 0x174.
5. Program registers 0x17C and 0x17D as required by [OPT_REG_1](#) and [OPT_REG_2](#).
6. Program registers 0x166 to 0x1FFF.

When using LMK04821: Program register 0x174, bits 4:0 (VCO1_DIV) with proper value before programming PLL2_N register in 0x166, 0x167, and 0x168 for proper total PLL2_N value.

Program register 0x171, 0x172, 0x17C (OPT_REG_1) and 0x17D (OPT_REG_2) before programming PLL2 in registers: 0x166, 0x167, and 0x168 to optimize PLL2_N and VCO1 phase noise performance over temperature.

9.5.1.1 SPI LOCK

When writing to SPI_LOCK, registers 0x1FFD, 0x1FFE, and 0x1FFF should all always be written sequentially.

9.5.1.2 SYSREF_CLR

When using SYSREF output, SYSREF local digital delay block should be cleared using SYSREF_CLR bit. See [SYSREF_CLR](#) for more info.

9.6 Register Maps

9.6.1 Register Map for Device Programming

Table 8 provides the register map for device programming. Any register can be read from the same data address it is written to.

Table 8. LMK0482x Register Map

ADDRESS	DATA							
	7	6	5	4	3	2	1	0
0x000	RESET	0	0	SPI_3WIRE_DIS	0	0	0	0
0x002	0	0	0	0	0	0	0	POWER DOWN
0x003	ID_DEVICE_TYPE							
0x004	ID_PROD[15:8]							
0x005	ID_PROD[7:0]							
0x006	ID_MASKREV							
0x00C	ID_VNDR[15:8]							
0x00D	ID_VNDR[7:0]							
0x100	0	CLKout0_1_ODL	CLKout0_1_IDL	DCLKout0_DIV				
0x101	DCLKout0_DDLY_CNTH				DCLKout0_DDLY_CNTL			
0x103	DCLKout0_ADLY					DCLKout0_ADLY_MUX	DCLKout0_MUX	
0x104	0	DCLKout0_HS	SDCLKout1_MUX	SDCLKout1_DDLY				SDCLKout1_HS
0x105	0	0	0	SDCLKout1_ADLY_EN	SDCLKout1_ADLY			
0x106	DCLKout0_DDLY_PD	DCLKout0_HSg_PD	DCLKout0_ADLYg_PD	DCLKout0_ADLY_PD	CLKout0_1_PD	SDCLKout1_DIS_MODE		SDCLKout1_PD
0x107	SDCLKout1_POL	CLKout1_FMT			DCLKout0_POL	CLKout0_FMT		
0x108	0	CLKout2_3_ODL	CLKout2_3_IDL	DCLKout2_DIV				
0x109	DCLKout2_DDLY_CNTH				DCLKout2_DDLY_CNTL			
0x10B	DCLKout2_ADLY					DCLKout2_ADLY_MUX	DCLKout2_MUX	
0x10C	0	DCLKout2_HS	SDCLKout3_MUX	SDCLKout3_DDLY				SDCLKout3_HS
0x10D	0	0	0	SDCLKout3_ADLY_EN	SDCLKout3_ADLY			
0x10E	DCLKout2_DDLY_PD	DCLKout2_HSg_PD	DCLKout2_ADLYg_PD	DCLKout2_ADLY_PD	CLKout2_3_PD	SDCLKout3_DIS_MODE		SDCLKout3_PD
0x10F	SDCLKout3_POL	CLKout3_FMT			DCLKout2_POL	CLKout2_FMT		
0x110	0	CLKout4_5_ODL	CLKout4_5_IDL	DCLKout4_DIV				
0x111	DCLKout4_DDLY_CNTH				DCLKout4_DDLY_CNTL			
0x113	DCLKout4_ADLY					DCLKout4_ADLY_MUX	DCLKout4_MUX	
0x114	0	DCLKout4_HS	SDCLKout5_MUX	SDCLKout5_DDLY				SDCLKout5_HS
0x115	0	0	0	SDCLKout5_ADLY_EN	SDCLKout5_ADLY			
0x116	DCLKout4_DDLY_PD	DCLKout4_HSg_PD	DCLKout4_ADLYg_PD	DCLKout4_ADLY_PD	CLKout4_5_PD	SDCLKout5_DIS_MODE		SDCLKout5_PD
0x117	SDCLKout5_POL	CLKout5_FMT			DCLKout4_POL	CLKout4_FMT		
0x118	0	CLKout6_7_ODL	CLKout6_8_IDL	DCLKout6_DIV				

Register Maps (continued)
Table 8. LMK0482x Register Map (continued)

ADDRESS	DATA							
	7	6	5	4	3	2	1	0
0x119	DCLKout6_DDLY_CNTH				DCLKout6_DDLY_CNTL			
0x11B	DCLKout6_ADLY					DCLKout6_ADLY_MUX	DCLKout6_MUX	
0x11C	0	DCLKout6_HS	SDCLKout7_MUX	SDCLKout7_DDLY			SDCLKout7_HS	
0x11D	0	0	0	SDCLKout7_ADLY_EN	SDCLKout7_ADLY			
0x11E	DCLKout6_DDLY_PD	DCLKout6_HSg_PD	DCLKout6_ADLYg_PD	DCLKout6_ADLY_PD	CLKout6_7_PD	SDCLKout7_DIS_MODE	SDCLKout7_PD	
0x11F	SDCLKout7_POL	CLKout7_FMT			DCLKout6_POL	CLKout6_FMT		
0x120	0	CLKout8_9_ODL	CLKout8_9_IDL	DCLKout8_DIV				
0x121	DCLKout8_DDLY_CNTH				DCLKout8_DDLY_CNTL			
0x123	DCLKout8_ADLY					DCLKout8_ADLY_MUX	DCLKout8_MUX	
0x124	0	DCLKout8_HS	SDCLKout9_MUX	SDCLKout9_DDLY			SDCLKout9_HS	
0x125	0	0	0	SDCLKout9_ADLY_EN	SDCLKout9_ADLY			
0x126	DCLKout8_DDLY_PD	DCLKout8_HSg_PD	DCLKout8_ADLYg_PD	DCLKout8_ADLY_PD	CLKout8_9_PD	SDCLKout9_DIS_MODE	SDCLKout9_PD	
0x127	SDCLKout9_POL	CLKout9_FMT			DCLKout8_POL	CLKout8_FMT		
0x128	0	CLKout10_11_ODL	CLKout10_11_IDL	DCLKout10_DIV				
0x129	DCLKout10_DDLY_CNTH				DCLKout10_DDLY_CNTL			
0x12B	DCLKout10_ADLY					DCLKout10_ADLY_MUX	DCLKout10_MUX	
0x12C	0	DCLKout10_HS	SDCLKout11_MUX	SDCLKout11_DDLY			SDCLKout11_HS	
0x12D	0	0	0	SDCLKout11_ADLY_EN	SDCLKout11_ADLY			
0x12E	DCLKout10_DDLY_PD	DCLKout10_HSg_PD	DCLKout10_ADLYg_PD	DCLKout10_ADLY_PD	CLKout10_11_PD	SDCLKout11_DIS_MODE	SDCLKout11_PD	
0x12F	SDCLKout11_POL	CLKout11_FMT			DCLKout10_POL	CLKout10_FMT		
0x130	0	CLKout12_13_ODL	CLKout12_13_IDL	DCLKout12_DIV				
0x131	DCLKout12_DDLY_CNTH				DCLKout12_DDLY_CNTL			
0x133	DCLKout12_ADLY					DCLKout12_ADLY_MUX	DCLKout12_MUX	
0x134	0	DCLKout12_HS	SDCLKout13_MUX	SDCLKout13_DDLY			SDCLKout13_HS	
0x135	0	0	0	SDCLKout13_ADLY_EN	SDCLKout13_ADLY			
0x136	DCLKout12_DDLY_PD	DCLKout12_HSg_PD	DCLKout12_ADLYg_PD	DCLKout12_ADLY_PD	CLKout12_13_PD	SDCLKout13_DIS_MODE	SDCLKout13_PD	
0x137	SDCLKout13_POL	CLKout13_FMT			DCLKout12_POL	CLKout12_FMT		
0x138	0	VCO_MUX		OSCOut_MUX	OSCOut_FMT			
0x139	0	0	0	0	0	SYSREF_CLKin0_MUX	SYSREF_MUX	
0x13A	0	0	0	SYSREF_DIV[12:8]				
0x13B	SYSREF_DIV[7:0]							
0x13C	0	0	0	SYSREF_DDLY[12:8]				

Register Maps (continued)
Table 8. LMK0482x Register Map (continued)

ADDRESS	DATA							
[11:0]	7	6	5	4	3	2	1	0
0x13D	SYSREF_DDLY[7:0]							
0x13E	0	0	0	0	0	0	SYSREF_PULSE_CNT	
0x13F	0	0	0	PLL2_NCLK_MUX	PLL1_NCLK_MUX	FB_MUX		FB_MUX_EN
0x140	PLL1_PD	VCO_LDO_PD	VCO_PD	OSCin_PD	SYSREF_GBL_PD	SYSREF_PD	SYSREF_DDLY_PD	SYSREF_PLSR_PD
0x141	DDLYd_SYSREF_EN	DDLYd12_EN	DDLYd10_EN	DDLYd7_EN	DDLYd6_EN	DDLYd4_EN	DDLYd2_EN	DDLYd0_EN
0x142	0	0	0	DDLYd_STEP_CNT				
0x143	SYSREF_DDLY_CLR	SYNC_1SHOT_EN	SYNC_POL	SYNC_EN	SYNC_PLL2_DLD	SYNC_PLL1_DLD	SYNC_MODE	
0x144	SYNC_DISSYSREF	SYNC_DIS12	SYNC_DIS10	SYNC_DIS8	SYNC_DIS6	SYNC_DIS4	SYNC_DIS2	SYNC_DIS0
0x145	0	1	1	1	1	1	1	1
0x146	0	0	CLKin2_EN	CLKin1_EN	CLKin0_EN	CLKin2_TYPE	CLKin1_TYPE	CLKin0_TYPE
0x147	CLKin_SEL_POL	CLKin_SEL_MODE			CLKin1_OUT_MUX		CLKin0_OUT_MUX	
0x148	0	0	CLKin_SEL0_MUX			CLKin_SEL0_TYPE		
0x149	0	SDIO_RDBK_TYPE	CLKin_SEL1_MUX			CLKin_SEL1_TYPE		
0x14A	0	0	RESET_MUX			RESET_TYPE		
0x14B	LOS_TIMEOUT		LOS_EN	TRACK_EN	HOLDOVER_FORCE	MAN_DAC_EN	MAN_DAC[9:8]	
0x14C	MAN_DAC[7:0]							
0x14D	0	0	DAC_TRIP_LOW					
0x14E	DAC_CLK_MULT		DAC_TRIP_HIGH					
0x14F	DAC_CLK_CNTR							
0x150	0	CLKin_OVERRIDE	0	HOLDOVER_PLL1_DET	HOLDOVER_LOS_DET	HOLDOVER_VTUNE_DET	HOLDOVER_HITLESS_SWITCH	HOLDOVER_EN
0x151	0	0	HOLDOVER_DLD_CNT[13:8]					
0x152	HOLDOVER_DLD_CNT[7:0]							
0x153	0	0	CLKin0_R[13:8]					
0x154	CLKin0_R[7:0]							
0x155	0	0	CLKin1_R[13:8]					
0x156	CLKin1_R[7:0]							
0x157	0	0	CLKin2_R[13:8]					
0x158	CLKin2_R[7:0]							
0x159	0	0	PLL1_N[13:8]					
0x15A	PLL1_N[7:0]							
0x15B	PLL1_WND_SIZE		PLL1_CP_TRI	PLL1_CP_POL	PLL1_CP_GAIN			
0x15C	0	0	PLL1_DLD_CNT[13:8]					
0x15D	PLL1_DLD_CNT[7:0]							
0x15E	0	0	PLL1_R_DLY			PLL1_N_DLY		
0x15F	PLL1_LD_MUX					PLL1_LD_TYPE		
0x160	0	0	0	0	PLL2_R[11:8]			
0x161	PLL2_R[7:0]							
0x162	PLL2_P			OSCin_FREQ			PLL2_XTAL_EN	PLL2_REF_2X_EN
0x163	0	0	0	0	0	0	PLL2_N_CAL[17:16]	
0x164	PLL2_N_CAL[15:8]							
0x165	PLL2_N_CAL[7:0]							

Register Maps (continued)
Table 8. LMK0482x Register Map (continued)

ADDRESS	DATA							
	7	6	5	4	3	2	1	0
0x166	0	0	0	0	0	PLL2_FCAL_DIS	PLL2_N[17:16]	
0x167	PLL2_N[15:8]							
0x168	PLL2_N[7:0]							
0x169	0	PLL2_WND_SIZE		PLL2_CP_GAIN		PLL2_CP_POL	PLL2_CP_TRI	1
0x16A	0	SYSREF_REQ_EN	PLL2_DLD_CNT[15:8]					
0x16B	PLL2_DLD_CNT[7:0]							
0x16C	0	0	PLL2_LF_R4			PLL2_LF_R3		
0x16D	PLL2_LF_C4				PLL2_LF_C3			
0x16E	PLL2_LD_MUX				PLL2_LD_TYPE			
0x171	1	0	1	0	1	0	1	0
0x172	0	0	0	0	0	0	1	0
0x173	0	PLL2_PRE_PD	PLL2_PD	0	0	0	0	0
0x174	0	0	0	VCO1_DIV				
0x17C	OPT_REG_1							
0x17D	OPT_REG_2							
0x182	0	0	0	0	0	RB_PLL1_LD_LOST	RB_PLL1_LD	CLR_PLL1_LD_LOST
0x183	0	0	0	0	0	RB_PLL2_LD_LOST	RB_PLL2_LD	CLR_PLL2_LD_LOST
0x184	RB_DAC_VALUE[9:8]		RB_CLKin2_SEL	RB_CLKin1_SEL	RB_CLKin0_SEL	X	RB_CLKin1_LOS	RB_CLKin0_LOS
0x185	RB_DAC_VALUE[7:0]							
0x188	0	0	0	RB_HOLD OVER	X	X	X	X
0x1FFD	SPI_LOCK[23:16]							
0x1FFE	SPI_LOCK[15:8]							
0x1FFF	SPI_LOCK[7:0]							

9.7 Device Register Descriptions

The following section details the fields of each register, the Power On Reset Defaults, and specific descriptions of each bit.

In some cases similar fields are located in multiple registers. In this case specific outputs may be designated as X or Y. In these cases the X will represent even numbers from 0 to 12 and the Y will represent odd numbers from 1 to 13. In the case where X and Y are both used in a bit name, then $Y = X + 1$.

9.7.1 System Functions

9.7.1.1 RESET, SPI_3WIRE_DIS

This register contains the RESET function.

Table 9. Register 0x000

BIT	NAME	POR DEFAULT	DESCRIPTION
7	RESET	0	0: Normal Operation 1: Reset (automatically cleared)
6:5	NA	0	Reserved
4	SPI_3WIRE_DIS	0	Disable 3 wire SPI mode. 4 Wire SPI mode is enabled by selecting SPI Read back in one of the output MUX settings. For example CLKIn0_SEL_MUX. 0: 3 Wire Mode enabled 1: 3 Wire Mode disabled
3:0	NA	NA	Reserved

9.7.1.2 POWERDOWN

This register contains the POWERDOWN function.

Table 10. Register 0x002

BIT	NAME	POR DEFAULT	DESCRIPTION
7:1	NA	0	Reserved
0	POWERDOWN	0	0: Normal Operation 1: Powerdown

9.7.1.3 ID_DEVICE_TYPE

This register contains the product device type. This is read only register.

Table 11. Register 0x003

BIT	NAME	POR DEFAULT	DESCRIPTION
7:0	ID_DEVICE_TYPE	6	PLL product device type.

9.7.1.4 ID_PROD[15:8], ID_PROD

These registers contain the product identifier. This is a read only register.

Table 12. ID_PROD Register Configuration, ID_PROD[15:0]

MSB	LSB
0x004[7:0]	0x005[7:0]

BIT	REGISTERS	FIELD NAME	POR DEFAULT	DESCRIPTION
7:0	0x004	ID_PROD[15:8]	208	MSB of the product identifier.
7:0	0x005	ID_PROD	91	LSB of the product identifier.

9.7.1.5 ID_MASKREV

This register contains the IC version identifier. This is a read only register.

Table 13. Register 0x006

BIT	NAME	POR DEFAULT	DESCRIPTION
7:0	ID_MASKREV	36	IC version identifier for LMK04821
		37	IC version identifier for LMK04826
		32	IC version identifier for LMK04828

9.7.1.6 ID_VNDR[15:8], ID_VNDR

These registers contain the vendor identifier. This is a read only register.

Table 14. ID_VNDR Register Configuration, ID_VNDR[15:0]

MSB	LSB
0x00C[7:0]	0x00D[7:0]

Table 15. Registers 0x00C, 0x00D

BIT	REGISTERS	NAME	POR DEFAULT	DESCRIPTION
7:0	0x00C	ID_VNDR[15:8]	81	MSB of the vendor identifier.
7:0	0x00D	ID_VNDR	4	LSB of the vendor identifier.

9.7.2 (0x100 - 0x138) Device Clock and SYSREF Clock Output Controls

9.7.2.1 CLKoutX_Y_ODL, CLKoutX_Y_IDL, DCLKoutX_DIV

These registers control the input and output drive level as well as the device clock out divider values.

Table 16. Registers 0x100, 0x108, 0x110, 0x118, 0x120, 0x128, and 0x130

BIT	NAME	POR DEFAULT	DESCRIPTION	
7	NA	0	Reserved	
6	CLKoutX_Y_ODL	0	Output drive level.	
5	CLKoutX_Y_IDL	0	Input drive level.	
4:0	DCLKoutX_DIV	X = 0 → 2 X = 2 → 4 X = 4 → 8 X = 6 → 8 X = 8 → 8 X = 10 → 8 X = 12 → 2	DCLKoutX_DIV sets the divide value for the clock output, the divide may be even or odd. Both even or odd divides output a 50% duty cycle clock if duty cycle correction (DCC) is selected. Divider is unused if DCLKoutX_MUX = 2 (bypass), equivalent divide of 1.	
			Field Value	Divider Value
			0 (0x00)	32
			1 (0x01)	1 ⁽¹⁾
			2 (0x02)	2
		
			30 (0x1E)	30
			31 (0x1F)	31

(1) Not valid if DCLKoutX_MUX = 0, Divider only. Not valid if DCLKoutX_MUX = 3 (Analog Delay + Divider) and DCLKoutX_ADLY_MUX = 0 (without duty cycle correction/halfstep).

9.7.2.2 DCLKoutX_DDLY_CNTH, DCLKoutX_DDLY_CNTL

This register controls the digital delay high and low count values for the device clock outputs.

Table 17. Registers 0x101, 0x109, 0x111, 0x119, 0x121, 0x129, 0x131

BIT	NAME	POR DEFAULT	DESCRIPTION	
7:4	DCLKoutX_DDLY_CNTH	5	Number of clock cycles the output will be high when digital delay is engaged.	
			Field Value	Delay Values
			0 (0x00)	16
			1 (0x01)	Reserved
			2 (0x02)	2
			15 (0x0F)	15
3:0	DCLKoutX_DDLY_CNTL	5	Number of clock cycles the output will be low when dynamic digital delay is engaged.	
			Field Value	Delay Values
			0 (0x00)	16
			1 (0x01)	Reserved
			2 (0x02)	2
			15 (0x0F)	15

9.7.2.3 DCLKoutX_ADLY, DCLKoutX_ADLY_MUX, DCLKout_MUX

These registers control the analog delay properties for the device clocks.

Table 18. Registers 0x103, 0x10B, 0x113, 0x11B, 0x123, 0x12B, 0x133

BIT	NAME	POR DEFAULT	DESCRIPTION	
7:3	DCLKoutX_ADLY	0	Device clock analog delay value. Setting this value results in a 500 ps timing delay in additional to the delay of each 25 ps step. Effective range is 500 ps to 1075 ps.	
			Field Value	Delay Value
			0 (0x00)	0 ps
			1 (0x01)	25 ps
			2 (0x02)	50 ps
			23 (0x17)	575 ps
2	DCLKoutX_ADLY_MUX	0	This register selects the input to the analog delay for the device clock. Used when DCLKoutX_MUX = 3. 0: Divided without duty cycle correction or half step. ⁽¹⁾ 1: Divided with duty cycle correction and half step.	
1:0	DCLKoutX_MUX	0	This selects the input to the device clock buffer.	
			Field Value	Mux Output
			0 (0x0)	Divider only ⁽¹⁾
			1 (0x1)	Divider with Duty Cycle Correction and Half Step
			3 (0x3)	Analog Delay + Divider

(1) DCLKoutX_DIV = 1 is not valid.

9.7.2.4 DCLKoutX_HS, SDCLKoutY_MUX, SDCLKoutY_DDLY, SDCLKoutY_HS

These registers set the half step for the device clock, the SYSREF output MUX, the SYSREF clock digital delay, and half step.

Table 19. Registers 0x104, 0x10C, 0x114, 0x11C, 0x124, 0x12C, 0x134

BIT	NAME	POR DEFAULT	DESCRIPTION	
7	NA	0	Reserved	
6	DCLKoutX_HS	0	Sets the device clock half step value. Half step must be zero (0) for a divide of 1. 0: 0 cycles 1: -0.5 cycles	
5	SDCLKoutY_MUX	0	Sets the input the the SDCLKoutX outputs. 0: Device clock output 1: SYSREF output	
4:1	SDCLKoutY_DDLY	0	Sets the number of VCO cycles to delay the SDCLKout by.	
			Field Value	Delay Cycles
			0 (0x00)	Bypass
			1 (0x01)	2
			2 (0x02)	3
			11 to 15 (0x0B to 0x0F)	Reserved
0	SDCLKoutY_HS	0	Sets the SYSREF clock half step value. 0: 0 cycles 1: -0.5 cycles	

9.7.2.5 SDCLKoutY_ADLY_EN, SDCLKoutY_ADLY

These registers set the analog delay parameters for the SYSREF outputs.

Table 20. Registers 0x105, 0x10D, 0x115, 0x11D, 0x125, 0x12D, 0x135

BIT	NAME	POR DEFAULT	DESCRIPTION	
7:5	NA	0	Reserved	
4	SDCLKoutY _ADLY_EN	0	Enables analog delay for the SYSREF output. 0: Disabled 1: Enabled	
3:0	SDCLKoutY _ADLY	0	Sets the analog delay value for the SYSREF output. Selecting analog delay adds an additional 700 ps in propagation delay. Effective range is 700 ps to 2950 ps.	
			Field Value	Delay Value
			0 (0x0)	0 ps
			1 (0x1)	600 ps
			2 (0x2)	750 ps (+150 ps from 0x1)
			3 (0x3)	900 ps (+150 ps from 0x2)
		
			14 (0xE)	2100 ps (+150 ps from 0xD)
15 (0xF)	2250 ps (+150 ps from 0xE)			

9.7.2.6 DCLKoutX_DDLY_PD, DCLKoutX_HSg_PD, DCLKout_ADLYg_PD, DCLKout_ADLY_PD, DCLKoutX_Y_PD, SDCLKoutY_DIS_MODE, SDCLKoutY_PD

This register controls the power down functions for the digital delay, glitchless half step, glitchless analog delay, analog delay, outputs, and SYSREF disable modes.

Table 21. Registers 0x106, 0x10E, 0x116, 0x11E, 0x126, 0x12E, 0x136

BIT	NAME	POR DEFAULT	DESCRIPTION	
7	DCLKoutX_DDLY_PD	0	Powerdown the device clock digital delay circuitry. 0: Enabled 1: Powerdown	
6	DCLKoutX_HSg_PD	1	Powerdown the device clock glitchless half step feature. 0: Enabled 1: Powerdown	
5	DCLKoutX_ADLYg_PD	1	Powerdown the device clock glitchless analog delay feature. 0: Enabled, analog delay step size of one code is glitchless between values 1 to 23. 1: Powerdown	
4	DCLKoutX_ADLY_PD	1	Powerdown the device clock analog delay feature. 0: Enabled 1: Powerdown	
3	CLKoutX_Y_PD	X_Y = 0_1 → 1 X_Y = 2_3 → 1 X_Y = 4_5 → 0 X_Y = 6_7 → 0 X_Y = 8_9 → 0 X_Y = 10_11 → 0 X_Y = 12_13 → 1	Powerdown the clock group defined by X and Y. 0: Enabled 1: Powerdown	
2:1	SDCLKoutY_DIS_MODE	0	Configures the output state of the SYSREF	
			Field Value	Disable Mode
			0 (0x00)	Active in normal operation
			1 (0x01)	If SYSREF_GBL_PD = 1, the output is a logic low, otherwise it is active.
			2 (0x02)	If SYSREF_GBL_PD = 1, the output is a nominal Vcm voltage ⁽¹⁾ , otherwise it is active.
3 (0x03)	Output is a nominal Vcm voltage ⁽¹⁾			
0	SDCLKoutY_PD	1	Powerdown SDCLKoutY and set to the state defined by SDCLKoutY_DIS_MODE	

(1) If LVPECL mode is used with emitter resistors to ground, the output Vcm will be -0 V, each pin will be -0 V.

9.7.2.7 SDCLKoutY_POL, SDCLKoutY_FMT, DCLKoutX_POL, DCLKoutX_FMT

These registers configure the output polarity, and format.

Table 22. Registers 0x107, 0x10F, 0x117, 0x11F, 0x127, 0x12F, 0x137

BIT	NAME	POR DEFAULT	DESCRIPTION	
7	SDCLKoutY_POL	0	Sets the polarity of clock on SDCLKoutY when device clock output is selected with SDCLKoutY_MUX. 0: Normal 1: Inverted	
6:4	SDCLKoutY_FMT	0	Sets the output format of the SYSREF clocks	
			Field Value	Output Format
			0 (0x00)	Powerdown
			1 (0x01)	LVDS
			2 (0x02)	HSDS 6 mA
			3 (0x03)	HSDS 8 mA
			4 (0x04)	HSDS 10 mA
			5 (0x05)	LVPECL 1600 mV
			6 (0x06)	LVPECL 2000 mV
7 (0x07)	LCPECL			
3	DCLKoutX_POL	0	Sets the polarity of the device clocks from the DCLKoutX outputs 0: Normal 1: Inverted	
2:0	DCLKoutX_FMT	LMK04821: 0 LMK04826B/ LMK04828B: X = 0 → 0 X = 2 → 0 X = 4 → 1 X = 6 → 1 X = 8 → 1 X = 10 → 1 X = 12 → 0	Sets the output format of the device clocks.	
			Field Value	Output Format
			0 (0x00)	Powerdown
			1 (0x01)	LVDS
			2 (0x02)	HSDS 6 mA
			3 (0x03)	HSDS 8 mA
			4 (0x04)	HSDS 10 mA
			5 (0x05)	LVPECL 1600 mV
			6 (0x06)	LVPECL 2000 mV
7 (0x07)	LCPECL			

9.7.3 SYSREF, SYNC, and Device Config

9.7.3.1 VCO_MUX, OSCout_MUX, OSCout_FMT

This register selects the clock distribution source, and OSCout parameters.

Table 23. Register 0x138

BIT	NAME	POR DEFAULT	DESCRIPTION	
7	NA	0	Reserved	
6:5	VCO_MUX	0	Selects clock distribution path source from VCO0, VCO1, or CLKin (external VCO)	
			Field Value	VCO Selected
			0 (0x00)	VCO 0
			1 (0x01)	VCO 1
			2 (0x02)	CLKin1 (external VCO)
			3 (0x03)	Reserved
4	OSCout_MUX	0	Select the source for OSCout: 0: Buffered OSCin 1: Feedback Mux	
3:0	OSCout_FMT	4	Selects the output format of OSCout. When powered down, these pins may be used as CLKin2.	
			Field Value	OSCout Format
			0 (0x00)	Powerdown (CLKin2)
			1 (0x01)	LVDS
			2 (0x02)	Reserved
			3 (0x03)	Reserved
			4 (0x04)	LVPECL 1600 mVpp
			5 (0x05)	LVPECL 2000 mVpp
			6 (0x06)	LVC MOS (Norm / Inv)
			7 (0x07)	LVC MOS (Inv / Norm)
			8 (0x08)	LVC MOS (Norm / Norm)
			9 (0x09)	LVC MOS (Inv / Inv)
			10 (0x0A)	LVC MOS (Off / Norm)
			11 (0x0B)	LVC MOS (Off / Inv)
			12 (0x0C)	LVC MOS (Norm / Off)
13 (0x0D)	LVC MOS (Inv / Off)			
14 (0x0E)	LVC MOS (Off / Off)			

9.7.3.2 SYSREF_CLKin0_MUX, SYSREF_MUX

This register sets the source for the SYSREF outputs. Refer to [Figure 13](#) and [SYNC/SYSREF](#).

Table 24. Register 0x139

BIT	NAME	POR DEFAULT	DESCRIPTION	
7:3	NA	0	Reserved	
2	SYSREF_ CLKin0_MUX	0	Selects the SYSREF output from SYSREF_MUX or CLKin0 direct	
			Field Value	SYSREF Source
			0	SYSREF Mux
			1	CLKin0 Direct (from CLKin0_OUT_MUX)
1:0	SYSREF_MUX	0	Selects the SYSREF source.	
			Field Value	SYSREF Source
			0 (0x00)	Normal SYNC
			1 (0x01)	Re-clocked
			2 (0x02)	SYSREF Pulser
			3 (0x03)	SYSREF Continuous

9.7.3.3 SYSREF_DIV[12:8], SYSREF_DIV[7:0]

These registers set the value of the SYSREF output divider.

Table 25. Registers 0x13A, 0x13B

MSB				LSB	
0x13A[4:0]				0x13B[7:0]	

BIT	REGISTERS	NAME	POR DEFAULT	DESCRIPTION	
7:5	0x13A	NA	0	Reserved	
4:0	0x13A	SYSREF_DIV[12:8]	12	Divide value for the SYSREF outputs.	
				Field Value	Divide Value
				0x00 to 0x07	Reserved
				8 (0x08)	8
7:0	0x13B	SYSREF_DIV[7:0]	0	9 (0x09)	9
			
				8190 (0x1FFE)	8190
				8191 (0x1FFF)	8191

9.7.3.4 SYSREF_DDLY[12:8], SYSREF_DDLY[7:0]

These registers set the delay of the SYSREF digital delay value.

Table 26. SYSREF Digital Delay Register Configuration, SYSREF_DDLY[12:0]

MSB				LSB	
0x13C[4:0]				0x13D[7:0]	

BIT	REGISTERS	NAME	POR DEFAULT	DESCRIPTION	
7:5	0x13C	NA	0	Reserved	
4:0	0x13C	SYSREF_DDLY[12:8]	0	Sets the value of the SYSREF digital delay.	
				Field Value	Delay Value
				0x00 to 0x07	Reserved
				8 (0x08)	8
7:0	0x13D	SYSREF_DDLY[7:0]	8	9 (0x09)	9
			
				8190 (0x1FFE)	8190
				8191 (0x1FFF)	8191

9.7.3.5 SYSREF_PULSE_CNT

This register sets the number of SYSREF pulses if SYSREF is not in continuous mode. See [SYSREF_CLKin0_MUX](#), [SYSREF_MUX](#) for further description of SYSREF's outputs.

Programming the register causes the specified number of pulses to be output if "SYSREF Pulses" is selected by SYSREF_MUX and SYSREF functionality is powered up.

Table 27. Register 0x13E

BIT	NAME	POR DEFAULT	DESCRIPTION	
7:2	NA	0	Reserved	
1:0	SYSREF_PULSE_CNT	3	Sets the number of SYSREF pulses generated when not in continuous mode. See SYSREF_CLKin0_MUX , SYSREF_MUX for more information on SYSREF modes.	
			Field Value	Number of Pulses
			0 (0x00)	1 pulse
			1 (0x01)	2 pulses
			2 (0x02)	4 pulses
			3 (0x03)	8 pulses

9.7.3.6 PLL2_NCLK_MUX, PLL1_NCLK_MUX, FB_MUX, FB_MUX_EN

This register controls the feedback feature.

Table 28. Register 0x13F

BIT	NAME	POR DEFAULT	DESCRIPTION	
7:5	NA	0	Reserved	
4	PLL2_NCLK_MUX	0	Selects the input to the PLL2 N Divider 0: PLL Prescaler 1: Feedback Mux	
3	PLL1_NCLK_MUX	0	Selects the input to the PLL1 N Delay. 0: OSCin 1: Feedback Mux	
2:1	FB_MUX	0	When in 0-delay mode, the feedback mux selects the clock output to be fed back into the PLL1 N Divider.	
			Field Value	Source
			0 (0x00)	DCLKout6
			1 (0x01)	DCLKout8
			2 (0x02)	SYSREF Divider
			3 (0x03)	External
0	FB_MUX_EN	0	When using 0-delay, FB_MUX_EN must be set to 1 power up the feedback mux. 0: Feedback mux powered down 1: Feedback mux enabled	

9.7.3.7 PLL1_PD, VCO_LDO_PD, VCO_PD, OSCin_PD, SYSREF_GBL_PD, SYSREF_PD, SYSREF_DDLY_PD, SYSREF_PLSR_PD

This register contains powerdown controls for OSCin and SYSREF functions.

Table 29. Register 0x140

BIT	NAME	POR DEFAULT	DESCRIPTION
7	PLL1_PD	0	Powerdown PLL1 0: Normal operation 1: Powerdown
6	VCO_LDO_PD	0	Powerdown VCO_LDO 0: Normal operation 1: Powerdown
5	VCO_PD	0	Powerdown VCO 0: Normal operation 1: Powerdown
4	OSCin_PD	0	Powerdown the OSCin port. 0: Normal operation 1: Powerdown
3	SYSREF_GBL_PD	0	Powerdown individual SYSREF outputs depending on the setting of SDCLKoutY_DIS_MODE for each SYSREF output. SYSREF_GBL_PD allows many SYSREF outputs to be controlled through a single bit. 0: Normal operation 1: Activate Powerdown Mode
2	SYSREF_PD	1	Powerdown the SYSREF circuitry and divider. If powered down, SYSREF output mode cannot be used. SYNC cannot be provided either. 0: SYSREF can be used as programmed by individual SYSREF output registers. 1: Powerdown
1	SYSREF_DDLY_PD	1	Powerdown the SYSREF digital delay circuitry. 0: Normal operation, SYSREF digital delay may be used. Must be powered up during SYNC for deterministic phase relationship with other clocks. 1: Powerdown
0	SYSREF_PLSR_PD	1	Powerdown the SYSREF pulse generator. 0: Normal operation 1: Powerdown

9.7.3.8 DDLYdSYSREF_EN, DDLYdX_EN

This register enables dynamic digital delay for enabled device clocks and SYSREF when DDLYd_STEP_CNT is programmed.

Table 30. Register 0x141

BIT	NAME	POR DEFAULT	DESCRIPTION
7	DDLYd_SYSREF_EN	0	Enables dynamic digital delay on SYSREF outputs
6	DDLYd12_EN	0	Enables dynamic digital delay on DCLKout12
5	DDLYd10_EN	0	Enables dynamic digital delay on DCLKout10
4	DDLYd8_EN	0	Enables dynamic digital delay on DCLKout8
3	DDLYd6_EN	0	Enables dynamic digital delay on DCLKout6
2	DDLYd4_EN	0	Enables dynamic digital delay on DCLKout4
1	DDLYd2_EN	0	Enables dynamic digital delay on DCLKout2
0	DDLYd0_EN	0	Enables dynamic digital delay on DCLKout0

0: Disabled
1: Enabled

9.7.3.9 DDLYd_STEP_CNT

This register sets the number of dynamic digital delay adjustments occur. Upon programming, the dynamic digital delay adjustment begins for each clock output with dynamic digital delay enabled. Dynamic digital delay can only be started by SPI.

Other registers must be set: SYNC_MODE = 3

Table 31. Register 0x142

BIT	NAME	POR DEFAULT	DESCRIPTION	
7:4	NA	0	Reserved	
3:0	DDLYd_STEP_CNT	0	Sets the number of dynamic digital delay adjustments that will occur.	
			Field Value	SYNC Generation
			0 (0x00)	No Adjust
			1 (0x01)	1 step
			2 (0x02)	2 steps
			3 (0x03)	3 steps
		
			14 (0x0E)	14 steps
			15 (0x0F)	15 steps

9.7.3.10 SYSREF_CLR, SYNC_1SHOT_EN, SYNC_POL, SYNC_EN, SYNC_PLL2_DLD, SYNC_PLL1_DLD, SYNC_MODE

This register sets general SYNC parameters such as polarization, and mode. Refer to [Figure 13](#) for block diagram. Refer to [Table 1](#) for using SYNC_MODE for specific SYNC use cases.

Table 32. Register 0x143

BIT	NAME	POR DEFAULT	DESCRIPTION	
7	SYSREF_CLR	1	Except during SYSREF Setup Procedure (see SYNC/SYSREF), this bit should always be programmed to 0. While this bit is set, extra current is used. Refer to Table 84 .	
6	SYNC_1SHOT_EN	0	SYNC one shot enables edge sensitive SYNC. 0: SYNC is level sensitive and outputs will be held in SYNC as long as SYNC is asserted. 1: SYNC is edge sensitive, outputs will be SYNCed on rising edge of SYNC. This results in the clock being held in SYNC for a minimum amount of time.	
5	SYNC_POL	0	Sets the polarity of the SYNC pin. 0: Normal 1: Inverted	
4	SYNC_EN	1	Enables the SYNC functionality. 0: Disabled 1: Enabled	
3	SYNC_PLL2_DLD	0	0: Off 1: Assert SYNC until PLL2 DLD = 1	
2	SYNC_PLL1_DLD	0	0: Off 1: Assert SYNC until PLL1 DLD = 1	
1:0	SYNC_MODE	1	Sets the method of generating a SYNC event.	
			Field Value	SYNC Generation
			0 (0x00)	Prevent SYNC Pin, SYNC_PLL1_DLD flag, or SYNC_PLL2_DLD flag from generating a SYNC event.
			1 (0x01)	SYNC event generated from SYNC pin or if enabled the SYNC_PLL1_DLD flag or SYNC_PLL2_DLD flag.
			2 (0x02)	For use with pulser - SYNC/SYSREF pulses are generated by pulser block via SYNC Pin or if enabled SYNC_PLL1_DLD flag or SYNC_PLL2_DLD flag.
3 (0x03)	For use with pulser - SYNC/SYSREF pulses are generated by pulser block when programming register 0x13E (SYSREF_PULSE_CNT) is written to (see).			

9.7.3.11 SYNC_DISSYSREF, SYNC_DISX

SYNC_DISX will prevent a clock output from being synchronized or interrupted by a SYNC event or when outputting SYSREF.

Table 33. Register 0x144

BIT	NAME	POR DEFAULT	DESCRIPTION
7	SYNC_DISSYSREF	0	Prevent the SYSREF clocks from becoming synchronized during a SYNC event. If SYNC_DISSYSREF is enabled it will continue to operate normally during a SYNC event.
6	SYNC_DIS12	0	Prevent the device clock output from becoming synchronized during a SYNC event or SYSREF clock. If SYNC_DIS bit for a particular output is enabled then it will continue to operate normally during a SYNC event or SYSREF clock.
5	SYNC_DIS10	0	
4	SYNC_DIS8	0	
3	SYNC_DIS6	0	
2	SYNC_DIS4	0	
1	SYNC_DIS2	0	
0	SYNC_DIS0	0	

9.7.3.12 Fixed Register

Always program this register to value 127.

Table 34. Register 0x145

BIT	NAME	POR DEFAULT	DESCRIPTION
7:0	Fixed Register	0	Always program to 127

Always program this register to value 170.

Table 35. Register 0x171

BIT	NAME	POR DEFAULT	DESCRIPTION
7:0	Fixed Register	10 (0x0A)	Always program to 170 (0xAA)

Always program this register to value 2.

Table 36. Register 0x172

BIT	NAME	POR DEFAULT	DESCRIPTION
7:0	Fixed Register	0	Always program to 2 (0x02)

9.7.4 (0x146 - 0x149) CLKIn Control

9.7.4.1 CLKIn2_EN, CLKIn1_EN, CLKIn0_EN, CLKIn2_TYPE, CLKIn1_TYPE, CLKIn0_TYPE

This register has CLKIn enable and type controls.

Table 37. Register 0x146

BIT	NAME	POR DEFAULT	DESCRIPTION
7:6	NA	0	Reserved
5	CLKIn2_EN	0	Enable CLKIn2 to be used during auto-switching of CLKIn_SEL_MODE. 0: Not enabled for auto mode 1: Enabled for auto mode
4	CLKIn1_EN	1	Enable CLKIn1 to be used during auto-switching of CLKIn_SEL_MODE. 0: Not enabled for auto mode 1: Enabled for auto mode

Table 37. Register 0x146 (continued)

BIT	NAME	POR DEFAULT	DESCRIPTION
3	CLKin0_EN	1	Enable CLKin0 to be used during auto-switching of CLKin_SEL_MODE. 0: Not enabled for auto mode 1: Enabled for auto mode
2	CLKin2_TYPE	0	There are two buffer types for CLKin0, 1, and 2: bipolar and CMOS. Bipolar is recommended for differential inputs like LVDS or LVPECL. CMOS is recommended for DC coupled single ended inputs. When using bipolar, CLKinX and CLKinX* must be AC coupled. When using CMOS, CLKinX and CLKinX* may be AC or DC coupled if the input signal is differential. If the input signal is single-ended the used input may be either AC or DC coupled and the unused input must AC grounded.
1	CLKin1_TYPE	0	
0	CLKin0_TYPE	0	

9.7.4.2 CLKin_SEL_POL, CLKin_SEL_MODE, CLKin1_OUT_MUX, CLKin0_OUT_MUX
Table 38. Register 0x147

BIT	NAME	POR DEFAULT	DESCRIPTION	
7	CLKin_SEL_POL	0	Inverts the CLKin polarity for use in pin select mode. 0: Active High 1: Active Low	
6:4	CLKin_SEL_MODE	3	Sets the mode used in determining the reference for PLL1.	
			Field Value	CLKin Mode
			0 (0x00)	CLKin0 Manual
			1 (0x01)	CLKin1 Manual
			2 (0x02)	CLKin2 Manual
			3 (0x03)	Pin Select Mode
			4 (0x04)	Auto Mode
			5 (0x05)	Reserved
3:2	CLKin1_OUT_MUX	2	Selects where the output of the CLKin1 buffer is directed.	
			Field Value	CLKin1 Destination
			0 (0x00)	Fin
			1 (0x01)	Feedback Mux (0-delay mode)
			2 (0x02)	PLL1
1:0	CLKin0_OUT_MUX	2	Selects where the output of the CLKin0 buffer is directed.	
			Field Value	CLKin0 Destination
			0 (0x00)	SYSREF Mux
			1 (0x01)	Reserved
			2 (0x02)	PLL1
			3 (0x03)	Off

9.7.4.3 CLKin_SEL0_MUX, CLKin_SEL0_TYPE

This register has CLKin_SEL0 controls.

Table 39. Register 0x148

BIT	NAME	POR DEFAULT	DESCRIPTION		
7:6	NA	0	Reserved		
5:3	CLKin_SEL0_MUX	0	This set the output value of the CLKin_SEL0 pin. This register only applies if CLKin_SEL0_TYPE is set to an output mode		
			Field Value	Output Format	
			0 (0x00)	Logic Low	
			1 (0x01)	CLKin0 LOS	
			2 (0x02)	CLKin0 Selected	
			3 (0x03)	DAC Locked	
			4 (0x04)	DAC Low	
			5 (0x05)	DAC High	
			6 (0x06)	SPI Readback	
7 (0x07)	Reserved				
2:0	CLKin_SEL0_TYPE	2	This sets the IO type of the CLKin_SEL0 pin.		
			Field Value	Configuration	Function
			0 (0x00)	Input	Input mode, see Input Clock Switching - Pin Select Mode for description of input mode.
			1 (0x01)	Input /w pull-up resistor	
			2 (0x02)	Input /w pull-down resistor	
			3 (0x03)	Output (push-pull)	Output modes; the CLKin_SEL0_MUX register for description of outputs.
			4 (0x04)	Output inverted (push-pull)	
			5 (0x05)	Reserved	
6 (0x06)	Output (open drain)				

9.7.4.4 SDIO_RDBK_TYPE, CLKIn_SEL1_MUX, CLKIn_SEL1_TYPE

This register has CLKIn_SEL1 controls and register readback SDIO pin type.

Table 40. Register 0x149

BIT	NAME	POR DEFAULT	DESCRIPTION		
7	NA	0	Reserved		
6	SDIO_RDBK_TYPE	1	Sets the SDIO pin to open drain when during SPI readback in 3 wire mode. 0: Output, push-pull 1: Output, open drain.		
5:3	CLKIn_SEL1_MUX	0	This set the output value of the CLKIn_SEL1 pin. This register only applies if CLKIn_SEL1_TYPE is set to an output mode.		
			Field Value	Output Format	
			0 (0x00)	Logic Low	
			1 (0x01)	CLKIn1 LOS	
			2 (0x02)	CLKIn1 Selected	
			3 (0x03)	DAC Locked	
			4 (0x04)	DAC Low	
			5 (0x05)	DAC High	
			6 (0x06)	SPI Readback	
7 (0x07)	Reserved				
2:0	CLKIn_SEL1_TYPE	2	This sets the IO type of the CLKIn_SEL1 pin.		
			Field Value	Configuration	Function
			0 (0x00)	Input	Input mode, see Input Clock Switching - Pin Select Mode for description of input mode.
			1 (0x01)	Input /w pull-up resistor	
			2 (0x02)	Input /w pull-down resistor	
			3 (0x03)	Output (push-pull)	Output modes; see the CLKIn_SEL1_MUX register for description of outputs.
			4 (0x04)	Output inverted (push-pull)	
			5 (0x05)	Reserved	
6 (0x06)	Output (open drain)				

9.7.5 RESET_MUX, RESET_TYPE

This register contains control of the RESET pin.

Table 41. Register 0x14A

BIT	NAME	POR DEFAULT	DESCRIPTION		
7:6	NA	0	Reserved		
5:3	RESET_MUX	0	This sets the output value of the RESET pin. This register only applies if RESET_TYPE is set to an output mode.		
			Field Value	Output Format	
			0 (0x00)	Logic Low	
			1 (0x01)	Reserved	
			2 (0x02)	CLKin2 Selected	
			3 (0x03)	DAC Locked	
			4 (0x04)	DAC Low	
			5 (0x05)	DAC High	
6 (0x06)	SPI Readback				
2:0	RESET_TYPE	2	This sets the IO type of the RESET pin.		
			Field Value	Configuration	Function
			0 (0x00)	Input	Reset Mode Reset pin high = Reset
			1 (0x01)	Input /w pull-up resistor	
			2 (0x02)	Input /w pull-down resistor	
			3 (0x03)	Output (push-pull)	Output modes; see the RESET_MUX register for description of outputs.
			4 (0x04)	Output inverted (push-pull)	
			5 (0x05)	Reserved	
6 (0x06)	Output (open drain)				

9.7.6 (0x14B - 0x152) Holdover

9.7.6.1 LOS_TIMEOUT, LOS_EN, TRACK_EN, HOLDOVER_FORCE, MAN_DAC_EN, MAN_DAC[9:8]

This register contains the holdover functions.

Table 42. Register 0x14B

BIT	NAME	POR DEFAULT	DESCRIPTION	
7:6	LOS_TIMEOUT	0	This controls the amount of time in which no activity on a CLKin forces a clock switch event.	
			Field Value	Timeout
			0 (0x00)	370 kHz
			1 (0x01)	2.1 MHz
			2 (0x02)	8.8 MHz
			3 (0x03)	22 MHz
5	LOS_EN	0	Enables the LOS (Loss-of-Signal) timeout control. Valid for MOS clock inputs. 0: Disabled 1: Enabled	
4	TRACK_EN	1	Enable the DAC to track the PLL1 tuning voltage, optionally for use in holdover mode. After device reset, tracking starts at DAC code = 512. Tracking can be used to monitor PLL1 voltage in any mode. 0: Disabled 1: Enabled, will only track when PLL1 is locked.	
3	HOLDOVER_FORCE	0	This bit forces holdover mode. When holdover mode is forced, if MAN_DAC_EN = 1, then the DAC will set the programmed MAN_DAC value. Otherwise the tracked DAC value will set the DAC voltage. 0: Disabled 1: Enabled.	
2	MAN_DAC_EN	1	This bit enables the manual DAC mode. 0: Automatic 1: Manual	
1:0	MAN_DAC[9:8]	2	See MAN_DAC[9:8] , MAN_DAC[7:0] for more information on the MAN_DAC settings.	

9.7.6.2 MAN_DAC[9:8], MAN_DAC[7:0]

These registers set the value of the DAC in holdover mode when used manually.

Table 43. MAN_DAC[9:0]

MSB		LSB	
0x14B[1:0]		0x14C[7:0]	

BIT	REGISTERS	NAME	POR DEFAULT	DESCRIPTION	
7:2	0x14B			See LOS_TIMEOUT , LOS_EN , TRACK_EN , HOLDOVER_FORCE , MAN_DAC_EN , MAN_DAC[9:8] for information on these bits.	
1:0	0x14B	MAN_DAC[9:8]	2	Sets the value of the manual DAC when in manual DAC mode.	
				Field Value	DAC Value
				0 (0x00)	0
				1 (0x01)	1
7:0	0x14C	MAN_DAC[7:0]	0	2 (0x02)	
			
				1022 (0x3FE)	1022
				1023 (0x3FF)	1023

9.7.6.3 DAC_TRIP_LOW

This register contains the high value at which holdover mode is entered.

Table 44. Register 0x14D

BIT	NAME	POR DEFAULT	DESCRIPTION	
7:6	NA	0	Reserved	
5:0	DAC_TRIP_LOW	0	Voltage from GND at which holdover is entered if HOLDOVER_VTUNE_DET is enabled.	
			Field Value	DAC Trip Value
			0 (0x00)	1 x Vcc / 64
			1 (0x01)	2 x Vcc / 64
			2 (0x02)	3 x Vcc / 64
			3 (0x03)	4 x Vcc / 64
		
			61 (0x17)	62 x Vcc / 64
			62 (0x18)	63 x Vcc / 64
	63 (0x19)	64 x Vcc / 64		

9.7.6.4 DAC_CLK_MULT, DAC_TRIP_HIGH

This register contains the multiplier for the DAC clock counter and the low value at which holdover mode is entered.

Table 45. Register 0x14E

BIT	NAME	POR DEFAULT	DESCRIPTION	
7:6	DAC_CLK_MULT	0	This is the multiplier for the DAC_CLK_CNTR which sets the rate at which the DAC value is tracked.	
			Field Value	DAC Multiplier Value
			0 (0x00)	4
			1 (0x01)	64
			2 (0x02)	1024
			3 (0x03)	16384
5:0	DAC_TRIP_HIGH	0	Voltage from Vcc at which holdover is entered if HOLDOVER_VTUNE_DET is enabled.	
			Field Value	DAC Trip Value
			0 (0x00)	1 x Vcc / 64
			1 (0x01)	2 x Vcc / 64
			2 (0x02)	3 x Vcc / 64
			3 (0x03)	4 x Vcc / 64
		
			61 (0x17)	62 x Vcc / 64
			62 (0x18)	63 x Vcc / 64
			63 (0x19)	64 x Vcc / 64

9.7.6.5 DAC_CLK_CNTR

This register contains the value of the DAC when in tracked mode.

Table 46. Register 0x14F

BIT	NAME	POR DEFAULT	DESCRIPTION	
7:0	DAC_CLK_CNTR	127	This with DAC_CLK_MULT set the rate at which the DAC is updated. The update rate is = DAC_CLK_MULT * DAC_CLK_CNTR / PLL1 PDF	
			Field Value	DAC Value
			0 (0x00)	0
			1 (0x01)	1
			2 (0x02)	2
			3 (0x03)	3
		
			253 (0xFD)	253
			254 (0xFE)	254
			255 (0xFF)	255

9.7.6.6 CLKin_OVERRIDE, HOLDOVER_PLL1_DET, HOLDOVER_LOS_DET, HOLDOVER_VTUNE_DET, HOLDOVER_HITLESS_SWITCH, HOLDOVER_EN

This register has controls for enabling clock in switch events.

Table 47. Register 0x150

BIT	NAME	POR DEFAULT	DESCRIPTION
7	NA	0	Reserved
6	CLKin_OVERRIDE	0	When CLKin_SEL_MODE = 0/1/2 to select a manual clock input, CLKin_OVERRIDE = 1 will force that clock input. Used with clock distribution mode for best performance. 0: Normal, no override. 1: Force select of only CLKin0/1/2 as specified by CLKin_SEL_MODE in manual mode.
5	NA	0	Reserved
4	HOLDOVER_PLL1_DET	0	This enables the HOLDOVER when PLL1 lock detect signal transitions from high to low. 0: PLL1 DLD does not cause a clock switch event 1: PLL1 DLD causes a clock switch event
3	HOLDOVER_LOS_DET	0	This enables HOLDOVER when PLL1 LOS signal is detected. 0: Disabled 1: Enabled
2	HOLDOVER_VTUNE_DET	0	Enables the DAC Vtune rail detections. When the DAC achieves a specified Vtune, if this bit is enabled, the current clock input is considered invalid and an input clock switch event is generated. 0: Disabled 1: Enabled
1	HOLDOVER_HITLESS_SWITCH	1	Determines whether a clock switch event will enter holdover use hitless switching. 0: Hard Switch 1: Hitless switching (has an undefined switch time)
0	HOLDOVER_EN	1	Sets whether holdover mode is active or not. 0: Disabled 1: Enabled

9.7.6.7 HOLDOVER_DLD_CNT[13:8], HOLDOVER_DLD_CNT[7:0]
Table 48. HOLDOVER_DLD_CNT[13:0]

MSB	LSB
0x151[5:0]	0x152[7:0]

This register has the number of valid clocks of PLL1 PDF before holdover is exited.

Table 49. Registers 0x151 and 0x152

BIT	REGISTERS	NAME	POR DEFAULT	DESCRIPTION	
7:6	0x151	NA	0	Reserved	
5:0	0x151	HOLDOVER_DLD_CNT[13:8]	2	The number of valid clocks of PLL1 PDF before holdover mode is exited.	
				Field Value	Count Value
				0 (0x00)	0
				1 (0x01)	1
7:0	0x152	HOLDOVER_DLD_CNT[7:0]	0	2 (0x02)	
			
				16382 (0x3FFE)	16382
				16383 (0x3FFF)	16383

9.7.7 (0x153 - 0x15F) PLL1 Configuration

9.7.7.1 CLKin0_R[13:8], CLKin0_R[7:0]

Table 50. CLKin0_R[13:0]

MSB	LSB
0x153[5:0]	0x154[7:0]

These registers contain the value of the CLKin0 divider.

BIT	REGISTERS	NAME	POR DEFAULT	DESCRIPTION	
7:6	0x153	NA	0	Reserved	
5:0	0x153	CLKin0_R[13:8]	0	The value of PLL1 N counter when CLKin0 is selected.	
				Field Value	Divide Value
				0 (0x00)	Reserved
				1 (0x01)	1
7:0	0x154	CLKin0_R[7:0]	120	2 (0x02)	
			
				16382 (0x3FFE)	16382
				16383 (0x3FFF)	16383

9.7.7.2 CLKin1_R[13:8], CLKin1_R[7:0]

Table 51. CLKin1_R[13:0]

MSB	LSB
0x155[5:0]	0x156[7:0]

These registers contain the value of the CLKin1 R divider.

Table 52. Registers 0x155 and 0x156

BIT	REGISTERS	NAME	POR DEFAULT	DESCRIPTION	
7:6	0x155	NA	0	Reserved	
5:0	0x155	CLKin1_R[13:8]	0	The value of PLL1 N counter when CLKin1 is selected.	
				Field Value	Divide Value
				0 (0x00)	Reserved
				1 (0x01)	1
7:0	0x156	CLKin1_R[7:0]	150	2 (0x02)	
			
				16382 (0x3FFE)	16382
				16383 (0x3FFF)	16383

9.7.7.3 CLKin2_R[13:8], CLKin2_R[7:0]

MSB	LSB
0x157[5:0]	0x158[7:0]

Table 53. Registers 0x157 and 0x158

BIT	REGISTERS	NAME	POR DEFAULT	DESCRIPTION	
7:6	0x157	NA	0	Reserved	
5:0	0x157	CLKin2_R[13:8]	0	The value of PLL1 N counter when CLKin2 is selected.	
				Field Value	Divide Value
				0 (0x00)	Reserved
7:0	0x158	CLKin2_R[7:0]	150	1 (0x01)	1
				2 (0x02)	2
			
				16382 (0x3FFE)	16382
				16383 (0x3FFF)	16383

9.7.7.4 PLL1_N
Table 54. PLL1_N[13:8], PLL1_N[7:0]

PLL1_N[13:0]	
MSB	LSB
0x159[5:0]	0x15A[7:0]

These registers contain the N divider value for PLL1.

Table 55. Registers 0x159 and 0x15A

BIT	REGISTERS	NAME	POR DEFAULT	DESCRIPTION	
7:6	0x159	NA	0	Reserved	
5:0	0x159	PLL1_N[13:8]	0	The value of PLL1 N counter.	
				Field Value	Divide Value
				0 (0x00)	Not Valid
7:0	0x15A	PLL1_N[7:0]	120	1 (0x01)	1
				2 (0x02)	2
			
				4,095 (0xFFF)	4,095

9.7.7.5 PLL1_WND_SIZE, PLL1_CP_TRI, PLL1_CP_POL, PLL1_CP_GAIN

This register controls the PLL1 phase detector.

Table 56. Register 0x15B

BIT	NAME	POR DEFAULT	DESCRIPTION	
7:6	PLL1_WND_SIZE	3	PLL1_WND_SIZE sets the window size used for digital lock detect for PLL1. If the phase error between the reference and feedback of PLL1 is less than specified time, then the PLL1 lock counter increments.	
			Field Value	Definition
			0 (0x00)	4 ns
			1 (0x01)	9 ns
			2 (0x02)	19 ns
			3 (0x03)	43 ns
5	PLL1_CP_TRI	0	This bit allows for the PLL1 charge pump output pin, CPout1, to be placed into TRI-STATE. 0: PLL1 CPout1 is active 1: PLL1 CPout1 is at TRI-STATE	
4	PLL1_CP_POL	1	PLL1_CP_POL sets the charge pump polarity for PLL1. Many VCXOs use positive slope. A positive slope VCXO increases output frequency with increasing voltage. A negative slope VCXO decreases output frequency with increasing voltage. 0: Negative Slope VCO/VCXO 1: Positive Slope VCO/VCXO	
3:0	PLL1_CP_GAIN	4	This bit programs the PLL1 charge pump output current level.	
			Field Value	Gain
			0 (0x00)	50 μ A
			1 (0x01)	150 μ A
			2 (0x02)	250 μ A
			3 (0x03)	350 μ A
			4 (0x04)	450 μ A
		
14 (0x0E)	1450 μ A			
			15 (0x0F)	1550 μ A

9.7.7.6 PLL1_DLD_CNT[13:8], PLL1_DLD_CNT[7:0]
Table 57. PLL1_DLD_CNT[13:0]

MSB	LSB
0x15C[5:0]	0x15D[7:0]

This register contains the value of the PLL1 DLD counter.

Table 58. Registers 0x15C and 0x15D

BIT	REGISTERS	NAME	POR DEFAULT	DESCRIPTION	
7:6	0x15C	NA	0	Reserved	
5:0	0x15C	PLL1_DLD_CNT[13:8]	32	The reference and feedback of PLL1 must be within the window of phase error as specified by PLL1_WND_SIZE for this many phase detector cycles before PLL1 digital lock detect is asserted.	
				Field Value	Delay Value
				0 (0x00)	Reserved
				1 (0x01)	1
7:0	0x15D	PLL1_DLD_CNT[7:0]	0	2 (0x02)	2
				3 (0x03)	3
			
				16,382 (0x3FFE)	16,382
				16,383 (0x3FFF)	16,383

9.7.7.7 PLL1_R_DLY, PLL1_N_DLY

This register contains the delay value for PLL1 N and R delays.

Table 59. Register 0x15E

BIT	NAME	POR DEFAULT	DESCRIPTION	
7:6	NA	0	Reserved	
5:3	PLL1_R_DLY	0	Increasing delay of PLL1_R_DLY will cause the outputs to lag from CLKinX. For use in 0-delay mode.	
			Field Value	Gain
			0 (0x00)	0 ps
			1 (0x01)	205 ps
			2 (0x02)	410 ps
			3 (0x03)	615 ps
			4 (0x04)	820 ps
			5 (0x05)	1025 ps
			6 (0x06)	1230 ps
7 (0x07)	1435 ps			
2:0	PLL1_N_DLY	0	Increasing delay of PLL1_N_DLY will cause the outputs to lead from CLKinX. For use in 0-delay mode.	
			Field Value	Gain
			0 (0x00)	0 ps
			1 (0x01)	205 ps
			2 (0x02)	410 ps
			3 (0x03)	615 ps
			4 (0x04)	820 ps
			5 (0x05)	1025 ps
			6 (0x06)	1230 ps
7 (0x07)	1435 ps			

9.7.7.8 PLL1_LD_MUX, PLL1_LD_TYPE

This register configures the PLL1 LD pin.

Table 60. Register 0x15F

BIT	NAME	POR DEFAULT	DESCRIPTION	
7:3	PLL1_LD_MUX	1	This sets the output value of the Status_LD1 pin.	
			Field Value	MUX Value
			0 (0x00)	Logic Low
			1 (0x01)	PLL1 DLD
			2 (0x02)	PLL2 DLD
			3 (0x03)	PLL1 & PLL2 DLD
			4 (0x04)	Holdover Status
			5 (0x05)	DAC Locked
			6 (0x06)	Reserved
			7 (0x07)	SPI Readback
			8 (0x08)	DAC Rail
			9 (0x09)	DAC Low
			10 (0x0A)	DAC High
			11 (0x0B)	PLL1_N
			12 (0x0C)	PLL1_N/2
			13 (0x0D)	PLL2_N
			14 (0x0E)	PLL2_N/2
			15 (0x0F)	PLL1_R
			16 (0x10)	PLL1_R/2
17 (0x11)	PLL2_R ⁽¹⁾			
18 (0x12)	PLL2_R/2 ⁽¹⁾			
2:0	PLL1_LD_TYPE	6	Sets the IO type of the Status_LD1 pin.	
			Field Value	TYPE
			0 (0x00)	Reserved
			1 (0x01)	Reserved
			2 (0x02)	Reserved
			3 (0x03)	Output (push-pull)
			4 (0x04)	Output inverted (push-pull)
			5 (0x05)	Reserved
6 (0x06)	Output (open drain)			

(1) Only valid when PLL2_LD_MUX is not set to 2 (PLL2_DLD) or 3 (PLL1 & PLL2 DLD).

9.7.8 (0x160 - 0x16E) PLL2 Configuration

9.7.8.1 PLL2_R[11:8], PLL2_R[7:0]

Table 61. PLL2_R[11:0]

MSB	LSB
0x160[3:0]	0x161[7:0]

This register contains the value of the PLL2 R divider.

Table 62. Registers 0x160 and 0x161

BIT	REGISTERS	NAME	POR DEFAULT	DESCRIPTION	
7:4	0x160	NA	0	Reserved	
3:0	0x160	PLL2_R[11:8]	0	Valid values for the PLL2 R divider.	
				Field Value	Divide Value
				0 (0x00)	Not Valid
				1 (0x01)	1
7:0	0x161	PLL2_R[7:0]	2	2 (0x02)	
				3 (0x03)	2
				...	3
				4,094 (0xFFE)	...
				4,095 (0xFFFF)	4,094
					4,095

9.7.8.2 PLL2_P, OSCin_FREQ, PLL2_XTAL_EN, PLL2_REF_2X_EN

This register sets other PLL2 functions.

Table 63. Register 0x162

BIT	NAME	POR DEFAULT	DESCRIPTION	
7:5	PLL2_P	2	The PLL2 N Prescaler divides the output of the VCO as selected by Mode_MUX1 and is connected to the PLL2 N divider.	
			Field Value	Value
			0 (0x00)	8
			1 (0x01)	2
			2 (0x02)	2
			3 (0x03)	3
			4 (0x04)	4
			5 (0x05)	5
			6 (0x06)	6
7 (0x07)	7			
4:2	OSCin_FREQ	7	The frequency of the PLL2 reference input to the PLL2 Phase Detector (OSCin/OSCin* port) must be programmed in order to support proper operation of the frequency calibration routine which locks the internal VCO to the target frequency.	
			Field Value	OSCin Frequency
			0 (0x00)	0 to 63 MHz
			1 (0x01)	>63 MHz to 127 MHz
			2 (0x02)	>127 MHz to 255 MHz
			3 (0x03)	Reserved
			4 (0x04)	>255 MHz to 500 MHz
5 (0x05) to 7(0x07)	Reserved			
1	PLL2_XTAL_EN	0	If an external crystal is being used to implement a discrete VCXO, the internal feedback amplifier must be enabled with this bit in order to complete the oscillator circuit. 0: Oscillator Amplifier Disabled 1: Oscillator Amplifier Enabled	
0	PLL2_REF_2X_EN	1	Enabling the PLL2 reference frequency doubler allows for higher phase detector frequencies on PLL2 than would normally be allowed with the given VCXO or Crystal frequency. Higher phase detector frequencies reduces the PLL N values which makes the design of wider loop bandwidth filters possible. 0: Doubler Disabled 1: Doubler Enabled	

9.7.8.3 PLL2_N_CAL

PLL2_N_CAL[17:0]

PLL2 never uses 0-delay during frequency calibration. These registers contain the value of the PLL2 N divider used with PLL2 pre-scaler during calibration for cascaded 0-delay mode. Once calibration is complete, PLL2 will use PLL2_N value. Cascaded 0-delay mode occurs when PLL2_NCLK_MUX = 1.

Table 64. Register 0x162

MSB	—	LSB
0x163[1:0]	0x164[7:0]	0x165[7:0]

Table 65. Registers 0x163, 0x164, and 0x165

BIT	REGISTERS	NAME	POR DEFAULT	DESCRIPTION	
7:2	0x163	NA	0	Reserved	
1:0	0x163	PLL2_N_CAL[17:16]	0	Field Value	Divide Value
				0 (0x00)	Not Valid
7:0	0x164	PLL2_N_CAL[15:8]	0	1 (0x01)	1
				2 (0x02)	2
7:0	0x165	PLL2_N_CAL[7:0]	12
				262,143 (0x3FFFF)	262,143

9.7.8.4 PLL2_FCAL_DIS, PLL2_N

This register disables frequency calibration and sets the PLL2 N divider value. Programming register 0x168 starts a VCO calibration routine if PLL2_FCAL_DIS = 0.

Table 66. PLL2_N[17:0]

MSB	—	LSB
0x166[1:0]	0x167[7:0]	0x168[7:0]

Table 67. Registers 0x166, 0x167, and 0x168

BIT	REGISTERS	NAME	POR DEFAULT	DESCRIPTION	
7:3	0x166	NA	0	Reserved	
2	0x166	PLL2_FCAL_DIS	0	This disables the PLL2 frequency calibration on programming register 0x168. 0: Frequency calibration enabled 1: Frequency calibration disabled	
1:0	0x166	PLL2_N[17:16]	0	Field Value	Divide Value
				0 (0x00)	Not Valid
7:0	0x167	PLL2_N[15:8]	0	1 (0x01)	1
				2 (0x02)	2
7:0	0x168	PLL2_N[7:0]	12
				262,143 (0x3FFFF)	262,143

9.7.8.5 PLL2_WND_SIZE, PLL2_CP_GAIN, PLL2_CP_POL, PLL2_CP_TRI

This register controls the PLL2 phase detector.

Table 68. Register 0x169

BIT	NAME	POR DEFAULT	DESCRIPTION	
7	NA	0	Reserved	
6:5	PLL2_WND_SIZE	2	PLL2_WND_SIZE sets the window size used for digital lock detect for PLL2. If the phase error between the reference and feedback of PLL2 is less than specified time, then the PLL2 lock counter increments. This value must be programmed to 2 (3.7 ns).	
			Field Value	Definition
			0 (0x00)	Reserved
			1 (0x01)	Reserved
			2 (0x02)	3.7 ns
			3 (0x03)	Reserved
4:3	PLL2_CP_GAIN	3	This bit programs the PLL2 charge pump output current level. The table below also illustrates the impact of the PLL2 TRISTATE bit in conjunction with PLL2_CP_GAIN.	
			Field Value	Definition
			0 (0x00)	100 μ A
			1 (0x01)	400 μ A
			2 (0x02)	1600 μ A
			3 (0x03)	3200 μ A
2	PLL2_CP_POL	0	PLL2_CP_POL sets the charge pump polarity for PLL2. The internal VCO requires the negative charge pump polarity to be selected. Many VCOs use positive slope. A positive slope VCO increases output frequency with increasing voltage. A negative slope VCO decreases output frequency with increasing voltage.	
			Field Value	Description
			0	Negative Slope VCO/VCXO
			1	Positive Slope VCO/VCXO
1	PLL2_CP_TRI	0	PLL2_CP_TRI TRI-STATes the output of the PLL2 charge pump. 0: Disabled 1: TRI-STATE	
0	Fixed Value	1	When programming register 0x169, this field must be set to 1.	

9.7.8.6 SYSREF_REQ_EN, PLL2_DLD_CNT
Table 69. PLL2_DLD_CNT[15:0]

MSB	LSB
0x16A[5:0]	0x16B[7:0]

This register has the value of the PLL2 DLD counter.

Table 70. Registers 0x16A and 0x16B

BIT	REGISTERS	NAME	POR DEFAULT	DESCRIPTION	
7	0x16A	NA	0	Reserved	
6	0x16A	SYSREF_REQ_EN	0	Enables the SYNC/SYSREF_REQ pin to force the SYSREF_MUX = 3 for continuous pulses. When using this feature enable pulser and set SYSREF_MUX = 2 (Pulser).	
5:0	0x16A	PLL2_DLD_CNT[13:8]	32	The reference and feedback of PLL2 must be within the window of phase error as specified by PLL2_WND_SIZE for PLL2_DLD_CNT cycles before PLL2 digital lock detect is asserted.	
				Field Value	Divide Value
				0 (0x00)	Not Valid
				1 (0x01)	1
7:0	0x16B	PLL2_DLD_CNT	0	2 (0x02)	2
				3 (0x03)	3
			
				16,382 (0x3FFE)	16,382
				16,383 (0x3FFF)	16,383

9.7.8.7 PLL2_LF_R4, PLL2_LF_R3

This register controls the integrated loop filter resistors.

Table 71. Register 0x16C

BIT	NAME	POR DEFAULT	DESCRIPTION	
7:6	NA	0	Reserved	
5:3	PLL2_LF_R4	0	Internal loop filter components are available for PLL2, enabling either 3rd or 4th order loop filters without requiring external components. Internal loop filter resistor R4 can be set according to the following table.	
			Field Value	Resistance
			0 (0x00)	200 Ω
			1 (0x01)	1 kΩ
			2 (0x02)	2 kΩ
			3 (0x03)	4 kΩ
			4 (0x04)	16 kΩ
			5 (0x05)	Reserved
			6 (0x06)	Reserved
7 (0x07)	Reserved			
2:0	PLL2_LF_R3	0	Internal loop filter components are available for PLL2, enabling either 3rd or 4th order loop filters without requiring external components. Internal loop filter resistor R3 can be set according to the following table.	
			Field Value	Resistance
			0 (0x00)	200 Ω
			1 (0x01)	1 kΩ
			2 (0x02)	2 kΩ
			3 (0x03)	4 kΩ
			4 (0x04)	16 kΩ
			5 (0x05)	Reserved
			6 (0x06)	Reserved
7 (0x07)	Reserved			

9.7.8.8 PLL2_LF_C4, PLL2_LF_C3

This register controls the integrated loop filter capacitors.

Table 72. Register 0x16D

BIT	NAME	POR DEFAULT	DESCRIPTION	
7:4	PLL2_LF_C4	0	Internal loop filter components are available for PLL2, enabling either 3rd or 4th order loop filters without requiring external components. Internal loop filter capacitor C4 can be set according to the following table.	
			Field Value	Resistance
			0 (0x00)	10 pF
			1 (0x01)	15 pF
			2 (0x02)	29 pF
			3 (0x03)	34 pF
			4 (0x04)	47 pF
			5 (0x05)	52 pF
			6 (0x06)	66 pF
			7 (0x07)	71 pF
			8 (0x08)	103 pF
			9 (0x09)	108 pF
			10 (0x0A)	122 pF
			11 (0x0B)	126 pF
			12 (0x0C)	141 pF
			13 (0x0D)	146 pF
14 (0x0E)	Reserved			
15 (0x0F)	Reserved			
3:0	PLL2_LF_C3	0	Internal loop filter components are available for PLL2, enabling either 3rd or 4th order loop filters without requiring external components. Internal loop filter capacitor C3 can be set according to the following table.	
			Field Value	Resistance
			0 (0x00)	10 pF
			1 (0x01)	11 pF
			2 (0x02)	15 pF
			3 (0x03)	16 pF
			4 (0x04)	19 pF
			5 (0x05)	20 pF
			6 (0x06)	24 pF
			7 (0x07)	25 pF
			8 (0x08)	29 pF
			9 (0x09)	30 pF
			10 (0x0A)	33 pF
			11 (0x0B)	34 pF
			12 (0x0C)	38 pF
			13 (0x0D)	39 pF
14 (0x0E)	Reserved			
15 (0x0F)	Reserved			

9.7.8.9 PLL2_LD_MUX, PLL2_LD_TYPE

This register sets the output value of the Status_LD2 pin.

Table 73. Register 0x16E

BIT	NAME	POR DEFAULT	DESCRIPTION	
7:3	PLL2_LD_MUX	2	This sets the output value of the Status_LD2 pin.	
			Field Value	MUX Value
			0 (0x00)	Logic Low
			1 (0x01)	PLL1 DLD
			2 (0x02)	PLL2 DLD
			3 (0x03)	PLL1 & PLL2 DLD
			4 (0x04)	Holdover Status
			5 (0x05)	DAC Locked
			6 (0x06)	Reserved
			7 (0x07)	SPI Readback
			8 (0x08)	DAC Rail
			9 (0x09)	DAC Low
			10 (0x0A)	DAC High
			11 (0x0B)	PLL1_N
			12 (0x0C)	PLL1_N/2
			13 (0x0D)	PLL2_N
			14 (0x0E)	PLL2_N/2
			15 (0x0F)	PLL1_R
			16 (0x10)	PLL1_R/2
17 (0x11)	PLL2_R ⁽¹⁾			
18 (0x12)	PLL2_R/2 ⁽¹⁾			
2:0	PLL2_LD_TYPE	6	Sets the IO type of the Status_LD2 pin.	
			Field Value	TYPE
			0 (0x00)	Reserved
			1 (0x01)	Reserved
			2 (0x02)	Reserved
			3 (0x03)	Output (push-pull)
			4 (0x04)	Output inverted (push-pull)
			5 (0x05)	Reserved
6 (0x06)	Output (open drain)			

(1) Only valid when PLL1_LD_MUX is not set to 2 (PLL2_DLD) or 3 (PLL1 & PLL2 DLD).

9.7.9 (0x16F - 0x1FFF) Misc Registers

9.7.9.1 PLL2_PRE_PD, PLL2_PD

Table 74. Register 0x173

BIT	NAME	DESCRIPTION
7	N/A	Reserved
6	PLL2_PRE_PD	Powerdown PLL2 prescaler 0: Normal Operation 1: Powerdown
5	PLL2_PD	Powerdown PLL2 0: Normal Operation 1: Powerdown
4:0	N/A	Reserved

9.7.9.2 VCO1_DIV

Sets VCO1 VCO divider value. This divider cannot be bypassed and has a minimum value of 2. This register is reserved for LMK04826 and LMK04828 and should be left unprogrammed.

Table 75. Register 0x174

BIT	NAME	POR DEFAULT	DESCRIPTION	
7:5	N/A	0	Reserved	
4:0	VCO1_DIV (LMK04821 only)	0	When VCO_MUX selects VCO1 for LMK04821, the clock distribution frequency will be equal to VCO1 frequency divided by this divide value. Note this divider is also on the PLL2 feedback path and will impact PLL2 N divider value. Unlisted field values are reserved.	
			Field Value	Divide Value
			0 (0x00)	2
			5 (0x05)	3
			10 (0x0A)	8
			20 (0x14)	4
			23 (0x17)	5
			27 (0x1B)	7
			30 (0x1E)	6

9.7.9.3 OPT_REG_1

This register must be written with the following value depending on which LMK0482x family part is used to optimize VCO1 phase noise performance over temperature. This register must be written before writing register 0x168 when using VCO1.

Table 76. Register 0x17C

BIT	NAME	DESCRIPTION
7:0	OPT_REG_1	21: LMK04821 24: LMK04826 21: LMK04828

9.7.9.4 OPT_REG_2

This register must be written with the following value depending on which LMK0482x family part is used to optimize VCO1 phase noise performance over temperature. This register must be written before writing register 0x168 when using VCO1.

Table 77. Register 0x17D

BIT	NAME	DESCRIPTION
7:0	OPT_REG_2	51: LMK04821 119: LMK04826 51: LMK04828

9.7.9.5 RB_PLL1_LD_LOST, RB_PLL1_LD, CLR_PLL1_LD_LOST

Table 78. Register 0x182

BIT	NAME	DESCRIPTION
7:3	N/A	Reserved
2	RB_PLL1_LD_LOST	This is set when PLL1 DLD edge falls. Does not set if cleared while PLL1 DLD is low.
1	RB_PLL1_LD	Read back 0: PLL1 DLD is low. Read back 1: PLL1 DLD is high.
0	CLR_PLL1_LD_LOST	To reset RB_PLL1_LD_LOST, write CLR_PLL1_LD_LOST with 1 and then 0. 0: RB_PLL1_LD_LOST will be set on next falling PLL1 DLD edge. 1: RB_PLL1_LD_LOST is held clear (0). User must clear this bit to allow RB_PLL1_LD_LOST to become set again.

9.7.9.6 RB_PLL2_LD_LOST, RB_PLL2_LD, CLR_PLL2_LD_LOST

Table 79. Register 0x0x183

BIT	NAME	DESCRIPTION
7:3	N/A	Reserved
2	RB_PLL2_LD_LOST	This is set when PLL2 DLD edge falls. Does not set if cleared while PLL2 DLD is low.
1	RB_PLL2_LD	PLL1_LD_MUX or PLL2_LD_MUX must select setting 2 (PLL2 DLD) for valid reading of this bit. Read back 0: PLL2 DLD is low. Read back 1: PLL2 DLD is high.
0	CLR_PLL2_LD_LOST	To reset RB_PLL2_LD_LOST, write CLR_PLL2_LD_LOST with 1 and then 0. 0: RB_PLL2_LD_LOST will be set on next falling PLL2 DLD edge. 1: RB_PLL2_LD_LOST is held clear (0). User must clear this bit to allow RB_PLL2_LD_LOST to become set again.

9.7.9.7 **RB_DAC_VALUE(MSB), RB_CLKinX_SEL, RB_CLKinX_LOS**

This register provides read back access to CLKinX selection indicator and CLKinX LOS indicator. The 2 MSBs are shared with the RB_DAC_VALUE. See RB_DAC_VALUE section.

Table 80. Register 0x184

BIT	NAME	DESCRIPTION
7:6	RB_DAC_VALUE[9:8]	See RB_DAC_VALUE section.
5	RB_CLKin2_SEL	Read back 0: CLKin2 is not selected for input to PLL1. Read back 1: CLKin2 is selected for input to PLL1.
4	RB_CLKin1_SEL	Read back 0: CLKin1 is not selected for input to PLL1. Read back 1: CLKin1 is selected for input to PLL1.
3	RB_CLKin0_SEL	Read back 0: CLKin0 is not selected for input to PLL1. Read back 1: CLKin0 is selected for input to PLL1.
2	N/A	
1	RB_CLKin1_LOS	Read back 1: CLKin1 LOS is active. Read back 0: CLKin1 LOS is not active.
0	RB_CLKin0_LOS	Read back 1: CLKin0 LOS is active. Read back 0: CLKin0 LOS is not active.

9.7.9.8 **RB_DAC_VALUE**

Contains the value of the DAC for user readback.

FIELD NAME	MSB	LSB
RB_DAC_VALUE	0x184 [7:6]	0x185 [7:0]

Table 81. Registers 0x184 and 0x185

BIT	REGISTERS	NAME	POR DEFAULT	DESCRIPTION
7:6	0x184	RB_DAC_VALUE[9:8]	2	DAC value is 512 on power on reset, if PLL1 locks upon power-up the DAC value will change.
7:0	0x185	RB_DAC_VALUE[7:0]	0	

9.7.9.9 **RB_HOLDOVER**

Table 82. Register 0x188

BIT	NAME	DESCRIPTION
7:5	N/A	Reserved
4	RB_HOLDOVER	Read back 0: Not in HOLDOVER. Read back 1: In HOLDOVER.
3:0	N/A	Reserved

9.7.9.10 SPI_LOCK

Prevents SPI registers from being written to, except for 0x1FFD, 0x1FFE, 0x1FFF. These registers must be written to sequentially and in order: 0x1FFD, 0x1FFE, 0x1FFF.

These registers cannot be read back.

MSB	—	LSB
0x1FFD [7:0]	0x1FFE [7:0]	0x1FFF [7:0]

Table 83. Registers 0x1FFD, 0x1FFE, and 0x1FFF

BIT	REGISTERS	NAME	POR DEFAULT	DESCRIPTION
7:0	0x1FFD	SPI_LOCK[23:16]	0	0: Registers unlocked. 1 to 255: Registers locked
7:0	0x1FFE	SPI_LOCK[15:8]	0	0: Registers unlocked. 1 to 255: Registers locked
7:0	0x1FFF	SPI_LOCK[7:0]	83	0 to 82: Registers locked 83: Registers unlocked 84 to 256: Registers locked

10 Applications and Implementation

10.1 Application Information

To assist customers in frequency planning and design of loop filters Texas Instrument's provides the Clock Design Tool (www.ti.com/tool/clockdesigntool) and Clock Architect (www.ti.com/clockarchitect).

10.2 Typical Applications

10.2.1 Digital Lock Detect Frequency Accuracy

The digital lock detect circuit is used to determine PLL1 locked, PLL2 locked, and holdover exit events. A window size and lock count register are programmed to set a ppm frequency accuracy of reference to feedback signals of the PLL for each event to occur. When a PLL digital lock event occurs the PLL's digital lock detect is asserted true. When the holdover exit event occurs, the device will exit holdover mode.

EVENT	PLL	WINDOW SIZE	LOCK COUNT
PLL1 Locked	PLL1	PLL1_WND_SIZE	PLL1_DLD_CNT
PLL2 Locked	PLL2	PLL2_WND_SIZE	PLL2_DLD_CNT
Holdover exit	PLL1	PLL1_WND_SIZE	HOLDOVER_DLD_CNT

For a digital lock detect event to occur there must be a "lock count" number of phase detector cycles of PLLX during which the time/phase error of the PLLX_R reference and PLLX_N feedback signal edges are within the user programmable "window size." Since there must be at least "lock count" phase detector events before a lock event occurs, a minimum digital lock event time can be calculated as "lock count" / f_{PDx} where X = 1 for PLL1 or 2 for PLL2.

By using [Equation 3](#), values for a "lock count" and "window size" can be chosen to set the frequency accuracy required by the system in ppm before the digital lock detect event occurs:

$$\text{ppm} = \frac{1e6 \times \text{PLLX_WND_SIZE} \times f_{PDx}}{\text{PLLX_DLD_CNT}} \quad (3)$$

The effect of the "lock count" value is that it shortens the effective lock window size by dividing the "window size" by "lock count".

If at any time the PLLX_R reference and PLLX_N feedback signals are outside the time window set by "window size", then the "lock count" value is reset to 0.

10.2.1.1 Minimum Lock Time Calculation Example

To calculate the minimum PLL2 digital lock time given a PLL2 phase detector frequency of 40 MHz and PLL2_DLD_CNT = 10,000. Then the minimum lock time of PLL2 will be 10,000 / 40 MHz = 250 μ s.

10.2.2 Driving CLKin AND OSCin Inputs

10.2.2.1 Driving CLKin PINS with a Differential Source

Both CLKin ports can be driven by differential signals. It is recommended that the input mode be set to bipolar (CLKinX_BUF_TYPE = 0) when using differential reference clocks. The LMK0482x family internally biases the input pins so the differential interface should be AC coupled. The recommended circuits for driving the CLKin pins with either LVDS or LVPECL are shown in [Figure 20](#) and [Figure 21](#).

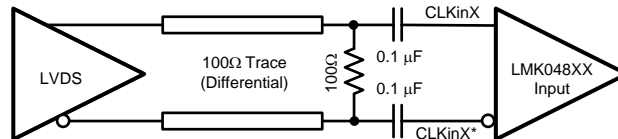

Figure 20. CLKinX/X* Termination for an LVDS Reference Clock Source

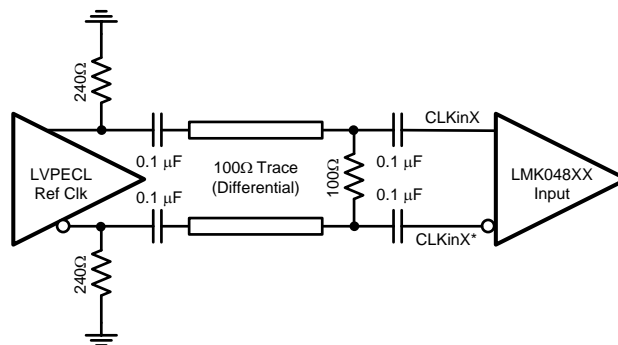

Figure 21. CLKinX/X* Termination for an LVPECL Reference Clock Source

Finally, a reference clock source that produces a differential sine wave output can drive the CLKin pins using the following circuit. Note: the signal level must conform to the requirements for the CLKin pins listed in [Electrical Characteristics](#).

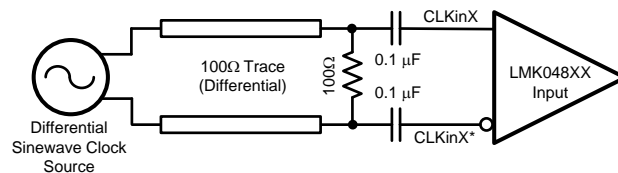

Figure 22. CLKinX/X* Termination for a Differential Sinewave Reference Clock Source

10.2.2.2 Driving CLKin Pins with a Single-ended Source

The CLKin pins of the LMK0482x family can be driven using a single-ended reference clock source, for example, either a sine wave source or an LVCMOS/LVTTL source. Either AC coupling or DC coupling may be used. In the case of the sine wave source that is expecting a 50 Ω load, it is recommended that AC coupling be used as shown in the circuit below with a 50- Ω termination.

NOTE

The signal level must conform to the requirements for the CLKin pins listed in [Electrical Characteristics](#). CLKinX_BUF_TYPE is recommended to be set to bipolar mode (CLKinX_BUF_TYPE = 0).

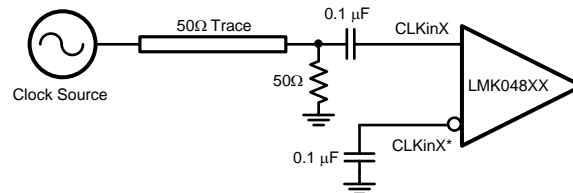

Figure 23. CLKinX/X* Single-ended Termination

If the CLKin pins are being driven with a single-ended LVCMOS/LVTTL source, either DC coupling or AC coupling may be used. If DC coupling is used, the CLKinX_BUF_TYPE should be set to MOS buffer mode (CLKinX_BUF_TYPE = 1) and the voltage swing of the source must meet the specifications for DC coupled, MOS-mode clock inputs given in [Electrical Characteristics](#). If AC coupling is used, the CLKinX_BUF_TYPE should be set to the bipolar buffer mode (CLKinX_BUF_TYPE = 0). The voltage swing at the input pins must meet the specifications for AC coupled, bipolar mode clock inputs given in [Electrical Characteristics](#). In this case, some attenuation of the clock input level may be required. A simple resistive divider circuit before the AC coupling capacitor is sufficient.

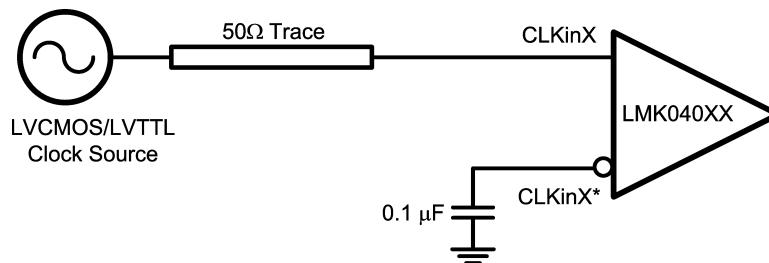

Figure 24. DC Coupled LVCMOS/LVTTL Reference Clock

10.2.3 Design Example

This design example below highlights using the available tools to design loop filters and create programming map for LMK0482x.

10.2.3.1 Design Requirements

Clocks outputs:

- 1x 245.76 MHz clock for JESD204B ADC, LVPECL.
 - This clock requires the best performance in this example.
- 2x 983.04 MHz clock for JESD204B DAC, LVPECL.
- 1x 122.88 MHz clock for JESD204B FPGA block, LVDS
- 3x 10.24 MHz SYSREF for ADC (LVPECL), DAC (LVPECL), FPGA (LVDS).
- 2x 122.88 MHz clock for FPGA, LVDS

For best performance, the highest possible phase detector frequency is used at PLL2. As such a 122.88 MHz VCXO is used.

10.2.3.2 Detailed Design Procedure

Please note this information is current as of the date of the release of this datasheet. Design tools receive continuous improvements to add features and improve model accuracy. Please refer to software instructions or training for latest features.

10.2.3.2.1 Device Selection

Enter the required frequencies into the tools. In this design the LMK04826B VCO0 and LMK04828B VCO1 both meet the design requirements. VCO0 offers lower noise floor while VCO1 offers improved VCO phase noise which reduces RMS jitter. Depending on application requirements and simulations one solution may be chosen over the other. In this case we will choose LMK04828B_VCO1 for improved RMS jitter in the 12 kHz to 20 MHz integration range. Larger integration ranges may benefit from the lower noise floor of VCO0.

10.2.3.2.1.1 Clock Architect

Only one device of a family will be returned as a possible solution. For the above example, LMK04828B_VCO1.

Under advanced tab, filtering of specific parts can be done using regular expressions in the Part Filter box. "LMK0482x.*" will filter for only LMK0482x devices (without quotes). More detailed filters can be given such as the entire part name LMK04826B_VCO0 to force an LMK04826B using VCO0 solution if one is available.

10.2.3.2.1.2 Clock Design Tool

In wizard-mode, select Dual Loop PLL to find LMK0482x devices. If a high frequency and clean reference is available, it is not required to use dual loop; PLL1 can be powered down and input is then provided via the OSCin port. When simulating single loop solutions, set PLL1 loop filter block to "0 Hz LBW" and use VCXO as the reference block.

10.2.3.2.2 Device Configuration and Simulation

The tools automatically configure the simulation to meet the input and output frequency requirements given and make assumptions about other parameters to give some default simulations. However the user may choose to make adjustments for more accurate simulations to their application. For example:

- Entering the VCO Gain of the external VCXO or possible external VCO used device.
- Adjust the charge pump current to help with loop filter component selection. Lower charge pump currents result in smaller components but may increase impacts of leakage and at the lowest values reduce PLL phase noise performance.
- Clock Design Tool allows loading a custom phase noise plot for any block. Typically, a custom phase noise plot is entered for CLKin to match the reference phase noise to device; a phase noise plot for the VCXO can additionally be provided to match the performance of VCXO used. For improved accuracy in simulation and optimum loop filter design, be sure to load these custom noise profiles for use in application.
- The design tools return with high reference/phase detector frequencies by default. In the Clock Design Tool the user may increase the reference divider to reduce the frequency if desired. Due to the narrow loop bandwidth used on PLL1, it is common to reduce the phase detector frequency on PLL1.

10.2.3.2.3 Device Programming

Using the clock design tools configuration the CodeLoader software is manually updated with this information to meet the required application. Note for the JESD204B outputs place device clocks on the DCLKoutX output, then turn on the paired SDCLKoutY output for SYSREF output. For Non-JESD204B outputs both DCLKoutX and paired SDCLKoutY may be driven by the device clock divider to maximize number of available outputs.

Frequency planning for assignment of outputs:

- To minimize crosstalk perform frequency planning / CLKout assignments to keep common frequencies on outputs close together.
- It is best to place common device clock output frequencies on outputs sharing the same Vcc group. For example, these outputs share Vcc4_CG2. Refer to [Pin Configuration and Functions](#) to see the Vcc groupings the clock outputs.

In this example, the 245.76 MHz ADC output needs the best performance. DCLKout2 on the LMK0482x provides the best noise floor / performance. The 245.76 MHz will be placed on DCLKout2 with 10.24 MHz SYSREF on SDCLKout3.

- For best performance the input and output drive level bits may be set. Best noise floor performance is achieved with DCLKout2_IDL = 1 and DCLKout2_ODL = 1.

In this example, the 983.04 MHz DAC output is placed on DCLKout4 and DCLKout6 with 10.24 MHz SYSREF on paired SDCLKout5 and SDCLKout7 outputs.

- These outputs share Vcc4_CG2.

In this example, the 122.88 MHz FPGA JESD204B output is placed on DCLKout10 with 10.24 MHz SYSREF on paired SDCLKout11 output.

Additionally, the 122.88 MHz FPGA non-JESD204B outputs are placed on DCLKout8 and SDCLKout9.

- When frequency planning, consider PLL2 as a clock output at the phase detector frequency. As such, these 122.88 MHz outputs have been placed on the outputs close to the PLL2 & Charge Pump power supplies.

Once the device programming is completed as desired in the CodeLoader software, it is possible to export the register settings from the Register tab for use in application.

10.2.3.3 Application Curves

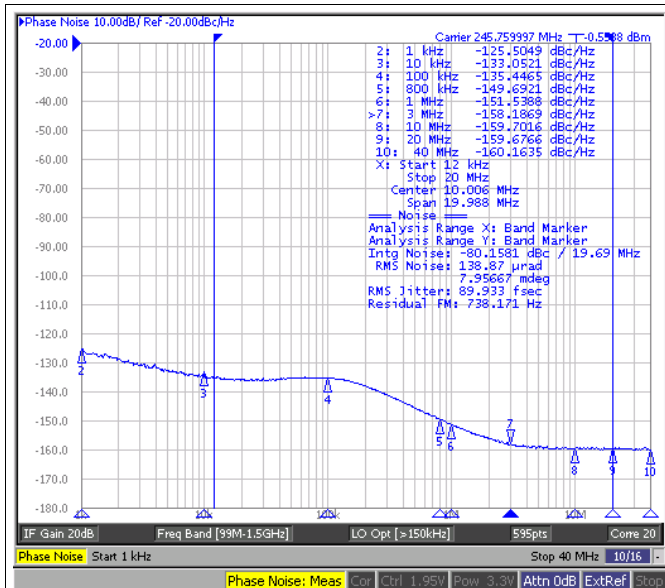

Figure 25. DCLKout0, 245.76 MHz
 LVPECL20 w/ 240 Ω emitter resistors
 DCLKout0_1_IDL = 1, DCLKout0_1_ODL = 1

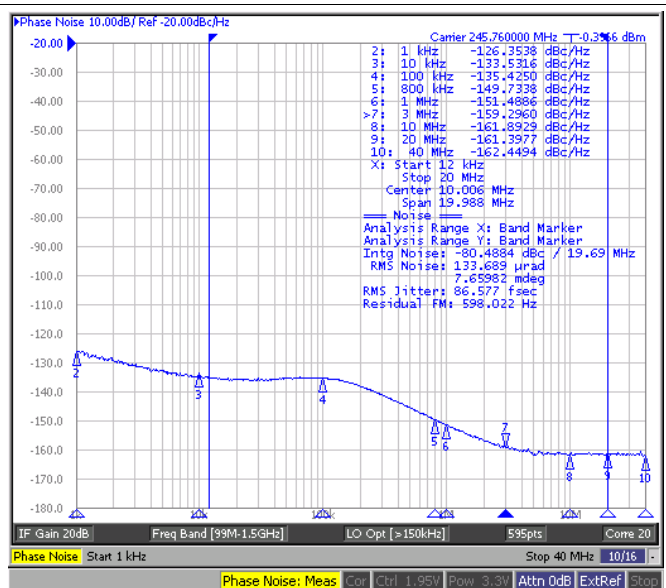

Figure 26. DCLKout2, 245.76 MHz
 LVPECL20 w/ 240 Ω emitter resistors
 DCLKout2_3_IDL = 1, DCLKout2_3_ODL = 1

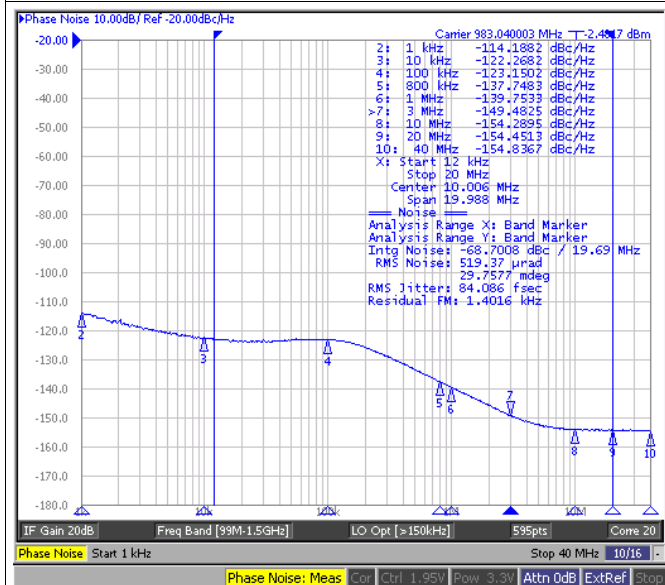

Figure 27. DCLKout4, 983.04 MHz
 LVPECL16 w/ 240 Ω emitter resistors
 DCLKout0_1_IDL = 1, DCLKout0_1_ODL = 0

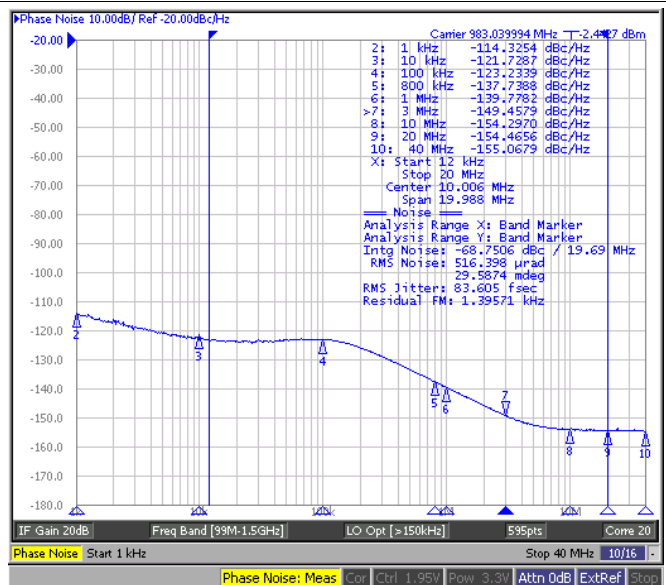

Figure 28. DCLKout6, 983.04 MHz
 LVPECL16 w/ 240 Ω emitter resistors
 DCLKout0_1_IDL = 1, DCLKout0_1_ODL = 0

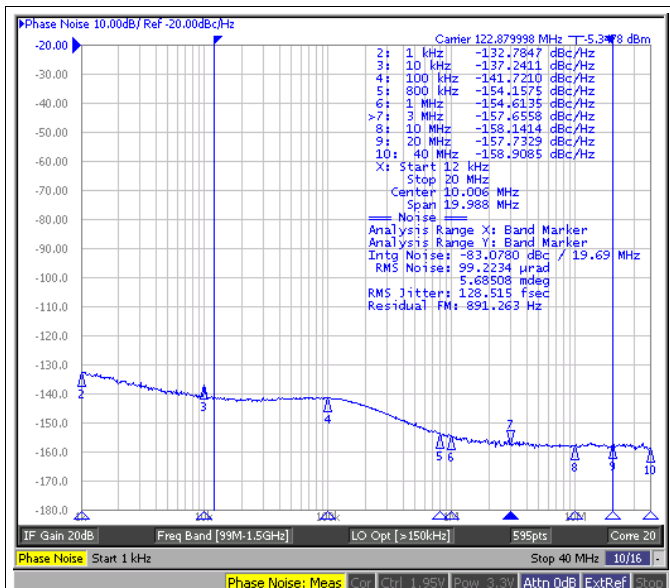

Figure 29. DCLKout10, 122.88 MHz, LVDS
 DCLKout0_1_IDL = 1, DCLKout0_1_ODL = 0

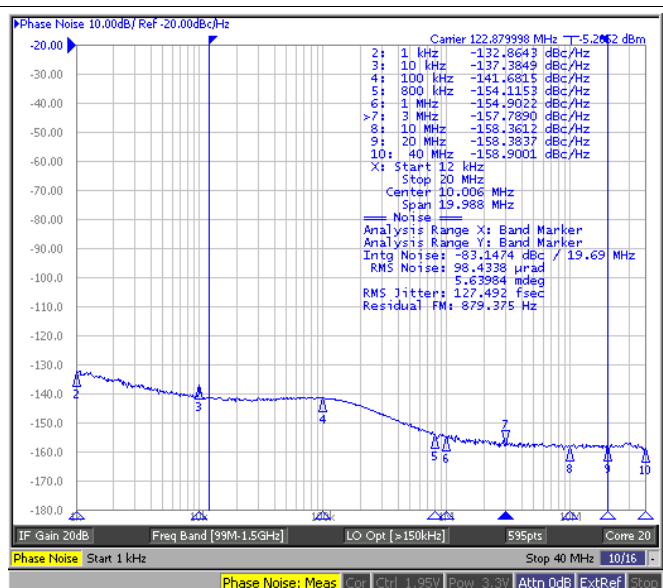

Figure 30. SDCLKout11, 122.88 MHz, LVDS
 DCLKout0_1_IDL = 1, DCLKout0_1_ODL = 0

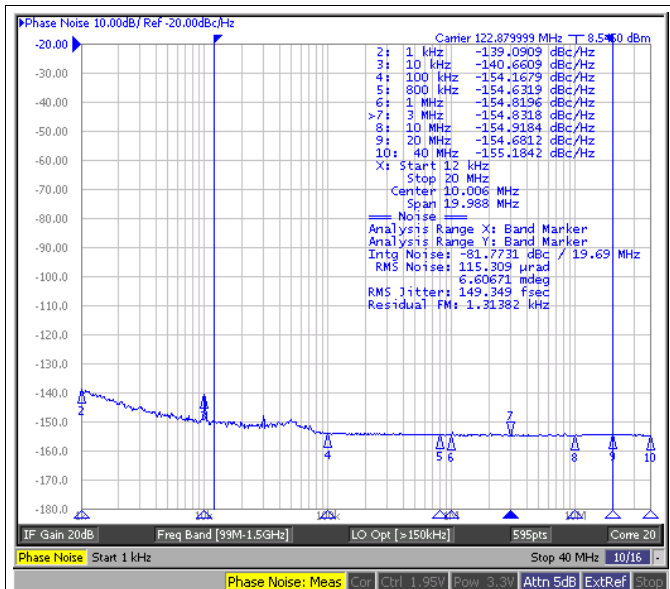

Figure 31. OSCout, 122.88 MHz, LVCMOS (Norm/Inv)
 Normal output measured, Inverse 50 Ω termination

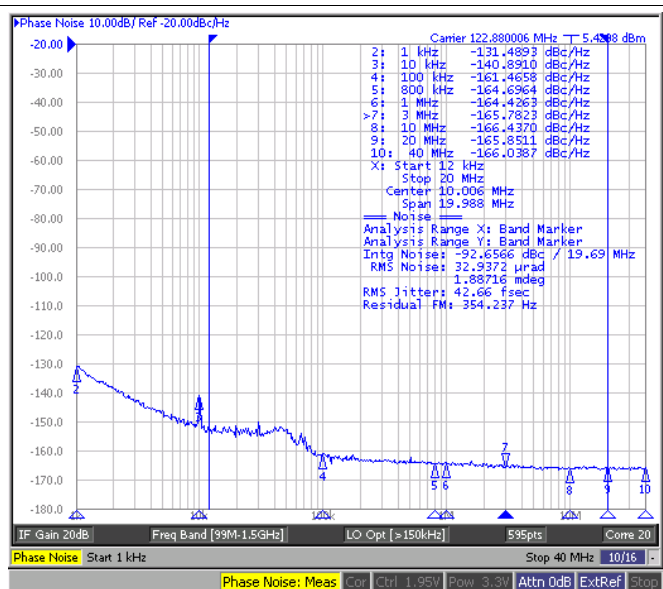

Figure 32. Direct VCXO Measurement
 Open loop, holdover mode set

10.3 Do's and Don'ts

10.3.1 Pin Connection Recommendations

- **V_{CC} Pins and Decoupling:** all V_{CC} pins must always be connected.
- **Unused Clock Outputs:** leave unused clock outputs floating and powered down.
- **Unused Clock Inputs:** unused clock inputs can be left floating.

11 Power Supply Recommendations

11.1 Current Consumption / Power Dissipation Calculations

From [Table 84](#) the current consumption can be calculated for any configuration. Data below is typical and not assured.

Table 84. Typical Current Consumption for Selected Functional Blocks
($T_A = 25\text{ }^\circ\text{C}$, $V_{CC} = 3.3\text{ V}$)

BLOCK	CONDITION		TYPICAL I_{CC} (mA)	POWER DISSIPATED in DEVICE (mW)	POWER DISSIPATED EXTERNALLY (mW)
CORE and FUNCTIONAL BLOCKS					
Core	Dual Loop, Internal VCO0	PLL1 and PLL2 locked	131.5	433.95	-
VCO (with VCO divider for LMK04821)	VCO1 is selected	LMK04826B/LMK04828 B	13.5	44.55	-
		LMK04821	22	72.6	-
OSCin Doubler	Doubler is enabled	EN_PLL2_REF_2X = 1	3	9.9	-
CLKin	Any one of the CLKinX is enabled		4.9	16.17	-
Holdover	Holdover is enabled	HOLDOVER_EN = 1	1.3	4.29	-
	Hitless switch is enabled	HOLDOVER_HITLESS_SWITCH = 1	0.9	2.97	-
	Track mode	TRACK_EN = 1	2.5	8.25	-
SYNC_EN = 1	Required for SYNC and SYSREF functionality		7.6	25.08	-
SYSREF	Enabled	SYSREF_PD = 0	27.2	89.76	-
	Dynamic Digital Delay enabled	SYSREF_DDLY_PD = 0	5	16.5	-
	Pulser is enabled	SYSREF_PLSR_PD = 0	4.1	13.53	-
	SYSREF Pulses mode	SYSREF_MUX = 2	3	9.9	-
	SYSREF Continuous mode	SYSREF_MUX = 3	3	9.9	-
CLOCK GROUP					
Enabled	Any one of the CLKoutX_Y_PD = 0		20.1	66.33	-
IDL	Any one of the CLKoutX_Y_IDL = 1		2.2	7.26	-
ODL	Any one of the CLKoutX_Y_ODL = 1		3.2	10.56	-
Clock Divider	Divider Only	DCLKoutX_MUX = 0	13.6	44.88	-
	Divider + DCC + HS	DCLKoutX_MUX = 1	17.7	58.41	-
	Analog Delay + Divider	DCLKoutX_MUX = 3	13.6	44.88	-
CLOCK OUTPUT BUFFERS					
LVDS	100 Ω differential termination		6	19.8	-
HSDS	HSDS 6 mA, 100 Ω differential termination		8.8	29.04	-
	HSDS 8 mA, 100 Ω differential termination		11.6	38.28	-
	HSDS 10 mA, 100 Ω differential termination		19.4	64.02	-
OSCOut BUFFERS					
LVDS	100 Ω differential termination		18.5	61.05	-
LVCMOS	LVCMOS Pair	150 MHz	42.6	140.58	-
	LVCMOS Single	150 MHz	27	89.1	-

12 Layout

12.1 Layout Guidelines

12.1.1 Thermal Management

Power consumption of the LMK0482x family of devices can be high enough to require attention to thermal management. For reliability and performance reasons the die temperature should be limited to a maximum of 125°C. That is, as an estimate, T_A (ambient temperature) plus device power consumption times $R_{\theta JA}$ should not exceed 125°C.

The package of the device has an exposed pad that provides the primary heat removal path as well as excellent electrical grounding to a printed circuit board. To maximize the removal of heat from the package a thermal land pattern including multiple vias to a ground plane must be incorporated on the PCB within the footprint of the package. The exposed pad must be soldered down to ensure adequate heat conduction out of the package.

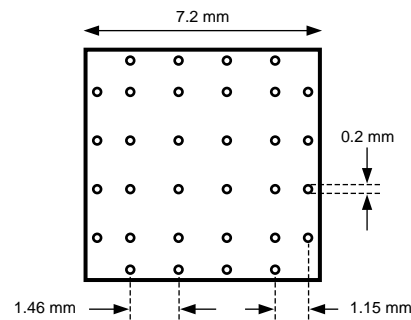
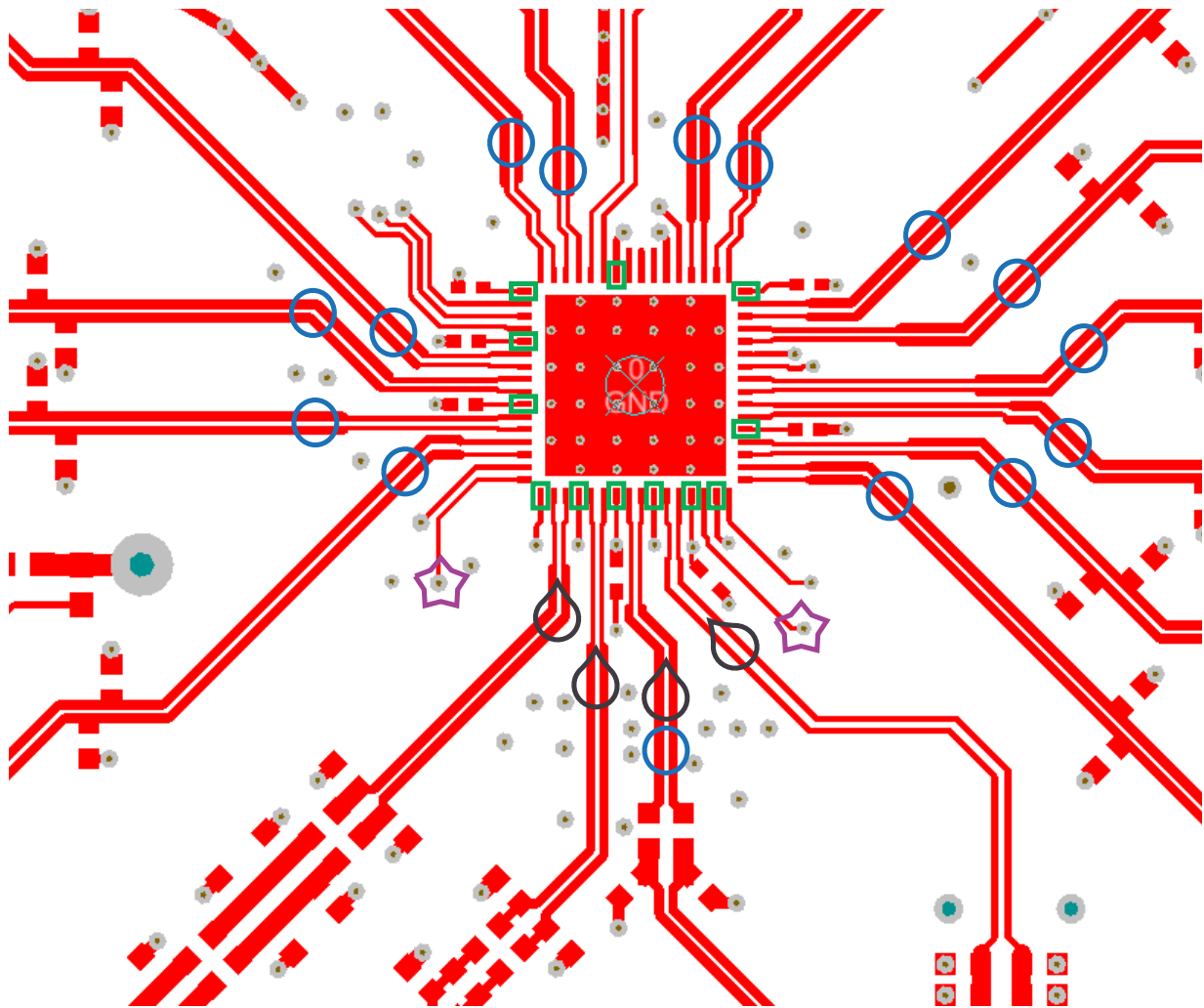

Figure 33. Recommended Land and Via Pattern

12.2 Layout Example



CLKin and OSCin path – if differential input (preferred) route traces tightly coupled. If single ended, have at least 3 trace width (of CLKin/OSCin trace) separation from other RF traces. When using CLKin1 for high frequency input for external VCO or distribution, a 3 dB pi pad is suggested for termination. Place terminations close to IC. CLKin2 and OSCout share pins and is programmable for input or output.



For CLKout Vccs in JESD204B application, place ferrite beads then 1 μ F capacitor. The 1 μ F capacitor supports low frequency SYSREF switching/turn on. For CLKout Vccs in traditional application place ferrite bead on top layer close to pins to choke high frequency noise from via.



Charge pump output – shorter traces are better. Place resistors and caps closer to IC except for a single cap and associated resistor, if any, next to VCXO. In a 2nd order filter place C1 close to VCXO Vtune pin. In a 3rd and 4th order filter place R3/C3 or R4/C4 respectively close to VCXO.



CLKouts/OSCouts – Normally differential signals, should be routed tightly coupled to minimize PCB crosstalk. Trace impedance and terminations should be designed according to output type being used (i.e. LVDS, LVPECL, LVCMC). For LVPECL/LCPECL place emitter resistors close to IC. OSCout shares pins with CLKin2 and is programmable input or output.

Figure 34. LMK0482x Layout Example

13 Device and Documentation Support

13.1 Device Support

13.1.1 Development Support

13.1.1.1 Clock Architect

Part selection, loop filter design, simulation.

For the Clock Architect, go to www.ti.com/clockarchitect.

13.1.1.2 Clock Design Tool

Limited part selection, advanced loop filter design and simulation capabilities.

For the Clock Design Tool, go to www.ti.com/tool/clockdesigntool. Please note training videos on this tool page.

13.1.1.3 CodeLoader

EVM programming software. Can also be used to generate register map for programming for a specific application.

For CodeLoader, go to www.ti.com/tool/codeloader

13.2 Related Links

The table below lists quick access links. Categories include technical documents, support and community resources, tools and software, and quick access to sample or buy.

Table 85. Related Links

PARTS	PRODUCT FOLDER	SAMPLE & BUY	TECHNICAL DOCUMENTS	TOOLS & SOFTWARE	SUPPORT & COMMUNITY
LMK04821	Click here	Click here	Click here	Click here	Click here
LMK04826	Click here	Click here	Click here	Click here	Click here
LMK04828	Click here	Click here	Click here	Click here	Click here

13.3 Trademarks

PLLatinum is a trademark of Texas Instruments.

All other trademarks are the property of their respective owners.

13.4 Electrostatic Discharge Caution



These devices have limited built-in ESD protection. The leads should be shorted together or the device placed in conductive foam during storage or handling to prevent electrostatic damage to the MOS gates.

13.5 Glossary

SLYZ022 — *TI Glossary*.

This glossary lists and explains terms, acronyms, and definitions.

14 Mechanical, Packaging, and Orderable Information

The following pages include mechanical, packaging, and orderable information. This information is the most current data available for the designated devices. This data is subject to change without notice and revision of this document. For browser-based versions of this data sheet, refer to the left-hand navigation.

PACKAGING INFORMATION

Orderable Device	Status (1)	Package Type	Package Drawing	Pins	Package Qty	Eco Plan (2)	Lead/Ball Finish (6)	MSL Peak Temp (3)	Op Temp (°C)	Device Marking (4/5)	Samples
LMK04821NKDR	ACTIVE	WQFN	NKD	64	1000	Green (RoHS & no Sb/Br)	CU SN	Level-3-260C-168 HR	-40 to 85	K04821NKD	Samples
LMK04821NKDT	ACTIVE	WQFN	NKD	64	250	Green (RoHS & no Sb/Br)	CU SN	Level-3-260C-168 HR	-40 to 85	K04821NKD	Samples
LMK04826BISQ/NOPB	ACTIVE	WQFN	NKD	64	1000	Green (RoHS & no Sb/Br)	CU SN	Level-3-260C-168 HR	-40 to 85	K04826BISQ	Samples
LMK04826BISQE/NOPB	ACTIVE	WQFN	NKD	64	250	Green (RoHS & no Sb/Br)	CU SN	Level-3-260C-168 HR	-40 to 85	K04826BISQ	Samples
LMK04826BISQX/NOPB	ACTIVE	WQFN	NKD	64	2000	Green (RoHS & no Sb/Br)	CU SN	Level-3-260C-168 HR	-40 to 85	K04826BISQ	Samples
LMK04828BISQ/NOPB	ACTIVE	WQFN	NKD	64	1000	Green (RoHS & no Sb/Br)	CU SN	Level-3-260C-168 HR	-40 to 85	K04828BISQ	Samples
LMK04828BISQE/NOPB	ACTIVE	WQFN	NKD	64	250	Green (RoHS & no Sb/Br)	CU SN	Level-3-260C-168 HR	-40 to 85	K04828BISQ	Samples
LMK04828BISQX/NOPB	ACTIVE	WQFN	NKD	64	2000	Green (RoHS & no Sb/Br)	CU SN	Level-3-260C-168 HR	-40 to 85	K04828BISQ	Samples

(1) The marketing status values are defined as follows:

ACTIVE: Product device recommended for new designs.

LIFEBUY: TI has announced that the device will be discontinued, and a lifetime-buy period is in effect.

NRND: Not recommended for new designs. Device is in production to support existing customers, but TI does not recommend using this part in a new design.

PREVIEW: Device has been announced but is not in production. Samples may or may not be available.

OBSELETE: TI has discontinued the production of the device.

(2) Eco Plan - The planned eco-friendly classification: Pb-Free (RoHS), Pb-Free (RoHS Exempt), or Green (RoHS & no Sb/Br) - please check <http://www.ti.com/productcontent> for the latest availability information and additional product content details.

TBD: The Pb-Free/Green conversion plan has not been defined.

Pb-Free (RoHS): TI's terms "Lead-Free" or "Pb-Free" mean semiconductor products that are compatible with the current RoHS requirements for all 6 substances, including the requirement that lead not exceed 0.1% by weight in homogeneous materials. Where designed to be soldered at high temperatures, TI Pb-Free products are suitable for use in specified lead-free processes.

Pb-Free (RoHS Exempt): This component has a RoHS exemption for either 1) lead-based flip-chip solder bumps used between the die and package, or 2) lead-based die adhesive used between the die and leadframe. The component is otherwise considered Pb-Free (RoHS compatible) as defined above.

Green (RoHS & no Sb/Br): TI defines "Green" to mean Pb-Free (RoHS compatible), and free of Bromine (Br) and Antimony (Sb) based flame retardants (Br or Sb do not exceed 0.1% by weight in homogeneous material)

(3) MSL, Peak Temp. - The Moisture Sensitivity Level rating according to the JEDEC industry standard classifications, and peak solder temperature.

(4) There may be additional marking, which relates to the logo, the lot trace code information, or the environmental category on the device.

(5) Multiple Device Markings will be inside parentheses. Only one Device Marking contained in parentheses and separated by a "~" will appear on a device. If a line is indented then it is a continuation of the previous line and the two combined represent the entire Device Marking for that device.

(6) Lead/Ball Finish - Orderable Devices may have multiple material finish options. Finish options are separated by a vertical ruled line. Lead/Ball Finish values may wrap to two lines if the finish value exceeds the maximum column width.

Important Information and Disclaimer:The information provided on this page represents TI's knowledge and belief as of the date that it is provided. TI bases its knowledge and belief on information provided by third parties, and makes no representation or warranty as to the accuracy of such information. Efforts are underway to better integrate information from third parties. TI has taken and continues to take reasonable steps to provide representative and accurate information but may not have conducted destructive testing or chemical analysis on incoming materials and chemicals. TI and TI suppliers consider certain information to be proprietary, and thus CAS numbers and other limited information may not be available for release.

In no event shall TI's liability arising out of such information exceed the total purchase price of the TI part(s) at issue in this document sold by TI to Customer on an annual basis.

TAPE AND REEL INFORMATION

QUADRANT ASSIGNMENTS FOR PIN 1 ORIENTATION IN TAPE

*All dimensions are nominal

Device	Package Type	Package Drawing	Pins	SPQ	Reel Diameter (mm)	Reel Width W1 (mm)	A0 (mm)	B0 (mm)	K0 (mm)	P1 (mm)	W (mm)	Pin1 Quadrant
LMK04821NKDR	WQFN	NKD	64	1000	330.0	16.4	9.3	9.3	1.3	12.0	16.0	Q1
LMK04821NKDT	WQFN	NKD	64	250	178.0	16.4	9.3	9.3	1.3	12.0	16.0	Q1
LMK04826BISQ/NOPB	WQFN	NKD	64	1000	330.0	16.4	9.3	9.3	1.3	12.0	16.0	Q1
LMK04826BISQE/NOPB	WQFN	NKD	64	250	178.0	16.4	9.3	9.3	1.3	12.0	16.0	Q1
LMK04826BISQX/NOPB	WQFN	NKD	64	2000	330.0	16.4	9.3	9.3	1.3	12.0	16.0	Q1
LMK04828BISQ/NOPB	WQFN	NKD	64	1000	330.0	16.4	9.3	9.3	1.3	12.0	16.0	Q1

TAPE AND REEL BOX DIMENSIONS

*All dimensions are nominal

Device	Package Type	Package Drawing	Pins	SPQ	Length (mm)	Width (mm)	Height (mm)
LMK04821NKDR	WQFN	NKD	64	1000	367.0	367.0	38.0
LMK04821NKDT	WQFN	NKD	64	250	210.0	185.0	35.0
LMK04826BISQ/NOPB	WQFN	NKD	64	1000	367.0	367.0	38.0
LMK04826BISQE/NOPB	WQFN	NKD	64	250	210.0	185.0	35.0
LMK04826BISQX/NOPB	WQFN	NKD	64	2000	367.0	367.0	38.0
LMK04828BISQ/NOPB	WQFN	NKD	64	1000	367.0	367.0	38.0

PACKAGE OUTLINE

NKD0064A

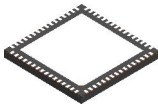

WQFN - 0.8 mm max height

WQFN

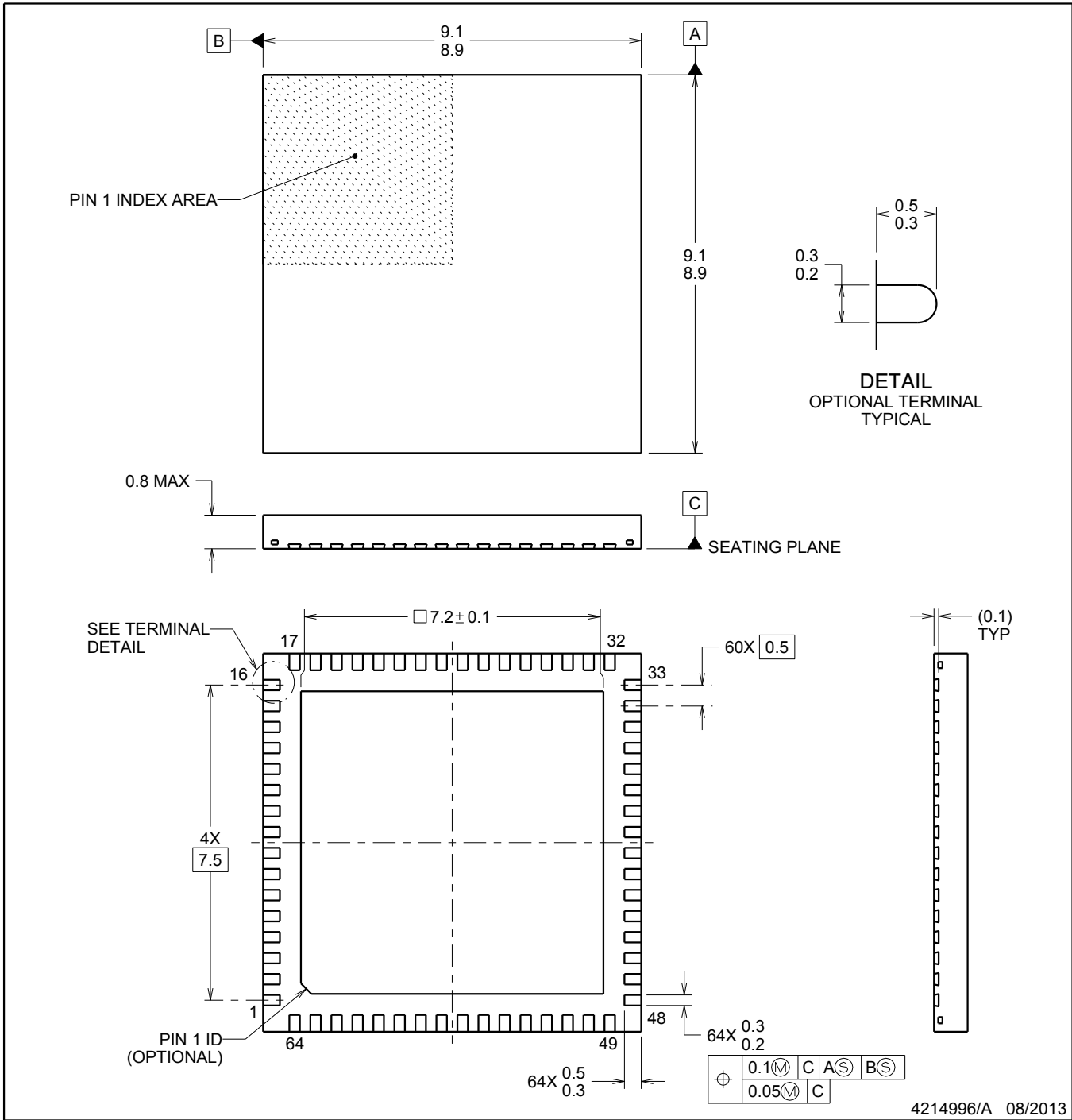

NOTES:

1. All linear dimensions are in millimeters. Dimensions in parenthesis are for reference only. Dimensioning and tolerancing per ASME Y14.5M.
2. This drawing is subject to change without notice.
3. The package thermal pad must be soldered to the printed circuit board for thermal and mechanical performance.

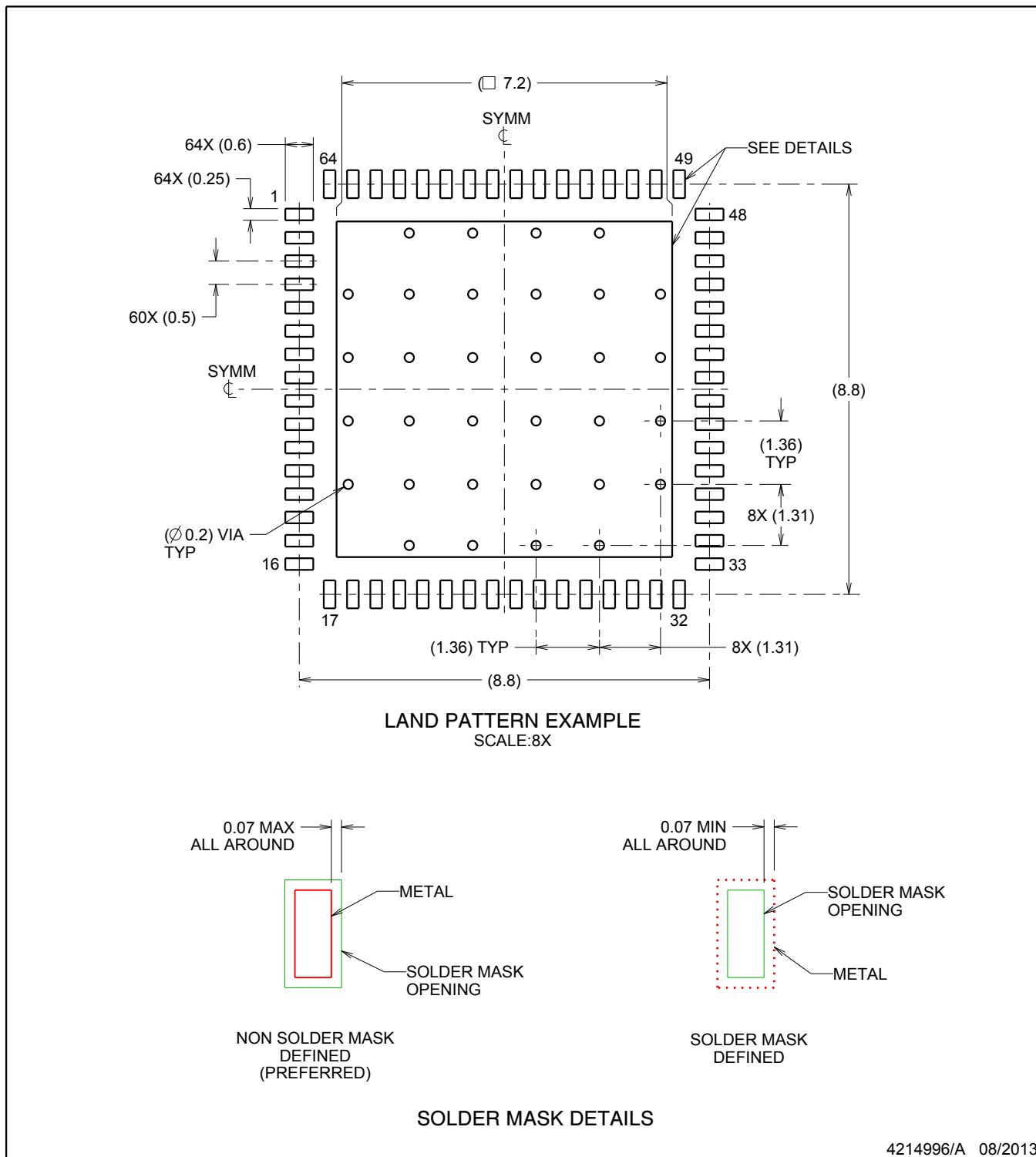

NOTES: (continued)

4. This package is designed to be soldered to a thermal pad on the board. For more information, refer to QFN/SON PCB application note in literature No. SLUA271 (www.ti.com/lit/sluea271).

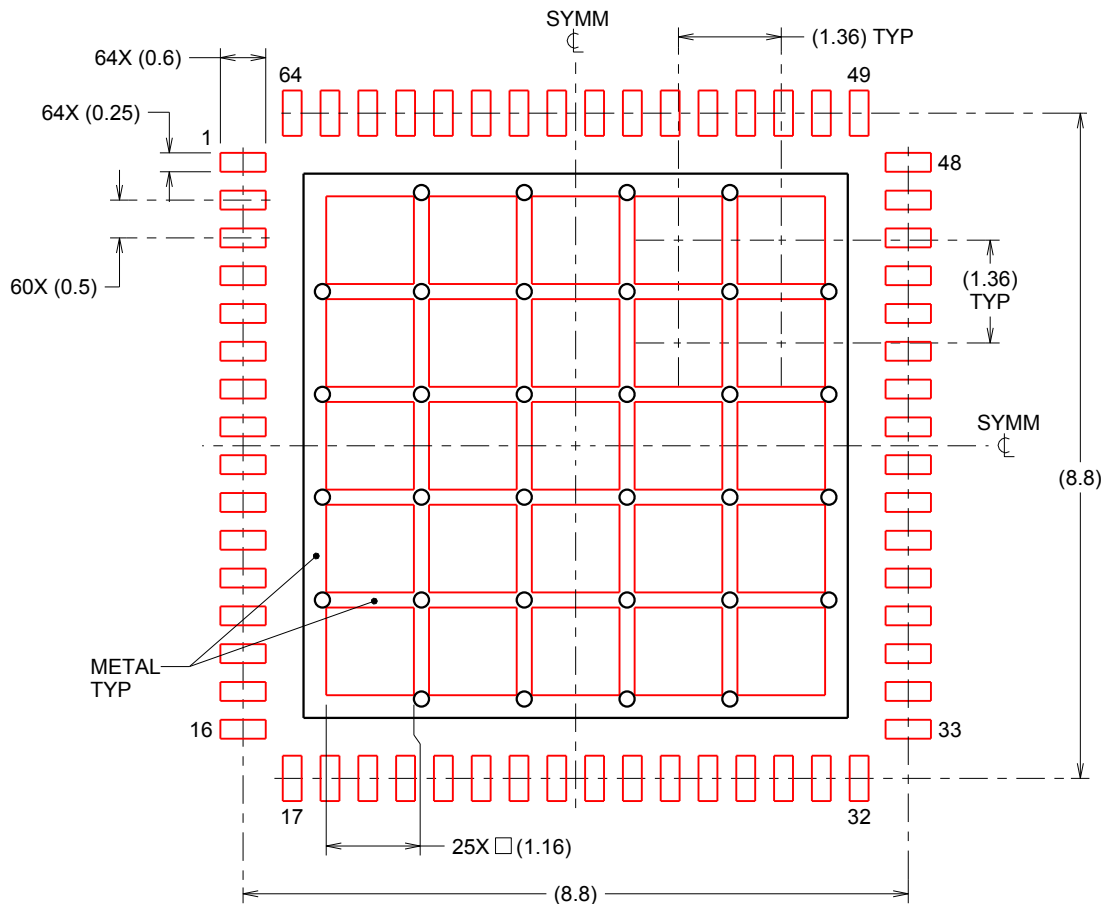

SOLDERPASTE EXAMPLE
 BASED ON 0.125mm THICK STENCIL
 EXPOSED PAD
 65% PRINTED SOLDER COVERAGE BY AREA
 SCALE:10X

4214996/A 08/2013

NOTES: (continued)

5. Laser cutting apertures with trapezoidal walls and rounded corners may offer better paste release. IPC-7525 may have alternate design recommendations.

IMPORTANT NOTICE

Texas Instruments Incorporated (TI) reserves the right to make corrections, enhancements, improvements and other changes to its semiconductor products and services per JESD46, latest issue, and to discontinue any product or service per JESD48, latest issue. Buyers should obtain the latest relevant information before placing orders and should verify that such information is current and complete.

TI's published terms of sale for semiconductor products (<http://www.ti.com/sc/docs/stdterms.htm>) apply to the sale of packaged integrated circuit products that TI has qualified and released to market. Additional terms may apply to the use or sale of other types of TI products and services.

Reproduction of significant portions of TI information in TI data sheets is permissible only if reproduction is without alteration and is accompanied by all associated warranties, conditions, limitations, and notices. TI is not responsible or liable for such reproduced documentation. Information of third parties may be subject to additional restrictions. Resale of TI products or services with statements different from or beyond the parameters stated by TI for that product or service voids all express and any implied warranties for the associated TI product or service and is an unfair and deceptive business practice. TI is not responsible or liable for any such statements.

Buyers and others who are developing systems that incorporate TI products (collectively, "Designers") understand and agree that Designers remain responsible for using their independent analysis, evaluation and judgment in designing their applications and that Designers have full and exclusive responsibility to assure the safety of Designers' applications and compliance of their applications (and of all TI products used in or for Designers' applications) with all applicable regulations, laws and other applicable requirements. Designer represents that, with respect to their applications, Designer has all the necessary expertise to create and implement safeguards that (1) anticipate dangerous consequences of failures, (2) monitor failures and their consequences, and (3) lessen the likelihood of failures that might cause harm and take appropriate actions. Designer agrees that prior to using or distributing any applications that include TI products, Designer will thoroughly test such applications and the functionality of such TI products as used in such applications.

TI's provision of technical, application or other design advice, quality characterization, reliability data or other services or information, including, but not limited to, reference designs and materials relating to evaluation modules, (collectively, "TI Resources") are intended to assist designers who are developing applications that incorporate TI products; by downloading, accessing or using TI Resources in any way, Designer (individually or, if Designer is acting on behalf of a company, Designer's company) agrees to use any particular TI Resource solely for this purpose and subject to the terms of this Notice.

TI's provision of TI Resources does not expand or otherwise alter TI's applicable published warranties or warranty disclaimers for TI products, and no additional obligations or liabilities arise from TI providing such TI Resources. TI reserves the right to make corrections, enhancements, improvements and other changes to its TI Resources. TI has not conducted any testing other than that specifically described in the published documentation for a particular TI Resource.

Designer is authorized to use, copy and modify any individual TI Resource only in connection with the development of applications that include the TI product(s) identified in such TI Resource. NO OTHER LICENSE, EXPRESS OR IMPLIED, BY ESTOPPEL OR OTHERWISE TO ANY OTHER TI INTELLECTUAL PROPERTY RIGHT, AND NO LICENSE TO ANY TECHNOLOGY OR INTELLECTUAL PROPERTY RIGHT OF TI OR ANY THIRD PARTY IS GRANTED HEREIN, including but not limited to any patent right, copyright, mask work right, or other intellectual property right relating to any combination, machine, or process in which TI products or services are used. Information regarding or referencing third-party products or services does not constitute a license to use such products or services, or a warranty or endorsement thereof. Use of TI Resources may require a license from a third party under the patents or other intellectual property of the third party, or a license from TI under the patents or other intellectual property of TI.

TI RESOURCES ARE PROVIDED "AS IS" AND WITH ALL FAULTS. TI DISCLAIMS ALL OTHER WARRANTIES OR REPRESENTATIONS, EXPRESS OR IMPLIED, REGARDING RESOURCES OR USE THEREOF, INCLUDING BUT NOT LIMITED TO ACCURACY OR COMPLETENESS, TITLE, ANY EPIDEMIC FAILURE WARRANTY AND ANY IMPLIED WARRANTIES OF MERCHANTABILITY, FITNESS FOR A PARTICULAR PURPOSE, AND NON-INFRINGEMENT OF ANY THIRD PARTY INTELLECTUAL PROPERTY RIGHTS. TI SHALL NOT BE LIABLE FOR AND SHALL NOT DEFEND OR INDEMNIFY DESIGNER AGAINST ANY CLAIM, INCLUDING BUT NOT LIMITED TO ANY INFRINGEMENT CLAIM THAT RELATES TO OR IS BASED ON ANY COMBINATION OF PRODUCTS EVEN IF DESCRIBED IN TI RESOURCES OR OTHERWISE. IN NO EVENT SHALL TI BE LIABLE FOR ANY ACTUAL, DIRECT, SPECIAL, COLLATERAL, INDIRECT, PUNITIVE, INCIDENTAL, CONSEQUENTIAL OR EXEMPLARY DAMAGES IN CONNECTION WITH OR ARISING OUT OF TI RESOURCES OR USE THEREOF, AND REGARDLESS OF WHETHER TI HAS BEEN ADVISED OF THE POSSIBILITY OF SUCH DAMAGES.

Unless TI has explicitly designated an individual product as meeting the requirements of a particular industry standard (e.g., ISO/TS 16949 and ISO 26262), TI is not responsible for any failure to meet such industry standard requirements.

Where TI specifically promotes products as facilitating functional safety or as compliant with industry functional safety standards, such products are intended to help enable customers to design and create their own applications that meet applicable functional safety standards and requirements. Using products in an application does not by itself establish any safety features in the application. Designers must ensure compliance with safety-related requirements and standards applicable to their applications. Designer may not use any TI products in life-critical medical equipment unless authorized officers of the parties have executed a special contract specifically governing such use. Life-critical medical equipment is medical equipment where failure of such equipment would cause serious bodily injury or death (e.g., life support, pacemakers, defibrillators, heart pumps, neurostimulators, and implantables). Such equipment includes, without limitation, all medical devices identified by the U.S. Food and Drug Administration as Class III devices and equivalent classifications outside the U.S.

TI may expressly designate certain products as completing a particular qualification (e.g., Q100, Military Grade, or Enhanced Product). Designers agree that it has the necessary expertise to select the product with the appropriate qualification designation for their applications and that proper product selection is at Designers' own risk. Designers are solely responsible for compliance with all legal and regulatory requirements in connection with such selection.

Designer will fully indemnify TI and its representatives against any damages, costs, losses, and/or liabilities arising out of Designer's non-compliance with the terms and provisions of this Notice.