

Silicon Bridge Rectifiers

DB104S - DB107S

Features

- Glass passivated junction
- High surge current capability
- Saves space on printed circuit boards
- High-temp soldering guaranteed: 260°C @ 10s.
- RoHS compliant with Halogen-free



Mechanical Data

- Case: DFS molded plastic
- Molding compound meets UL 94 V-0 flammability rating
- Terminals: Lead Free Plating (Matte Tin Finish.)
- Polarity indicator: As marked on body

Maximum Ratings (@ T_A = 25°C unless otherwise specified)

Parameter	Symbol	DB104S	DB105S	DB106S	DB107S	Unit
Peak Repetitive Reverse Voltage	V _{RRM}	400	600	800	1000	V
RMS Reverse Voltage	V _{RMS}	280	420	560	700	V
DC Blocking Voltage	V _{DC}	400	400	800	1000	V
Maximum Average Forward Output Current	I _{F_AV}	1.0				A
Peak Forward Surge Current, 8.3ms Single Half Sine wave	I _{FSM}	30				A
I ² t Rating for fusing	I ² t	3.7				A ² s

Thermal Characteristics

Parameter	Symbol	DB104S	DB105S	DB106S	DB107S	Unit
Typical Thermal Resistance per leg *1	R _{θJA}	66				°C/W
	R _{θJC}	30				
	R _{θJL}	28				
Operating Junction Temperature Range	T _J	-55 ~ +150				°C
Storage Temperature Range	T _{STG}	-55 ~ +150				°C

Note *1: Device mounted on p.c.b. with 10 mm x 20 mm x 0.1mm copper pad area

Silicon Bridge Rectifiers

DB104S - DB107S

Electrical Characteristics (@ $T_A = 25^\circ\text{C}$ unless otherwise specified)

Parameter	Symbol	Test Condition	Typ.	Max.	Unit	
Maximum Instantaneous Forward Voltage	V_F	$I_F = 1.0\text{A}$ Per Diode	-	1.1	V	
Maximum Reverse Current	I_R	Rated V_R , Per Diode	@ $T_A = 25^\circ\text{C}$	-	10	μA
			@ $T_A = 100^\circ\text{C}$	-	1000	

Silicon Bridge Rectifiers

DB104S - DB107S

Ratings and Characteristic Curves (@ $T_A=25^\circ\text{C}$ unless otherwise noted)

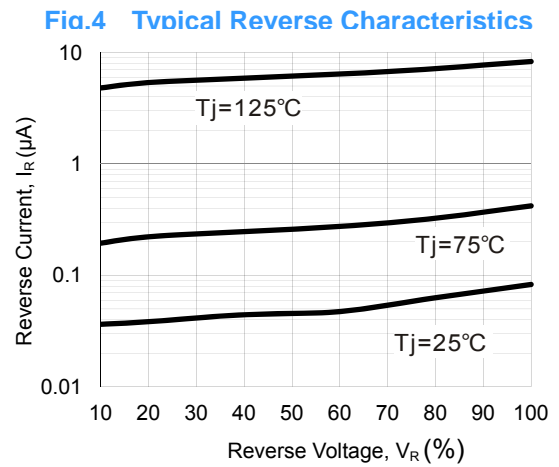
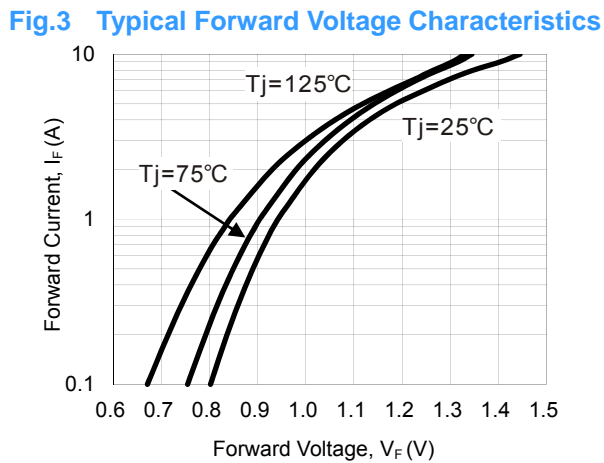
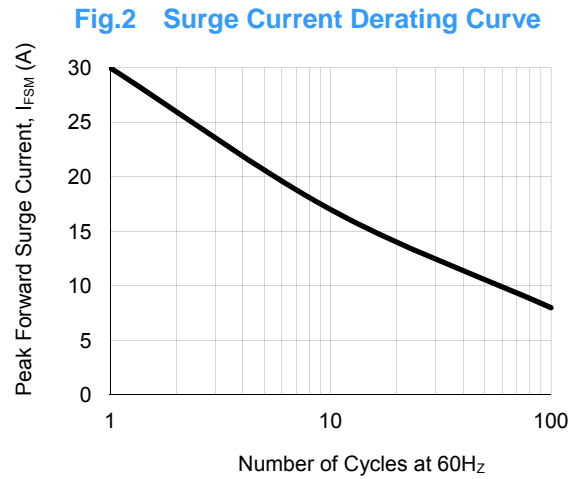
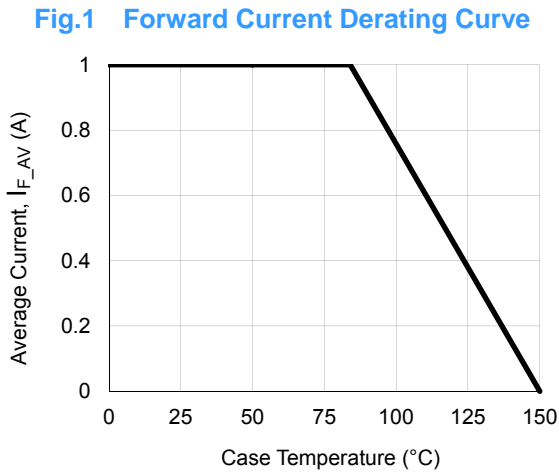

Silicon Bridge Rectifiers

DB104S - DB107S

Package Outline Dimensions (Unit: mm)

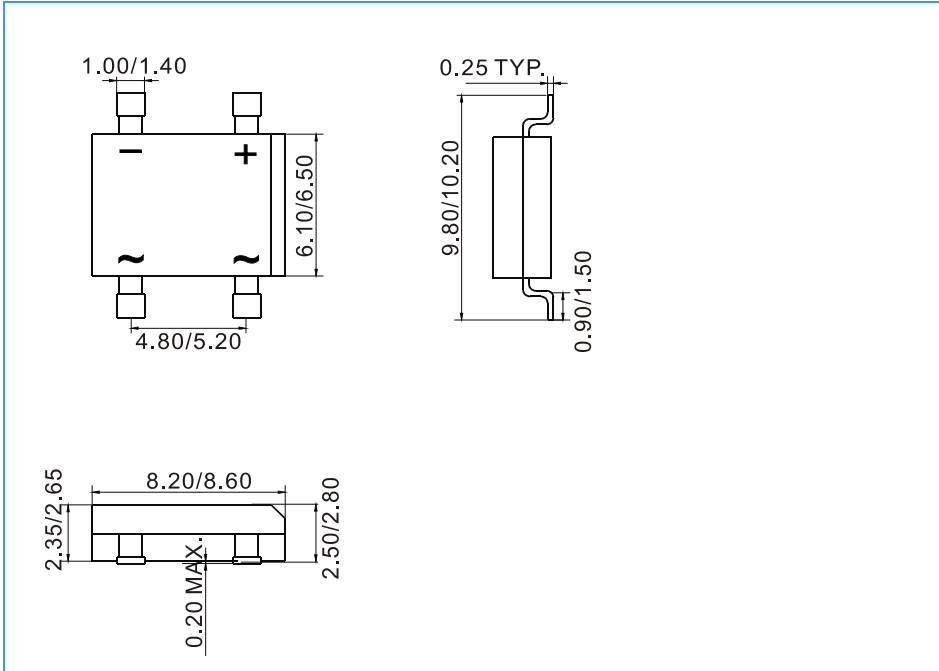

Mounting Pad Layout (Unit: mm)

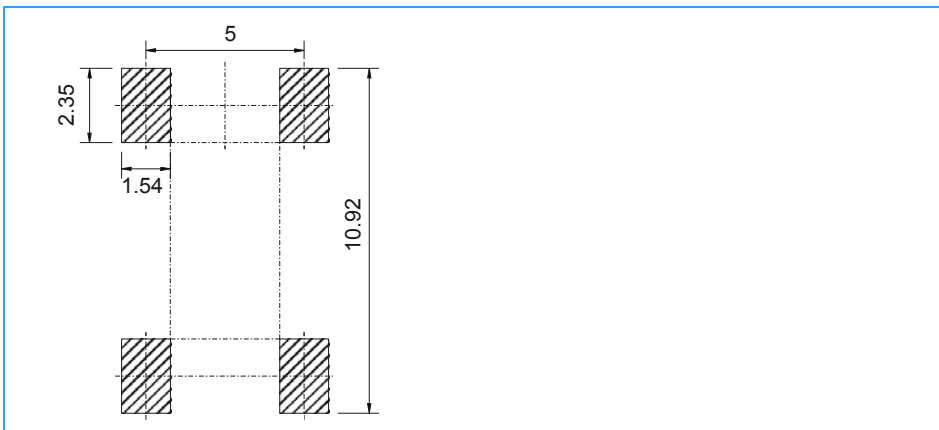

Ordering Information

Part Number	Marking	Package	Shipping Quantity
DB104S	DB104S	DFS	1500 / Tape & Reel
DB105S	DB105S	DFS	1500 / Tape & Reel
DB106S	DB106S	DFS	1500 / Tape & Reel
DB107S	DB107S	DFS	1500 / Tape & Reel