

未注公差/General tolerances (mm)													0.1/10
0	>3	>6	>10	>18	>30	>50	>80	>120	>180	>250	>315	>400	
3	6	10	18	30	50	80	120	180	250	315	400	500	>500
±0.12	±0.18	±0.22	±0.26	±0.31	±0.37	±0.57	±0.80	±0.93	±1.05	±1.15	±1.60	±2.20	±2.50

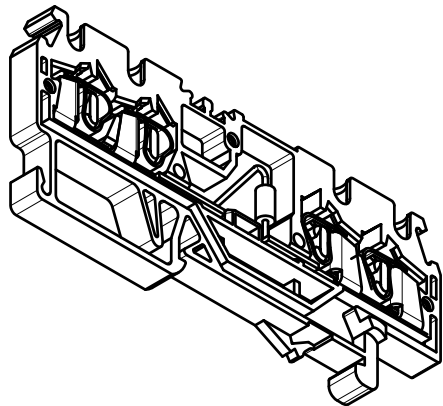
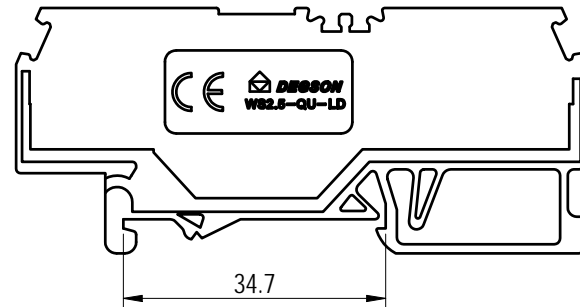
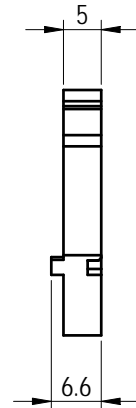
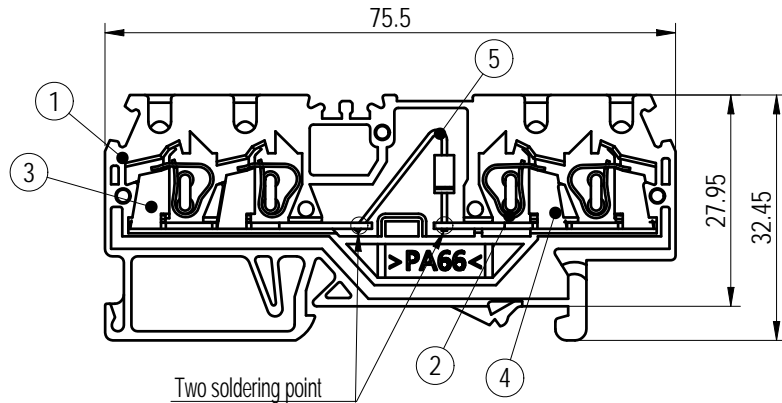
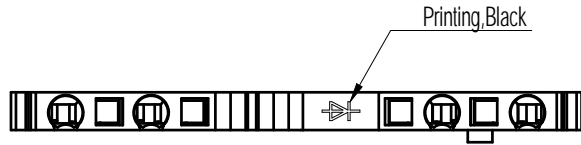

ITEM	NAME OF PART	MATERIAL	NOTES
5	Diode	/	1N4007
4	Current carrier 2	Copper	Sn plated
3	Current carrier 1	Copper	Sn plated
2	Spring	Stainless steel	/
1	Housing	PA66	UL94V-0

UL 标准/UL Standard:	B	C	D
额定电压/电流/Rated Voltage(V)/Current(A)	/	/	/
IEC 标准/IEC Standard:			
过压类别/Overvoltage Category/污染等级/Pollution Degree	III/3	III/2	II/2
额定电压/电流/Rated Voltage(V)/Current(A)	250/0.5	/	/
最大逆向耐压/Reverse Voltage(KV)	1	/	/
线径范围(硬线和软线)/Wire Range(rigid and flexible)(AWG/mm²)	28~14/ 0.2~2.5		
间距/Pitch(mm)/线数范围/Poles	5.0/01P		
剥线长度/Stripping length(mm)	9		
使用温度范围/Operating temperature(°C)	-40~+105		
符合RoHS环保要求/Conform to RoHS	Yes		

DEGSON		MATERIAL:	SURFACE/COLOR:		
MAT NO./REV: 11030000797-1 / 00		MAT STATUS: 批量			
APPD: Peng M	2022.12.10	NAME			
CHKD: Gao WG	2022.12.10	WS2.5-QU-LD-L-R-01P-11-00Z(H)			
DRFT: Xie XD	2022.12.10	DRAWING NO.	TYPE	DRAWING STATUS	SCALE
A4		200110775	CUSTOMER DRAWING	work	1:1
					SHEET 1/1

REV	ECN	DESCRIPTION	DRFT	DATE
00		New Product	Xie XD	2022.12.10

Transfer or duplication of this document as well as the utilization or communication of its contents are prohibited unless approval is granted. Weights, for comparison, III rights reserved for patent. 任何复制或传播此文件以及其内容的使用或沟通均须经批准。重量, 为比较, III 权利保留。如有专利, 其权利保留。如有专利, 其权利保留。