

未注公差/General tolerances (mm)													0.1/10
0	>3	>6	>10	>18	>30	>50	>80	>120	>180	>250	>315	>400	
~3	~6	~10	~18	~30	~50	~80	~120	~180	~250	~315	~400	~500	±2'
±0.12	±0.18	±0.22	±0.26	±0.31	±0.37	±0.57	±0.80	±0.93	±1.05	±1.15	±1.60	±2.20	

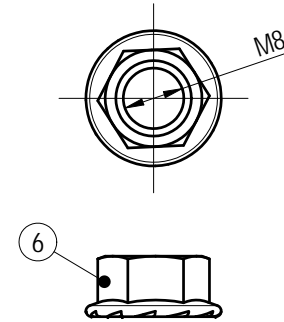

面板安装示意图/Panel installation diagram

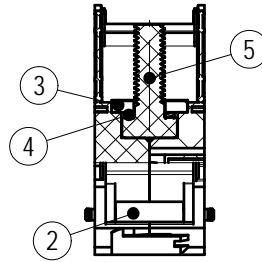
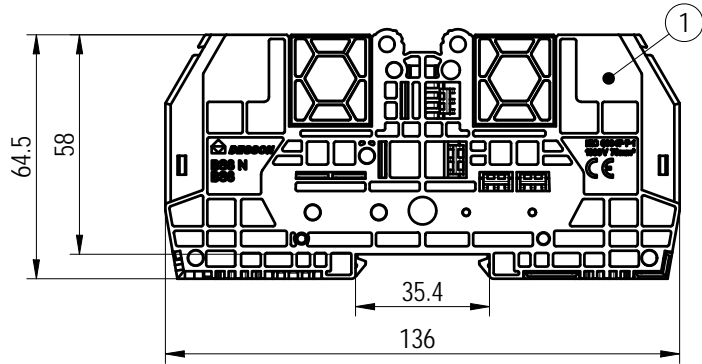
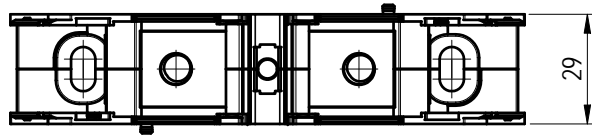
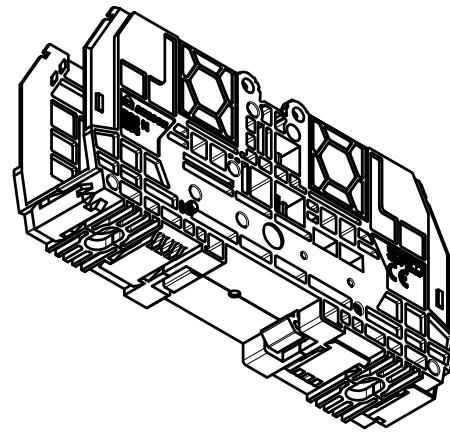
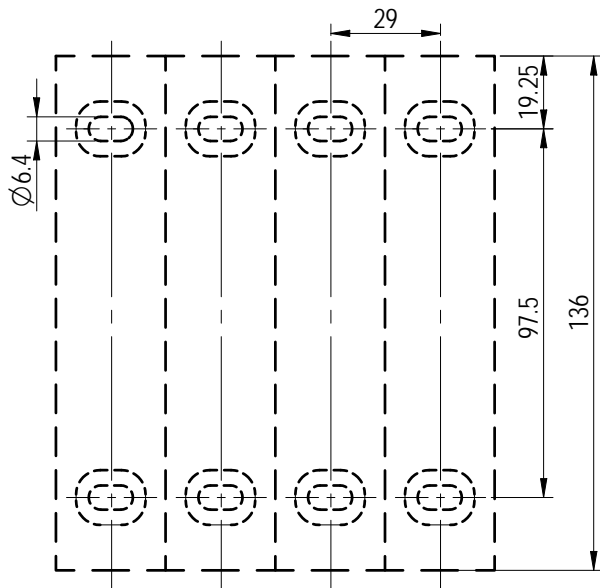

ITEM	NAME OF PART	MATERIAL	NOTES
6	Nut	Steel	M8/Zn Plated
5	Bolt	Steel	M8/Zn Plated
4	Lock Washer	Steel	M8/Zn Plated
3	Current carrier	Copper	Sn Plated
2	Mounting Bar	PA66	UL94V-0
1	Housing	PA66	UL94V-0

UL 标准/UL Standard:	B	C	D
额定电压/电流/Rated Voltage(V)/Current(A)	600/175	/	/
IEC 标准/IEC Standard:			
过压类别/Overvoltage Category/污染等级/Pollution Degree	III/3	III/2	II/2
额定电压/电流/Rated Voltage(V)/Current(A)	1000/192	/	/
额定脉冲电压(KV)/Rate Impulse Voltage(KV)	8	/	/
螺栓扭矩/Torque Tightening(N·m/Lb.in)	M8, 6-12/67.3-135.6		
固定螺钉规格/Fixing Screw Specifications	M6		
线径范围(硬线和软线)/Wire Range(rigid and flexible)(AWG/mm²)	16-2/0 / 2.5-70		
间距/Pitch(mm)/线数范围/Poles	29/N=01P		
剥线长度/Stripping length(mm)	Depends on Cold pressing		
使用温度范围/Operating temperature(°C)	-40~+105		
符合RoHS环保要求/Conform to RoHS	Yes		



APPD:	Li GL	2022-07-18
CHKD:	Ma EK	2022-07-18
DRFT:	Zhao QX	2022-07-18

MATERIAL:	SURFACE/COLOR:		
MAT NO./REV:	MAT STATUS: 批量		
NAME			
BS8 N-GY			

REV	ECN	DESCRIPTION	DRFT	DATE
00	/		Zhao QX	2022-07-18

DRAWING NO.	TYPE	DRAWING STATUS	SCALE	SHEET
200098786	CUSTOMER DRAWING	已发布	2:1	1/1

Transfer or duplication of this document as well as the utilization or communication of its content are prohibited unless expressly permitted in writing by DEGSON. All rights reserved for patent, utility model or design registrations. 除专利、实用新型、外观设计、商标、注册、著作权、专利权等权利外，其他权利均归 DEGSON 所有。未经 DEGSON 书面许可，不得复制或传播本文件内容。所有权利均归 DEGSON 保留。