

Features

- Supply Voltage: 2.7 V to 5.5 V
- Offset Voltage: ± 2 mV Maximum
- Bandwidth: 10 MHz, Slew Rate: 8 V/ μ s
- Low Power: 1.2 mA per channel
- Rail to rail input and output
- Low 1/f Noise: 10 nV/ $\sqrt{\text{Hz}}$ at 1 kHz
- No significant output glitch when power on and off
- -40°C to 125°C Operation Temperature Range

Applications

- Instrumentation
- Audio
- Motor Control
- Industrial control

Description

The TPA658X series is CMOS single, dual, and quad RRIO op-amps with low offset, low power and stable high frequency response. They incorporate 3PEAK's proprietary and patented design techniques to achieve high-performance AC with 10 MHz bandwidth, 8 V/ μ s slew rate and low distortion while drawing only 1.2 mA of quiescent current per amplifier. The TPA658X devices are suitable for audio and motor control application.

The TP658X series has isolation during power off even when the signal exits on the input pins as there is no ESD diode from the input pins to the positive power supply pin.

Typical Application Circuit

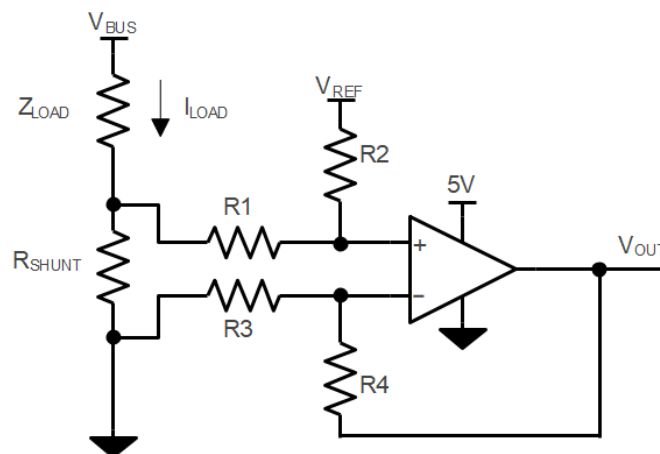

$$V_{OUT} = (I_{LOAD} \times R_{SHUNT}) \times (R2 / R1) + V_{REF}$$

$$\text{When } R3 = R1, R2 = R4, R_{SHUNT} \ll R1$$

Table of Contents

Features	1
Applications	1
Description	1
Typical Application Circuit	1
Table of Contents	2
Revision History	3
Pin Configuration	4
Specifications	5
Absolute Maximum Ratings.....	5
ESD, Electrostatic Discharge Protection	5
Recommended Operating Conditions	5
Thermal Information	6
Electrical Characteristics	7
Typical Performance Characteristics.....	9
Detailed Description	14
Overview.....	14
Functional Block Diagram	14
Feature Description	14
Application and Implementation	15
Low Side Current Sensing Application	15
Power Supply Recommendations	15
Tape and Reel Information	16
Package Outline Dimensions	18
DFN0.8X0.8-4 (5 Pin).....	18
SOT353 (SC70-5)	19
SOT23-5.....	20
SOP8.....	21
TSSOP8	22
MSOP8	23
SOP14.....	24
TSSOP14	25
Order Information	26

Revision History

Date	Revision	Notes
2021-11-20	Rev.A.0	Initial version
2022-04-30	Rev.A.1	Update package outline dimensions with 3PEAK new POD format, no change on the product.

Pin Configuration

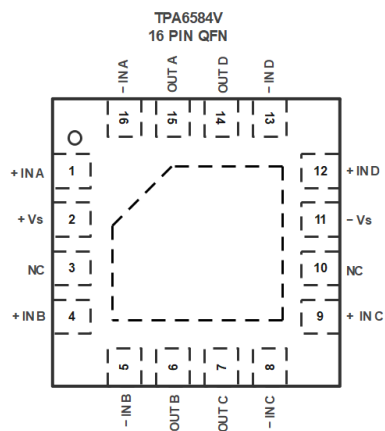
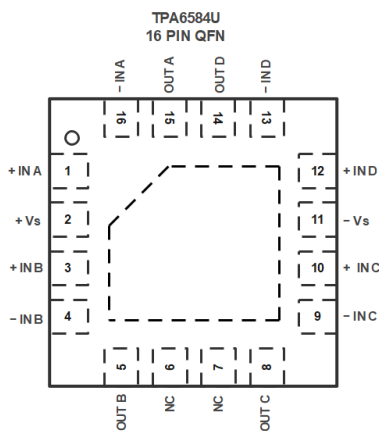
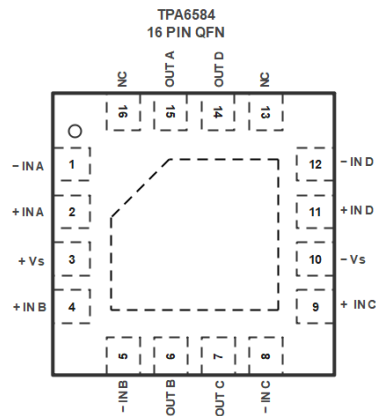
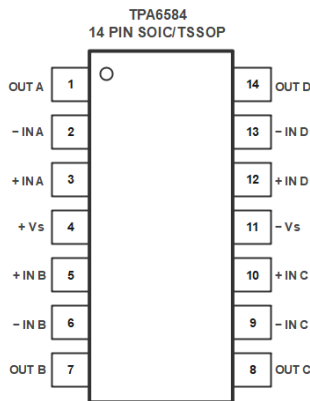
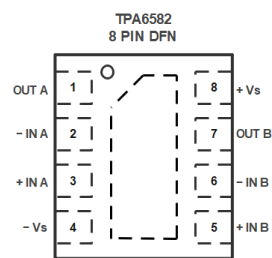
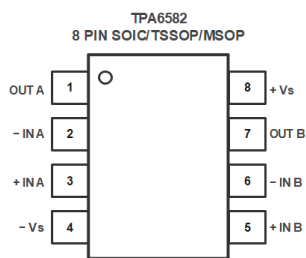
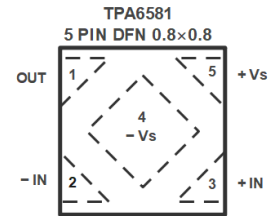
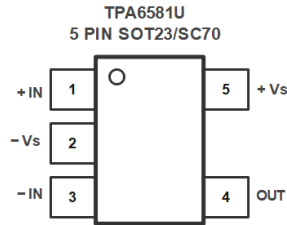
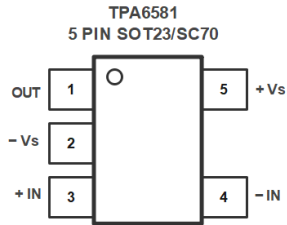

Note: The thermal pad of 8-Pin DFN and 16-Pin QFN is recommended to be left or connected to $-V_s$.

Specifications

Absolute Maximum Ratings

Over operating ambient temperature (unless otherwise noted) ⁽¹⁾

Parameter	Min	Max	Unit
Supply Voltage, (+V _s) – (–V _s)		6.5	V
Input Voltage	(–V _s) – 0.3	6.5	V
Differential Input Voltage	(–V _s) – (+V _s)	(+V _s) – (–V _s)	V
Input Current: +I _N , –I _N ⁽²⁾	–10	10	mA
Output Voltage	(–V _s) – 0.3	(+V _s) + 0.3	V
Output Short-Circuit Duration ⁽³⁾		Infinite	
Maximum Operating Junction Temperature		150	°C
Operating Temperature Range	–40	125	°C
Storage Temperature Range	–65	150	°C
Lead Temperature (Soldering, 10 sec)		260	°C

(1) Stresses beyond those listed under Absolute Maximum Ratings may cause permanent damage to the device. Exposure to any Absolute Maximum Rating condition for extended periods may affect device reliability and lifetime.

(2) The inputs are protected by ESD protection diodes to negative power supply. If the input extends more than 300 mV beyond the negative power supply, the input current should be limited to less than 10 mA.

(3) A heat sink may be required to keep the junction temperature below the absolute maximum. This depends on the power supply voltage and how many amplifiers are shorted. Thermal resistance varies with the amount of PC board metal connected to the package. The specified values are for short traces connected to the leads.

ESD, Electrostatic Discharge Protection

Symbol	Parameter	Condition	Minimum Level	Unit
HBM	Human Body Model ESD	ANSI/ESDA/JEDEC JS-001 ⁽¹⁾	3	kV
CDM	Charged Device Model ESD	ANSI/ESDA/JEDEC JS-002 ⁽²⁾	1	kV

(1) JEDEC document JEP155 states that 500-V HBM allows safe manufacturing with a standard ESD control process.

(2) JEDEC document JEP157 states that 250-V CDM allows safe manufacturing with a standard ESD control process.

Recommended Operating Conditions

Parameter	Min	Typ	Max	Unit
V _s	Supply Voltage, (+V _s) – (–V _s)	2.7	5.5	V
T _A	Operating Temperature Range	–40	125	°C

Thermal Information

Package Type	θ_{JA}	θ_{JC}	Unit
SOT353 (SC70-5)	400	150	°C/W
DFN0.8X0.8-4 (5Pin)	500	200	°C/W
SOT23-5	250	81	°C/W
SOP8	158	43	°C/W
MSOP8	210	45	°C/W
TSSOP8	191	44	°C/W
DFN1.5X1.5-8	200	100	°C/W
DFN2X2-8	100	60	°C/W
DFN3X3-8	75	54	°C/W
SOP14	120	36	°C/W
TSSOP14	180	35	°C/W

Electrical Characteristics

Test condition is at $V_S = 5\text{ V}$, $T_A = 25^\circ\text{C}$, $R_L = 10\text{ k}\Omega$, $C_L = 100\text{ pF}$, unless otherwise noted.

Symbol	Parameter	Conditions	Min	Typ	Max	Unit
Power Supply						
V_S	Supply Voltage Range		2.7		5.5	V
I_Q	Quiescent Current per Amplifier	$V_S = 2.7\text{ V to }5.5\text{ V}$		1.2	1.5	mA
		$V_S = 2.7\text{ V to }5.5\text{ V}, T_A = -40^\circ\text{C to }125^\circ\text{C}$			1.8	mA
PSRR	Power Supply Rejection Ratio	$V_S = 2.7\text{ V to }5.5\text{ V}$	90	120		dB
		$V_S = 2.7\text{ V to }5.5\text{ V}, T_A = -40^\circ\text{C to }125^\circ\text{C}$	85			dB
Input Characteristics						
V_{OS}	Input Offset Voltage	$V_{CM} = 0\text{ V to }2.5\text{ V}$	-2	0.1	2	mV
		$V_{CM} = 0\text{ V to }2.5\text{ V}, T_A = -40^\circ\text{C to }125^\circ\text{C}$	-2.5		2.5	mV
		$V_{CM} = 3.5\text{ V to }5\text{ V}$	-3	0.1	3	mV
		$V_{CM} = 3.5\text{ V to }5\text{ V}, T_A = -40^\circ\text{C to }125^\circ\text{C}$	-4		4	mV
$V_{OS\ TC}$	Input Offset Voltage Drift	$V_{CM} = 0\text{ V to }2.5\text{ V}, T_A = -40^\circ\text{C to }125^\circ\text{C}$		0.1	2	$\mu\text{V}/^\circ\text{C}$
		$V_{CM} = 3.5\text{ V to }5\text{ V}, T_A = -40^\circ\text{C to }125^\circ\text{C}$		0.3	5	$\mu\text{V}/^\circ\text{C}$
I_B	Input Bias Current	$V_{CM} = 2.5\text{ V}$		10		pA
		$V_{CM} = 2.5\text{ V}, T_A = -40^\circ\text{C to }125^\circ\text{C}$		100		pA
I_{OS}	Input Offset Current	$V_{CM} = 2.5\text{ V}$		10		pA
		$V_{CM} = 2.5\text{ V}, T_A = -40^\circ\text{C to }125^\circ\text{C}$		100		pA
C_{IN}	Input Capacitance	Differential Mode		2		pF
		Common Mode		4		pF
A_V	Open-loop Voltage Gain	$V_O = 0.1\text{ V to }4.9\text{ V}$	100	120		dB
		$V_O = 0.1\text{ V to }4.9\text{ V}, T_A = -40^\circ\text{C to }125^\circ\text{C}$	90			dB
V_{CMR}	Common-mode Input Voltage Range	$T_A = -40^\circ\text{C to }125^\circ\text{C}$	$(-V_S)$ - 0.1		$(+V_S)$ + 0.1	V
CMRR	Common Mode Rejection Ratio	$V_{CM} = 0\text{ V to }3.5\text{ V}$	70	90		dB
		$V_{CM} = 0\text{ V to }3.5\text{ V}, T_A = -40^\circ\text{C to }125^\circ\text{C}$	60			dB
		$V_{CM} = 0\text{ V to }5\text{ V}$	60	80		dB
		$V_{CM} = 0\text{ V to }5\text{ V}, T_A = -40^\circ\text{C to }125^\circ\text{C}$	55			dB
Output Characteristics						
	Output Voltage Swing from Positive Rail or Negative Rail	$V_S = 5.5\text{ V}, R_L = 10\text{ k}\Omega\text{ to }V_S/2$		3	10	mV
		$V_S = 5.5\text{ V}, R_L = 10\text{ k}\Omega\text{ to }V_S/2, T_A = -40^\circ\text{C to }125^\circ\text{C}$			15	mV
		$V_S = 5.5\text{ V}, R_L = 2\text{ k}\Omega\text{ to }V_S/2$		15	30	mV
		$V_S = 5.5\text{ V}, R_L = 2\text{ k}\Omega\text{ to }V_S/2, T_A = -40^\circ\text{C to }125^\circ\text{C}$			40	mV

Electrical Characteristics (Continued)

 Test condition is at $V_S = 5\text{ V}$, $T_A = 25^\circ\text{C}$, $R_L = 10\text{ k}\Omega$, $C_L = 100\text{ pF}$, unless otherwise noted.

Symbol	Parameter	Conditions	Min	Typ	Max	Unit
I_{sc}	Output Short-Circuit Current	$V_S = 5.5\text{ V}$, Source	110	135		mA
		$V_S = 5.5\text{ V}$, Source, $T_A = -40^\circ\text{C}$ to 125°C	80			mA
		$V_S = 5.5\text{ V}$, Sink	100	120		mA
		$V_S = 5.5\text{ V}$, Sink, $T_A = -40^\circ\text{C}$ to 125°C	70			mA
AC Specifications						
GBW	Gain-Bandwidth Product			10		MHz
SR	Slew Rate	$G = 1$, 2 V step	6	8		V/ μs
t_{OR}	Overload Recovery			400		ns
t_s	Settling Time, 0.1%	$G = 1$, 2 V step		200		ns
	Settling Time, 0.01%			250		ns
PM	Phase Margin	$R_L = 10\text{ k}\Omega$, $C_L = 100\text{ pF}$		40		$^\circ$
GM	Gain Margin	$R_L = 10\text{ k}\Omega$, $C_L = 100\text{ pF}$		8		dB
	Channel Separation	$f = 100\text{ kHz}$		120		dB
Noise Performance						
E_N	Input Voltage Noise	$f = 0.1\text{ Hz}$ to 10 Hz , $V_{CM} = 1\text{ V}$		0.3		μV_{RMS}
		$f = 0.1\text{ Hz}$ to 10 Hz , $V_{CM} = 4\text{ V}$		1		μV_{RMS}
e_N	Input Voltage Noise Density	$f = 1\text{ kHz}$, $V_{CM} = 1\text{ V}$		10		nV/ $\sqrt{\text{Hz}}$
		$f = 1\text{ kHz}$, $V_{CM} = 4\text{ V}$		33		nV/ $\sqrt{\text{Hz}}$
i_N	Input Current Noise	$f = 1\text{ kHz}$		20		fA/ $\sqrt{\text{Hz}}$
THD+N	Total Harmonic Distortion and Noise	$f = 1\text{ kHz}$, $G = 1$, $R_L = 10\text{ k}\Omega$, $V_{OUT} = 1\text{ V}_{RMS}$		0.001		%

Typical Performance Characteristics

Test condition: $V_S = 5\text{ V}$, $T_A = +25^\circ\text{C}$, test device is TPA6581-DF0R, unless otherwise noted.

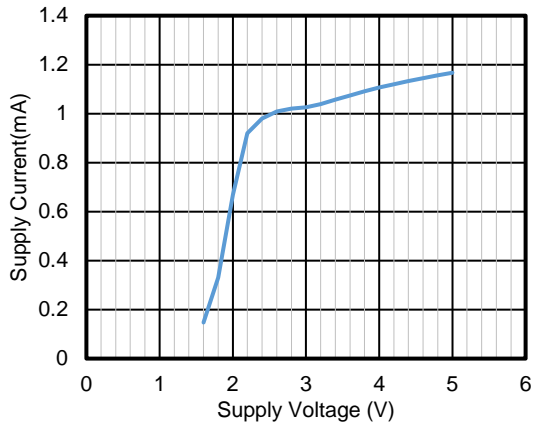

Figure 1 Supply Current vs Supply Voltage

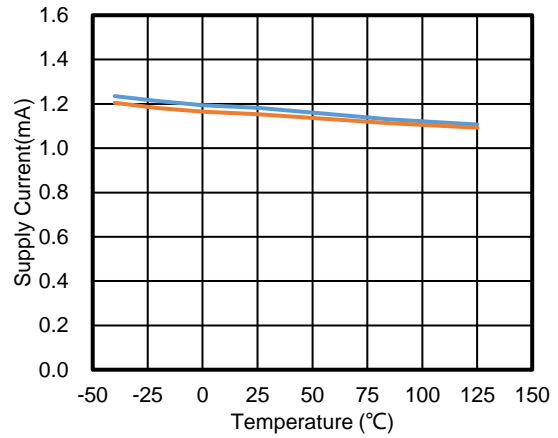

Figure 2 Supply Current vs Temperature

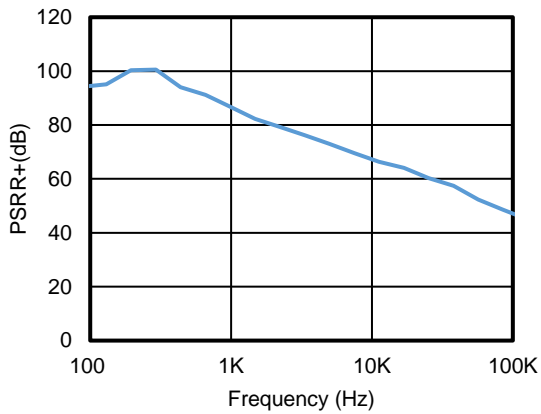

Figure 3 PSRR+ vs Frequency

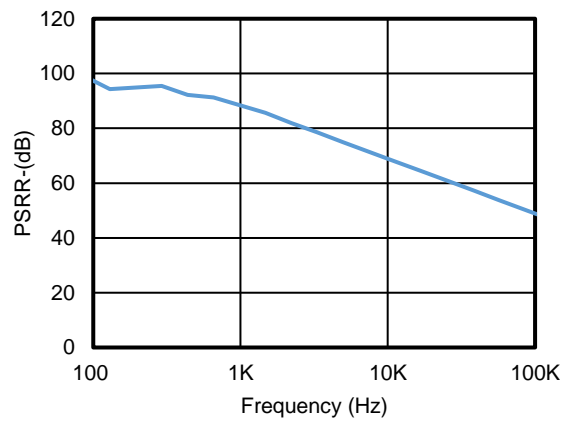

Figure 4 PSRR- vs Frequency

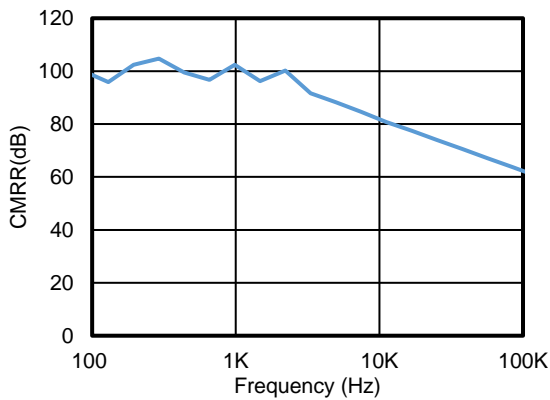

Figure 5 CMRR vs Frequency

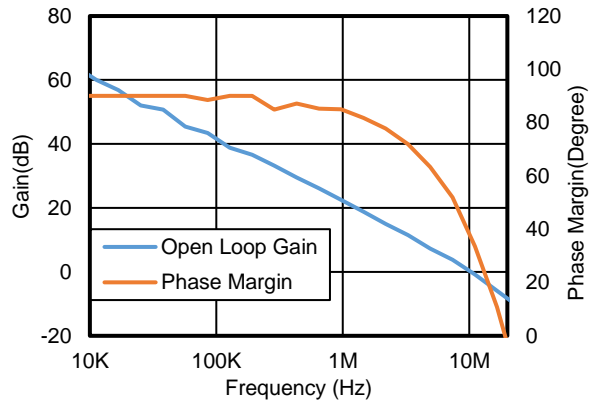

Figure 6 Open Loop Gain and Phase Margin vs Frequency, $R_L = 10\text{ k}\Omega$, $C_L = 100\text{ pF}$

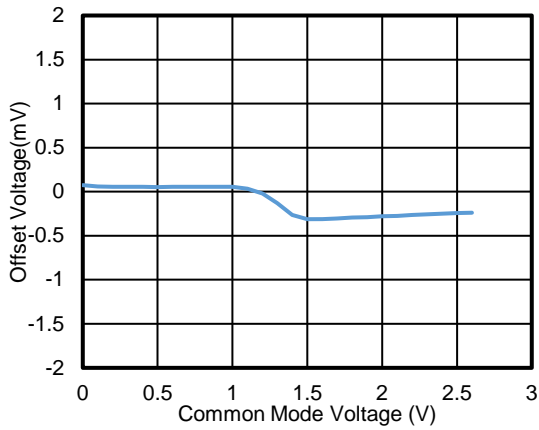

Figure 7 V_{OS} vs V_{CM} , $V_S = 2.7 V$

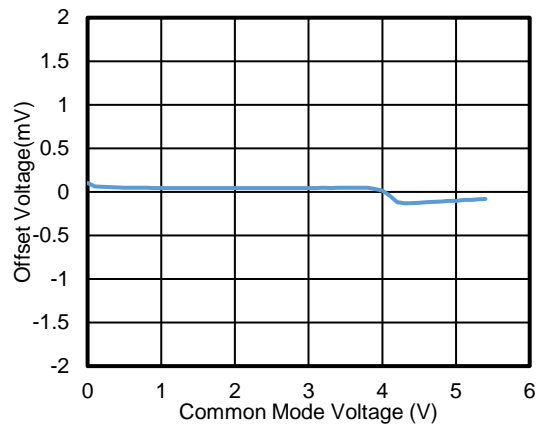

Figure 8 V_{OS} vs V_{CM} , $V_S = 5.5 V$

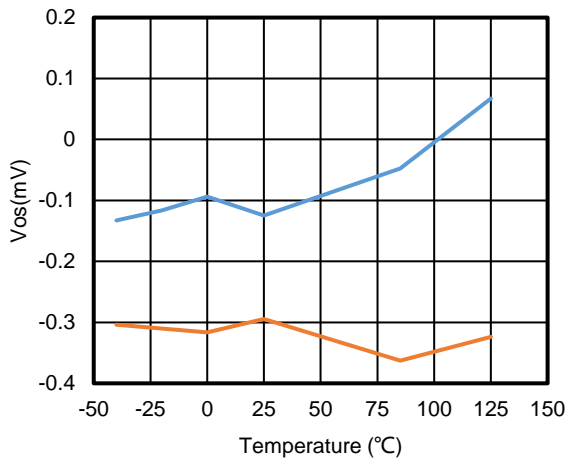

Figure 9 V_{OS} vs Temperature

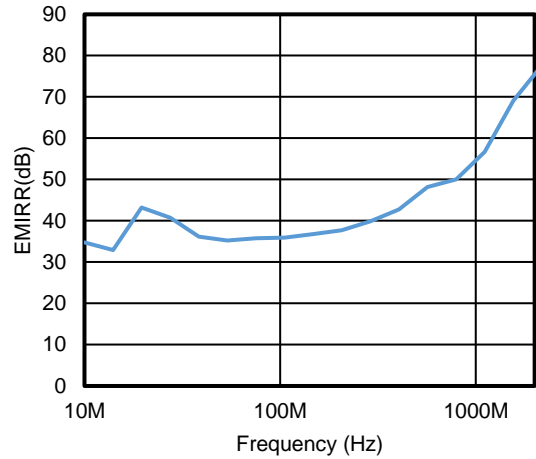

Figure 10 EMIRR vs Frequency

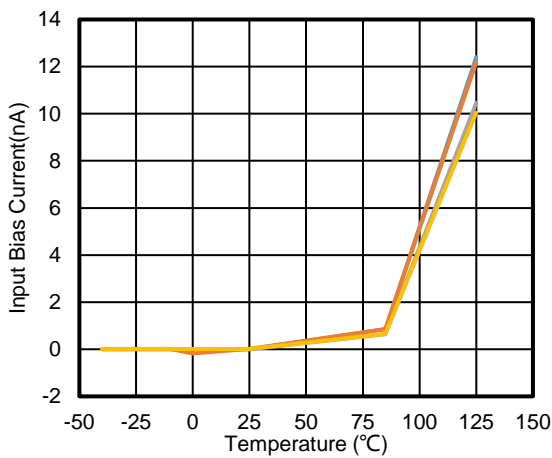

Figure 11 I_B vs Temperature

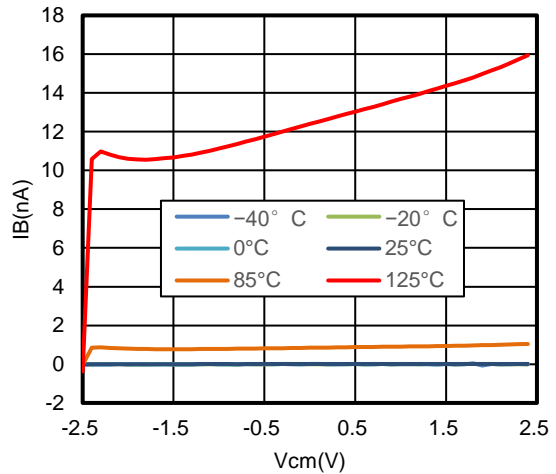

Figure 12 I_B vs Common Voltage,
 $(-V_S) = -2.5 V, (+V_S) = 2.5 V$

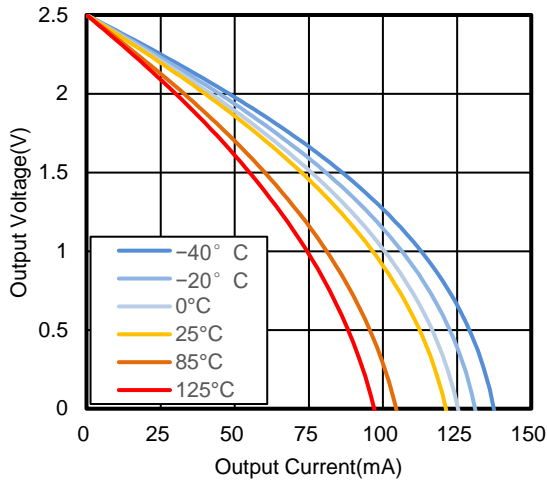

Figure 13 Output Voltage vs Output Current, $(-V_s) = -2.5\text{ V}, (+V_s) = 2.5\text{ V}$

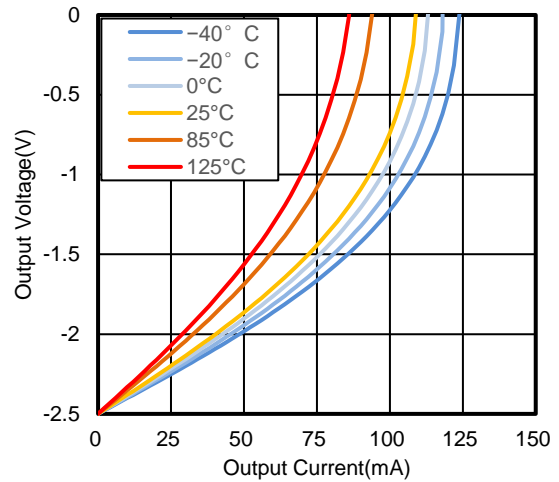

Figure 14 Output Voltage vs Output Current, $(-V_s) = -2.5\text{ V}, (+V_s) = 2.5\text{ V}$



Figure 15 Overload Recovery at Negative Rail



Figure 16 Overload Recovery at Positive Rail



Figure 17 Small Signal Step Response



Figure 18 Large Signal Step Response

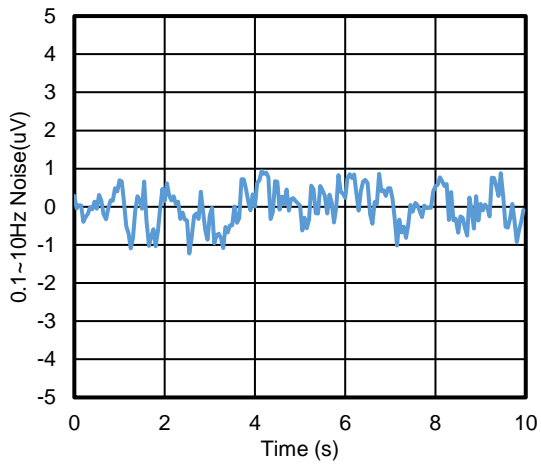

Figure 19 0.1 to 10 Hz Voltage Noise, $V_{CM} = 1\text{ V}$

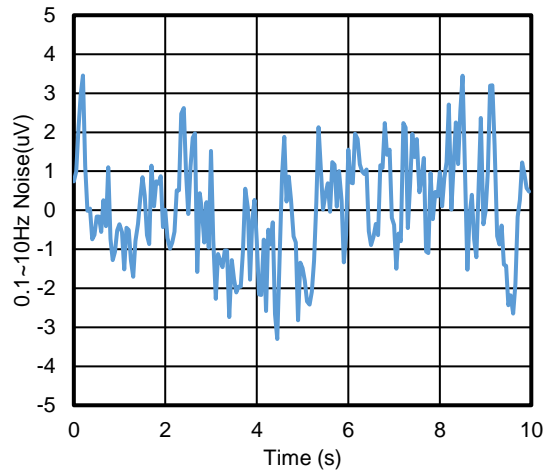

Figure 20 0.1 to 10 Hz Voltage Noise, $V_{CM} = 4\text{ V}$

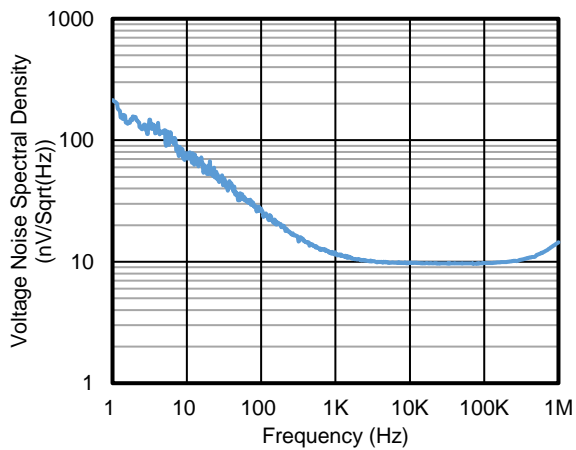

Figure 21 Voltage Noise Spectral Density vs Frequency, $V_{CM} = 1\text{ V}$

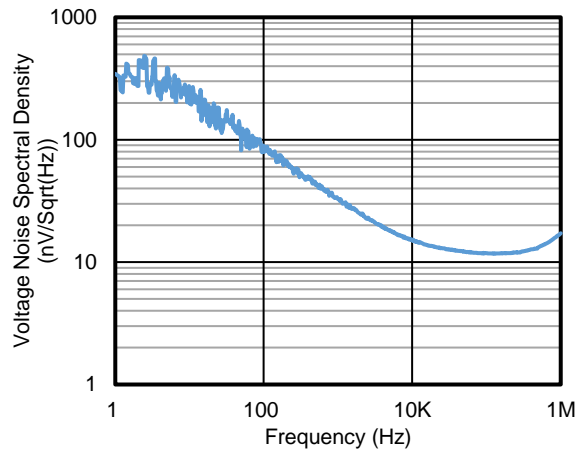

Figure 22 Voltage Noise Spectral Density vs Frequency, $V_{CM} = 4\text{ V}$

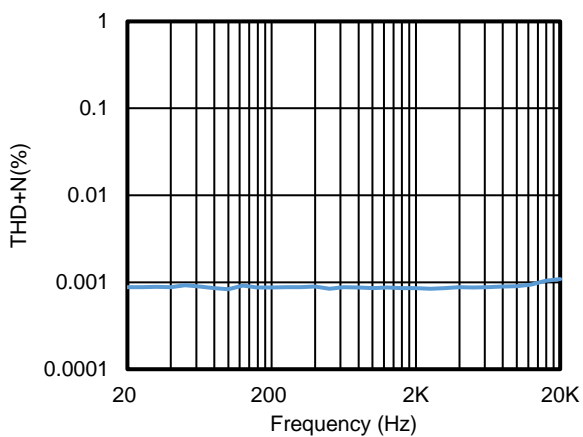

Figure 23 THD vs Frequency, $G = 1$, $V_{IN} = 1\text{ V}_{RMS}$

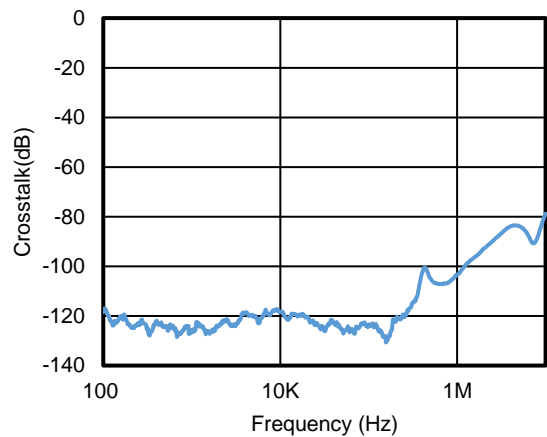

Figure 24 Crosstalk vs Frequency, TPA6582

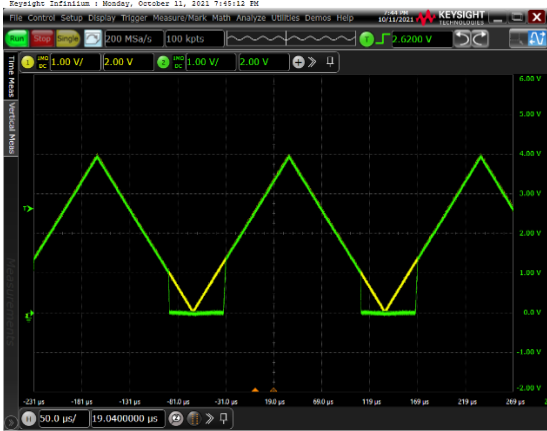

Figure 25 Power On and Off Behavior
 $G = 1$, $V_{IN} = 4\text{ V}$ during Power On and Off
 Yellow: + V_S ; Green: Output

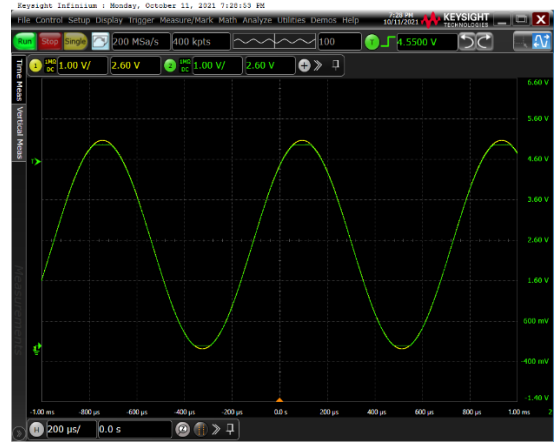

Figure 26 No Phase Reversal
 Yellow: Input; Green: Output

Detailed Description

Overview

The TPA658x series is a new family of low-power, rail-to-rail input and output op amplifiers. These devices operate from 2.7 V to 5.5 V, are unity-gain stable and designed for a wide range of general-purpose applications.

Functional Block Diagram

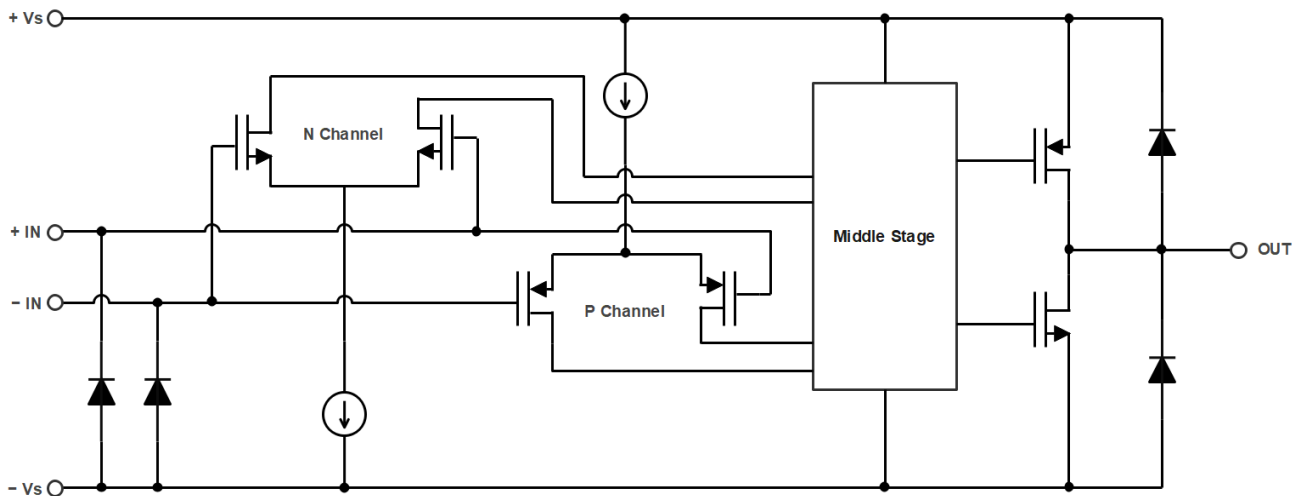

Figure 27 Functional Block Diagram

Feature Description

Operating Voltage

The TPA658x family of op amplifiers is designed for single supply operation from 2.7 V to 5.5 V or dual supply operation from ± 1.35 V to ± 2.75 V.

Rail-to-Rail Input

The input common-mode voltage range of the TPA658x family extends 100 mV beyond the supply rails. This performance is achieved with a complementary input stage: a P-channel input differential pair in parallel with an N-channel differential pair. The P-channel pair is active for inputs from 100 mV below the negative supply to approximately $(+V_s) - 1.5$ V, whereas the N-channel pair is active for input voltages close to the positive rail, typically $(+V_s) - 1.5$ V to 100 mV above the positive supply. There is around 200 mV transition region at $(+V_s) - 1.5$ V where both pairs are on. Within this transition region, PSRR, CMRR, offset voltage, offset drift, and THD can degrade comparing to that operating outside this region.

Rail-to-Rail Output

The TPA658x family delivers rail-to-rail output swing capability with a class-AB output stage. Different load conditions change the ability of the amplifier to swing close to the rails.

No ESD Diode between Input Pins and (+Vs) Pin

There is no ESD diode between input pins and (+Vs) pin, so the voltage at input pins can be applied from 0 V to 5.5 V regardless of the voltage at (+Vs) pin. The feature provides isolation when the device is power off and the signal still exists at input pin.

Application and Implementation

NOTE

Information in the following applications sections is not part of the 3PEAK's component specification and 3PEAK does not warrant its accuracy or completeness. 3PEAK's customers are responsible for determining suitability of components for their purposes. Customers should validate and test their design implementation to confirm system functionality.

Low Side Current Sensing Application

Figure 28 shows the TPA658x configured in a low-side current sensing application. The low-side current sensing method consists of placing a sense resistor between the load and the circuit ground. The voltage dropping across the resistor is amplified by different amplifier circuits with TPA658x. The V_{REF} can be used to add bias voltage to output voltage. Particular attention must be paid to the matching and precision of R1, R2, R3, and R4, to maximize the accuracy of the measurement.

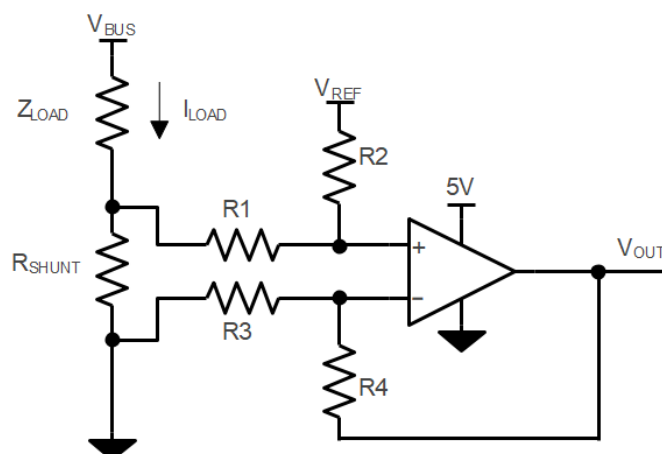

$$V_{OUT} = (I_{LOAD} \times R_{SHUNT}) \times (R2 / R1) + V_{REF}$$

$$\text{When } R3 = R1, R2 = R4, R_{SHUNT} \ll R1$$

Figure 28 Dual Supply Operation Connections

Power Supply Recommendations

Place 0.1- μ F bypass capacitors close to the power-supply pins for reducing coupling errors from the noisy or high impedance power supplies.

Tape and Reel Information

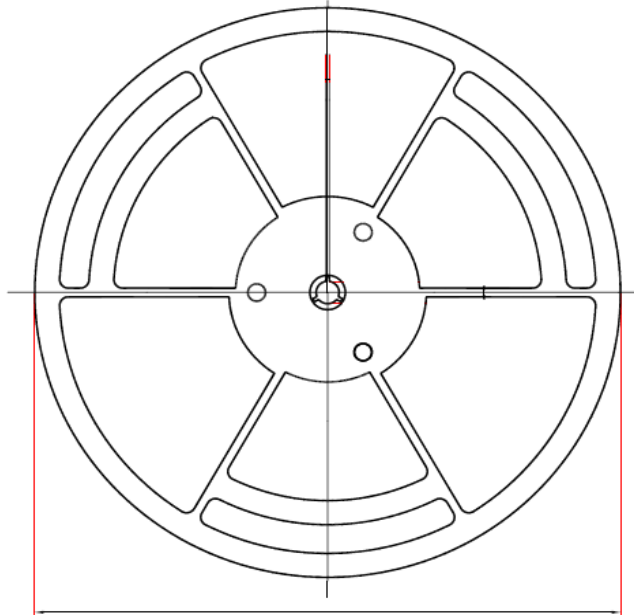

D1: Reel Diameter



W1: Reel Width

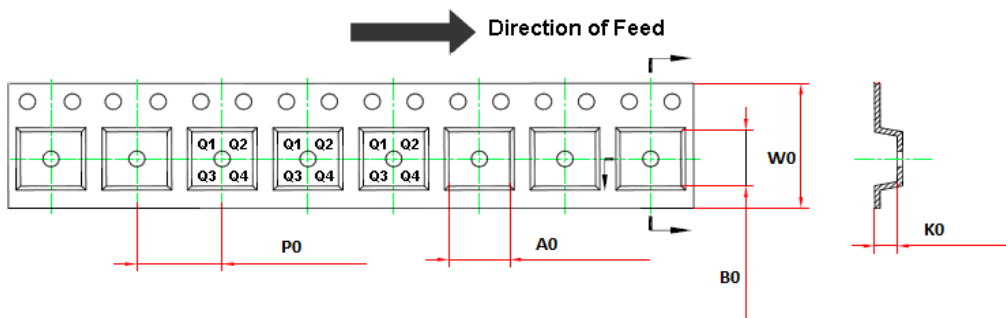

Order Number	Package	D1 (mm)	W1 (mm)	A0 (mm)	B0 (mm)	K0 (mm)	P0 (mm)	W0 (mm)	Pin1 Quadrant
TPA6581-DF0R	DFN0.8X0.8-4 (5 Pin)	180.0	12.0	0.91	0.91	0.5	2.0	8.0	Q2
TPA6581-SC5R	SOT353 (SC70-5)	178.0	12.3	2.4	2.5	1.2	4.0	8.0	Q3
TPA6581U-SC5R	SOT353 (SC70-5)	178.0	12.3	2.4	2.5	1.2	4.0	8.0	Q3
TPA6581-S5TR	SOT23-5	180.0	13.1	3.2	3.2	1.4	4.0	8.0	Q3
TPA6581U-S5TR	SOT23-5	180.0	13.1	3.2	3.2	1.4	4.0	8.0	Q3
TPA6582-SO1R	SOP8	330.0	17.6	6.4	5.4	2.1	8.0	12.0	Q1
TPA6582-DF4R	DFN2X2-8	180.0	13.1	2.3	2.3	1.1	4.0	8.0	Pending
TPA6582-F1R	DFN1.5X1.5-8	178.0	12.3	1.7	1.7	0.75	4.0	8.0	Pending
TPA6582-F2R	DFN3X3-8	330.0	17.6	3.35	3.35	1.13	8.0	12.0	Pending
TPA6582-TS1R	TSSOP8	330.0	17.6	6.8	3.3	1.2	8.0	12.0	Q1
TPA6582-VS1R	MSOP8	330.0	17.6	5.2	3.3	1.5	8.0	12.0	Q1
TPA6584-SO2R	SOP14	330.0	21.6	6.5	9.0	2.1	8.0	16.0	Q1
TPA6584-TS2R	TSSOP14	330.0	17.6	6.8	5.4	1.2	8.0	12.0	Q1
TPA6584-QF4R	QFN3X3-16	330.0	17.6	3.4	3.4	1.1	8.0	12.0	Pending
TPA6584U-QF4R	QFN3X3-16	330.0	17.6	3.4	3.4	1.1	8.0	12.0	Pending
TPA6584V-QF4R	QFN3X3-16	330.0	17.6	3.4	3.4	1.1	8.0	12.0	Pending

Package Outline Dimensions

DFN0.8X0.8-4 (5 Pin)

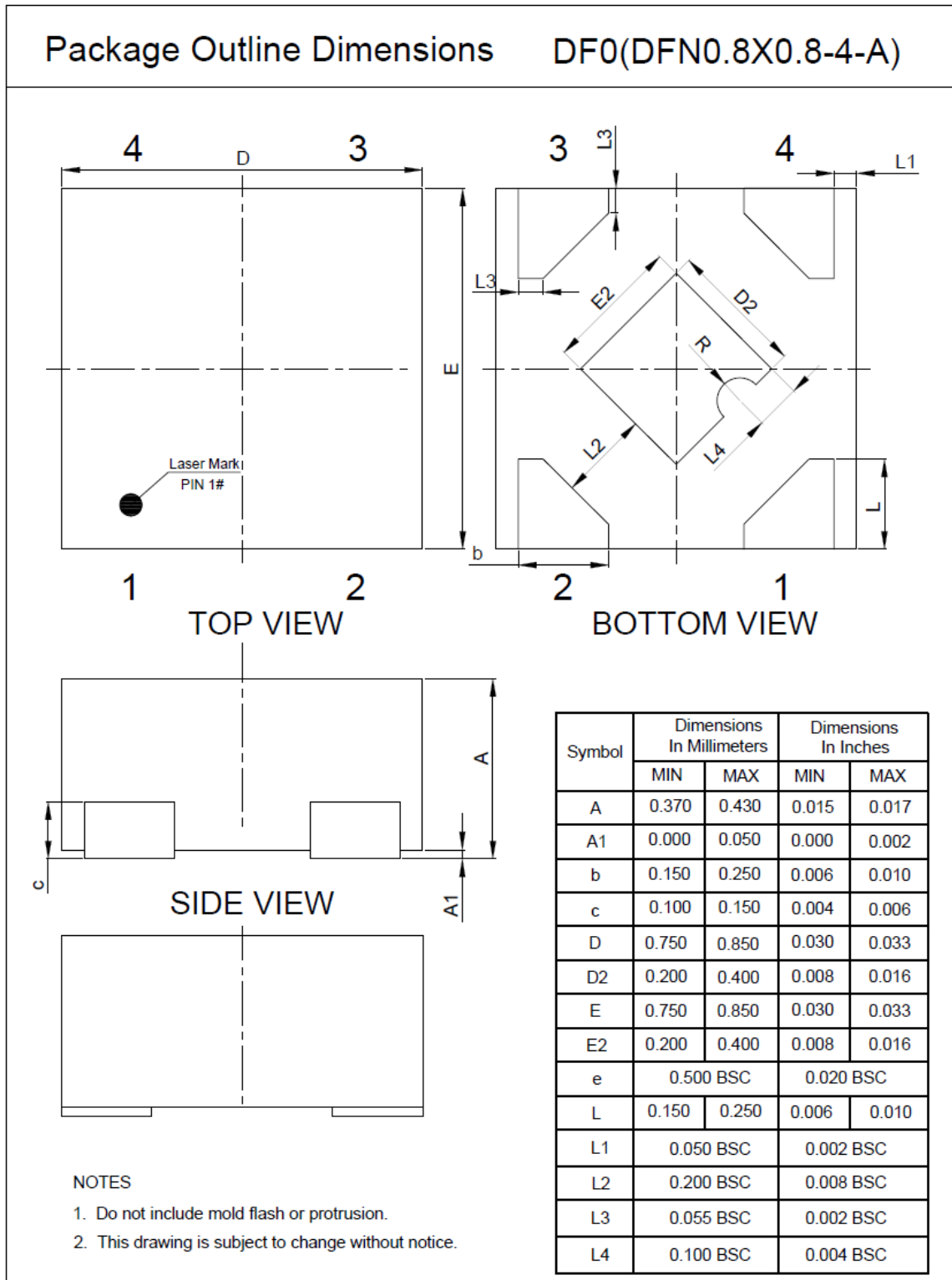

SOT353 (SC70-5)

Package Outline Dimensions

SC5(SOT353-5-A)

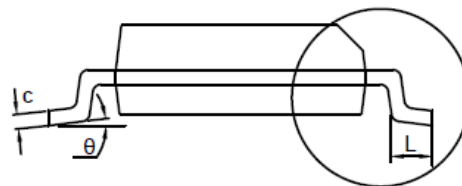
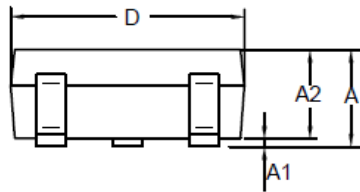
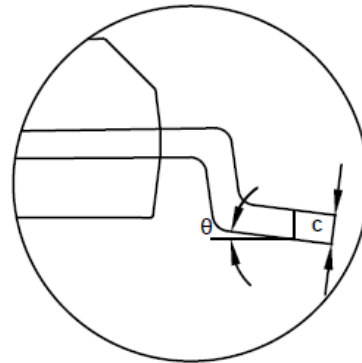
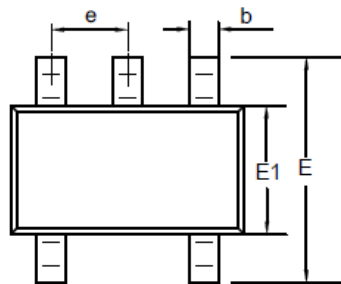

Symbol	Dimensions In Millimeters		Dimensions In Inches	
	MIN	MAX	MIN	MAX
A	0.850	1.100	0.033	0.043
A1	0.000	0.100	0.000	0.004
A2	0.800	1.000	0.031	0.039
b	0.150	0.350	0.006	0.014
c	0.110	0.230	0.004	0.009
D	2.000	2.200	0.079	0.087
E	2.150	2.450	0.085	0.096
E1	1.150	1.350	0.045	0.053
e	0.650 BSC		0.026 BSC	
L	0.260	0.460	0.010	0.018
θ	0	8	0	8

NOTES

1. Do not include mold flash or protrusion.
2. This drawing is subject to change without notice.

SOT23-5

Package Outline Dimensions

S5T(SOT23-5-A)

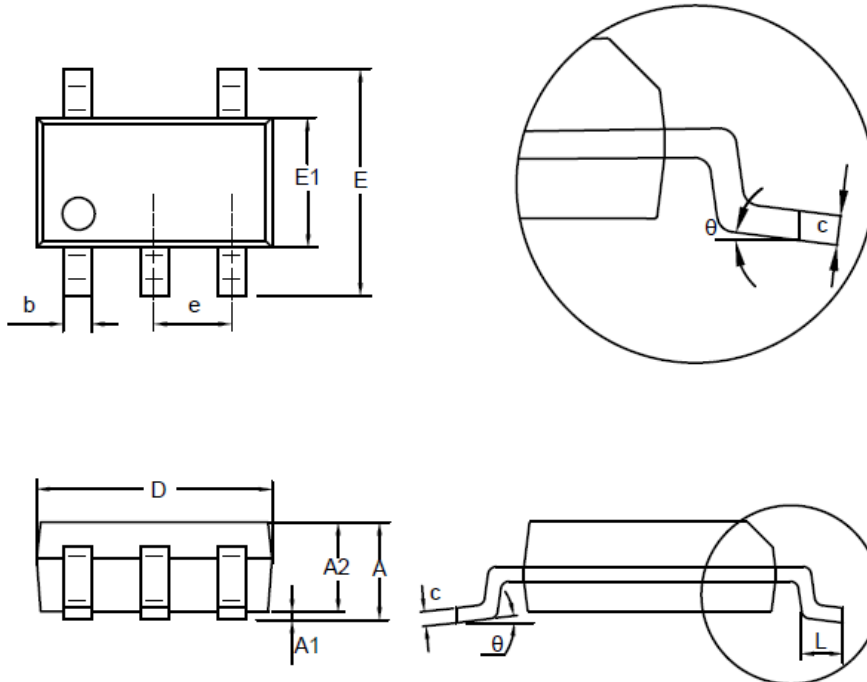

Symbol	Dimensions In Millimeters		Dimensions In Inches	
	MIN	MAX	MIN	MAX
A	1.050	1.250	0.041	0.049
A1	0.000	0.150	0.000	0.006
A2	1.000	1.200	0.039	0.047
b	0.280	0.500	0.011	0.020
c	0.100	0.230	0.004	0.009
D	2.820	3.020	0.111	0.119
E	2.600	3.000	0.102	0.118
E1	1.500	1.720	0.059	0.068
e	0.950 BSC		0.037 BSC	
L	0.300	0.600	0.012	0.024
θ	0	8°	0	8°

NOTES

1. Do not include mold flash or protrusion.
2. This drawing is subject to change without notice.

SOP8

Package Outline Dimensions

SO1(SOP-8-A)

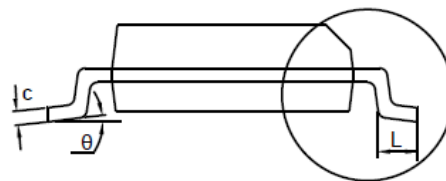
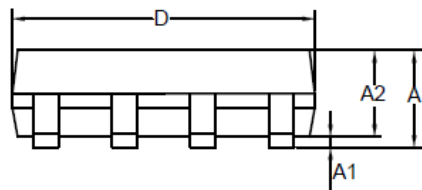
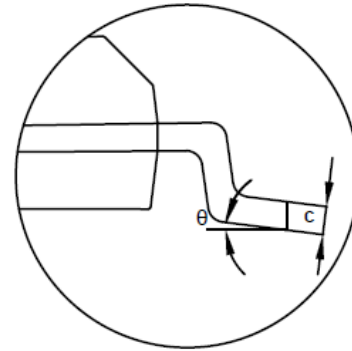
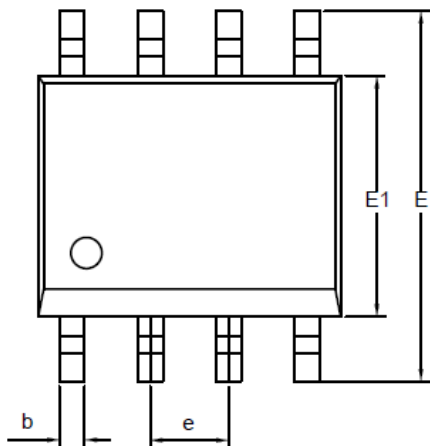

Symbol	Dimensions In Millimeters		Dimensions In Inches	
	MIN	MAX	MIN	MAX
A	1.350	1.750	0.053	0.069
A1	0.050	0.250	0.002	0.010
A2	1.250	1.550	0.049	0.061
b	0.330	0.510	0.013	0.020
c	0.170	0.250	0.007	0.010
D	4.700	5.100	0.185	0.201
E	5.800	6.200	0.228	0.244
E1	3.800	4.000	0.150	0.157
e	1.270 BSC		0.050 BSC	
L	0.400	1.000	0.016	0.039
θ	0	8°	0	8°

NOTES

1. Do not include mold flash or protrusion.
2. This drawing is subject to change without notice.

TSSOP8

Package Outline Dimensions

TS1(TSSOP-8-A)

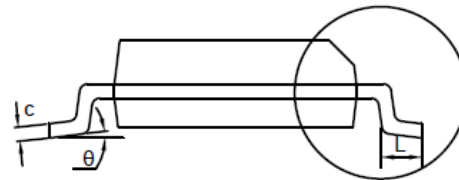
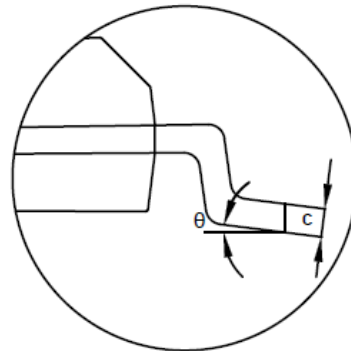
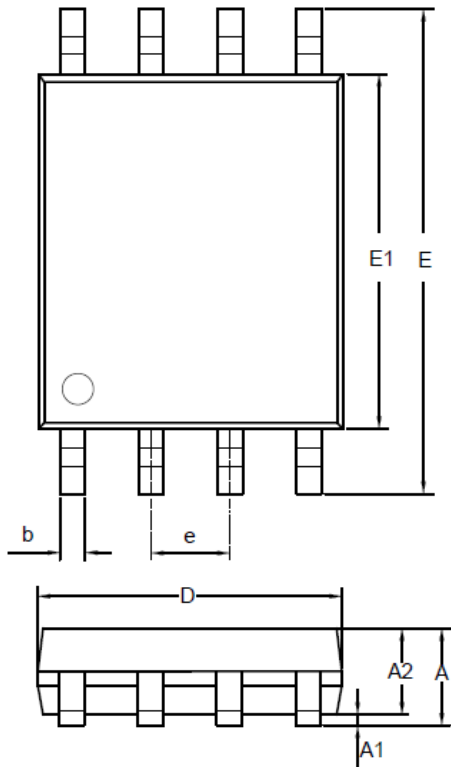

Symbol	Dimensions In Millimeters		Dimensions In Inches	
	MIN	MAX	MIN	MAX
A	0.900	1.200	0.035	0.047
A1	0.050	0.150	0.002	0.006
A2	0.800	1.050	0.031	0.041
b	0.190	0.300	0.007	0.012
c	0.090	0.200	0.004	0.008
D	2.900	3.100	0.114	0.122
E	6.200	6.600	0.244	0.260
E1	4.300	4.500	0.169	0.177
e	0.650 BSC		0.026 BSC	
L	0.450	0.750	0.018	0.030
θ	0	8°	0	8°

NOTES

1. Do not include mold flash or protrusion.
2. This drawing is subject to change without notice.

MSOP8

Package Outline Dimensions

VS1(MSOP-8-A)

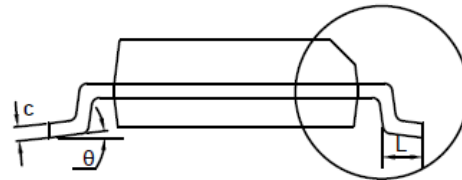
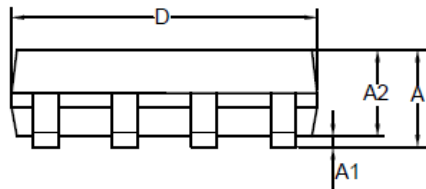
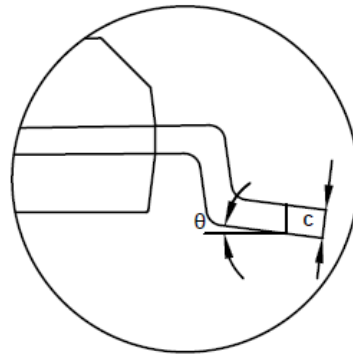
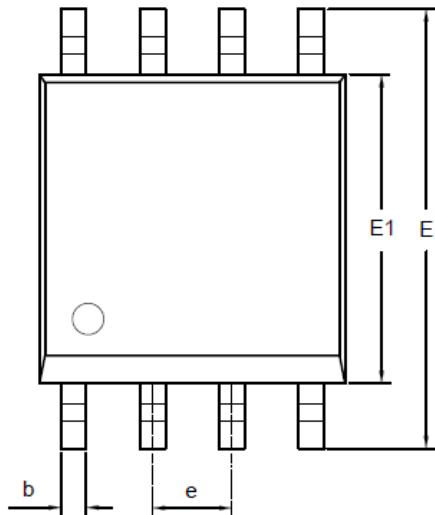

Symbol	Dimensions In Millimeters		Dimensions In Inches	
	MIN	MAX	MIN	MAX
A	0.800	1.100	0.031	0.043
A1	0.050	0.150	0.002	0.006
A2	0.750	0.950	0.030	0.037
b	0.250	0.380	0.010	0.015
c	0.090	0.230	0.004	0.009
D	2.900	3.100	0.114	0.122
E	4.700	5.100	0.185	0.201
E1	2.900	3.100	0.114	0.122
e	0.650 BSC		0.026 BSC	
L	0.400	0.800	0.016	0.031
θ	0	8°	0	8°

NOTES

1. Do not include mold flash or protrusion.
2. This drawing is subject to change without notice.

SOP14

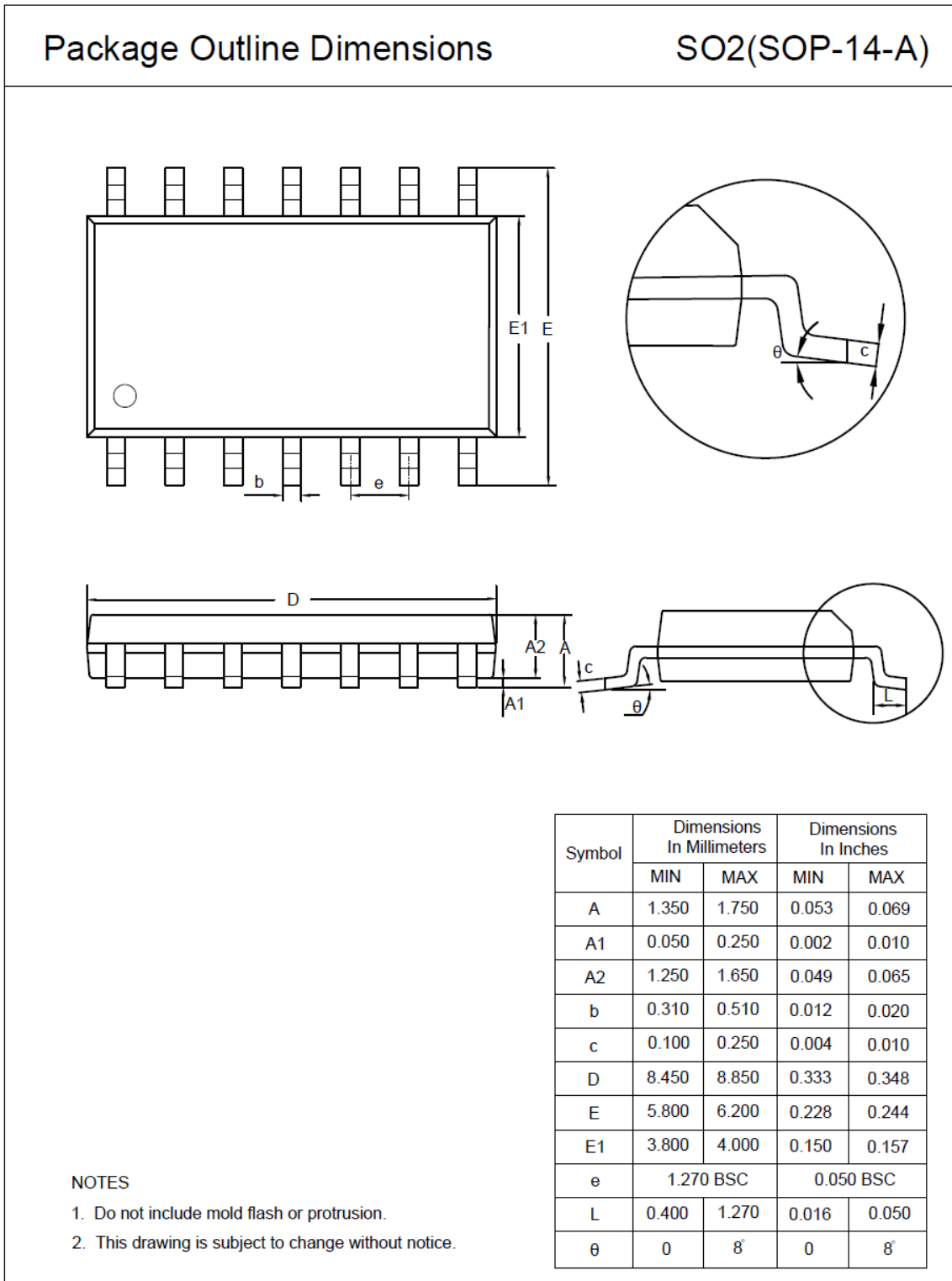

TSSOP14

Package Outline Dimensions

TS2(TSSOP-14-A)

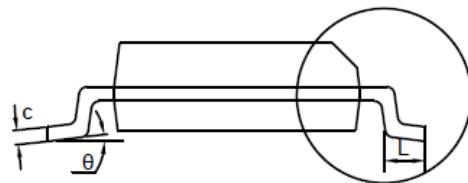
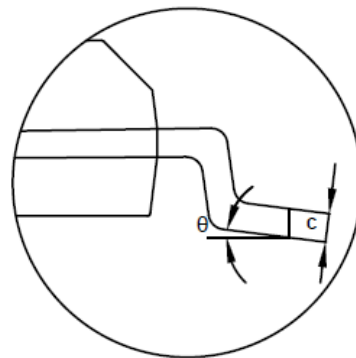
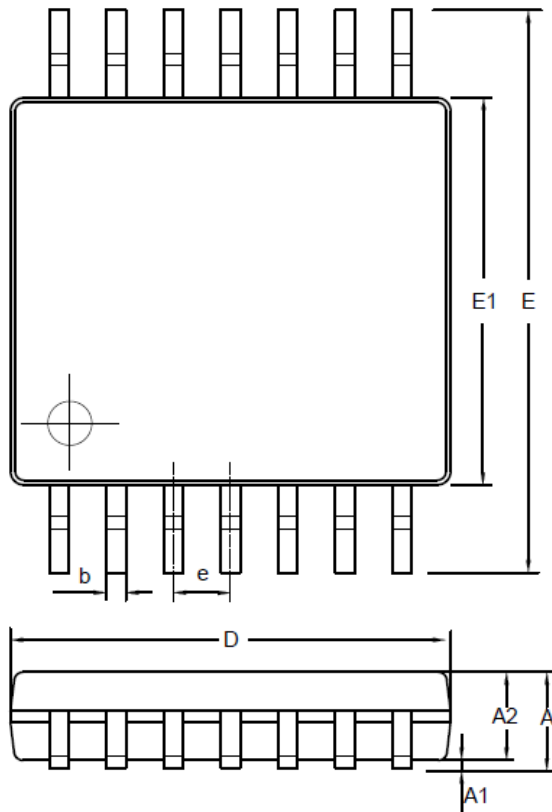

Symbol	Dimensions In Millimeters		Dimensions In Inches	
	MIN	MAX	MIN	MAX
A	0.900	1.200	0.035	0.047
A1	0.050	0.150	0.002	0.006
A2	0.800	1.050	0.031	0.041
b	0.190	0.300	0.007	0.012
c	0.090	0.200	0.004	0.008
D	4.900	5.100	0.193	0.201
E	6.200	6.600	0.244	0.260
E1	4.300	4.500	0.169	0.177
e	0.650 BSC		0.026 BSC	
L	0.450	0.750	0.018	0.030
θ	0	8°	0	8°

NOTES

1. Do not include mold flash or protrusion.
2. This drawing is subject to change without notice.

Order Information

Order Number	Operating Temperature Range	Package	Marking Information	MSL	Transport Media, Quantity	Eco Plan
TPA6581-DF0R	-40 to 125°C	DFN0.8X0.8-4 (5 Pin)	8	3	Tape and Reel, 12000	Green
TPA6581-SC5R ⁽¹⁾	-40 to 125°C	SOT353 (SC70-5)	658	3	Tape and Reel, 3000	Green
TPA6581U-SC5R ⁽¹⁾	-40 to 125°C	SOT353 (SC70-5)	68U	3	Tape and Reel, 3000	Green
TPA6581-S5TR ⁽¹⁾	-40 to 125°C	SOT23-5	658	3	Tape and Reel, 3000	Green
TPA6581U-S5TR ⁽²⁾	-40 to 125°C	SOT23-5	68U	3	Tape and Reel, 3000	Green
TPA6582-SO1R ⁽¹⁾	-40 to 125°C	SOP8	A6582	3	Tape and Reel, 4000	Green
TPA6582-DF4R ⁽²⁾	-40 to 125°C	DFN2X2-8	658	3	Tape and Reel, 3000	Green
TPA6582-F1R ⁽²⁾	-40 to 125°C	DFN1.5X1.5-8	68	3	Tape and Reel, 3000	Green
TPA6582-F2R ⁽²⁾	-40 to 125°C	DFN3X3-8	658	3	Tape and Reel, 3000	Green
TPA6582-TS1R ⁽¹⁾	-40 to 125°C	TSSOP8	A6582	3	Tape and Reel, 3000	Green
TPA6582-VS1R ⁽¹⁾	-40 to 125°C	MSOP8	A6582	3	Tape and Reel, 3000	Green
TPA6584-SO2R ⁽¹⁾	-40 to 125°C	SOP14	A6584	3	Tape and Reel, 2500	Green
TPA6584-TS2R ⁽¹⁾	-40 to 125°C	TSSOP14	A6584	3	Tape and Reel, 3000	Green
TPA6584-QF4R ⁽²⁾	-40 to 125°C	QFN3X3-16	6584	3	Tape and Reel, 4000	Green
TPA6584U-QF4R ⁽²⁾	-40 to 125°C	QFN3X3-16	658U	3	Tape and Reel, 4000	Green
TPA6584V-QF4R ⁽²⁾	-40 to 125°C	QFN3X3-16	658V	3	Tape and Reel, 4000	Green

(1) Can provide sample in 2 months.

(2) Future product, contact 3PEAK factory for more information and sample.

Green: 3PEAK defines "Green" to mean RoHS compatible and free of halogen substances.

 **3PEAK and the 3PEAK logo are registered trademarks of 3PEAK INCORPORATED. All other trademarks are the property of their respective owners.**