

VIDEO CONTROL COMBINATION CIRCUIT

with automatic cut-off control

GENERAL DESCRIPTION

The TDA4580 is a monolithic integrated circuit which performs video control functions in television receivers with a colour difference interface. For example it operates in conjunction the multistandard colour decoder TDA4555. The required input signals are: luminance and negative colour difference $-(R-Y)$ and $-(B-Y)$, and a 3-level sandcastle pulse for control purposes. Analogue RGB signals can be inserted from two sources. One with full performance adjustment possibilities. RGB output signals are available for driving the video output stages. This circuit provides automatic cut-off control of the picture tube.

Features

- Capacitive coupling of the colour difference, luminance and RGB input signals with black level clamping
- Two sets of analogue RGB inputs via fast switch 1 and fast switch 2
- First RGB inputs and fast switch 1 in accordance with peritelevision connector specification
- Saturation, contrast and brightness control acting on first RGB inputs
- Brightness control acting on second RGB inputs
- Equal black levels for television and inserted signals
- Clamping, horizontal and vertical blanking, and timing of automatic cut-off, controlled by a 3-level sandcastle pulse
- Automatic cut-off control with compensation for leakage current of the picture tube
- Measuring pulses of cut-off control start immediately after end of vertical part of sandcastle pulse
- Three selectable blanking intervals for PAL, SECAM and NTSC/PAL-M
- Two switch-on delays for run-in without discolouration
- Adjustable peak drive limiter
- Average beam current limiter
- G-Y and RGB matrix coefficients selectable for PAL/SECAM and NTSC (correction for FCC primaries)
- Bandwidth 10 MHz (typ.)
- Emitter-follower outputs for driving the RGB output stages

QUICK REFERENCE DATA

Supply voltage (pin 6)	$V_p = V_{6-24}$	typ.	12 V
Supply current (pin 6)	$I_p = I_6$	typ.	110 mA
Luminance input (pin 15)			
Composite video input signal (VBS) (peak-to-peak value)	$V_{15-24(p-p)}$	typ.	0,45 V
Colour difference input signals (peak-to-peak values)			
$-(B-Y)$	$V_{18-24(p-p)}$	typ.	1,33 V
$-(R-Y)$	$V_{17-24(p-p)}$	typ.	1,05 V
Inserted RGB signals (black to white values)	$V_{14, 13, 12-24}$	typ.	0,7 V
Inserted RGB signals for teletext use (black to white values)	$V_{23, 22, 21-24}$	typ.	1 V
Three-level sandcastle pulse (required input voltage)	V_{10-24}	typ.	2,5/4,5/8,0 V

PACKAGE OUTLINE

28-lead DIL; plastic (SOT117).

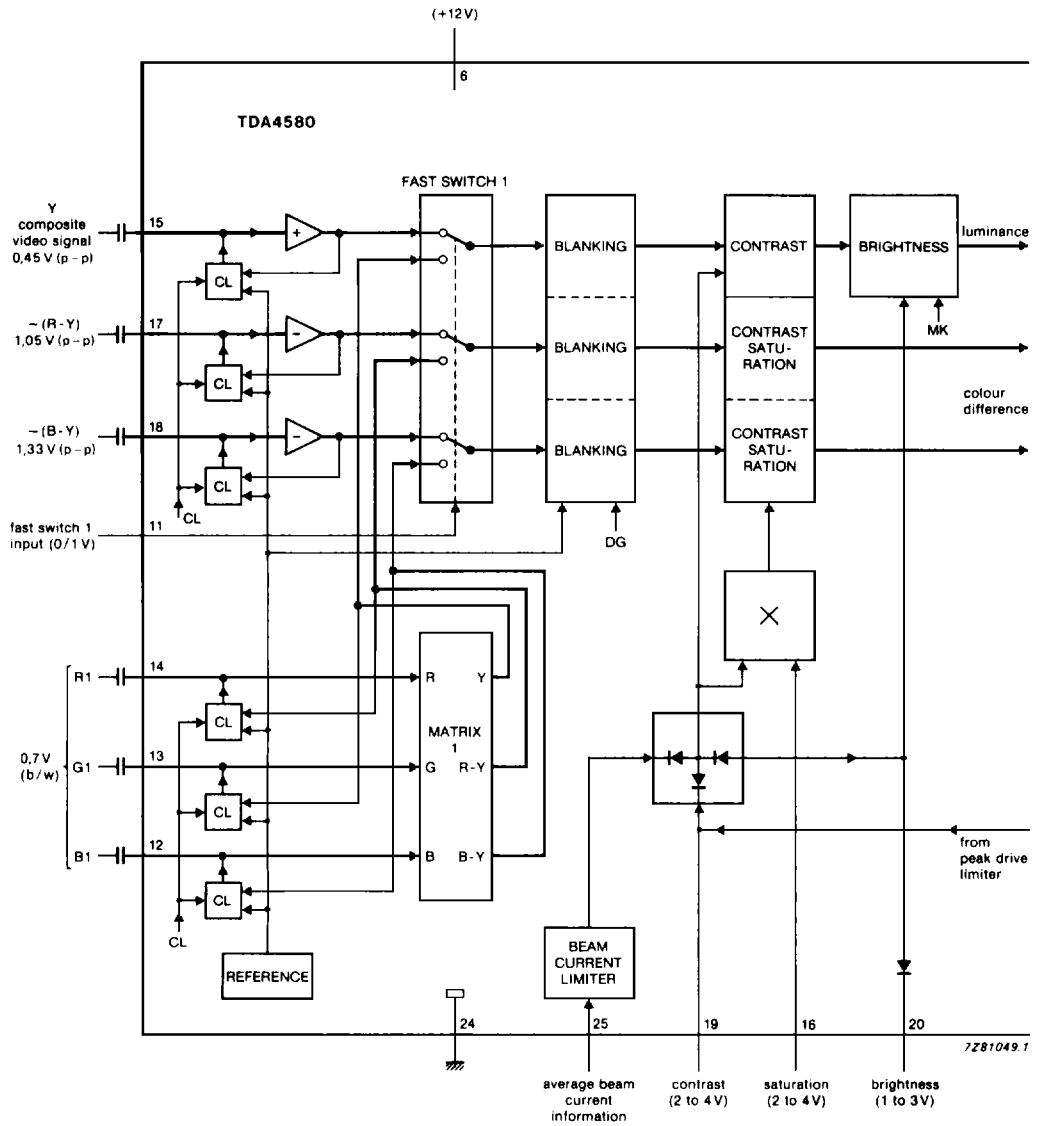

Fig. 1a Part of block diagram; continued in Fig. 1b.

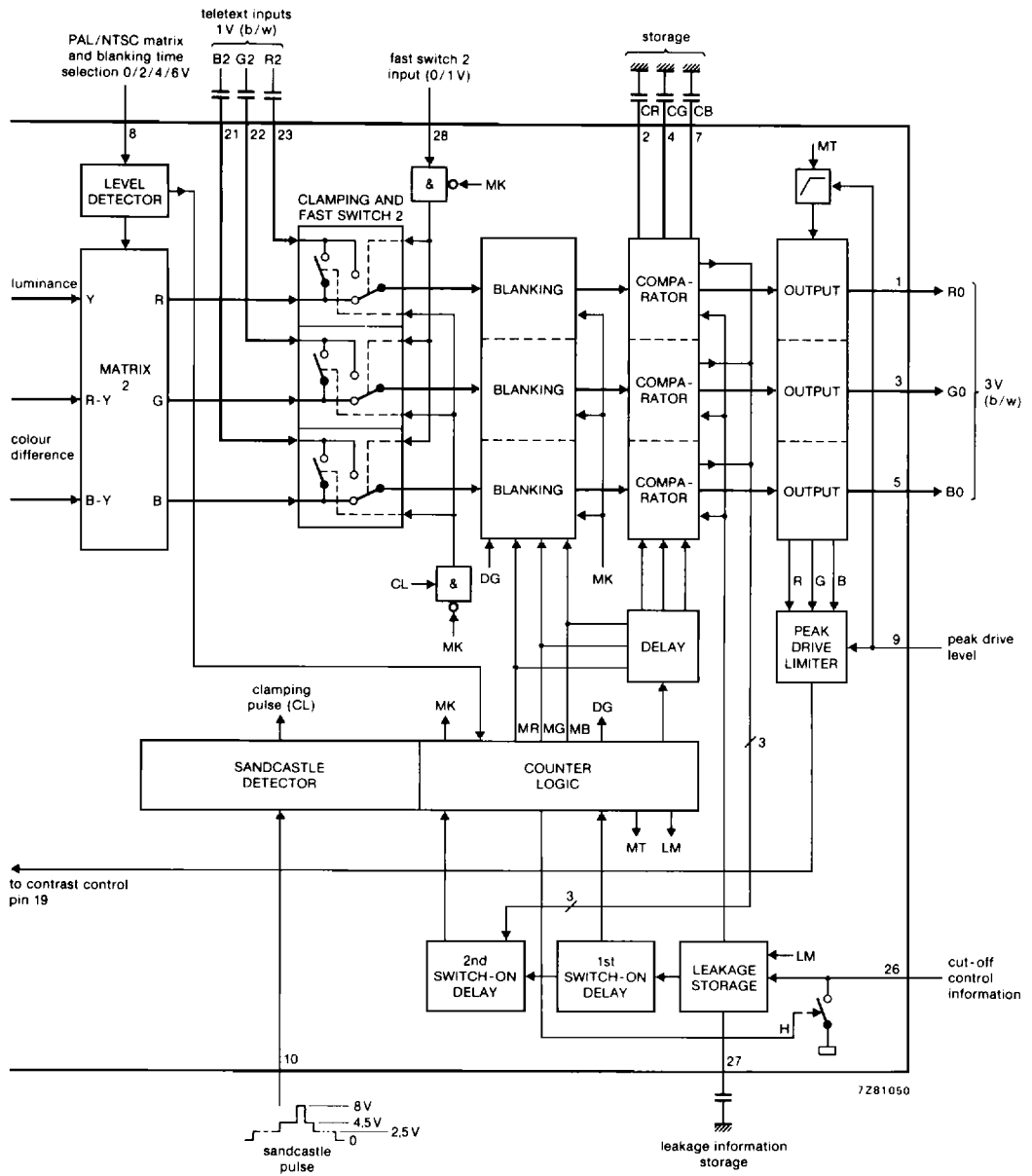

Fig. 1b Part of block diagram; continued from Fig. 1a.

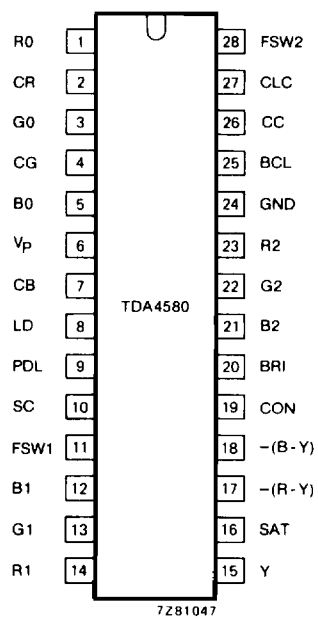

Fig. 2 Pinning diagram.

PINNING

pin no.	mnemonic	description
1	R0	Red output
2	CR	Red storage capacitor for cut-off control
3	G0	Green output
4	CG	Green storage capacitor for cut-off control
5	B0	Blue output
6	V _p	Positive supply voltage (+ 12 V)
7	CB	Blue storage capacitor for cut-off control
8	LD	PAL/NTSC matrix and blanking time level detector input
9	PDL	Peak drive limiting input
10	SC	Sandcastle pulse input
11	FSW1	Fast switch 1 for Y, CD and RGB inputs
12	B1	Blue input (external signal)
13	G1	Green input (external signal)
14	R1	Red input (external signal)
15	Y	Luminance input
16	SAT	Saturation control input
17	-(R-Y)	Colour difference input -(R-Y)
18	-(B-Y)	Colour difference input -(B-Y)
19	CON	Contrast control input
20	BRI	Brightness control input
21	B2	Teletext blue input
22	G2	Teletext green input
23	R2	Teletext red input
24	GND	Ground
25	BCL	Average beam current limiting input
26	CC	Automatic cut-off control input
27	CLC	Storage capacitor for leakage current
28	FSW2	Fast switch 2 for teletext inputs

RATINGS

Limiting values in accordance with the Absolute Maximum System (IEC 134)

Supply voltage range (pin 6)	$V_P = V_{6-24}$		0 to 13,2 V
Voltage range at pins 2, 4, 7, 9, 12, 13, 14, 15, 16, 17, 18, 19, 20, 21, 22, 23, 25, 27 to pin 24 (ground)	V_{n-24}		0 to V_P V
Voltages ranges at pins 8, 11, 28	$V_{8, 11, 28-24}$		-0,5 to V_P V
at pin 10	V_{10-24}		0 to $V_P + 0,7$ V
at pin 26	V_{26-24}		-0,7 to $V_P + 0,7$ V
Currents			
at pins 1, 3, 5 (average)	$-I_{1, 3, 5(AV)}$	max.	3 mA
at pins 1, 3, 5 (peak)	$-I_{1, 3, 5(M)}$	max.	10 mA
at pin 19 (average)	$I_{19(AV)}$	max.	5 mA
at pin 26	I_{26}	max.	1 mA
Total power dissipation	P_{tot}	max.	2 W
Storage temperature range	T_{stg}		-20 to + 150 °C
Operating ambient temperature range	T_{amb}		0 to + 70 °C

THERMAL RESISTANCE

From junction to ambient	$R_{th j-a}$	=	37 K/W
--------------------------	--------------	---	--------

CHARACTERISTICS

$V_P = 12\text{ V}$; $T_{\text{amb}} = 25\text{ }^\circ\text{C}$; measured in a circuit similar to Fig. 4 at nominal settings (saturation, contrast, brightness), no beam current or peak drive limiting; all voltages with respect to pin 24 (ground) unless otherwise specified.

parameter	symbol	min.	typ.	max.	unit
Supply (pin 6)					
Supply voltage range	$V_P = V_{6-24}$	10,8	—	13,2	V
Supply current	$I_P = I_6$	—	110	—	mA
Colour difference inputs (pins 17 and 18)					
—(R-Y) input signal at pin 17 (notes 1 and 2) (peak-to-peak value)	$V_{17-24(p-p)}$	—	1,05	—	V
—(B-Y) input signal at pin 18 (notes 1 and 2) (peak-to-peak value)	$V_{18-24(p-p)}$	—	1,33	—	V
Input current during scanning	$ I_{17, 18} $	—	—	0,3	μA
Input resistance	$R_{17, 18}$	5	—	—	$\text{M}\Omega$
Internal d.c. bias voltage during clamping time	$V_{17, 18-24}$	—	7,5	—	V
Luminance input (pin 15; note 2)					
Composite video input signal (VBS) (peak-to-peak value)	$V_{15-24(p-p)}$	—	0,45	—	V
Input current during scanning	$ I_{15} $	—	—	0,3	μA
Input resistance	R_{15}	5	—	—	$\text{M}\Omega$
Internal d.c. bias voltage during clamping time	V_{15-24}	—	7,4	—	V
Signal switch 1 input (pin 11)					
Input voltage level for insertion of Y and CD signals	V_{11-24}	—	—	0,4	V
RGB1 signals	V_{11-24}	0,9	—	3,0	V
Internal resistor to ground	R_{11}	—	10	—	$\text{k}\Omega$
RGB1 inputs (R1 pin 14, G1 pin 13, B1 pin 12; note 2) (signals controlled by saturation, contrast and brightness)					
Input signal (black to white value)	$V_{12, 13, 14-24}$	—	0,7	—	V
Input current during scanning	$ I_{12, 13, 14} $	—	—	0,3	μA
Input resistance	$R_{12, 13, 14}$	5	—	—	$\text{M}\Omega$
Internal d.c. bias voltage during clamping time	$V_{12, 13, 14-24}$	—	8,2	—	V

CHARACTERISTICS (continued)

parameter	symbol	min.	typ.	max.	unit
RGB/Y, (R-Y), (B-Y) – Matrix					
Matrixed according to the equations					
$V_{(R-Y)} = 0,7 V_R - 0,59 V_G - 0,11 V_B$					
$V_{(B-Y)} = -0,3 V_R - 0,59 V_G + 0,89 V_B$					
$V_{(Y)} = 0,3 V_R + 0,59 V_G + 0,11 V_B$					
Contrast control input (pin 19; note 3) (contrast control acts on Y and CD signals or RGB1 signals respectively)					
Maximum contrast	V_{19-24}	–	4	–	V
Nominal contrast (6 dB below max.)	V_{19-24}	–	3	–	V
Attenuation of contrast at $V_{19-24} = 2$ V (related to max.)		–	22	–	dB
Input current at $V_{19-24} = 2$ to 4 V	$-I_{19}$	–	–	3	μ A
Peak drive limiting input (pin 9; note 4)					
Internal d.c. bias voltage	V_{9-24}	–	9	–	V
Input resistance at $V_{9-24} > 9$ V	R_9	–	10	–	k Ω
Control current into contrast input (pin 19) during peak drive $V_{1, 2 \text{ or } 3-24} > V_{9-24}$	I_{19}	–	20	–	mA
Average beam current limiting input (pin 25; note 5)					
Start of contrast reduction at maximum contrast setting	V_{25-24}	–	8,5	–	V
Input range for full contrast reduction	ΔV_{25-24}	–	1,0	–	V
Input resistance at $V_{25-24} < 6$ V	R_{25}	–	2,2	–	k Ω
Saturation control input (pin 16) (saturation control acts on CD signals or RGB1 signals respectively)					
Maximum saturation	V_{16-24}	–	4	–	V
Nominal saturation (6 dB below max.)	V_{16-24}	–	3	–	V
Attenuation of saturation at $V_{16-24} = 1,8$ V (related to max. at 100 kHz)		50	–	–	dB
Input current at $V_{16-24} = 1,8$ to 4 V	I_{16}	–	–	10	μ A

parameter	symbol	min.	typ.	max.	unit
Brightness control input (pin 20; note 6 and 7)					
Control voltage range	V_{20-24}	1	—	3	V
Input current at $V_{20-24} = 1$ to 3 V	$-I_{20}$	—	—	10	μA
Control voltage for nominal brightness	V_{20-24}	—	2,2	—	V
Change of black level in the control range related to the nominal output signal (black/white) for $\Delta V_{20-24} = 1$ V		—	33	—	%
Signal switched off and black level equal to cut-off measuring level at	V_{20-24}	11,5	—	—	V
Y, (R-Y), (B-Y)/RGB – Matrix (note 8)					
PAL matrix ($V_{8-24} = < 4,5$ V)					
Matrixed according to the equation $V_{(G-Y)} = -0,51 V_{(R-Y)} - 0,19 V_{(B-Y)}$					
NTSC matrix ($V_{8-24} = > 5,5$ V)					
(Adaption for NTSC-FCC primaries, nominal hue control set on -5°)					
Matrixed according to the equation $V_{(G-Y)^*} = -0,43 V_{(R-Y)} - 0,11 V_{(B-Y)}$ $V_{(R-Y)^*} = 1,57 V_{(R-Y)} - 0,41 V_{(B-Y)}$ $V_{(B-Y)^*} = V_{(B-Y)}$					
RGB2 inputs (Teletext) (R2 pin 23, G2 pin 22, B2 pin 21; note 2)					
(RGB signals controlled by brightness control)					
Input signal for 100% output signals (black to white value)	$V_{21, 22, 23-24}$	—	1	—	V
Input current during scanning	$I_{21, 22, 23}$	—	—	0,3	μA
Input resistance	$R_{21, 22, 23}$	5	—	—	$\text{M}\Omega$
Signal switch 2 input (pin 28)					
Input voltage level for insertion of Y, CD signals or RGB1 signals respectively					
RGB signals from matrix (note 9)	V_{28-24}	—	—	0,4	V
RGB2 signals (note 9)	V_{28-24}	0,9	—	3,0	V
Internal resistor to ground	R_{28-24}	—	10	—	$\text{k}\Omega$

CHARACTERISTICS (continued)

parameter	symbol	min.	typ.	max.	unit
Automatic cut-off control input (pin 26; note 10) (leakage current measuring time and insertion of RGB cut-off measuring lines see Fig. 5; types of ultra-black level see Fig. 3)					
Allowed maximum external D.C. bias voltage	V_{26-24}	5,5	—	—	V
Voltage difference between cut-off current measurement and leakage current measurement	ΔV_{26-24}	—	0,5	—	V
Warm-up test pulse	$V_{1, 3, 5-24}$	—	V_{9-24}^*	—	V
Threshold for warm-up detector	V_{26-24}	—	8	—	V
Storage input for leakage current (pin 27)					
Internal resistance during leakage current measuring time (current limiting at $I_{27} = 0,2$ mA)	R_{27}	—	400	—	Ω
Input current except during cut-off control cycle	$I_{ 27 }$	—	—	0,5	μA
Storage inputs for automatic cut-off control (pins 2, 4, 7)					
Charge and discharge currents	$I_{ 2, 4, 7 }$	—	0,3	—	mA
Input currents of storage inputs out of control time	$I_{ 2, 4, 7 }$	—	—	0,1	μA
Switch input for PAL/NTSC matrix and vertical blanking time (pin 8; note 11)					
Switching voltage input for					
PAL matrix and vertical blanking period of					
25 lines	V_{8-24}	—	0	0,5	V
22 lines	V_{8-24}	1,5	2	2,5	V
18 lines	V_{8-24}	3,5	4	4,5	V
NTSC matrix and vertical blanking period of					
18 lines	V_{8-24}	5,5	6	12	V
Input current	I_8	—	—	50	μA

* Maximum 8 V.

parameter	symbol	min.	typ.	max.	unit
Sandcastle pulse detector (pin 10; note 12)					
The following amplitudes are required for separating the various pulses:					
horizontal and vertical blanking pulses	V_{10-24}	2,0	2,5	3,0	V
horizontal pulses for counter logic	V_{10-24}	4,0	4,5	5,0	V
clamping pulses	V_{10-24}	7,5	—	—	V
delay of leading edge of clamping pulse	t_d	—	1	—	μs
Input current at $V_{10-24} = 0$ V	$-I_{10}$	—	—	100	μA
Outputs for positive RGB signals (R0 pin 1, G0 pin 3, B0 pin 5; note 13)					
Nominal signal amplitude (black/white)	$V_{1, 3, 5-24}$	—	3	—	V
Spreads between channels		—	—	10	%
Maximum signal amplitude (black/white)	$V_{1, 3, 5-24}$	4	—	—	V
Internal current source	$I_{1, 3, 5}$	—	3	—	mA
Output resistance	$R_{1, 3, 5}$	—	160	220	Ω
Minimum output voltage	$V_{1, 3, 5-24}$	—	1	—	V
Maximum output voltage	$V_{1, 3, 5-24}$	—	10	—	V
Horizontal and vertical blanking to ultra-black level 2 related to nominal signal black level in percentage of nominal signal amplitude		45	55	—	%
Vertical blanking to ultra-black level 1 related to cut-off measuring level in percentage of nominal signal amplitude		25	35	—	%
<i>Recommendation:</i>					
Range for cut-off measuring level 1,5 to 5,0 V; nominal value at 3 V (note 14)					
Gain data (note 15)					
Frequency response of Y path (0 to 8 MHz) pins 1, 3 and 5 to pin 15	d	—	—	3	dB
Frequency response of CD path (0 to 8 MHz) pin 1 to pin 17 = pin 5 to pin 18	d	—	—	3	dB
Frequency response of RGB1 path (0 to 8 MHz) pin 1 to pin 14 = pin 3 to pin 13 = pin 5 to pin 12	d	—	—	3	dB
Frequency response of RGB2 path (0 to 10 MHz) pin 1 to pin 23 = pin 3 to pin 22 = pin 5 to pin 21	d	—	—	3	dB

Notes to the characteristics

1. The value of the colour difference input signals, $-(B-Y)$ and $-(R-Y)$, is given for saturated colour bar with 75% of maximum amplitude.
2. Capacitive coupled to a low ohmic source; recommended value 600Ω (max.).
3. At pin 19 for $V_{19,24} \leq 2,0 \text{ V}$, no further decrease of contrast is possible.
4. The peak drive limiting of output signals is achieved by contrast reduction. The limiting level of the output signals is equal to the voltage $V_{9,24}$, adjustable in the range 5 to 11 V. After exceeding the adjusted limiting level at peak drive limiter will not be active during the first line.
5. The average beam current limiting acts on contrast and at minimum contrast on brightness (the external contrast voltage at pin 19 is not affected).
6. At nominal brightness the black level at the output is $0,3 \text{ V}$ ($\hat{=}$ -10% of nominal signal amplitude) below the measuring level.
7. The internal control voltage can never be more positive than $0,7 \text{ V}$ above the internal contrast voltage.
8. Matrix equation

$V_{(R-Y)}, V_{(B-Y)}$:	output of NTSC decoder of PAL type demodulating axis and amplitudes
$V_{(G-Y)^*}, V_{(R-Y)^*}, V_{(B-Y)^*}$:	for NTSC modified CD signals; equivalent to demodulation with the following axes and amplification factors:—
$(B-Y)^*$ demodulator axis		0°
$(R-Y)^*$ demodulator axis		115° (PAL 90°)
$(R-Y)^*$ amplification factor		1,97 (PAL 1,14)
$(B-Y)^*$ amplification factor		2,03 (PAL 2,03)

$$V_{(G-Y)^*} = -0,27 V_{(R-Y)^*} - 0,22 V_{(B-Y)^*}.$$
9. During clamping time, in each channel the black level of the inserted signal is clamped on the black level of the internal signal behind the matrix (dependent on brightness control).
10. During warm-up time of the picture tube, the RGB outputs (pins 1, 3 and 5) are blanked to minimum output voltage. An inserted white pulse during the vertical flyback is used for beam current detection. If the beam current exceeds the threshold of the warm-up detector at pin 26, the cut-off current control starts operating, but the video signal is still blanked. After run-in of the cut-off current control loop, the video signal will be released.

The first measuring pulse occurs in the first complete line after the end of the vertical part of the sandcastle pulse. The absolute minimum vertical part must contain 9 line-pulses. The cycle time of the counter is 63 lines. When the vertical pulse is longer than 61 lines, the IC is reset to the switch-on condition. In this event the video signal is blanked and the RGB-outputs are blanked to minimum output voltage as during warm-up time.

During leakage current measurement, all three channels are blanked to ultra-black level 1. With the measuring level only in the controlled channel, the other two channels are blanked to ultra-black level 1. The brightness control shifts both the signal black level and the ultra-black level 2. The brightness control is disabled from line 4 to the end of the last measuring line (see Fig. 3).

With the most adverse conditions (maximum brightness and minimum black level 2) the blanking level is located 30% of nominal signal amplitude below the cut-off measuring level.

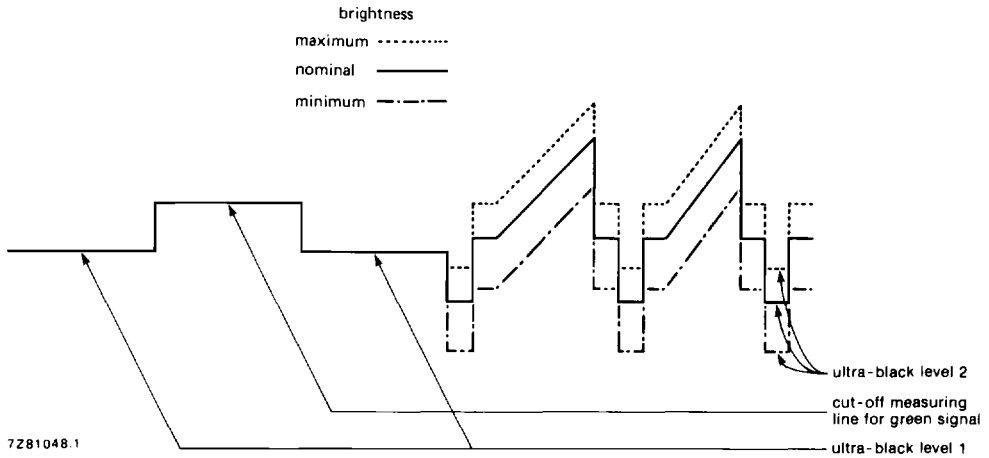
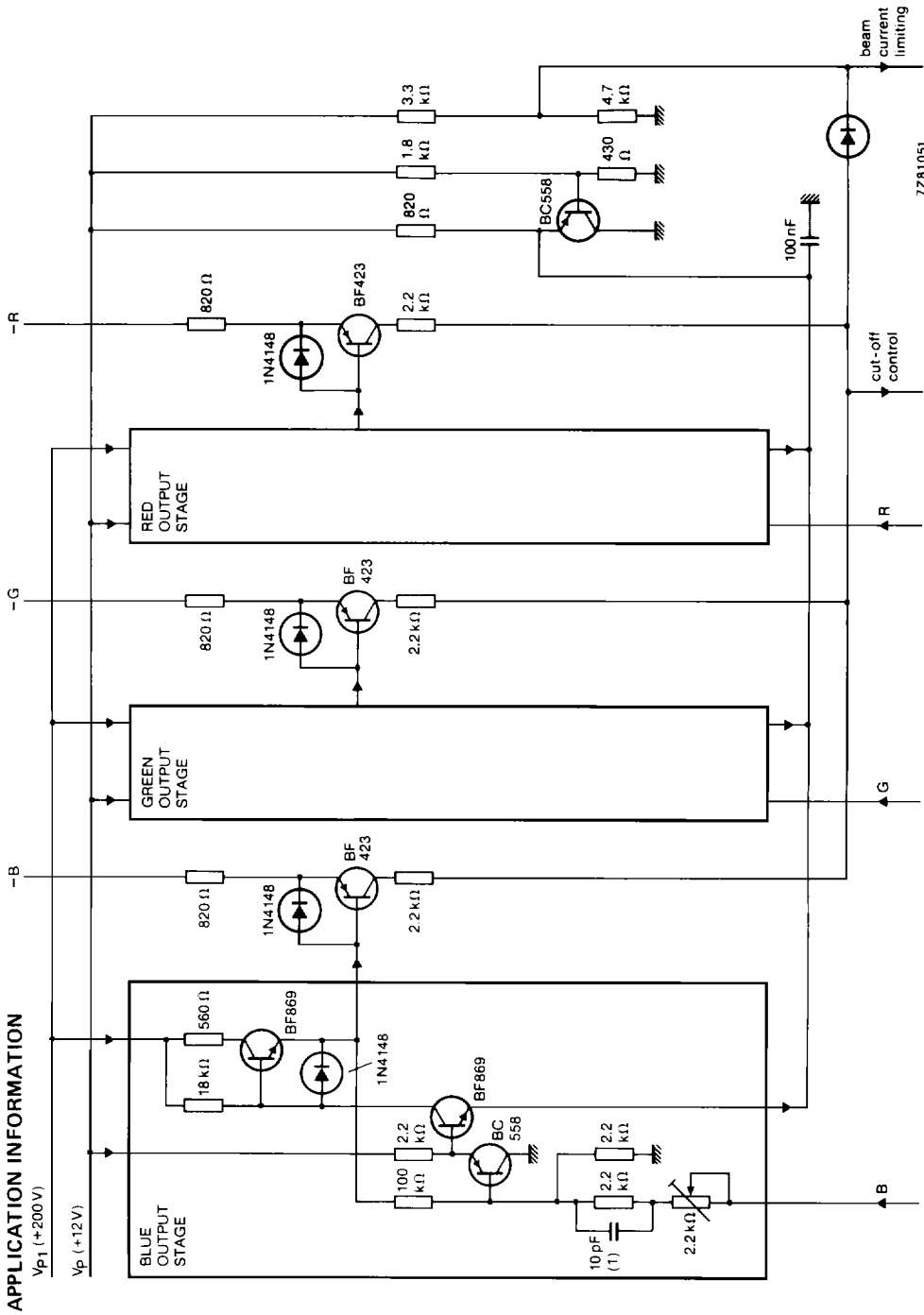

Fig. 3 Types of ultra-black levels.

11. The given blanking times are valid for the vertical part of the sandcastle pulse of 9 to 15 lines. If the vertical part is longer and the cut-off lines are outside the vertical blanking period of 18, 22 or 25 lines respectively, the blanking of the signal ends with the end of last of the three cut-off measuring pulses as shown in Fig. 5.
12. The sandcastle pulse is compared with three internal thresholds (proportional to V_p) to separate the various pulses. The internal pulses are generated when the input pulse at pin 10 exceeds the thresholds. The thresholds are for:
 - Horizontal and vertical blanking $V_{10-24} = 1,5 \text{ V}$
 - Horizontal pulse $V_{10-24} = 3,5 \text{ V}$
 - Clamping pulse $V_{10-24} = 7,0 \text{ V}$
13. The outputs at pins 1, 3 and 5 are emitter followers with current sources and emitter protection resistors.
14. The value of the cut-off control range for the positive RGB output signals is given for a nominal output signal. If the signal amplitude is reduced, the cut-off range can be increased.
15. The gain data is given for a nominal setting of the contrast and saturation controls, measured without load at the RGB outputs (pins 1, 3 and 5).



(1) Capacitor value depends on circuit layout.

Fig. 4a Part of typical application circuit diagram using the TDA4580; continued in Fig. 4b.

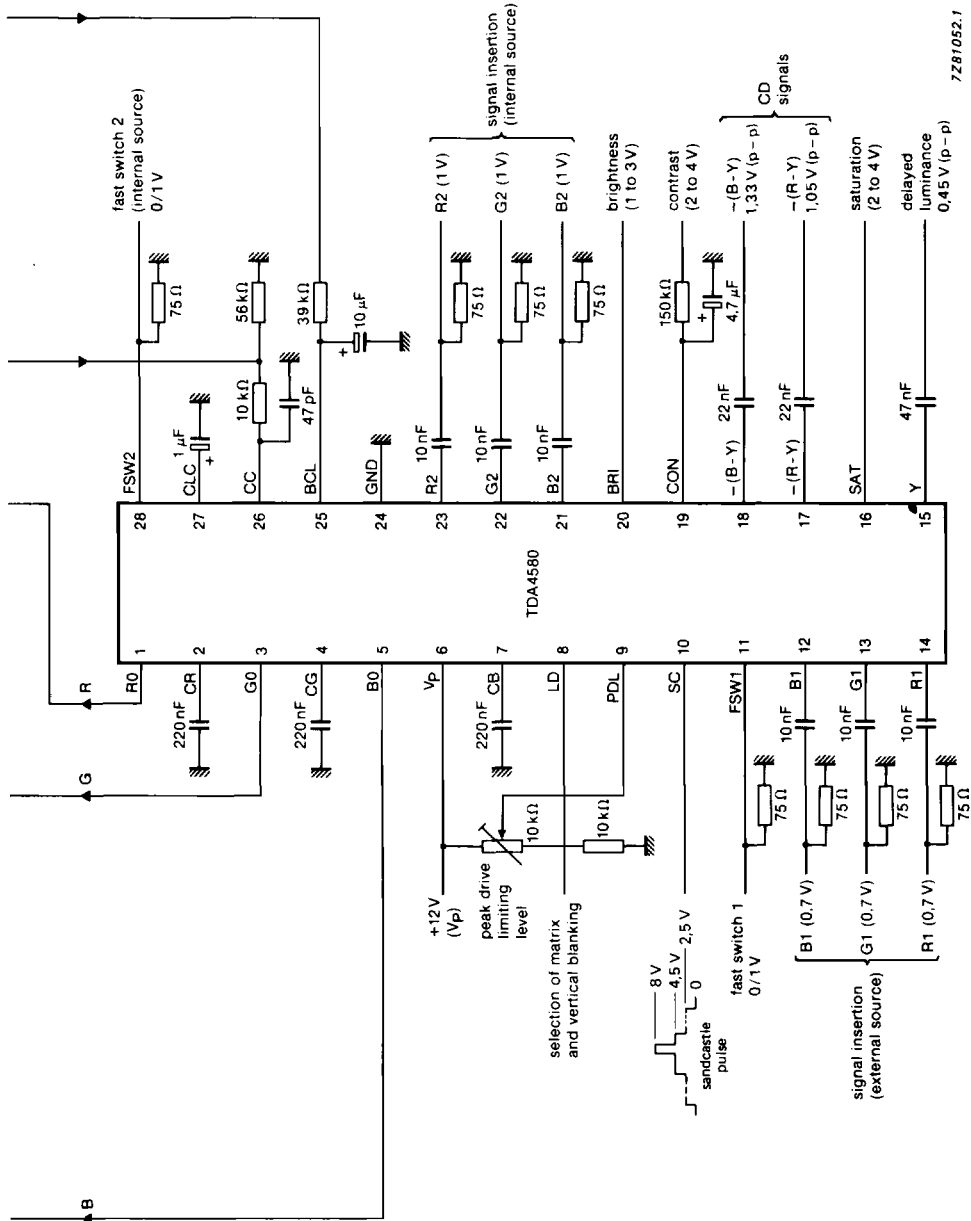

7281052.1

Fig. 4b Part of typical application circuit diagram using the TDA4580; continued from Fig. 4a.

APPLICATION INFORMATION (continued)

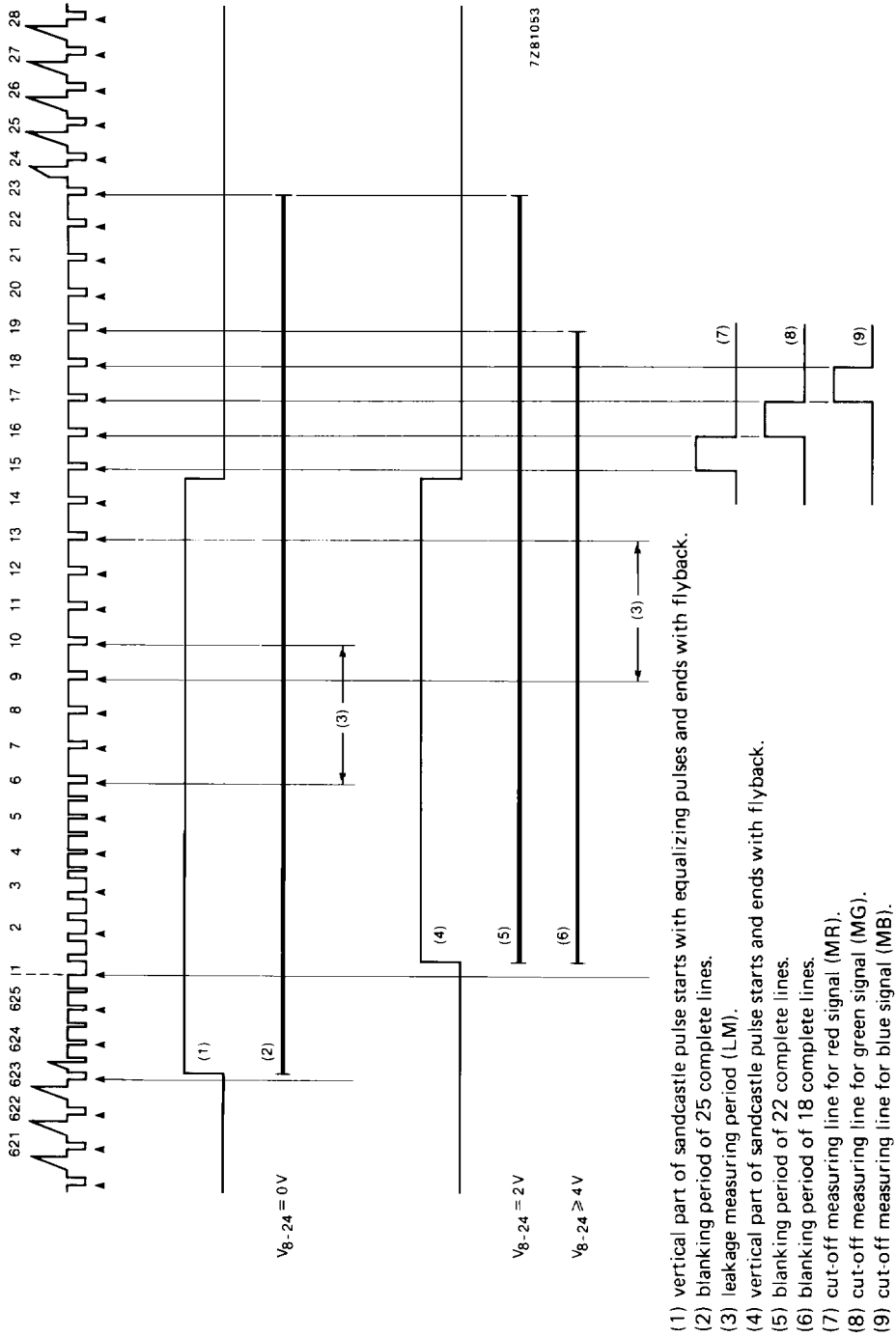

- (1) vertical part of sandcastle pulse starts with equalizing pulses and ends with flyback.
- (2) blanking period of 25 complete lines.
- (3) leakage measuring period (LM).
- (4) vertical part of sandcastle pulse starts and ends with flyback.
- (5) blanking period of 22 complete lines.
- (6) blanking period of 18 complete lines.
- (7) cut-off measuring line for red signal (MR).
- (8) cut-off measuring line for green signal (MG).
- (9) cut-off measuring line for blue signal (MB).

Fig. 5 Blanking and measuring lines.