

# DATA SHEET

## SURFACE-MOUNT CERAMIC MULTILAYER CAPACITORS

High-Voltage

NP0/X7R

500 V TO 3 KV

0.47 pF to 33 nF

RoHS compliant & Halogen Free



SCOPE

This specification describes High-Voltage NP0/X7R series chip capacitors with lead-free terminations.

APPLICATIONS

PCs, Hard disk, Game PCs  
Power supplies  
LCD panel  
ADSL, Modem

FEATURES

RoHS compliant  
Halogen Free compliant  
MSL class MSL I  
Soldering is compliant with J-STD-020D

ORDERING INFORMATION-GLOBAL PART NUMBER, PHYCOMP

CTC & I2NC

All part numbers are identified by the series, size, tolerance, TC material, packing style, voltage, process code, termination and capacitance value.

**YAGEO BRAND ordering code**

**GLOBAL PART NUMBER (PREFERRED)**

**CC** XXXX X X XXX X X X XXX  
(1) (2) (3) (4) (5) (6) (7) (8)

**(1) SIZE – INCH BASED (METRIC)**

0805 (2012) / 1206 (3216) / 1210 (3225) / 1808 (4520) / 1812 (4532) / 2220 (5750)

**(2) TOLERANCE**

C = ±0.25 pF  
D = ±0.5 pF  
G = ±2%  
J = ±5%  
K = ±10%  
M = ±20%

**(3) PACKING STYLE**

R = Paper/PE taping reel; Reel 7 inch  
K = Blister taping reel; Reel 7 inch  
P = Paper/PE taping reel; Reel 13 inch  
F = Blister taping reel; Reel 13 inch

**(4) TC MATERIAL**

NP0 = NP0  
X7R = X7R

**(5) RATED VOLTAGE**

B = 500V      D = 2 KV  
Z = 630V      S = 2.5KV  
C = 1KV      E = 3 KV

**(6) CONTROL CODE**

A: Anti-arc coating  
B: Standard Type

**(7) PROCESS**

N = NP0  
B = X7R

**(8) CAPACITANCE VALUE**

2 significant digits+number of zeros  
The 3rd digit signifies the multiplying factor, and letter R is decimal point  
Example: 121 = 12 × 101 = 120 pF

**CONSTRUCTION**

The capacitor consists of a rectangular block of ceramic dielectric in which a number of interleaved metal electrodes are contained. This structure gives rise to a high capacitance per unit volume.

The inner electrodes are connected to the two end terminations and finally covered with a layer of plated tin (NiSn). The terminations are lead-free. A cross section of the structure is shown in Fig.1.

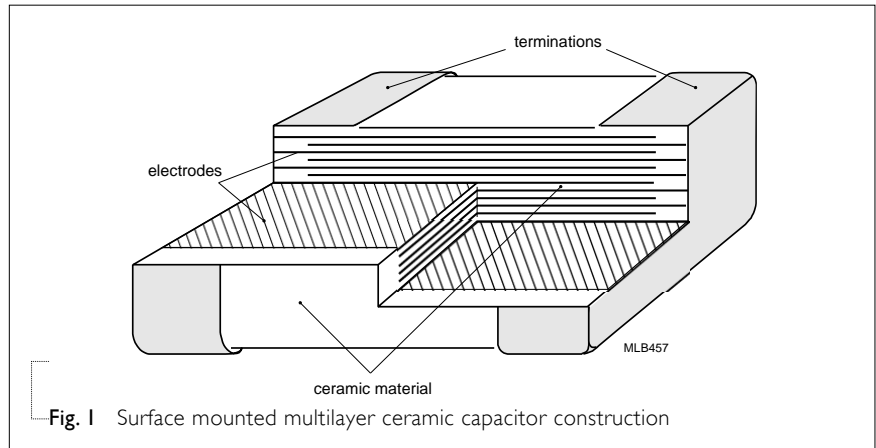

**DIMENSION**

Table I For outlines see fig.2

TYPE	L <sub>1</sub> (mm)	W (mm)	T (MM)	L <sub>2</sub> / L <sub>3</sub> (mm)		L <sub>4</sub> (mm)
				min.	max.	min.
0805	2.0 ±0.10	1.25 ±0.10	0.60 ±0.10	0.25	0.75	0.70
	2.0 ±0.20	1.25 ±0.20	1.25 ±0.20			
	3.2 ±0.15	1.60 ±0.15	0.60 ±0.10			
1206	3.2 ±0.30	1.60 ±0.20	0.85 ±0.10	0.25	0.75	1.40
			1.25 ±0.20			
			1.60 ±0.20			
1210	3.2 ±0.30	2.50 ±0.20	0.85 ±0.10	0.25	0.75	1.40
			1.25 ±0.20			
			1.60 ±0.20			
1808	4.5 ±0.40	2.00 ±0.30	1.25 ±0.20	0.25	0.75	2.20
			1.35 ±0.15			
			1.60 ±0.20			
			2.00 ±0.20			
1812	4.5 ±0.40	3.20 ±0.20	0.85 ±0.10	0.25	0.75	2.20
			1.25 ±0.20			
			1.35 ±0.15			
			1.60 ±0.20			
2220	5.7 ±0.40	5.0 ±0.3	2.00 ±0.20	0.25	0.75	3.40
			2.00 ±0.20			

**OUTLINES**

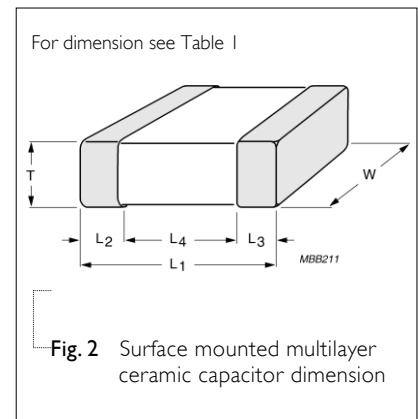

**CAPACITANCE RANGE & THICKNESS FOR NP0**

**Table 2** Sizes from 0805 to 1210

CAP.	0805			1206				1210				
	500 V	630 V	1 KV	500 V	630 V	1 KV	2 KV	3 KV	500 V	630 V	1 KV	2 KV
1.0 pF												
1.2 pF												
1.5 pF												
1.8 pF												
2.2 pF												
2.7 pF												
3.3 pF						0.85±0.1						
3.9 pF												
4.7 pF												
5.6 pF												
6.8 pF												
8.2 pF												
10 pF						0.85±0.1 1.25±0.2						
12 pF												
15 pF												
18 pF												
22 pF			0.85±0.1						1.25±0.2			
27 pF												
33 pF												
39 pF				0.6±0.1	1.25±0.2		1.25±0.2					
47 pF						1.25±0.2						
56 pF												
68 pF			1.25±0.2									
82 pF									1.25±0.2	1.25±0.2	1.25±0.2	1.25±0.2
100 pF												
120 pF												
150 pF												
180 pF												

**NOTE**

1. Values in shaded cells indicate thickness class in mm
2. Capacitance value of non E-12 series is on request

**CAPACITANCE RANGE & THICKNESS FOR NP0**

Table 3 Sizes from 0805 to 1210 (continued)

CAP.	0805			1206					1210			
	500 V	630 V	1 KV	500 V	630 V	1 KV	2 KV	3 KV	500 V	630 V	1 KV	2 KV
220 pF							1.25±0.2					1.25±0.2
270 pF												
330 pF	0.85±0.1	0.85±0.1										
390 pF				0.6±0.1								
470 pF						1.25±0.2				1.25±0.2	1.25±0.2	
560 pF					1.25±0.2				1.25±0.2			
680 pF												
820 pF	1.25±0.2	1.25±0.2										
1.0 nF												
1.2 nF				0.85±0.1								
1.5 nF												

**NOTE**

- 1. Values in shaded cells indicate thickness class in mm
- 2. Capacitance value of non E-12 series is on request

**CAPACITANCE RANGE & THICKNESS FOR NP0**

Table 4 Sizes from 1808 to 1812

CAP.	1808			1812					
	1 KV	2 KV	3 KV	500 V	630 V	1 KV	2 KV	3 KV	
0.47 pF									
0.56 pF									
0.68 pF									
0.82 pF									
1.0 pF									
1.2 pF									
1.5 pF									
1.8 pF									
2.2 pF									
2.7 pF									
3.3 pF									
3.9 pF									
4.7 pF									
5.6 pF									
6.8 pF									
8.2 pF									
10 pF									
12 pF									
15 pF									
18 pF									
22 pF									
27 pF									
33 pF									
39 pF									
47 pF									
56 pF									
68 pF									
82 pF	1.25±0.2	1.25±0.2							
100 pF				1.25±0.2	1.25±0.2				
120 pF									
150 pF									
180 pF									
			1.6±0.2			1.25±0.2	1.25±0.2	1.25±0.2	

**NOTE**

1. Values in shaded cells indicate thickness class in mm
2. Capacitance value of non E-12 series is on request

**CAPACITANCE RANGE & THICKNESS FOR NP0**

Table 5 Sizes from 1808 to 1812 (continued)

CAP.	1812			1812			1812		
	1 KV	2 KV	3 KV	500 V	630 V	1 KV	2 KV	3 KV	
220 pF								1.25±0.2	
270 pF									
330 pF									
390 pF	1.25±0.2	1.25±0.2							
470 pF							1.25±0.2		
560 pF				1.25±0.2	1.25±0.2	1.25±0.2			
680 pF									
820 pF									
1.0 nF									
1.2 nF									
1.5 nF									

**NOTE**

1. Values in shaded cells indicate thickness class in mm
2. Capacitance value of non E-12 series is on request

**CAPACITANCE RANGE & THICKNESS FOR X7R**

Table 6 Sizes from 0805 to 1210

CAP.	0805			1206				1210				
	500 V	630 V	1 KV	500 V	630 V	1 KV	2 KV	2.5KV	500 V	630 V	1 KV	2 KV
100 pF												
150 pF												
220 pF												
330 pF			0.85±0.1									
470 pF												1.25±0.2
680 pF							1.25±0.2					
1.0 nF	0.85±0.1	0.85±0.1						1.6±0.2				
1.5 nF						1.25±0.2						
2.2 nF			1.25±0.2	1.25±0.2	1.25±0.2						1.25±0.2	1.60±0.2
3.3 nF												
4.7 nF												
6.8 nF										1.25±0.2		
10 nF		1.25±0.2							1.25±0.2			
15 nF	1.25±0.2											
22 nF											1.6±0.2	1.6±0.2
33 nF				1.60±0.2	1.60±0.2							
47 nF										2.0±0.2		
68 nF												
100 nF									2.0±0.2			

**NOTE**

1. Values in shaded cells indicate thickness class in mm
2. Capacitance value of non E-6 series is on request
3. For products with 5% tolerance, please contact local sales force before ordering



**CAPACITANCE RANGE & THICKNESS FOR X7R**

Table 7 Sizes from 1808 to 1812

CAP.	1808			1812			2020		
	1 KV	2 KV	3 KV	500 V	630 V	1 KV	2 KV	3 KV	630 V
100 pF									
150 pF									
220 pF									
330 pF			1.6±0.2						
470 pF									
680 pF		1.35±0.15							
1.0 nF			2.0±0.2					1.6±0.2	
1.5 nF	1.35±0.15								
2.2 nF		1.6±0.2					1.35±0.15		
3.3 nF									
4.7 nF					1.35±0.2	1.35±0.15			
6.8 nF				1.25±0.2					
10 nF	1.6±0.2								
15 nF									
22 nF									
33 nF						1.6±0.2			
47 nF					1.6±0.2				
68 nF									
100 nF				1.6±0.2	2.0±0.2				
150 nF									2.0±0.2
220 nF									
330 nF									
470 nF									
680 nF									
1 μF									

**NOTE**

1. Values in shaded cells indicate thickness class in mm
2. Capacitance value of non E-6 series is on request
3. For products with 5% tolerance, please contact local sales force before ordering

**THICKNESS CLASSES AND PACKING QUANTITY**

Table 8

SIZE CODE	THICKNESS CLASSIFICATION	PACKING CODE.		TAPE WIDTH QUANTITY PER REEL	Ø180 MM / 7 INCH		Ø330 MM / 13 INCH		QUANTITY PER BULK CASE
		7 INCH	13 INCH		Paper	Blister	Paper	Blister	
0805	0.6 ±0.1 mm	R	P	8 mm	4,000	---	20,000	---	10,000
	0.85 ±0.1 mm	R	P	8 mm	4,000	---	15,000	---	8,000
	1.00 ±0.1 mm	K	F	8 mm	---	3,000	---	10,000	---
	1.25 ±0.2 mm	K	F	8 mm	---	3,000	---	10,000	5,000
1206	0.6 ±0.1 mm	R	P	8 mm	4,000	---	20,000	---	---
	0.85 ±0.1 mm	R	P	8 mm	4,000	---	15,000	---	---
	1.00 / 1.15 ±0.1 mm	K	F	8 mm	---	3,000	---	10,000	---
	1.25 ±0.2 mm	K	F	8 mm	---	3,000	---	10,000	---
	1.6 ±0.2 mm	K	F	8 mm	---	2,000	---	8,000	---
1210	0.85 ±0.1 mm	K	F	8 mm	---	4,000	---	10,000	---
	1.15 ±0.1 mm	K	F	8 mm	---	3,000	---	10,000	---
	1.15 ±0.15 mm	K	F	8 mm	---	3,000	---	10,000	---
	1.25 ±0.2 mm	K		8 mm	---	3,000	---	---	---
	1.5 ±0.1 mm	K		8 mm	---	2,000	---	---	---
	1.6 ±0.2 mm	K		8 mm	---	2,000	---	---	---
	2.0 ±0.2 mm	K		8 mm	---	2,000 1,000	---	---	---
1808	1.15 ±0.15 mm	K		12 mm	---	3,000	---	---	---
	1.25 ±0.2 mm	K		12 mm	---	3,000	---	---	---
	1.35 ±0.15 mm	K		12 mm	---	2,000	---	---	---
	1.5 ±0.1 mm	K		12 mm	---	2,000	---	---	---
	1.6 ±0.2 mm	K		12 mm	---	2,000	---	---	---
	2.0 ±0.2 mm	K		12 mm	---	2,000	---	---	---
1812	0.6 / 0.85 ±0.1 mm	K		12 mm	---	2,000	---	---	---
	1.15 ±0.1 mm	K		12 mm	---	1,000	---	---	---
	1.15 ±0.15 mm	K		12 mm	---	1,000	---	---	---
	1.25 ±0.2 mm	K		12 mm	---	1,000	---	---	---
	1.35 ±0.15 mm	K		12 mm	---	1,000	---	---	---
	1.5 ±0.1 mm	K		12 mm	---	1,000	---	---	---
	1.6 ±0.2 mm	K		12 mm	---	1,000	---	---	---
	2.0 ±0.2 mm	K		12 mm	---	1,000	---	---	---
2.5 ±0.2 mm	K		12 mm	---	500	---	---	---	
2220	2.0 ±0.2 mm	K		12 mm	---	1000	---	---	---

**PAPER/PE TAPE SPECIFICATION**

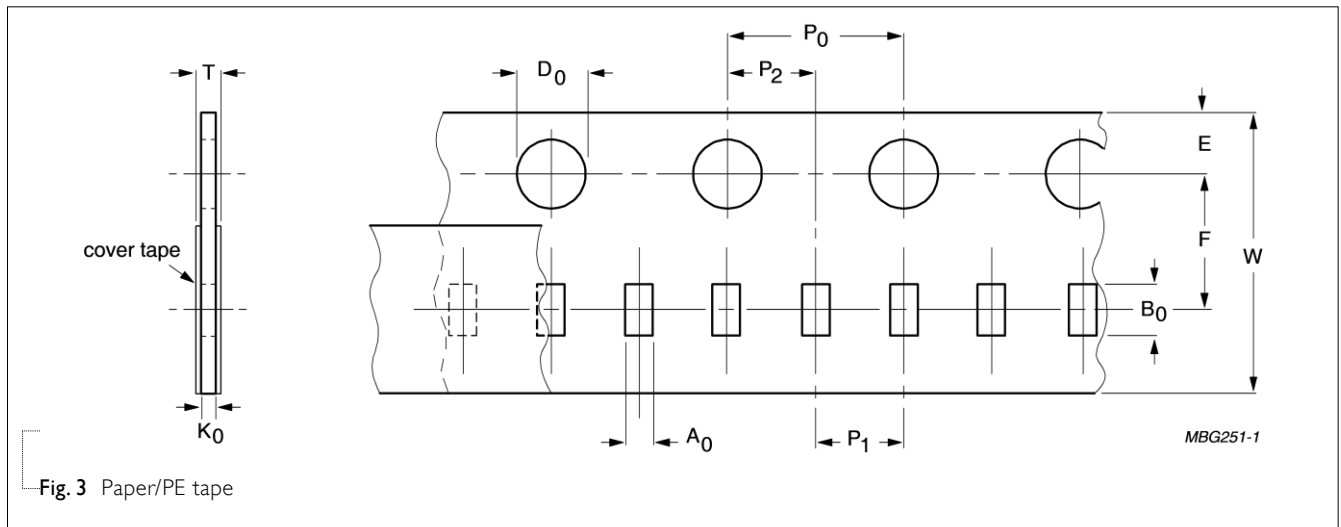

Fig. 3 Paper/PE tape

Table 9 Dimensions of paper/PE tape for relevant chip size; see Fig.3

SIZE	SYMBOL											Unit: mm
CODE	A <sub>0</sub>	B <sub>0</sub>	W	E	F	P <sub>0</sub> <sup>(1)</sup>	P <sub>1</sub>	P <sub>2</sub>	ØD <sub>0</sub>	K <sub>0</sub>	T	
0201	0.39 ± 0.06	0.70 ± 0.06	8.0 ± 0.20	1.75 ± 0.1	3.50 ± 0.05	4.0 ± 0.05	2.0 ± 0.05	2.0 ± 0.05	1.55 ± 0.03	0.38 ± 0.05	(0.47 / 0.55)±0.10	
0402	0.70 ± 0.15	1.21 ± 0.12	8.0 ± 0.20	1.75 ± 0.1	3.50 ± 0.05	4.0 ± 0.05	2.0 ± 0.05	2.0 ± 0.05	1.50 +0.1 /-0	(0.75 / 0.60)±0.10	(0.85 / 0.70)±0.10	
0603	1.05 ± 0.14	1.86 ± 0.13	8.0 ± 0.20	1.75 ± 0.1	3.50 ± 0.05	4.0 ± 0.10	4.0 ± 0.10	2.0 ± 0.05	1.50 +0.1 /-0	(1.05 / 0.95 / 0.75)±0.10	(1.15 / 1.05 / 0.85)±0.10	
0805	1.50 ± 0.15	2.26 ± 0.20	8.0 ± 0.20	1.75 ± 0.1	3.50 ± 0.05	4.0 ± 0.10	4.0 ± 0.10	2.0 ± 0.05	1.50 +0.1 /-0	(1.05 / 0.95 / 0.75)±0.10	(1.15 / 1.05 / 0.85)±0.10	
1206	1.90 ± 0.15	3.50 ± 0.20	8.0 ± 0.20	1.75 ± 0.1	3.50 ± 0.05	4.0 ± 0.10	4.0 ± 0.10	2.0 ± 0.05	1.50 +0.1 /-0	(0.95 / 0.75)±0.10	(1.05 / 0.85)±0.10	

**NOTE**

1. P<sub>0</sub> pitch tolerance over any 10 pitches is ±0.2 mm

**BLISTER TAPE SPECIFICATION**

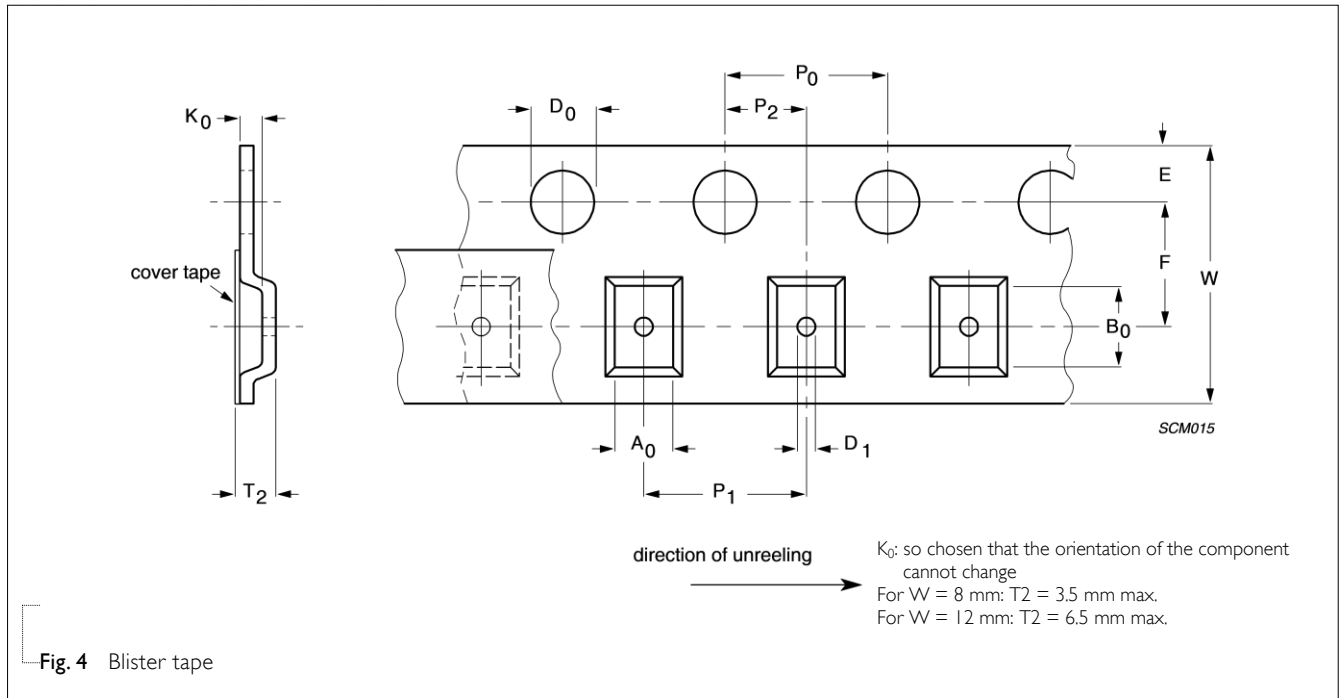

Fig. 4 Blister tape

Table 10 Dimensions of blister tape for relevant chip size; see Fig.4

SIZE CODE	SYMBOL												Unit: mm			
	A <sub>0</sub>		B <sub>0</sub>		K <sub>0</sub>		W	E	F	ØD <sub>0</sub>	ØD <sub>1</sub>	P <sub>0</sub> <sup>(2)</sup>	P <sub>1</sub>	P <sub>2</sub>	T <sub>2</sub>	
	Min.	Max.	Min.	Max.	Min.	Max.					Min.				Min.	Max.
0805	1.29	1.65	2.09	2.60	1.25	1.62	8.1 ±0.20	1.75 ±0.1	3.5 ±0.05	1.5 +0.1/-0.0	1 +0.1/-0.0	4.0 ±0.10	4.0 ±0.10	2.0 ±0.05	1.30	1.67
1206	1.65	2.12	3.30	3.75	1.22	2.15	8.1 ±0.20	1.75 ±0.1	3.5 ±0.05	1.5 +0.1/-0.0	1 +0.1/-0.0	4.0 ±0.10	4.0 ±0.10	2.0 ±0.05	1.27	2.20
1210	2.55	3.02	3.31	3.88	0.97	2.92	8.1 ±0.20	1.75 ±0.1	3.5 ±0.05	1.5 +0.1/-0.0	1 +0.1/-0.0	4.0 ±0.10	4.0 ±0.10	2.0 ±0.05	1.02	2.97
1808	2.05	2.55	4.80	5.45	1.30	2.45	12.1 ±0.20	1.75 ±0.1	5.5 ±0.05	1.5 +0.1/-0.0	1.5 +0.1/-0.0	4.0 ±0.10	4.0 ±0.10	2.0 ±0.05	1.35	2.50
1812	3.35	3.75	4.70	5.33	0.70	2.40	12.1 ±0.20	1.75 ±0.1	5.5 ±0.05	1.5 +0.1/-0.0	1.5 +0.1/-0.0	4.0 ±0.10	8.0 ±0.10	2.0 ±0.05	0.75	2.45
2220	5.12	5.32	5.84	6.04	1.28	1.48	12.0 ±0.20	1.75 ±0.1	5.5 ±0.05	1.5 +0.1/-0.0	1.5 +0.1/-0.0	4.0 ±0.10	8.0 ±0.10	2.0 ±0.05	1.33	1.53

**NOTE**

1. Typical capacitor displacement in pocket
2. P<sub>0</sub> pitch tolerance over any 10 pitches is ±0.2 mm

**REEL SPECIFICATION**

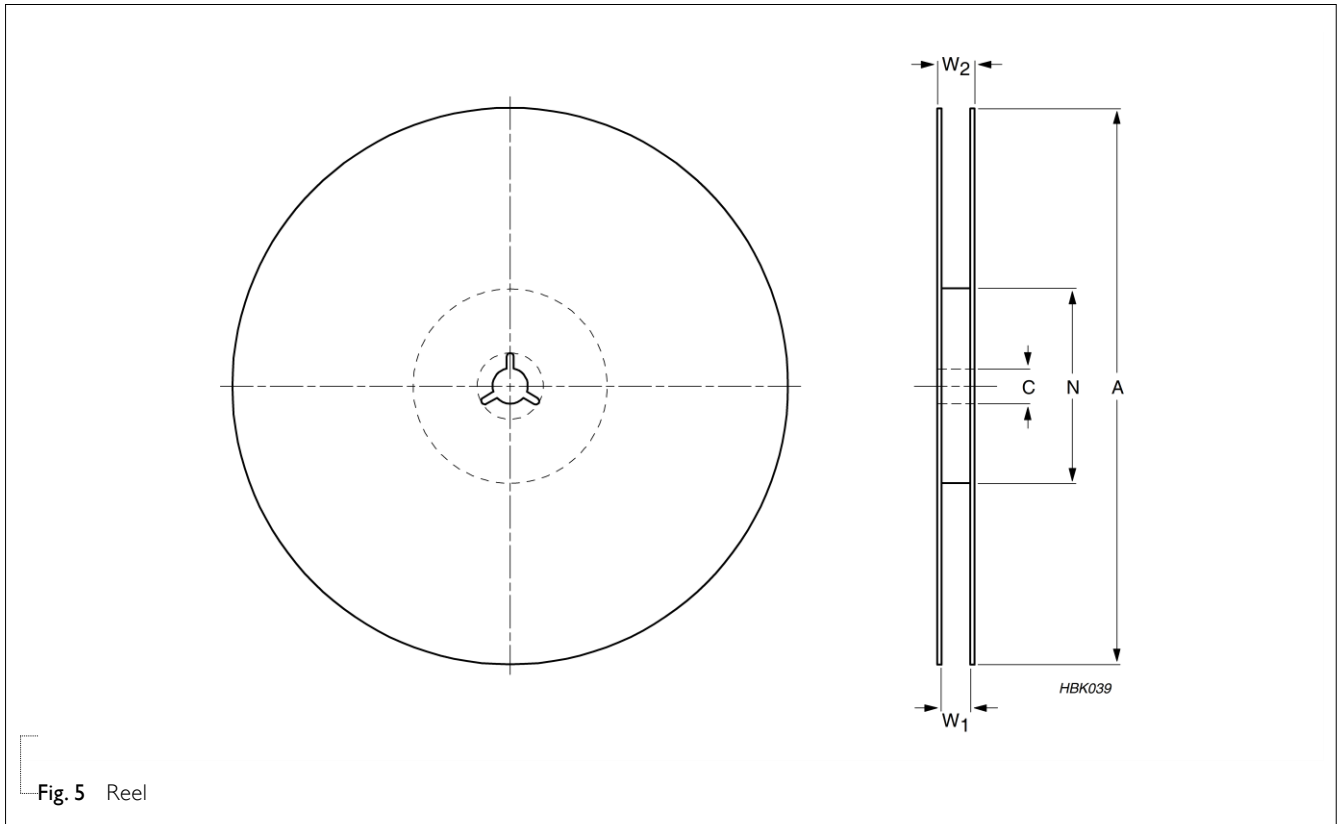

Fig. 5 Reel

Table I Reel dimensions; see Fig.5

TAPE WIDTH	SYMBOL					Unit: mm
	A	N	C	$W_1$	$W_{2max.}$	
8 (Ø178 mm/7")	178 ±1.0	60 ±1.0	13 +0.50/-0.20	9.4 ±1.5	14.4	
8 (Ø330 mm/13")	330 ±1.0	100 ±1.0	13 +0.50/-0.20	9.0 ±0.2	14.4	
12 (Ø178 mm/7")	178 ±1.0	60 ±1.0	13 +0.50/-0.20	13.4 ±1.5	18.4	

**PROPERTIES OF REEL**

Material: polystyrene

Surface resistance:  $<10^{10} \text{ } \Omega/\text{sq.}$

ELECTRICAL CHARACTERISTICS

**NP0/X7R DIELECTRIC CAPACITORS; NISN TERMINATIONS**

Unless otherwise stated all electrical values apply at an ambient temperature of 20±1 °C, an atmospheric pressure of 86 to 106 kPa, and a relative humidity of 63 to 67%.

Table 12

DESCRIPTION		VALUE
Capacitance range		0.47 pF to 33 nF
Capacitance tolerance		
NP0	C < 10 pF	±0.25 pF, ±0.5 pF
	C ≥ 10 pF	±2%, ±5%
X7R		±5% <sup>(1)</sup> , ±10%
Dissipation factor (D.F.)		
NP0	C < 30 pF	≤ 1 / ( 400 + 20C )
	C ≥ 30 pF	≤ 0.1 %
X7R		≤ 2.5 %
Insulation resistance after 1 minute at U <sub>r</sub> (DC)		R <sub>ins</sub> ≥ 10 GΩ or R <sub>ins</sub> × C ≥ 500 seconds whichever is less R <sub>ins</sub> × C ≥ 100 Ω.F <sup>(2)</sup>
Maximum capacitance change as a function of temperature (temperature characteristic/coefficient):		
NP0		±30 ppm/°C
X7R		±15%
Operating temperature range:		
NP0/X7R		-55 °C to +125 °C

**NOTE**

- ±5% tolerance of capacitance value isn't available for X7R full product range, please contact local sales force before ordering
- X7R/0805/≥3.9nF  
X7R/1206/≥12nF  
X7R/1210/≥12nF  
X7R/1808/≥18nF  
X7R/1812/≥27nF  
X7R/2220/≥150nF

**HIGH-VOLTAGE NP0**

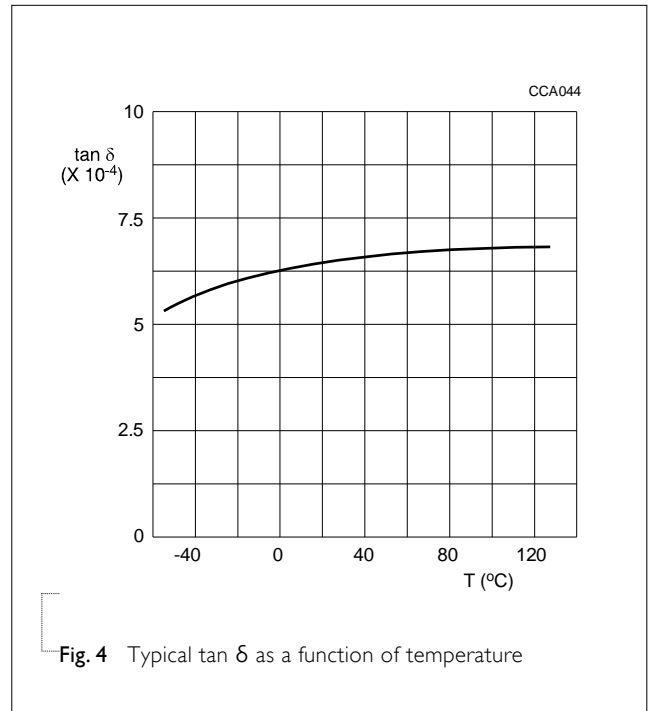
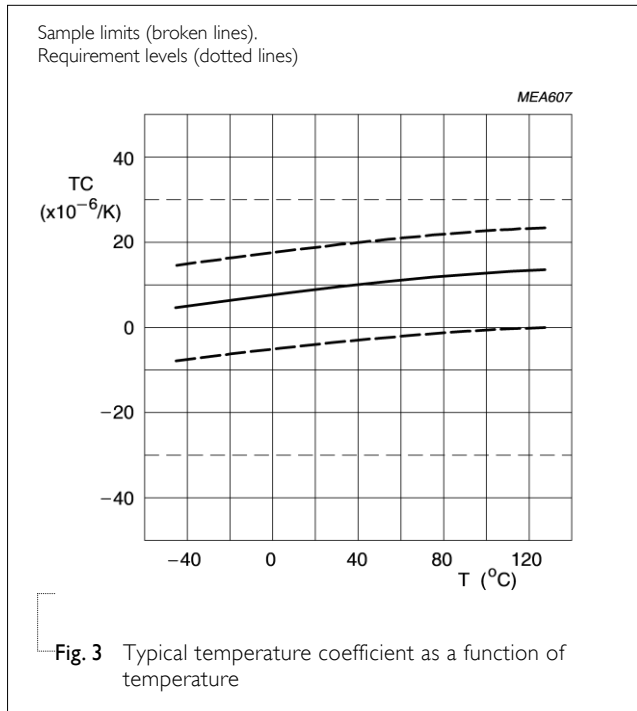

**HIGH-VOLTAGE X7R**

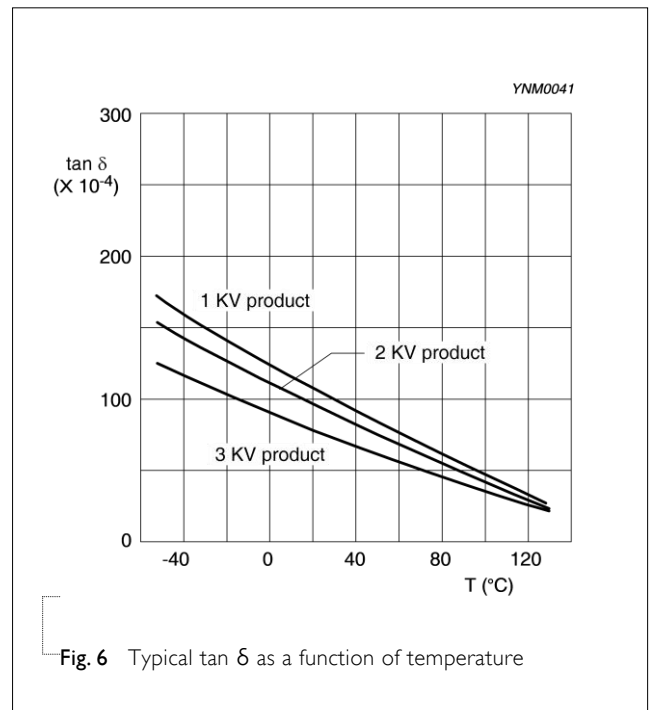
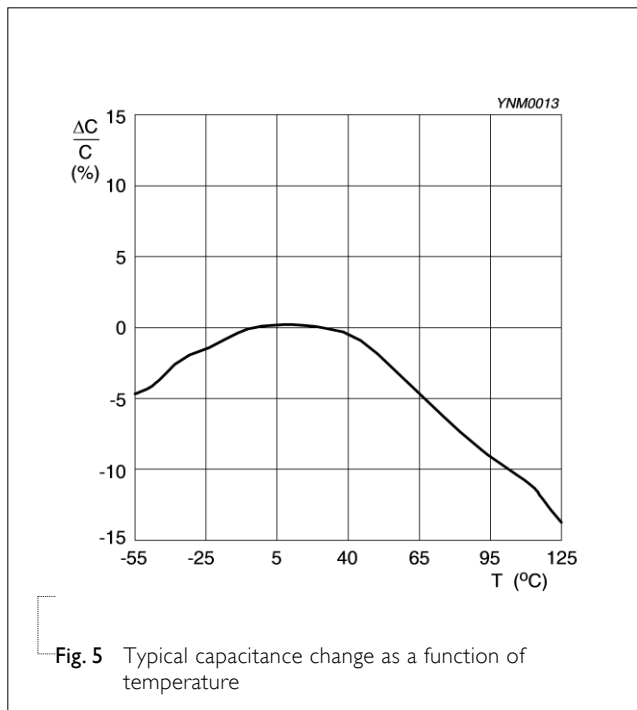

**SOLDERING RECOMMENDATION**

Table 13

SOLDERING METHOD	SIZE	0402	0603	0805	1206	≥ 1210
Reflow	Reflow only		≥ 1.0 μF	≥ 2.2 μF	≥ 4.7 μF	Reflow only
Reflow/Wave	---		< 1.0 μF	< 2.2 μF	< 4.7 μF	---

**TESTS AND REQUIREMENTS**

Table 14 Test procedures and requirements

TEST	TEST METHOD	PROCEDURE	REQUIREMENTS
Mounting	IEC 60384-21/22 4.3	The capacitors may be mounted on printed-circuit boards or ceramic substrates	No visible damage
Visual Inspection and Dimension Check	4.4	Any applicable method using × 10 magnification	In accordance with specification
Capacitance	4.5.1	NP0: f = 1 MHz for C ≤ 1 nF, measuring at voltage 1 V <sub>rms</sub> at 20 °C f = 1 KHz for C > 1 nF, measuring at voltage 1 V <sub>rms</sub> at 20 °C X7R: f = 1 KHz for C ≤ 10 μF, measuring at voltage 1 V <sub>rms</sub> at 20 °C	Within specified tolerance
Dissipation Factor (D.F.)	4.5.2	NP0: f = 1 MHz for C ≤ 1 nF, measuring at voltage 1 V <sub>rms</sub> at 20 °C f = 1 KHz for C > 1 nF, measuring at voltage 1 V <sub>rms</sub> at 20 °C X7R: f = 1 KHz for C ≤ 10 μF, measuring at voltage 1 V <sub>rms</sub> at 20 °C	In accordance with specification
Insulation Resistance	4.5.3	U <sub>r</sub> ≥ 500 V: At 500 V for 1 minute	In accordance with specification



TEST	TEST METHOD	PROCEDURE	REQUIREMENTS									
Temperature Coefficient	4.6	Capacitance shall be measured by the steps shown in the following table.  The capacitance change should be measured after 5 min at each specified temperature stage.	NP0: $\Delta C/C: \pm 30\text{ppm}$  X7R: $\Delta C/C: \pm 15\%$									
		<table border="1"> <thead> <tr> <th>Step</th> <th>Temperature(°C)</th> </tr> </thead> <tbody> <tr> <td>a</td> <td>25±2</td> </tr> <tr> <td>b</td> <td>Lower temperature±3°C</td> </tr> <tr> <td>c</td> <td>25±2</td> </tr> <tr> <td>d</td> <td>Upper Temperature±2°C</td> </tr> <tr> <td>e</td> <td>25±2</td> </tr> </tbody> </table> <p>(1) NP0: Temperature Coefficient shall be calculated from the formula as below  <math display="block">\text{Temp. Coefficient} = \frac{C2 - C1}{C1 \times \Delta T} \times 10^6 \text{ [ppm/°C]}</math>                     C1: Capacitance at step c                      C2: Capacitance at 125°C                      ΔT: 100°C (=125°C -25°C)</p> <p>(2) X7R: Capacitance Change shall be calculated from the formula as below  <math display="block">\Delta C = \frac{C2 - C1}{C1} \times 100\%</math>                     C1: Capacitance at step c                      C2: Capacitance at step b or d</p>		Step	Temperature(°C)	a	25±2	b	Lower temperature±3°C	c	25±2	d
Step	Temperature(°C)											
a	25±2											
b	Lower temperature±3°C											
c	25±2											
d	Upper Temperature±2°C											
e	25±2											
Adhesion	IEC 60384-21/22	4.7 A force applied for 10 seconds to the line joining the terminations and in a plane parallel to the substrate	Force size ≥ 0603: 5N									
Bending Strength		4.8 Mounting in accordance with IEC 60384-22 paragraph 4.3  Conditions: bending 1 mm at a rate of 1 mm/s, radius jig 5 mm	No visible damage  ΔC/C NP0: within ±1% or 0.5 pF, whichever is greater X7R: ±10%									

TEST	TEST METHOD	PROCEDURE	REQUIREMENTS
Resistance to Soldering Heat	4.9	<p>Precondition: 150 +0/-10 °C for 1 hour, then keep for 24 ±1 hours at room temperature</p> <p>Preheating: for size ≤ 1206: 120 °C to 150 °C for 1 minute</p> <p>Preheating: for size &gt;1206: 100 °C to 120 °C for 1 minute and 170 °C to 200 °C for 1 minute</p> <p>Solder bath temperature: 260 ±5 °C</p> <p>Dipping time: 10 ±0.5 seconds</p> <p>Recovery time: 24 ±2 hours</p>	<p>Dissolution of the end face plating shall not exceed 25% of the length of the edge concerned</p> <hr/> <p>ΔC/C</p> <p>NP0: within ±0.5% or 0.5 pF, whichever is greater</p> <p>X7R: ±10%</p> <hr/> <p>D.F. within initial specified value</p> <p>R<sub>ins</sub> within initial specified value</p>
Solderability	4.10	<p>Preheated to a temperature of 80 °C to 140 °C and maintained for 30 seconds to 60 seconds.</p> <p>1. Temperature: 235±5°C / Dipping time: 2 ±0.5 s</p> <p>2. Temperature: 245±5°C / Dipping time: 3 ±0.5 s (lead free)Depth of immersion: 10mm</p>	<p>The solder should cover over 95% of the critical area of each termination</p>
Rapid Change of Temperature	IEC 60384-21/22 4.11	<p>Preconditioning: 150 +0/-10 °C for 1 hour, then keep for 24 ±1 hours at room temperature</p> <p>5 cycles with following detail: 30 minutes at lower category temperature 30 minutes at upper category temperature</p> <p>Recovery time 24 ±2 hours</p>	<p>No visual damage</p> <hr/> <p>ΔC/C</p> <p>NP0: within ±1% or 1 pF, whichever is greater</p> <p>X7R: ±15%</p> <hr/> <p>D.F. meet initial specified value</p> <p>R<sub>ins</sub> meet initial specified value</p>
Damp Heat	4.13	<p>1. Preconditioning, class 2 only: 150 +0/-10 °C /1 hour, then keep for 24 ±1 hour at room temp</p> <p>2. Initial measure: Spec: refer to initial spec C, D, IR</p> <p>3. Damp heat test: 500 ±12 hours at 40 ±2 °C; 90 to 95% R.H.</p> <p>4. Recovery: NP0: 6 to 24 hours X7R: 24 ±2 hours</p> <p>5. Final measure: C, D, IR</p> <p>P.S. If the capacitance value is less than the minimum value permitted, then after the other measurements have been made the capacitor shall be preconditioned according to "IEC 60384 4.1" and then the requirement shall be met.</p>	<p>No visual damage after recovery</p> <hr/> <p>ΔC/C</p> <p>NP0: within ±2% or 1 pF, whichever is greater</p> <p>X7R: ±15%</p> <p>D.F.</p> <p>NP0: ≤ 2 × specified value</p> <p>X7R: ≥ 25 V: ≤ 5%</p> <p>R<sub>ins</sub></p> <p>NP0: ≥ 2,500 MΩ or R<sub>ins</sub> × C<sub>r</sub> ≥ 25s whichever is less</p> <p>X7R: ≥ 500 MΩ or R<sub>ins</sub> × C<sub>r</sub> ≥ 25s whichever is less</p>

TEST	TEST METHOD	PROCEDURE	REQUIREMENTS									
Endurance	IEC 60384-21/22 4.14	<p>1. Preconditioning, X7R only: 150 +0/-10 °C /1 hour, then keep for 24 ±1 hour at room temp</p> <p>2. Initial measure: Spec: refer to initial spec C, D, IR</p> <p>Endurance test: Temperature: NP0/X7R: 125 °C Specified stress voltage applied for 1,000 hours. High-Voltage series follows the stress conditions below:</p> <table border="1"> <thead> <tr> <th>Voltage</th> <th>NPO</th> <th>X7R</th> </tr> </thead> <tbody> <tr> <td>500/630V</td> <td>1.3 × Ur</td> <td>1.2 × Ur</td> </tr> <tr> <td>≥ 1KV</td> <td>1.2 × Ur</td> <td>1.1 × Ur</td> </tr> </tbody> </table> <p>3. Recovery time: 24 ±2 hours</p> <p>4. Final measure: C, D, IR</p> <p>P.S. If the capacitance value is less than the minimum value permitted, then after the other measurements have been made the capacitor shall be preconditioned according to "IEC 60384 4.1" and then the requirement shall be met.</p>	Voltage	NPO	X7R	500/630V	1.3 × Ur	1.2 × Ur	≥ 1KV	1.2 × Ur	1.1 × Ur	<p>No visual damage</p> <hr/> <p><math>\Delta C/C</math> NP0: within ±2% or 1 pF, whichever is greater X7R: ±15% D.F. NP0: ≤ 2 × specified value X7R: ≥ 25 V: ≤ 5% <math>R_{ins}</math> NP0: ≥ 4,000 MΩ or <math>R_{ins} \times C_r \geq 40s</math> whichever is less X7R: ≥ 1,000 MΩ or <math>R_{ins} \times C_r \geq 50s</math> whichever is less</p>
Voltage	NPO	X7R										
500/630V	1.3 × Ur	1.2 × Ur										
≥ 1KV	1.2 × Ur	1.1 × Ur										

Voltage Proof	Specified stress voltage applied for 1~5 seconds Ur = 500 V series applied (1.3 Ur + 100) Ur > 500 V: 1.3 Ur Ur ≥ 1KV: 1.2 Ur Charge/Discharge current less than 50mA	No breakdown or flashover
---------------	--	---------------------------

REVISION HISTORY

REVISION	DATE	CHANGE NOTIFICATION	DESCRIPTION
Version 15	Dec. 15, 2021	-	- I.R. Spec. updated X7R/0805/≥3.9nF X7R/1206/≥12nF X7R/1210/≥12nF X7R/1808/≥18nF X7R/1812/≥27nF X7R/2220/≥150nF
Version 14	Oct. 26, 2021	-	- Add 500V/630V
Version 13	Feb. 28, 2021	-	- Add NP0/1206/0.47pF to 10pF with 0.85 mm
Version 12	Dec. 01, 2020	-	- Add X7R/0805/1.5nF to 3.3nF/1KV. NP0/0805/ 56pF to 82pF/1KV
Version 11	Jul. 13, 2018	-	- Add NP0/1206/10pF to 47pF/3KV
Version 10	Mar. 7, 2017	-	- 0805 L4 spec updated
Version 9	Jan. 16, 2017	-	- Product range updated
Version 8	Oct. 12, 2015	-	- Product range updated
Version 7	May 21, 2014	-	- Product range updated
Version 6	Jun. 17, 2012	-	- Product range updated
Version 5	Sep 25, 2012	-	- Product range updated
Version 4	Aug 08, 2011	-	- Product range updated
Version 3	Jan 19, 2011	-	- Dimension updated - Add NP0 0805 1KV
Version 2	Feb 02, 2010	-	- Change to dual brand datasheet that describe High-Voltage NP0/X7R series with RoHS compliant - Replace the high voltage part of pdf files: UP-NP0X7R_HV_1K-to-4KV_I and UY-NP0X7R_HV_1K-to-4KV_I - Description of "Halogen Free compliant" added - Product range updated - Define global part number - Test method and procedure updated
Version 1	Sep 30, 2005	-	- Thickness revised
Version 0	Sep 12, 2005	-	- New