

## Data sheet

Commercial Art.No.: 57.503.0055.2

Feed-through terminal WK 2,5 / U WS / V0

Feed-through terminal with Screw connection for mounting on TS 35 / TS 32, nominal cross section: 2.5 mm<sup>2</sup>, Width: 5 mm, Color: white



Commercial Art.No.	57.503.0055.2
EAN	4015573974432
Order Unit	100

Certificates / Approvals



**CAN-Ex**



**ATEX**



**USA-Ex**

## Technical data

### Classification

ECLASS 11	
ECLASS 8.1	27141120
ETIM 7.0	EC000897
ETIM 6.0	EC000897
ETIM 5.0	EC000897
ETIM 4.0	EC000897

### Product compliance

ROHS conformity status	Compliant
REACH-SVHC conformity status	Compliant

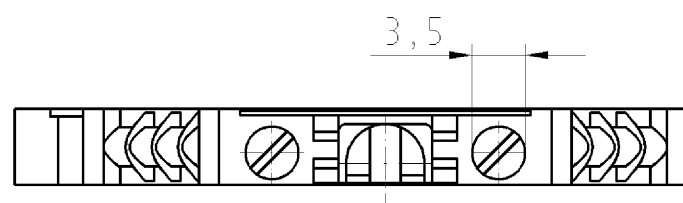
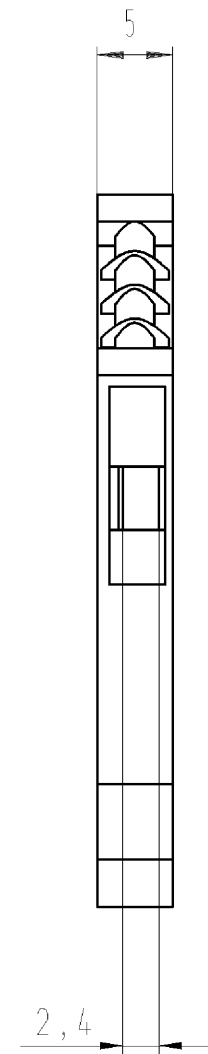
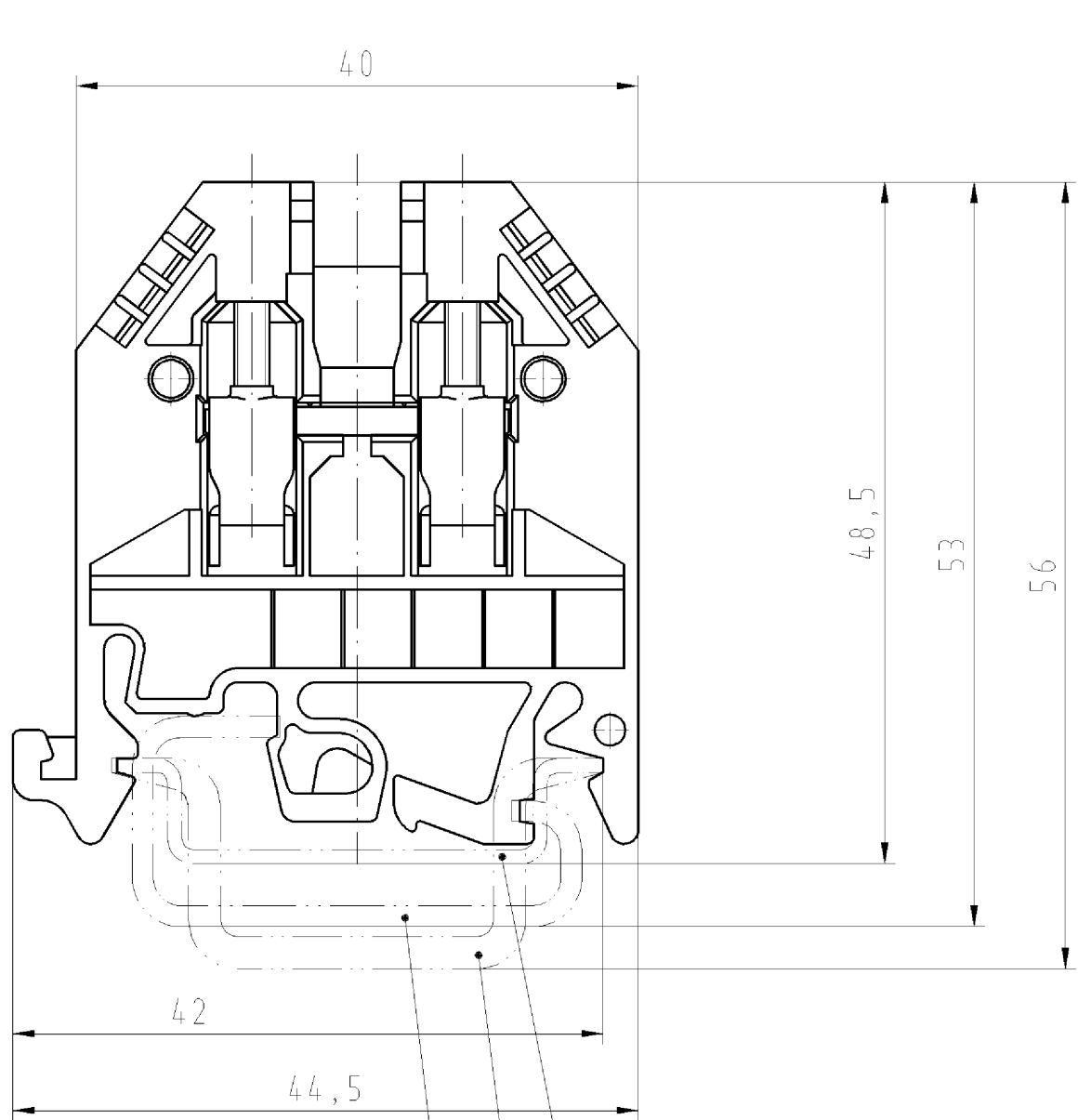

- Hutschiene EN 50022-35x7,5  
mountail rail EN 50022-35x7,5
- Hutschiene EN 50022-35x15  
mountail rail EN 50022-35x15
- G-Schiene EN 50035-G32  
G-rail EN 50035-G32

Weitere Daten siehe Katalog  
further data see catalog

Teile-Nr./part-nr.	Farbe/colour	Typ/type
57.503.0055.0	grau/grey	WK 2,5 U /VO
57.503.0055.1	schwarz/black	WK 2,5 U schwarz/VO
57.503.0055.2	weiß/white	WK 2,5 U weiß/VO
57.503.0055.3	schiefergrau/slate grey	WK 2,5 U schiefergrau/VO
57.503.0055.4	braun/brown	WK 2,5 U braun/VO
57.503.0055.5	rot/red	WK 2,5 U rot/VO
57.503.0055.6	blau/blue	WK 2,5 U blau/VO
57.506.0055.7	grün/green	WK 2,5 U grün/VO
57.503.0055.8	gelb/yellow	WK 2,5 U gelb/VO
57.503.0055.9	orange/orange	WK 2,5 U orange/VO

Freitoleranz nach DIN		CAD - Zeichnung, keine manuellen Änderungen			1. Verwendung: -		Bl.: 1 von 1		
	/	Maßstab	2003	Tag	Name	T	Zeichnung Nr.		
	/		Entworfen	10.04.	Schmitt J.		57.503.0055.0 01K		a
	/		Geprüft	-	-		Ersatz für: -		
	/	a	Normgepr.	-	-	Benennung			
	/		Änderung		DURCHGANGSKLEMME				
		<b>wieland</b> Elektrische Verbindungen		terminal					
Buchstabe	Datum / Blatt								

○ Diese Maße werden bei Abnahme besonders geprüft  
 ○ Ausschließlich Prüfmaße  
 ○ Mit /E gekennzeichnete Maße sind nur für interne Zwecke gültig

Weitergabe sowie Vervielfältigung dieses Dokuments, Verwertung und Mitteilung seines Inhalts sind verboten, soweit nicht ausdrücklich gestattet. The reproduction, distribution and utilization of this document as well as the communication of its contents to others without express authorization is prohibited.

1  
2  
3  
4  
5  
6  
7  
8  
9  
10  
11  
12  
13  
14  
15  
16  
17  
18  
19  
20  
M1  
M2  
M3  
L  
G  
1.1  
2.1  
1.1  
575030055001K\_4\_CADW1044\_treschan 2007-06-27T15:12:19 1.000