

未注公差/General tolerances (mm)											0.1/10 ±2'			
0 ~ 3	>3 ~ 6	>6 ~ 10	>10 ~ 18	>18 ~ 30	>30 ~ 50	>50 ~ 80	>80 ~ 120	>120 ~ 180	>180 ~ 250	>250 ~ 315		>315 ~ 400	>400 ~ 500	>500
±0.12	±0.18	±0.22	±0.26	±0.31	±0.37	±0.57	±0.80	±0.93	±1.05	±1.15	±1.60	±2.20	±2.50	

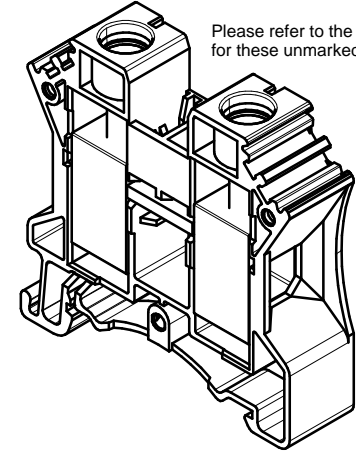
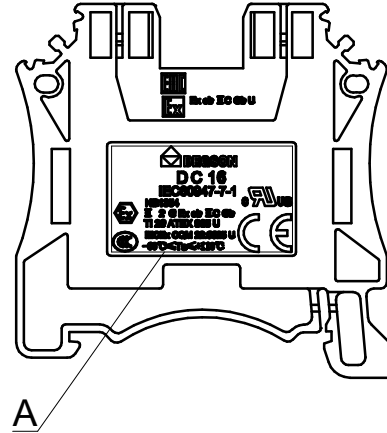
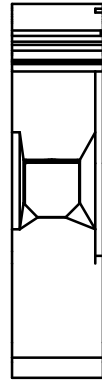
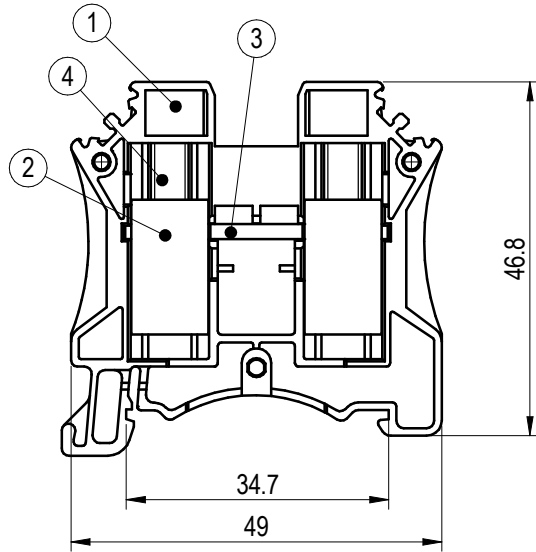
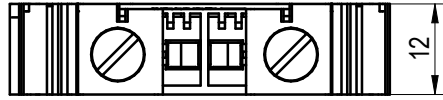

Please refer to the 3D model, for these unmarked dimensions.

ITEM	NAME OF PART	MATERIAL	NOTES
4	Screw	Stainless steel	M5
3	Current carrier	Copper	Sn Plated
2	Cage	Copper alloy	Ni Plated
1	Housing	PA66	UL94V-0

A
2:1

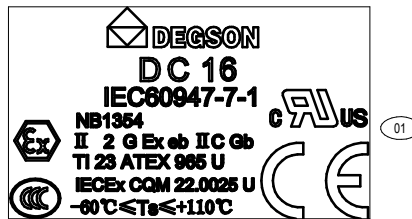

UL 标准/UL Standard:	B	C	D
额定电压/电流/Rated Voltage(V)/Current(A)	600/100	600/100	/
IEC 标准/IEC Standard:			
过压类别/Overvoltage Category/污染等级/Pollution Degree	III/3	III/2	II/2
额定电压/电流/Rated Voltage(V)/Current(A)	1000/76	/	/
额定脉冲电压(KV)/Rate Impulse Voltage(KV)	8	/	/
螺丝扭矩/Torque Tightening(N·m/Lb.in)		M5, 2.5/27.0	
线径范围(硬线和软线)/Wire Range(rigid and flexible)(AWG/mm ²)	14~ 3/ 1.5~ 25		
间距/Pitch(mm)/线数范围/Poles	12/01P		
剥线长度/Stripping length(mm)	12~ 13		
使用温度范围/Operating temperature(°C)	-40~ + 105		
符合RoHS环保要求/Conform to RoHS	Yes		
标准颜色编号/Standard color number: PANTONE/ RAL	/		

MATERIAL:		SURFACE/COLOR:	
MAT NO./REV: 11020000290-1 / 00		MAT STATUS: 批量	
APPD: Peng M	2024.01.30	NAME	
CHKD: Gao WG	2024.01.30	DC16-Cu-01P-11-200A(H)	
DRFT: Deng L	2024.01.30	DRAWING NO.	TYPE
A4		200087555	CUSTOMER DRAWING
		DRAWING STATUS	SCALE
		已发布	1:1
		SHEET	1/1

REV	ECN	DESCRIPTION	DRFT	DATE
01		Add 3C and explosion-proof mark	Deng L	2024.01.30

Transfer or duplication of this document as well as the utilization or communication of its contents are prohibited unless and until authorization is granted. Warnings will be taken for compensation. All rights reserved for patent. 未经授权复制或传播本文件内容，或在本文件内容中提及的任何产品、服务、商标、名称、专利、注册商标或商号，均受法律保护。未经授权的复制或传播，或在本文件内容中提及的任何产品、服务、商标、名称、专利、注册商标或商号，均受法律保护。所有权利保留。如有侵权，我们将追究法律责任。