

DRV8872-Q1 Automotive 3.6-A Brushed DC Motor Driver With Fault Reporting

1 Features

- AEC-Q100 Qualified for Automotive Applications:
 - Device Temperature Grade 1: -40°C to $+125^{\circ}\text{C}$ Ambient Operating Temperature Range
 - Device HBM ESD Classification Level 2
 - Device CDM ESD Classification Level C4B
- H-Bridge Motor Driver
 - Drives One DC Motor, One Winding of a Stepper Motor, or Other Loads
- Wide 6.8-V to 45-V Operating Voltage
- $565\text{-m}\Omega$ Typical $R_{\text{DS(on)}}$ (HS + LS)
- 3.6-A Peak Current Drive
- PWM Control Interface
- Integrated Current Regulation
- Low-Power Sleep Mode
- Fault Status Output Pin
- Small Package and Footprint
 - 8-Pin HSOP With PowerPAD™
 - $4.9 \times 6 \text{ mm}$
- **Integrated Protection Features**
 - VM Undervoltage Lockout (UVLO)
 - Overcurrent Protection (OCP)
 - Thermal Shutdown (TSD)
 - Fault Reporting (nFAULT)
 - Automatic Fault Recovery

2 Applications

- Automotive Infotainment
- HUD Projector Adjustment
- Motorized Shifter Knobs
- Piezo Horn Driver

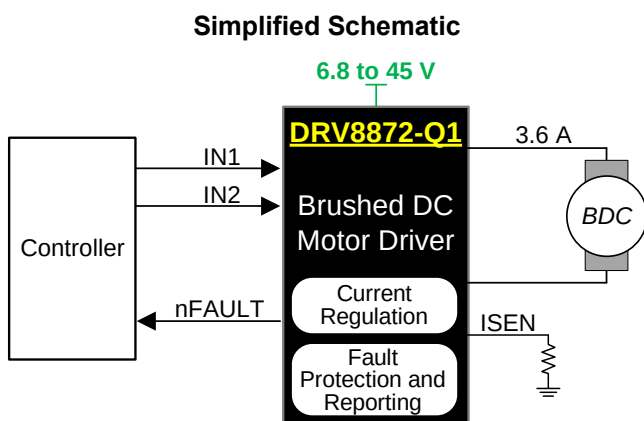

3 Description

The DRV8872-Q1 device is a brushed DC (BDC) motor driver for infotainment, HUD projector adjustment, motorized shifter knobs, and piezo horn drivers. Two logic inputs control the H-bridge driver, which consists of four N-channel MOSFETs that provide bidirectional control of motors up to 3.6-A peak current. The inputs can be pulse-width modulated (PWM) to control motor speed, using a choice of current-decay modes. Setting both inputs low enters a low-power sleep mode.

The DRV8872-Q1 device features integrated current regulation, based on an internal reference voltage and the voltage on the ISEN pin, which is proportional to motor current through an external sense resistor. The ability to limit current to a known level can significantly reduce the system power requirements and bulk capacitance needed to maintain stable voltage, especially for motor startup and stall conditions.

The device is fully protected from faults and short circuits, including undervoltage lockout (UVLO), overcurrent protection (OCP), and thermal shutdown (TSD). Faults are communicated by pulling the nFAULT output low. When the fault condition is removed, the device automatically resumes normal operation.

Device Information⁽¹⁾

PART NUMBER	PACKAGE	BODY SIZE (NOM)
DRV8872-Q1	HSOP (8)	4.90 mm × 6.00 mm

(1) For all available packages, see the orderable addendum at the end of the data sheet.

H-Bridge States

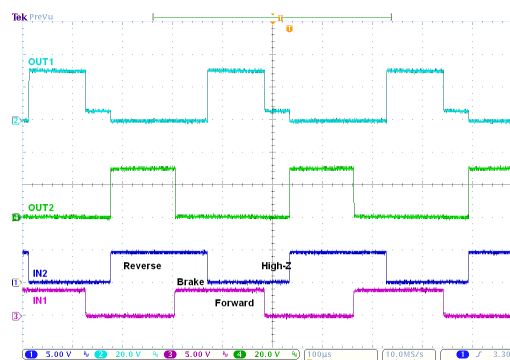

Table of Contents

1 Features 1 2 Applications 1 3 Description 1 4 Revision History 2 5 Pin Configuration and Functions 3 6 Specifications 3 6.1 Absolute Maximum Ratings 3 6.2 ESD Ratings..... 4 6.3 Recommended Operating Conditions 4 6.4 Thermal Information 4 6.5 Electrical Characteristics..... 5 6.6 Typical Characteristics 6 7 Detailed Description 7 7.1 Overview 7 7.2 Functional Block Diagram 7 7.3 Feature Description..... 8 7.4 Device Functional Modes..... 10 8 Application and Implementation 11	8.1 Application Information..... 11 8.2 Typical Application 11 9 Power Supply Recommendations 14 9.1 Bulk Capacitance 14 10 Layout 15 10.1 Layout Guidelines 15 10.2 Layout Example 15 10.3 Thermal Considerations 15 10.4 Power Dissipation 15 11 Device and Documentation Support 17 11.1 Documentation Support 17 11.2 Receiving Notification of Documentation Updates 17 11.3 Community Resources..... 17 11.4 Trademarks 17 11.5 Electrostatic Discharge Caution 17 11.6 Glossary 17 12 Mechanical, Packaging, and Orderable Information 17
---	--

4 Revision History

NOTE: Page numbers for previous revisions may differ from page numbers in the current version.

DATE	REVISION	NOTES
November 2016	*	Initial release.

5 Pin Configuration and Functions

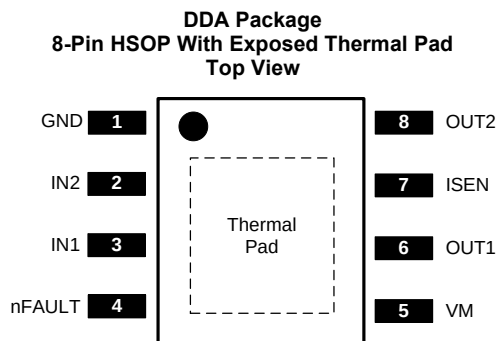

Pin Functions

PIN		TYPE	DESCRIPTION	
NAME	NO.			
GND	1	PWR	Logic ground	Connect to board ground.
IN1	3	I	Logic inputs	Controls the H-bridge output. Has internal pulldowns. (See Table 1.)
IN2	2			
ISEN	7	PWR	High-current ground path	If using current regulation, connect ISEN to a resistor (low-value, high-power-rating) to ground. If not using current regulation, connect ISEN directly to ground.
nFAULT	4	OD	Fault status (open-drain)	Low-level indicates UVLO, TSD, or OCP fault. Connect to a pullup resistor.
OUT1	6	O	H-bridge outputs	Connect directly to the motor, or other inductive load.
OUT2	8			
VM	5	PWR	6.8-V to 45-V power supply	Connect a 0.1- μ F bypass capacitor to ground, as well as sufficient bulk capacitance, rated for the VM voltage.
PAD	—	—	Thermal pad	Connect to board ground. For good thermal dissipation, use large ground planes on multiple layers, and multiple nearby vias connecting those planes.

6 Specifications

6.1 Absolute Maximum Ratings

over operating free-air temperature range (unless otherwise noted)⁽¹⁾

	MIN	MAX	UNIT
Power supply voltage (VM)	-0.3	50	V
Logic input voltage (IN1, IN2)	-0.3	7	V
Fault pin (nFAULT)	-0.3	6	V
Continuous phase node pin voltage (OUT1, OUT2)	-0.7	VM + 0.7	V
Current sense input pin voltage (ISEN) ⁽²⁾	-0.5	1	V
Output current (100% duty cycle)		3.5	A
Operating junction temperature, T _J	-40	150	°C
Storage temperature, T _{stg}	-65	150	°C

(1) Stresses beyond those listed under *Absolute Maximum Ratings* may cause permanent damage to the device. These are stress ratings only, which do not imply functional operation of the device at these or any other conditions beyond those indicated under *Recommended Operating Conditions*. Exposure to absolute-maximum-rated conditions for extended periods may affect device reliability.

(2) Transients of ± 1 V for less than 25 ns are acceptable

6.2 ESD Ratings

		VALUE	UNIT	
$V_{(ESD)}$ Electrostatic discharge	Human-body model (HBM), per AEC Q100-002 ⁽¹⁾	±2000	V	
	Charged-device model (CDM), per AEC Q100-011	All pins		±500
		Corner pins (1, 4, 5, and 8)		±750

(1) AEC Q100-002 indicates that HBM stressing shall be in accordance with the ANSI/ESDA/JEDEC JS-001 specification.

6.3 Recommended Operating Conditions

over operating free-air temperature range (unless otherwise noted)

		MIN	NOM	MAX	UNIT
V_M	Power supply voltage	6.8		45	V
V_I	Logic input voltage (IN1, IN2)	0		5.5	V
f_{PWM}	Logic input PWM frequency (IN1, IN2)	0		200 ⁽¹⁾	kHz
I_{peak}	Peak output current ⁽²⁾	0		3.6	A
T_A	Operating ambient temperature	–40		125	°C

(1) The voltages applied to the inputs should have at least 800 ns of pulse width to ensure detection. Typical devices require at least 400 ns. If the PWM frequency is 200 kHz, the usable duty cycle range is 16% to 84%

(2) Power dissipation and thermal limits must be observed

6.4 Thermal Information

THERMAL METRIC ⁽¹⁾		DRV8872-Q1	UNIT
		DDA (HSOP)	
		8 PINS	
$R_{\theta JA}$	Junction-to-ambient thermal resistance	41.7	°C/W
$R_{\theta JC(top)}$	Junction-to-case (top) thermal resistance	53.7	°C/W
$R_{\theta JB}$	Junction-to-board thermal resistance	12.4	°C/W
Ψ_{JT}	Junction-to-top characterization parameter	3	°C/W
Ψ_{JB}	Junction-to-board characterization parameter	12.6	°C/W
$R_{\theta JC(bot)}$	Junction-to-case (bottom) thermal resistance	2.6	°C/W

(1) For more information about traditional and new thermal metrics, see the [Semiconductor and IC Package Thermal Metrics](#) application report (SPRA953).

6.5 Electrical Characteristics

Over recommended operating conditions unless otherwise noted. Typical limits apply for $T_A = 25^\circ\text{C}$ and $V_{VM} = 24\text{ V}$

PARAMETER		TEST CONDITIONS	MIN	TYP	MAX	UNIT
POWER SUPPLY (VM)						
V_{VM}	VM operating voltage		6.8		45	V
I_{VM}	VM operating supply current			3	10	mA
$I_{VMSLEEP}$	VM sleep current	$V_M = 12\text{ V}$			13	μA
t_{ON}	Turnon time ⁽¹⁾	$V_M > V_{UVLO}$ with IN1 or IN2 high		40	50	μs
LOGIC-LEVEL INPUTS (IN1, IN2)						
V_{IL}	Input logic low voltage				0.5	V
V_{IH}	Input logic high voltage		1.6			V
V_{HYS}	Input logic hysteresis			0.5		V
I_{IL}	Input logic low current	$V_{IN} = 0\text{ V}$	-1		1	μA
I_{IH}	Input logic high current	$V_{IN} = 3.3\text{ V}$		33	100	μA
R_{PD}	Pulldown resistance	To GND		100		k Ω
t_{PD}	Propagation delay	INx to OUTx change (see Figure 6)		0.7	1	μs
t_{sleep}	Time to sleep	Inputs low to sleep		1	1.5	ms
MOTOR DRIVER OUTPUTS (OUT1, OUT2)						
$R_{DS(ON)}$	High-side FET on resistance	$V_M = 24\text{ V}$, $I = 1\text{ A}$, $f_{PWM} = 25\text{ kHz}$		307	610	m Ω
$R_{DS(ON)}$	Low-side FET on resistance	$V_M = 24\text{ V}$, $I = 1\text{ A}$, $f_{PWM} = 25\text{ kHz}$		258	500	m Ω
t_{DEAD}	Output dead time			250		ns
V_d	Body diode forward voltage	$I_{OUT} = 1\text{ A}$		0.8	1	V
CURRENT REGULATION						
V_{TRIP}	ISEN voltage for current chopping		0.32	0.35	0.38	V
t_{OFF}	PWM off-time			25		μs
t_{BLANK}	PWM blanking time			2		μs
PROTECTION CIRCUITS						
V_{UVLO}	VM undervoltage lockout	VM falls until UVLO triggers		6.3	6.5	V
		VM rises until operation recovers		6.4	6.7	
$V_{UV,HYS}$	VM undervoltage hysteresis	Rising to falling threshold	100	180		mV
I_{OCP}	Overcurrent protection trip level		3.7	4.5	6.6	A
t_{OCP}	Overcurrent deglitch time			2		μs
t_{RETRY}	Overcurrent retry time			3		ms
T_{SD}	Thermal shutdown temperature ⁽²⁾		155	180		$^\circ\text{C}$
T_{HYS}	Thermal shutdown hysteresis ⁽²⁾			40		$^\circ\text{C}$
nFAULT OPEN DRAIN OUTPUT						
V_{OL}	Output low voltage	$I_O = 5\text{ mA}$			0.5	V
I_{OH}	Output high leakage current	$V_O = 3.3\text{ V}$			1	μA

(1) t_{ON} applies when the device initially powers up, and when it exits sleep mode.

(2) Ensured by design

6.6 Typical Characteristics

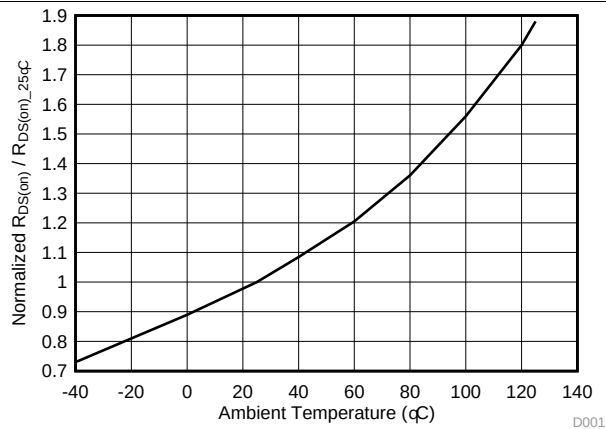

Figure 1. $R_{DS(on)}$ vs Temperature

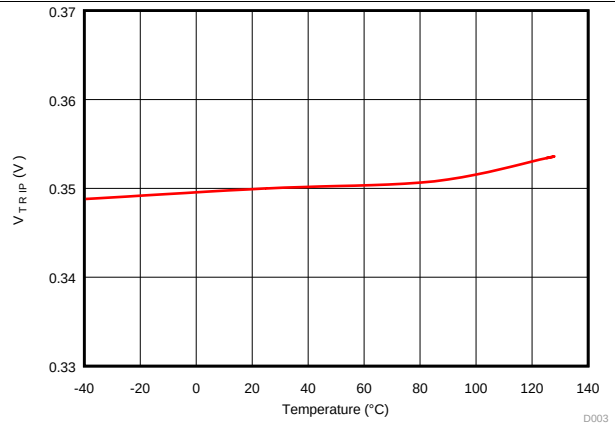

Figure 2. V_{TRIP} vs Temperature

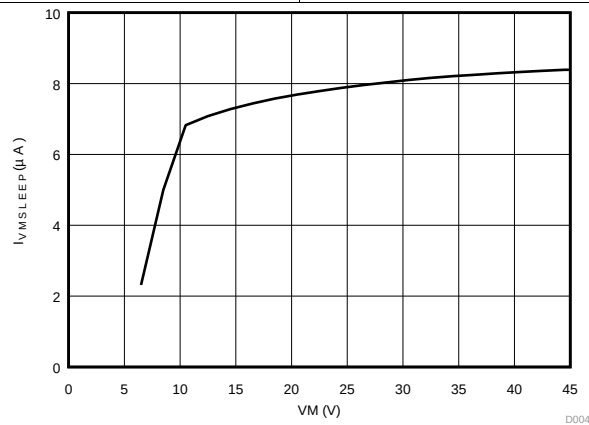

Figure 3. $I_{VMSLEEP}$ vs VM at 25°C

7 Detailed Description

7.1 Overview

The DRV8872-Q1 device is an optimized 8-pin device for driving brushed DC motors with 6.8 to 45 V and up to 3.6-A peak current. The integrated current regulation restricts motor current to a predefined maximum. Two logic inputs control the H-bridge driver, which consists of four N-channel MOSFETs that have a typical $R_{ds(on)}$ of 565 m Ω (including one high-side and one low-side FET). A single power input, VM, serves as both device power and the motor winding bias voltage. The integrated charge pump of the device boosts VM internally and fully enhances the high-side FETs. Motor speed can be controlled with pulse-width modulation, at frequencies between 0 to 200 kHz. The device has an integrated sleep mode that is entered by bringing both inputs low. An assortment of protection features prevent the device from being damaged if a system fault occurs.

7.2 Functional Block Diagram

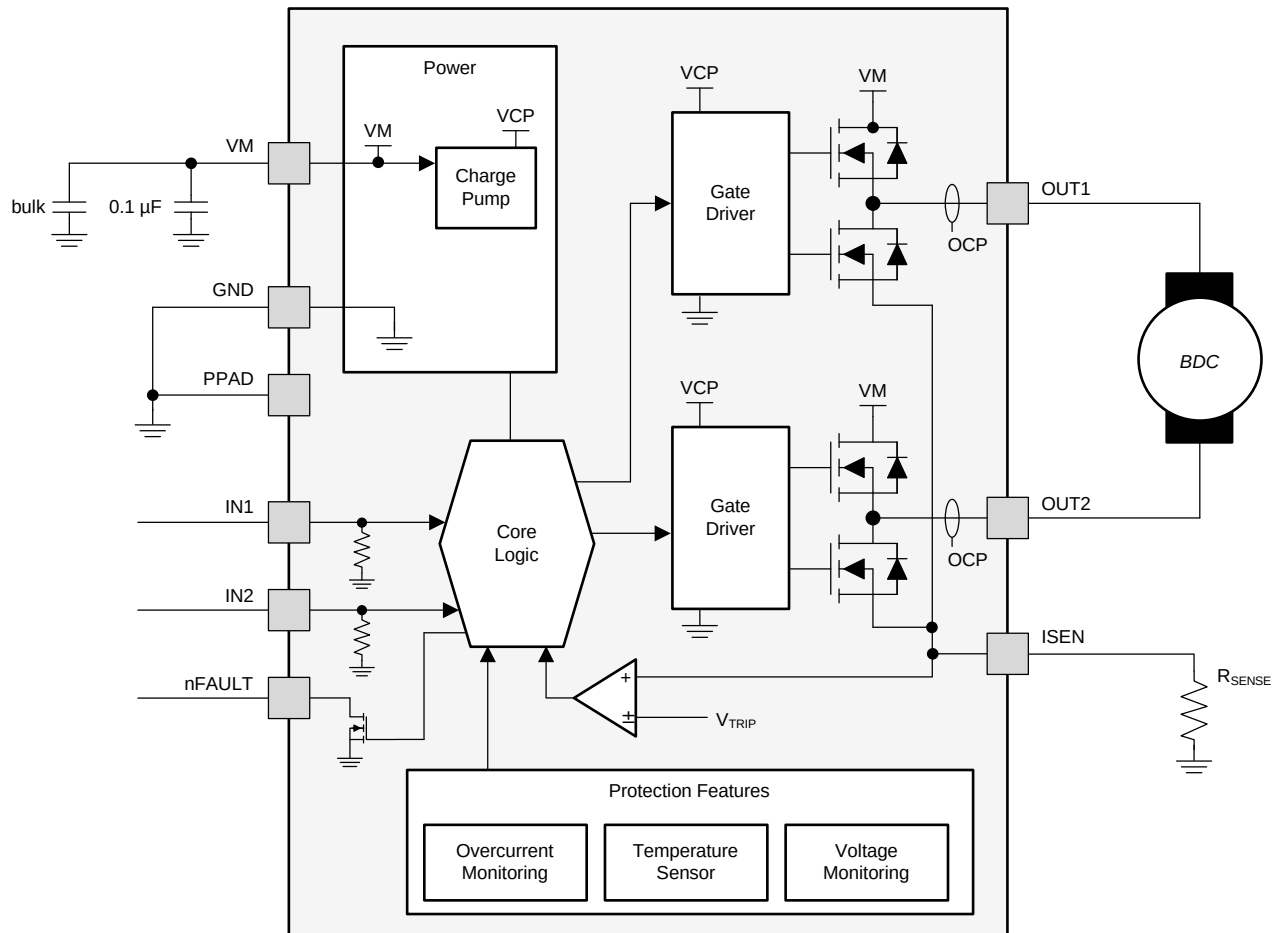

Copyright © 2016, Texas Instruments Incorporated

7.3 Feature Description

7.3.1 Bridge Control

The DRV8872-Q1 output consists of four N-channel MOSFETs that are designed to drive high current. These MOSFETs are controlled by the two logic inputs IN1 and IN2, according to Table 1.

Table 1. H-Bridge Control

IN1	IN2	OUT1	OUT2	DESCRIPTION
0	0	High-Z	High-Z	Coast; H-bridge disabled to High-Z (sleep entered after 1 ms)
0	1	L	H	Reverse (current OUT2 → OUT1)
1	0	H	L	Forward (current OUT1 → OUT2)
1	1	L	L	Brake; low-side slow decay

The inputs can be set to static voltages for 100% duty-cycle drive, or they can be pulse-width modulated (PWM) for variable motor speed. When using PWM, switching between driving and braking typically works best. For example, to drive a motor forward with 50% of its max RPM, IN1 = 1 and IN2 = 0 during the driving period, and IN1 = 1 and IN2 = 1 during the other period. Alternatively, the coast mode (IN1 = 0, IN2 = 0) for fast current decay is also available. The input pins can be powered before VM is applied.

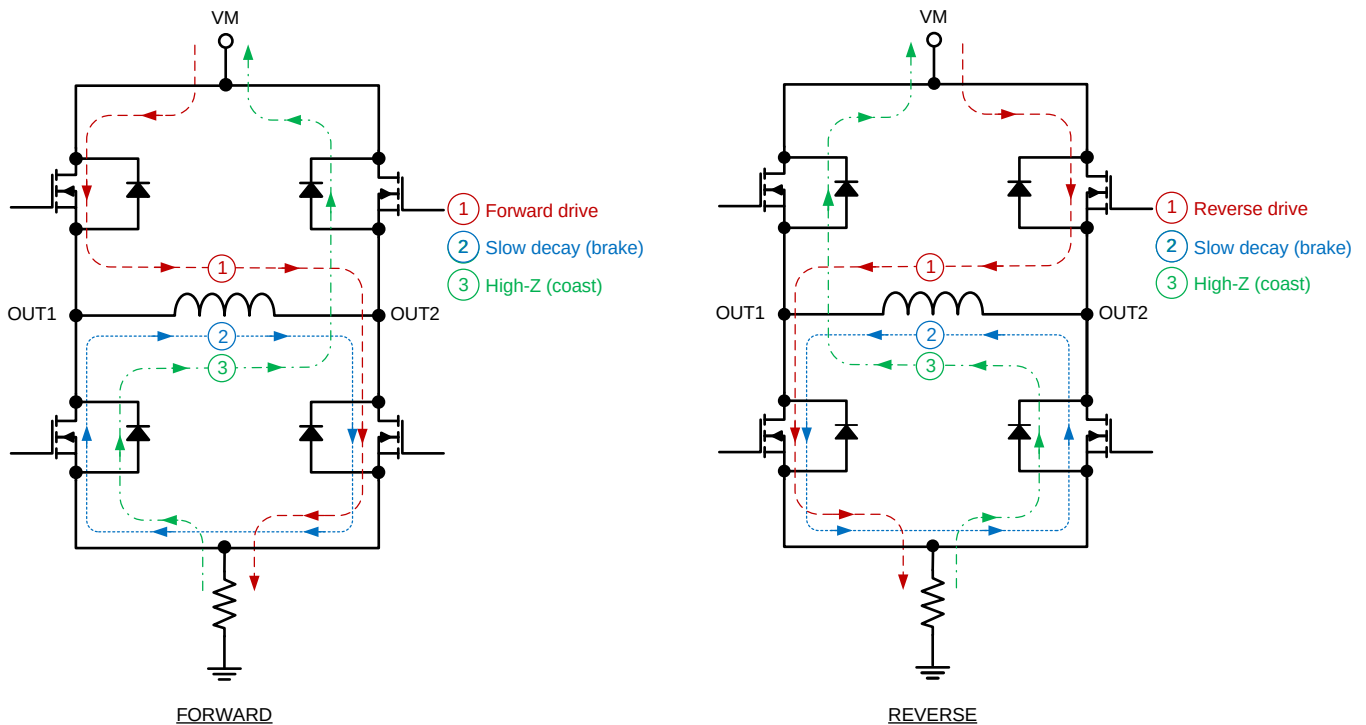

Figure 4. H-Bridge Current Paths

7.3.2 Sleep Mode

When IN1 and IN2 are both low for time t_{SLEEP} (typically 1 ms), the DRV8872-Q1 device enters a low-power sleep mode, where the outputs remain High-Z and the device uses $I_{VMSLEEP}$ (microamps) of current. If the device is powered up while both inputs are low, sleep mode is immediately entered. After IN1 or IN2 are high for at least 5 μs , the device is operational 50 μs (t_{ON}) later.

7.3.3 Current Regulation

The DRV8872-Q1 device limits the output current based on the resistance of an external sense resistor on pin ISEN, according to Equation 1.

$$I_{TRIP} (A) = \frac{V_{TRIP} (V)}{R_{ISEN} (\Omega)} = \frac{0.35 (V)}{R_{ISEN} (\Omega)} \tag{1}$$

For example, if $R_{ISEN} = 0.16 \Omega$, the DRV8872-Q1 device limits motor current to 2.2 A no matter how much load torque is applied. For guidelines on selecting a sense resistor, see the [Sense Resistor](#) section.

When I_{TRIP} has been reached, the device enforces slow current decay by enabling both low-side FETs, and it does this for time t_{OFF} (typically 25 μ s).

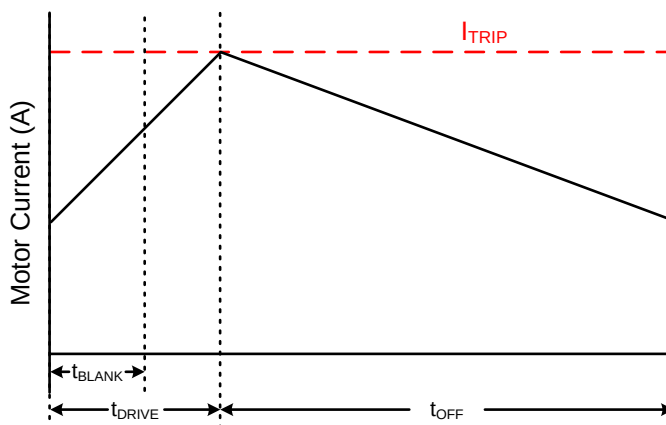

Figure 5. Current Regulation Time Periods

After t_{OFF} has elapsed, the output is re-enabled according to the two inputs IN_x . The drive time (t_{DRIVE}) until reaching another I_{TRIP} event heavily depends on the VM voltage, the back-EMF of the motor, and the inductance of the motor.

7.3.4 Dead Time

When an output changes from driving high to driving low, or driving low to driving high, dead time is automatically inserted to prevent shoot-through. t_{DEAD} is the time in the middle when the output is High-Z. If the output pin is measured during t_{DEAD} , the voltage will depend on the direction of current. If current is leaving the pin, the voltage is a diode drop below ground. If current is entering the pin, the voltage is a diode drop above VM. This diode is the body diode of the high-side or low-side FET.

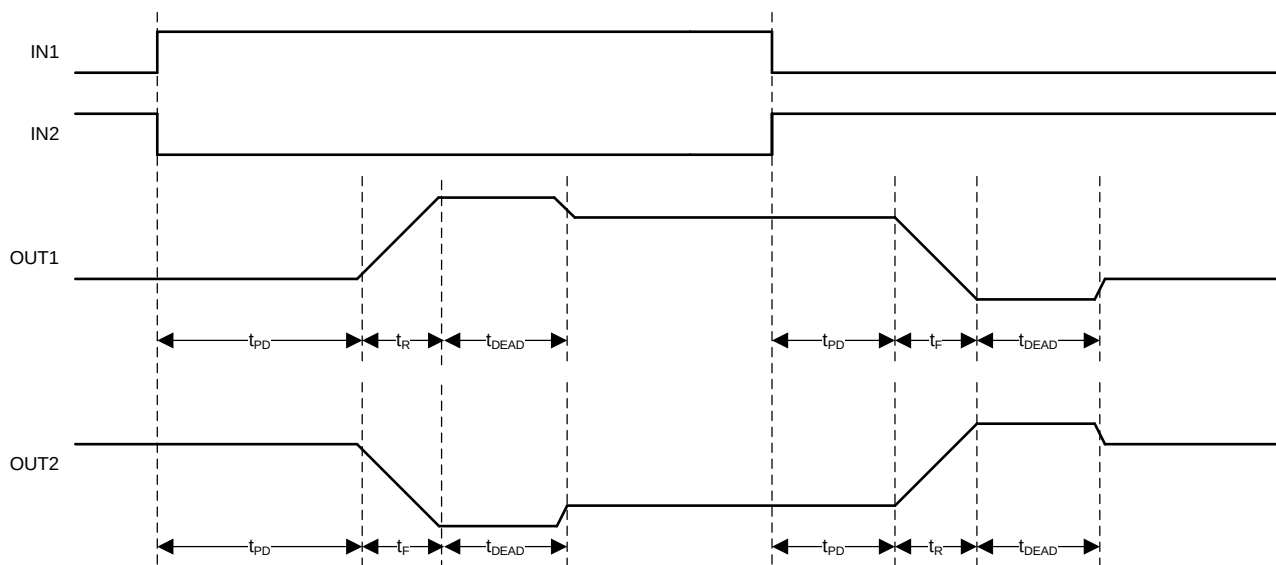

Figure 6. Propagation Delay Time

7.3.5 Protection Circuits

The DRV8872-Q1 device is fully protected against VM undervoltage, overcurrent, and overtemperature events. When the device is in a protected state, nFAULT is driven low. When the fault condition is removed, nFAULT becomes a high-impedance state.

7.3.5.1 VM Undervoltage Lockout (UVLO)

If at any time the voltage on the VM pin falls below the undervoltage-lockout threshold voltage, all FETs in the H-bridge are disabled. Operation resumes when VM rises above the UVLO threshold.

7.3.5.2 Overcurrent Protection (OCP)

If the output current exceeds the OCP threshold I_{OCP} for longer than t_{OCP} , all FETs in the H-bridge are disabled for a duration of t_{RETRY} . After that, the H-bridge re-enables according to the state of the INx pins. If the overcurrent fault is still present, the cycle repeats; otherwise normal device operation resumes.

7.3.5.3 Thermal Shutdown (TSD)

If the die temperature exceeds safe limits, all FETs in the H-bridge is disabled. After the die temperature has fallen to a safe level, operation automatically resumes.

Table 2. Protection Functionality

FAULT	CONDITION	H-BRIDGE BECOMES	NFAULT BECOMES	RECOVERY
VM undervoltage lockout (UVLO)	$VM < V_{UVLO}$	Disabled	Low	$VM > V_{UVLO}$
Overcurrent (OCP)	$I_{OUT} > I_{OCP}$	Disabled	Low	t_{RETRY}
Thermal shutdown (TSD)	$T_J > 150^{\circ}C$	Disabled	Low	$T_J < T_{SD} - T_{HYS}$

7.4 Device Functional Modes

The DRV8872-Q1 device can be used in multiple ways to drive a brushed DC motor.

7.4.1 PWM With Current Regulation

This scheme uses all of the capabilities of the device. The I_{TRIP} current is set above the normal operating current, and high enough to achieve an adequate spin-up time, but low enough to constrain current to a desired level. Motor speed is controlled by the duty cycle of one of the inputs, while the other input is static. Brake and slow decay is typically used during the off-time.

7.4.2 PWM Without Current Regulation

If current regulation is not needed, the ISEN pin should be directly connected to the PCB ground plane. This mode provides the highest possible peak current: up to 3.6 A for a few hundred milliseconds (depending on PCB characteristics and the ambient temperature). If current exceeds 3.6 A, the device might reach overcurrent protection (OCP) or over-temperature shutdown (TSD). If that occurs, the device disables and protects itself for about 3 ms (t_{RETRY}) and then resumes normal operation.

7.4.3 Static Inputs With Current Regulation

The IN1 and IN2 pins can be set high and low for 100% duty cycle drive, and ITRIP can be used to control the current, speed, and torque capability of the motor.

7.4.4 VM Control

In some systems, varying VM as a means of changing motor speed is desirable. See the [Motor Voltage](#) section for more information.

8 Application and Implementation

NOTE

Information in the following applications sections is not part of the TI component specification, and TI does not warrant its accuracy or completeness. TI's customers are responsible for determining suitability of components for their purposes. Customers should validate and test their design implementation to confirm system functionality.

8.1 Application Information

The DRV8872-Q1 device is typically used to drive one brushed DC motor.

8.2 Typical Application

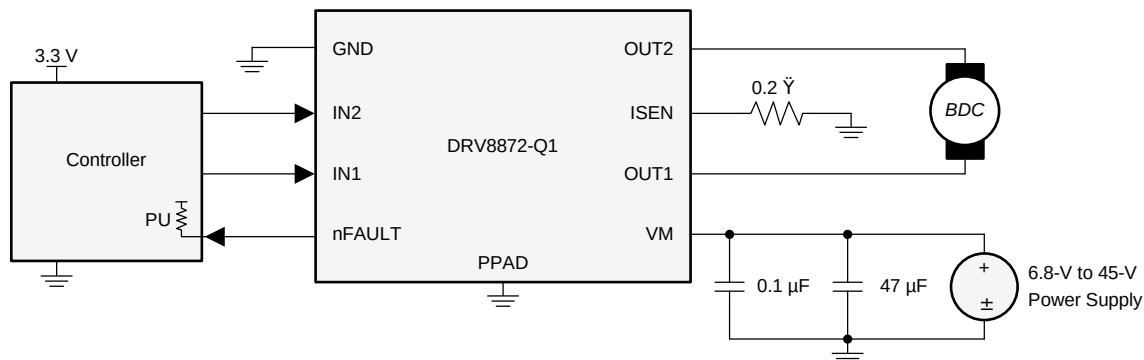

Copyright © 2016, Texas Instruments Incorporated

Figure 7. Typical Connections

8.2.1 Design Requirements

Table 3 lists the design parameters.

Table 3. Design Parameters

DESIGN PARAMETER	REFERENCE	EXAMPLE VALUE
Motor voltage	V_M	24 V
Motor RMS current	I_{RMS}	0.8 A
Motor startup current	I_{START}	2 A
Motor current trip point	I_{TRIP}	2.2 A
Sense resistance	R_{ISEN}	0.16 Ω
PWM frequency	f_{PWM}	5 kHz

8.2.2 Detailed Design Procedure

8.2.2.1 Motor Voltage

The motor voltage used depends on the ratings of the motor selected and the desired RPM. A higher voltage spins a brushed DC motor faster with the same PWM duty cycle applied to the power FETs. A higher voltage also increases the rate of current change through the inductive motor windings.

8.2.2.2 Drive Current

The current path is through the high-side sourcing DMOS power driver, motor winding, and low-side sinking DMOS power driver. Power dissipation losses in one source and sink DMOS power driver are shown in Equation 2.

$$P_D = I^2 R_{DS(on)Source} + I^2 R_{DS(on)Sink} \quad (2)$$

The DRV8872-Q1 device has been measured to be capable of 2-A RMS current at 25°C on standard FR-4 PCBs. The maximum RMS current varies based on the PCB design, ambient temperature, and PWM frequency. Typically, switching the inputs at 200 kHz compared to 20 kHz causes 20% more power loss in heat.

8.2.2.3 Sense Resistor

For optimal performance, the sense resistor must have the features that follow:

- Surface-mount device
- Low inductance
- Rated for high enough power
- Placed closely to the motor driver

The power dissipated by the sense resistor equals $I_{RMS}^2 \times R$. For example, if peak motor current is 3 A, RMS motor current is 1.5 A, and a 0.2-Ω sense resistor is used, the resistor dissipates $1.5 A^2 \times 0.2 \Omega = 0.45 W$. The power quickly increases with higher current levels.

Resistors typically have a rated power within some ambient temperature range, along with a derated power curve for high ambient temperatures. When a PCB is shared with other components generating heat, the system designer should add margin. It is always best to measure the actual sense resistor temperature in a final system.

Because power resistors are larger and more expensive than standard resistors, multiple standard resistors can be used in parallel, between the sense node and ground. This configuration distributes the current and heat dissipation.

8.2.3 Application Curves

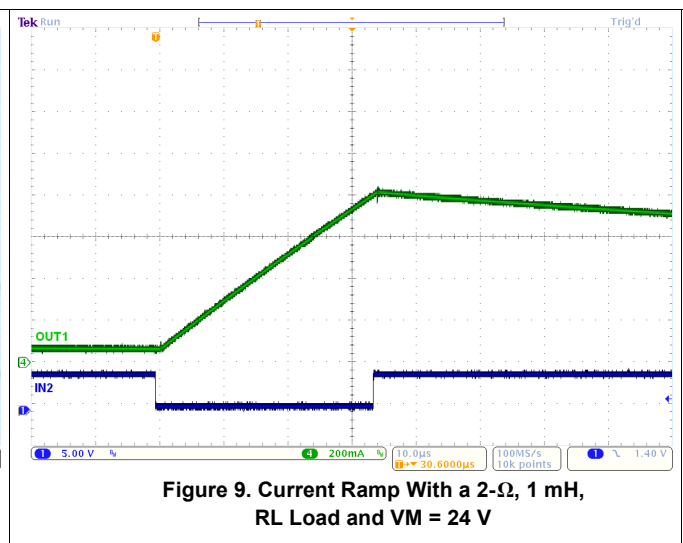
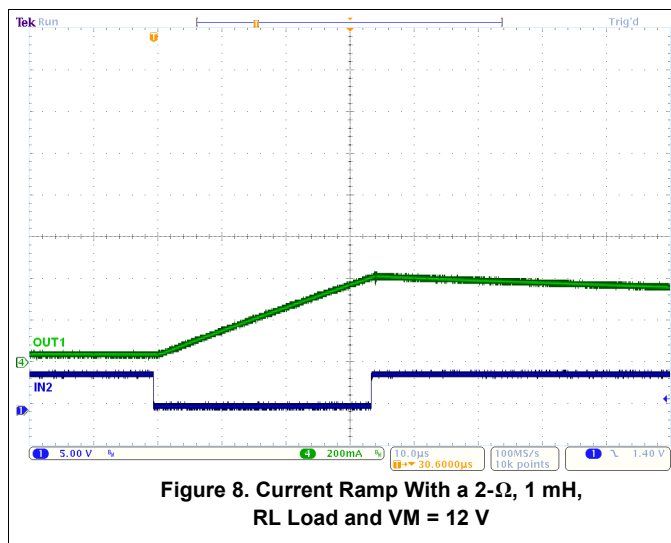

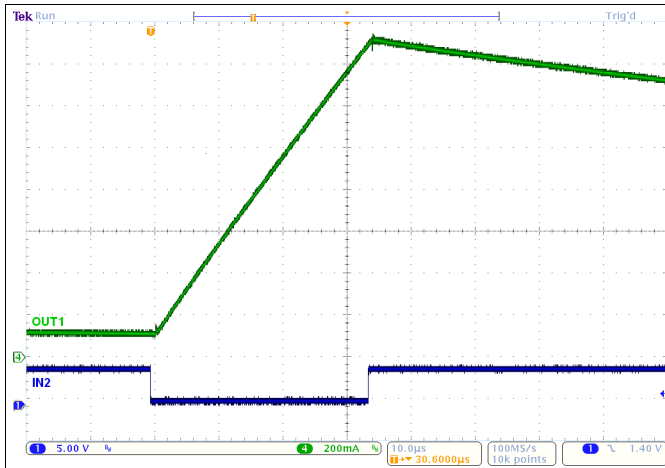

Figure 10. Current Ramp With a 2-Ω, 1 mH, RL Load and VM = 45 V

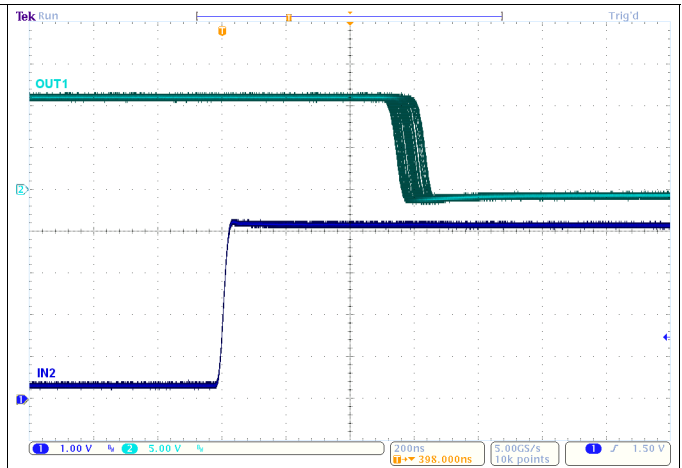

Figure 11. t_{pD}

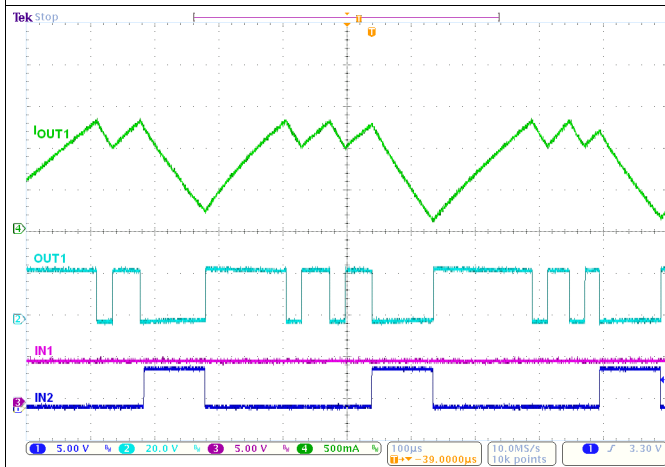

Figure 12. Current Regulation With $R_{SENSE} = 0.26 \Omega$

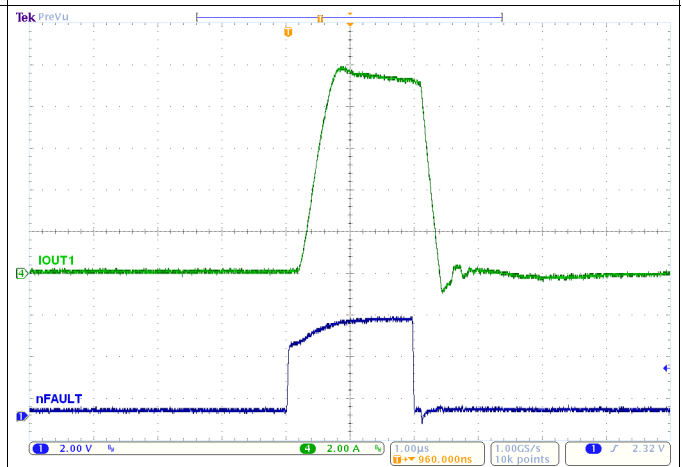

Figure 13. OCP With 24 V and Outputs Shorted Together

9 Power Supply Recommendations

9.1 Bulk Capacitance

Having appropriate local bulk capacitance is an important factor in motor drive system design. More bulk capacitance is generally beneficial but with the disadvantages of increased cost and physical size.

The amount of local capacitance needed depends on a variety of factors, including:

- The highest current required by the motor system
- The power supply's capacitance and ability to source current
- The amount of parasitic inductance between the power supply and motor system
- The acceptable voltage ripple
- The type of motor used (brushed DC, brushless DC, stepper)
- The motor braking method

The inductance between the power supply and motor drive system limits the rate that the current can change from the power supply. If the local bulk capacitance is too small, the system responds to excessive current demands or dumps from the motor with a change in voltage. When adequate bulk capacitance is used, the motor voltage remains stable and high current can be quickly supplied.

The data sheet generally provides a recommended value, but system-level testing is required to determine the appropriate sized bulk capacitor.

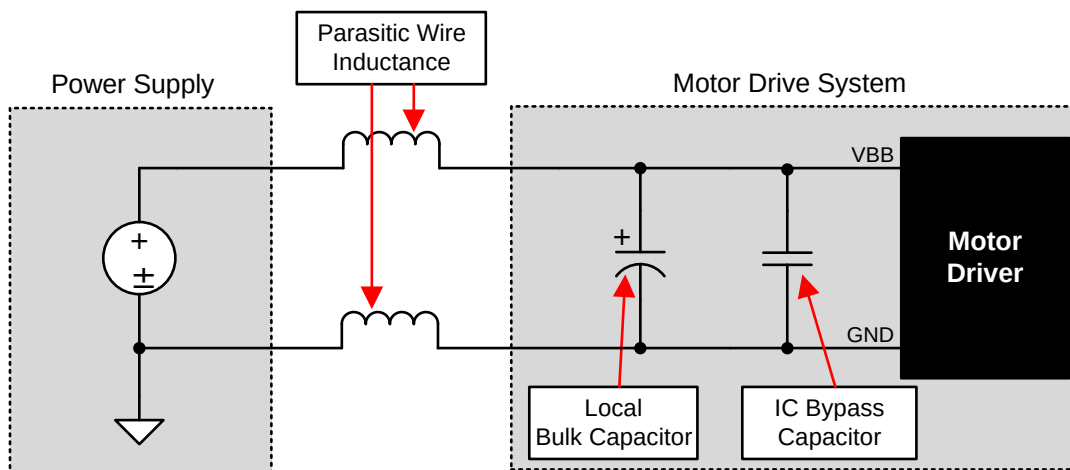

Figure 14. Example Setup of Motor Drive System With External Power Supply

The voltage rating for bulk capacitors should be higher than the operating voltage, to provide margin for cases when the motor transfers energy to the supply.

10 Layout

10.1 Layout Guidelines

The bulk capacitor should be placed to minimize the distance of the high-current path through the motor driver device. The connecting metal trace widths should be as wide as possible, and numerous vias should be used when connecting PCB layers. These practices minimize inductance and allow the bulk capacitor to deliver high current.

Small-value capacitors should be ceramic, and placed closely to device pins.

The high-current device outputs should use wide metal traces.

The device thermal pad should be soldered to the PCB top-layer ground plane. Multiple vias should be used to connect to a large bottom-layer ground plane. The use of large metal planes and multiple vias help dissipate the $I^2 \times R_{DS(on)}$ heat that is generated in the device.

Figure 15 shows the recommended layout and component placement.

10.2 Layout Example

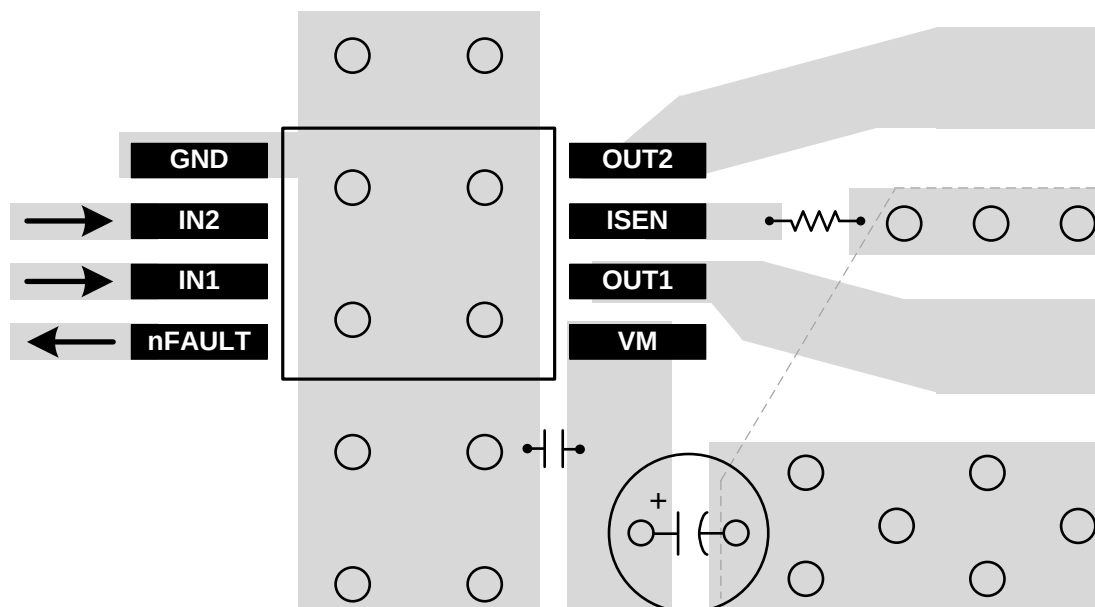

Figure 15. Layout Recommendation

10.3 Thermal Considerations

The DRV8872-Q1 device has thermal shutdown (TSD) as described in the [Thermal Shutdown \(TSD\)](#) section. If the die temperature exceeds approximately 175°C, the device is disabled until the temperature drops below the temperature hysteresis level.

Any tendency of the device to enter TSD is an indication of either excessive power dissipation, insufficient heatsinking, or too high of an ambient temperature.

10.4 Power Dissipation

Power dissipation in the DRV8872-Q1 device is dominated by the power dissipated in the output FET resistance, $R_{DS(on)}$. Use [Equation 2](#) from the [Drive Current](#) section to calculate the estimated average power dissipation of when driving a load.

Note that at startup, the output current is much higher than normal running current; this peak current and its duration must be also be considered.

Power Dissipation (continued)

The maximum amount of power that can be dissipated in the device is dependent on ambient temperature and heatsinking.

NOTE

$R_{DS(on)}$ increases with temperature, so as the device heats, the power dissipation increases. This fact must be taken into consideration when sizing the heatsink.

The power dissipation of the DRV8872-Q1 is a function of RMS motor current and the FET resistance ($R_{DS(ON)}$) of each output.

$$\text{Power} = I_{RMS}^2 \times (\text{High-side } R_{DS(ON)} + \text{Low-side } R_{DS(ON)}) \quad (3)$$

For this example, the ambient temperature is 58°C, and the junction temperature reaches 80°C. At 58°C, the sum of $R_{DS(ON)}$ is about 0.72 Ω. With an example motor current of 0.8 A, the dissipated power in the form of heat is $0.8 \text{ A}^2 \times 0.72 \text{ } \Omega = 0.46 \text{ W}$.

The temperature that the DRV8872-Q1 reaches depends on the thermal resistance to the air and PCB. Soldering the device PowerPAD to the PCB ground plane, with vias to the top and bottom board layers, is important to dissipate heat into the PCB and reduce the device temperature. In the example used here, the DRV8872-Q1 had an effective thermal resistance $R_{\theta JA}$ of 48°C/W, and a T_J value as shown in Equation 4.

$$T_J = T_A + (P_D \times R_{TJA}) = 58^\circ\text{C} + (0.46 \text{ W} \times 48 \text{ } ^\circ\text{C/W}) = 80^\circ\text{C} \quad (4)$$

10.4.1 Heatsinking

The PowerPAD package uses an exposed pad to remove heat from the device. For proper operation, this pad must be thermally connected to copper on the PCB to dissipate heat. On a multi-layer PCB with a ground plane, this connection can be accomplished by adding a number of vias to connect the thermal pad to the ground plane.

On PCBs without internal planes, a copper area can be added on either side of the PCB to dissipate heat. If the copper area is on the opposite side of the PCB from the device, thermal vias are used to transfer the heat between top and bottom layers.

For details about how to design the PCB, refer to the TI application report, [PowerPAD™ Thermally Enhanced Package](#) (SLMA002), and the TI application brief, [PowerPAD Made Easy™](#) (SLMA004), available at www.ti.com. In general, the more copper area that can be provided, the more power can be dissipated.

11 Device and Documentation Support

11.1 Documentation Support

11.1.1 Related Documentation

For related documentation, see the following:

- [Current Recirculation and Decay Modes](#) (SLVA321)
- [Calculating Motor Driver Power Dissipation](#) (SLVA504)
- [Operating an Engine-Grille Shutter Motor With DRV8872-Q1](#) (SLVA858)
- [PowerPAD™ Thermally Enhanced Package](#) (SLMA002)
- [PowerPAD™ Made Easy](#) (SLMA004)
- [Understanding Motor Driver Current Ratings](#) (SLVA505)

11.2 Receiving Notification of Documentation Updates

To receive notification of documentation updates, navigate to the device product folder on ti.com. In the upper right corner, click on *Alert me* to register and receive a weekly digest of any product information that has changed. For change details, review the revision history included in any revised document.

11.3 Community Resources

The following links connect to TI community resources. Linked contents are provided "AS IS" by the respective contributors. They do not constitute TI specifications and do not necessarily reflect TI's views; see TI's [Terms of Use](#).

TI E2E™ Online Community *TI's Engineer-to-Engineer (E2E) Community*. Created to foster collaboration among engineers. At e2e.ti.com, you can ask questions, share knowledge, explore ideas and help solve problems with fellow engineers.

Design Support *TI's Design Support* Quickly find helpful E2E forums along with design support tools and contact information for technical support.

11.4 Trademarks

PowerPAD, E2E are trademarks of Texas Instruments.
All other trademarks are the property of their respective owners.

11.5 Electrostatic Discharge Caution



This integrated circuit can be damaged by ESD. Texas Instruments recommends that all integrated circuits be handled with appropriate precautions. Failure to observe proper handling and installation procedures can cause damage.

ESD damage can range from subtle performance degradation to complete device failure. Precision integrated circuits may be more susceptible to damage because very small parametric changes could cause the device not to meet its published specifications.

11.6 Glossary

[SLYZ022](#) — *TI Glossary*.

This glossary lists and explains terms, acronyms, and definitions.

12 Mechanical, Packaging, and Orderable Information

The following pages include mechanical, packaging, and orderable information. This information is the most current data available for the designated devices. This data is subject to change without notice and revision of this document. For browser-based versions of this data sheet, refer to the left-hand navigation.

PACKAGING INFORMATION

Orderable Device	Status (1)	Package Type	Package Drawing	Pins	Package Qty	Eco Plan (2)	Lead/Ball Finish (6)	MSL Peak Temp (3)	Op Te
DRV8872DDARQ1	ACTIVE	SO PowerPAD	DDA	8	2500	Green (RoHS & no Sb/Br)	CU NIPDAUAG	Level-3-260C-168 HR	-40 t

(1) The marketing status values are defined as follows:

ACTIVE: Product device recommended for new designs.

LIFEBUY: TI has announced that the device will be discontinued, and a lifetime-buy period is in effect.

NRND: Not recommended for new designs. Device is in production to support existing customers, but TI does not recommend using this part in a new design.

PREVIEW: Device has been announced but is not in production. Samples may or may not be available.

OBSOLETE: TI has discontinued the production of the device.

(2) **RoHS:** TI defines "RoHS" to mean semiconductor products that are compliant with the current EU RoHS requirements for all 10 RoHS substances, including those that do not exceed 0.1% by weight in homogeneous materials. Where designed to be soldered at high temperatures, "RoHS" products are suitable for use in specified applications. For more information, see the TI website link below. TI does not recommend using these types of products as "Pb-Free".

RoHS Exempt: TI defines "RoHS Exempt" to mean products that contain lead but are compliant with EU RoHS pursuant to a specific EU RoHS exemption.

Green: TI defines "Green" to mean the content of Chlorine (Cl) and Bromine (Br) based flame retardants meet JS709B low halogen requirements of <=1000ppm threshold requirement. Flame retardants must also meet the <=1000ppm threshold requirement.

(3) MSL, Peak Temp. - The Moisture Sensitivity Level rating according to the JEDEC industry standard classifications, and peak solder temperature.

(4) There may be additional marking, which relates to the logo, the lot trace code information, or the environmental category on the device.

(5) Multiple Device Markings will be inside parentheses. Only one Device Marking contained in parentheses and separated by a "~" will appear on a device. If a line appears to the left of the previous line and the two combined represent the entire Device Marking for that device.

(6) Lead/Ball Finish - Orderable Devices may have multiple material finish options. Finish options are separated by a vertical ruled line. Lead/Ball Finish values may vary by device and may not be visible on all devices. If a value exceeds the maximum column width.

Important Information and Disclaimer: The information provided on this page represents TI's knowledge and belief as of the date that it is provided. TI bases its information on information provided by third parties, and makes no representation or warranty as to the accuracy of such information. Efforts are underway to better integrate information from third parties and TI continues to take reasonable steps to provide representative and accurate information but may not have conducted destructive testing or chemical analysis on all TI and TI suppliers consider certain information to be proprietary, and thus CAS numbers and other limited information may not be available for release.

In no event shall TI's liability arising out of such information exceed the total purchase price of the TI part(s) at issue in this document sold by TI to Customer on an as-shown basis.

OTHER QUALIFIED VERSIONS OF DRV8872-Q1 :

- Catalog: [DRV8872](#)

NOTE: Qualified Version Definitions:

- Catalog - TI's standard catalog product

TAPE AND REEL INFORMATION

QUADRANT ASSIGNMENTS FOR PIN 1 ORIENTATION IN TAPE

*All dimensions are nominal

Device	Package Type	Package Drawing	Pins	SPQ	Reel Diameter (mm)	Reel Width W1 (mm)	A0 (mm)	B0 (mm)	K0 (mm)	P1 (mm)	W (mm)	Pin1 Quadrant
DRV8872DDARQ1	SO Power PAD	DDA	8	2500	330.0	12.8	6.4	5.2	2.1	8.0	12.0	Q1

TAPE AND REEL BOX DIMENSIONS



*All dimensions are nominal

Device	Package Type	Package Drawing	Pins	SPQ	Length (mm)	Width (mm)	Height (mm)
DRV8872DDARQ1	SO PowerPAD	DDA	8	2500	366.0	364.0	50.0



Images above are just a representation of the package family, actual package may vary.
Refer to the product data sheet for package details.

DDA (R-PDSO-G8)

PowerPAD™ PLASTIC SMALL-OUTLINE

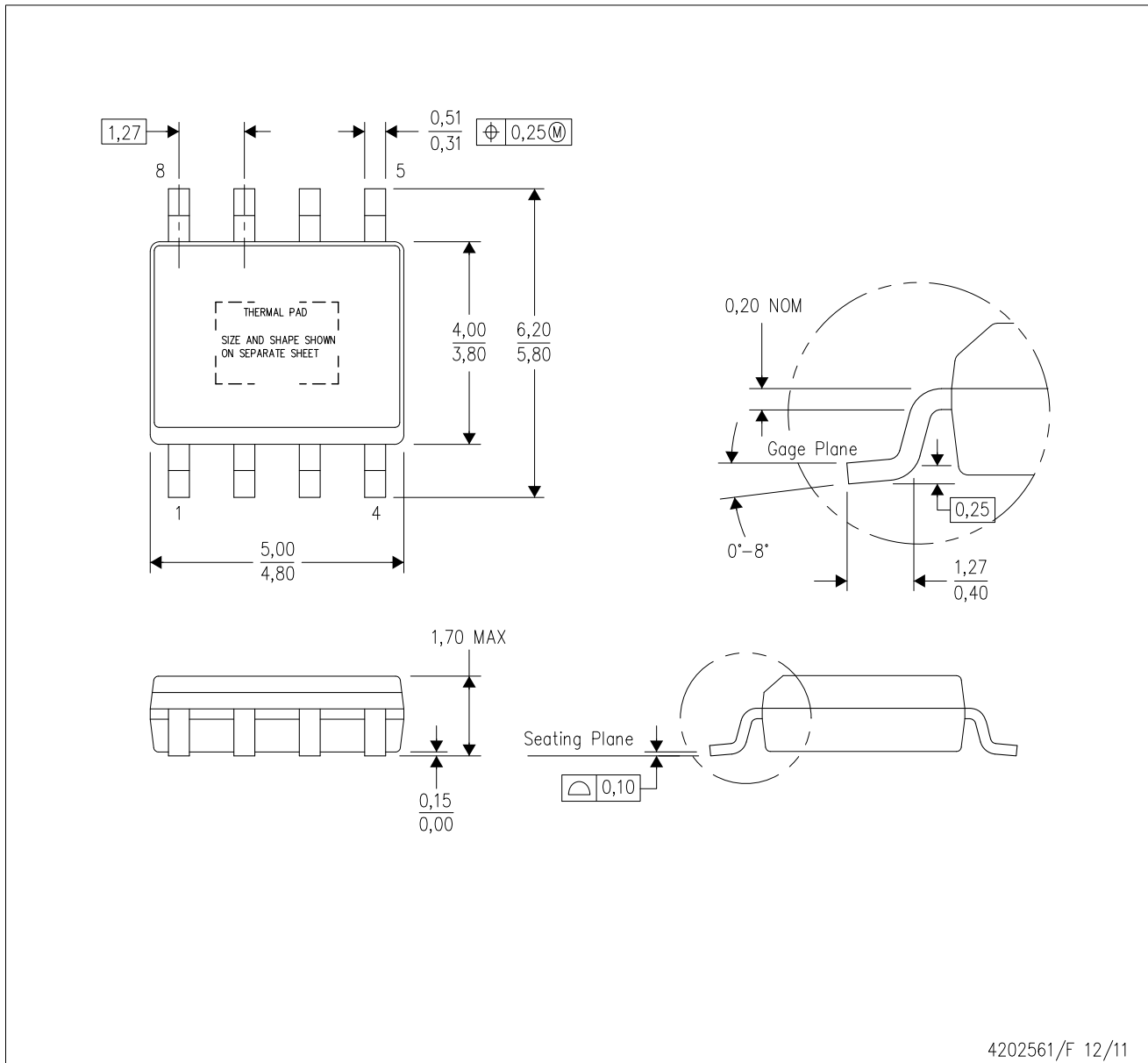

4202561/F 12/11

- NOTES:
- All linear dimensions are in millimeters. Dimensioning and tolerancing per ASME Y14.5-1994.
 - This drawing is subject to change without notice.
 - Body dimensions do not include mold flash or protrusion not to exceed 0,15.
 - This package is designed to be soldered to a thermal pad on the board. Refer to Technical Brief, PowerPad Thermally Enhanced Package, Texas Instruments Literature No. SLMA002 for information regarding recommended board layout. This document is available at www.ti.com <<http://www.ti.com>>.
 - See the additional figure in the Product Data Sheet for details regarding the exposed thermal pad features and dimensions.
 - This package complies to JEDEC MS-012 variation BA

PowerPAD is a trademark of Texas Instruments.

DDA (R-PDSO-G8)

PowerPAD™ PLASTIC SMALL OUTLINE

THERMAL INFORMATION

This PowerPAD™ package incorporates an exposed thermal pad that is designed to be attached to a printed circuit board (PCB). The thermal pad must be soldered directly to the PCB. After soldering, the PCB can be used as a heatsink. In addition, through the use of thermal vias, the thermal pad can be attached directly to the appropriate copper plane shown in the electrical schematic for the device, or alternatively, can be attached to a special heatsink structure designed into the PCB. This design optimizes the heat transfer from the integrated circuit (IC).

For additional information on the PowerPAD package and how to take advantage of its heat dissipating abilities, refer to Technical Brief, PowerPAD Thermally Enhanced Package, Texas Instruments Literature No. SLMA002 and Application Brief, PowerPAD Made Easy, Texas Instruments Literature No. SLMA004. Both documents are available at www.ti.com.

The exposed thermal pad dimensions for this package are shown in the following illustration.

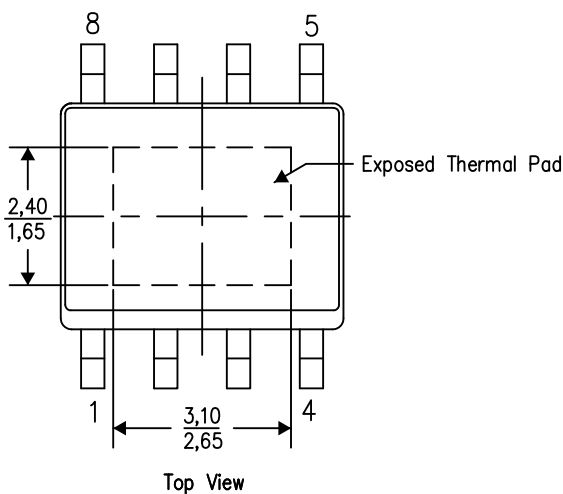

Exposed Thermal Pad Dimensions

4206322-6/L 05/12

NOTE: A. All linear dimensions are in millimeters

PowerPAD is a trademark of Texas Instruments

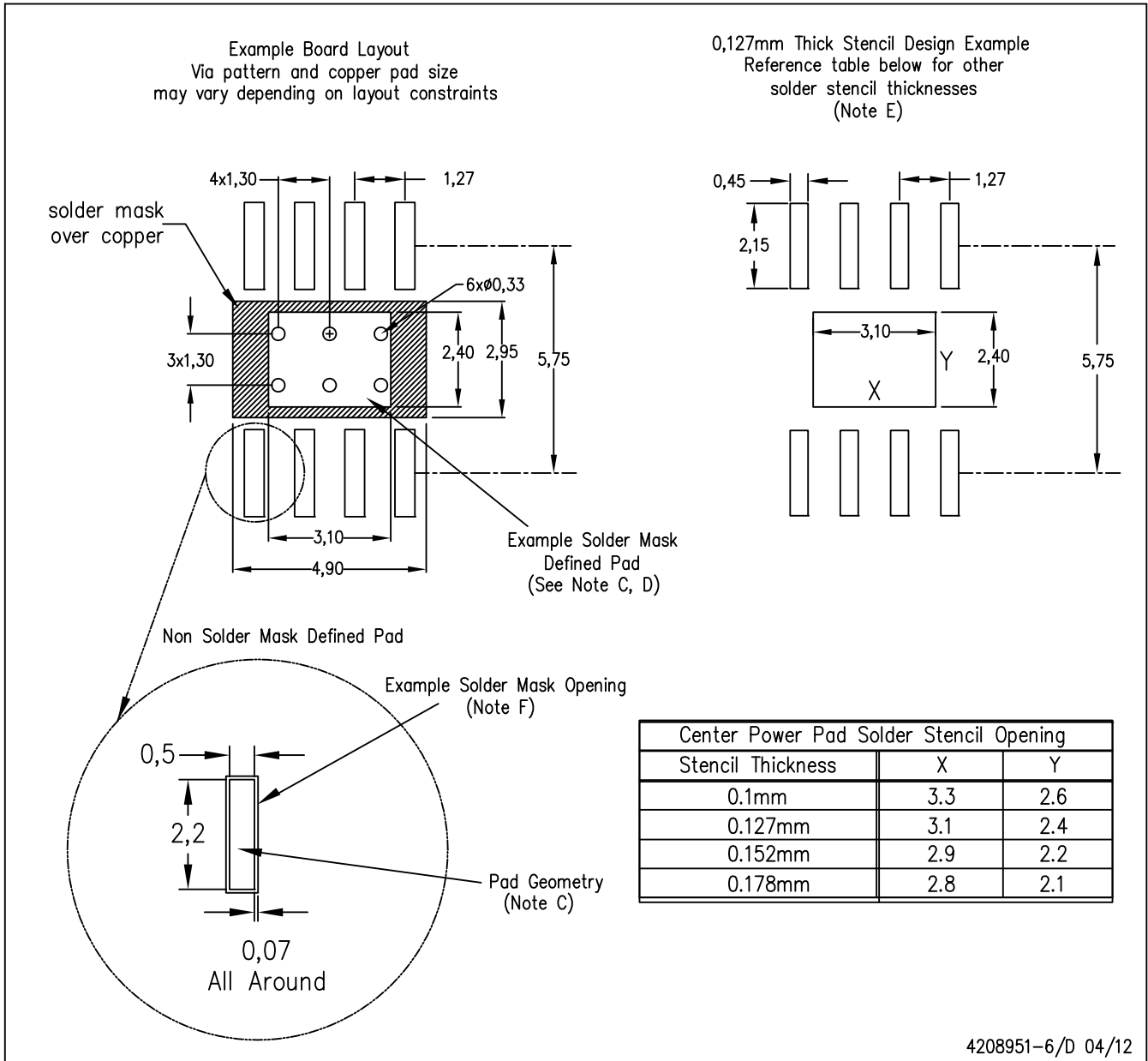

- NOTES:
- A. All linear dimensions are in millimeters.
 - B. This drawing is subject to change without notice.
 - C. Publication IPC-7351 is recommended for alternate designs.
 - D. This package is designed to be soldered to a thermal pad on the board. Refer to Technical Brief, PowerPAD Thermally Enhanced Package, Texas Instruments Literature No. SLMA002, SLMA004, and also the Product Data Sheets for specific thermal information, via requirements, and recommended board layout. These documents are available at www.ti.com <<http://www.ti.com>>. Publication IPC-7351 is recommended for alternate designs.
 - E. Laser cutting apertures with trapezoidal walls and also rounding corners will offer better paste release. Customers should contact their board assembly site for stencil design recommendations. Example stencil design based on a 50% volumetric metal load solder paste. Refer to IPC-7525 for other stencil recommendations.
 - F. Customers should contact their board fabrication site for solder mask tolerances between and around signal pads.

PowerPAD is a trademark of Texas Instruments.

IMPORTANT NOTICE

Texas Instruments Incorporated (TI) reserves the right to make corrections, enhancements, improvements and other changes to its semiconductor products and services per JESD46, latest issue, and to discontinue any product or service per JESD48, latest issue. Buyers should obtain the latest relevant information before placing orders and should verify that such information is current and complete.

TI's published terms of sale for semiconductor products (<http://www.ti.com/sc/docs/stdterms.htm>) apply to the sale of packaged integrated circuit products that TI has qualified and released to market. Additional terms may apply to the use or sale of other types of TI products and services.

Reproduction of significant portions of TI information in TI data sheets is permissible only if reproduction is without alteration and is accompanied by all associated warranties, conditions, limitations, and notices. TI is not responsible or liable for such reproduced documentation. Information of third parties may be subject to additional restrictions. Resale of TI products or services with statements different from or beyond the parameters stated by TI for that product or service voids all express and any implied warranties for the associated TI product or service and is an unfair and deceptive business practice. TI is not responsible or liable for any such statements.

Buyers and others who are developing systems that incorporate TI products (collectively, "Designers") understand and agree that Designers remain responsible for using their independent analysis, evaluation and judgment in designing their applications and that Designers have full and exclusive responsibility to assure the safety of Designers' applications and compliance of their applications (and of all TI products used in or for Designers' applications) with all applicable regulations, laws and other applicable requirements. Designer represents that, with respect to their applications, Designer has all the necessary expertise to create and implement safeguards that (1) anticipate dangerous consequences of failures, (2) monitor failures and their consequences, and (3) lessen the likelihood of failures that might cause harm and take appropriate actions. Designer agrees that prior to using or distributing any applications that include TI products, Designer will thoroughly test such applications and the functionality of such TI products as used in such applications.

TI's provision of technical, application or other design advice, quality characterization, reliability data or other services or information, including, but not limited to, reference designs and materials relating to evaluation modules, (collectively, "TI Resources") are intended to assist designers who are developing applications that incorporate TI products; by downloading, accessing or using TI Resources in any way, Designer (individually or, if Designer is acting on behalf of a company, Designer's company) agrees to use any particular TI Resource solely for this purpose and subject to the terms of this Notice.

TI's provision of TI Resources does not expand or otherwise alter TI's applicable published warranties or warranty disclaimers for TI products, and no additional obligations or liabilities arise from TI providing such TI Resources. TI reserves the right to make corrections, enhancements, improvements and other changes to its TI Resources. TI has not conducted any testing other than that specifically described in the published documentation for a particular TI Resource.

Designer is authorized to use, copy and modify any individual TI Resource only in connection with the development of applications that include the TI product(s) identified in such TI Resource. NO OTHER LICENSE, EXPRESS OR IMPLIED, BY ESTOPPEL OR OTHERWISE TO ANY OTHER TI INTELLECTUAL PROPERTY RIGHT, AND NO LICENSE TO ANY TECHNOLOGY OR INTELLECTUAL PROPERTY RIGHT OF TI OR ANY THIRD PARTY IS GRANTED HEREIN, including but not limited to any patent right, copyright, mask work right, or other intellectual property right relating to any combination, machine, or process in which TI products or services are used. Information regarding or referencing third-party products or services does not constitute a license to use such products or services, or a warranty or endorsement thereof. Use of TI Resources may require a license from a third party under the patents or other intellectual property of the third party, or a license from TI under the patents or other intellectual property of TI.

TI RESOURCES ARE PROVIDED "AS IS" AND WITH ALL FAULTS. TI DISCLAIMS ALL OTHER WARRANTIES OR REPRESENTATIONS, EXPRESS OR IMPLIED, REGARDING RESOURCES OR USE THEREOF, INCLUDING BUT NOT LIMITED TO ACCURACY OR COMPLETENESS, TITLE, ANY EPIDEMIC FAILURE WARRANTY AND ANY IMPLIED WARRANTIES OF MERCHANTABILITY, FITNESS FOR A PARTICULAR PURPOSE, AND NON-INFRINGEMENT OF ANY THIRD PARTY INTELLECTUAL PROPERTY RIGHTS. TI SHALL NOT BE LIABLE FOR AND SHALL NOT DEFEND OR INDEMNIFY DESIGNER AGAINST ANY CLAIM, INCLUDING BUT NOT LIMITED TO ANY INFRINGEMENT CLAIM THAT RELATES TO OR IS BASED ON ANY COMBINATION OF PRODUCTS EVEN IF DESCRIBED IN TI RESOURCES OR OTHERWISE. IN NO EVENT SHALL TI BE LIABLE FOR ANY ACTUAL, DIRECT, SPECIAL, COLLATERAL, INDIRECT, PUNITIVE, INCIDENTAL, CONSEQUENTIAL OR EXEMPLARY DAMAGES IN CONNECTION WITH OR ARISING OUT OF TI RESOURCES OR USE THEREOF, AND REGARDLESS OF WHETHER TI HAS BEEN ADVISED OF THE POSSIBILITY OF SUCH DAMAGES.

Unless TI has explicitly designated an individual product as meeting the requirements of a particular industry standard (e.g., ISO/TS 16949 and ISO 26262), TI is not responsible for any failure to meet such industry standard requirements.

Where TI specifically promotes products as facilitating functional safety or as compliant with industry functional safety standards, such products are intended to help enable customers to design and create their own applications that meet applicable functional safety standards and requirements. Using products in an application does not by itself establish any safety features in the application. Designers must ensure compliance with safety-related requirements and standards applicable to their applications. Designer may not use any TI products in life-critical medical equipment unless authorized officers of the parties have executed a special contract specifically governing such use. Life-critical medical equipment is medical equipment where failure of such equipment would cause serious bodily injury or death (e.g., life support, pacemakers, defibrillators, heart pumps, neurostimulators, and implantables). Such equipment includes, without limitation, all medical devices identified by the U.S. Food and Drug Administration as Class III devices and equivalent classifications outside the U.S.

TI may expressly designate certain products as completing a particular qualification (e.g., Q100, Military Grade, or Enhanced Product). Designers agree that it has the necessary expertise to select the product with the appropriate qualification designation for their applications and that proper product selection is at Designers' own risk. Designers are solely responsible for compliance with all legal and regulatory requirements in connection with such selection.

Designer will fully indemnify TI and its representatives against any damages, costs, losses, and/or liabilities arising out of Designer's non-compliance with the terms and provisions of this Notice.