

AN7411

FM Stereo Multiplex Demodulator

■ Description

The AN7411 is a monolithic integrated circuit designed for low voltage operating FM multiplex demodulator.

■ Features

- LED mis-tuning protection circuit at transient operation voltage
- High performance (small gain loss, low distortion)
- Provided with forced monaural and VCO stop circuits
- Wide operating supply voltage: $V_{CC} = 3.6V \sim 14.4V$

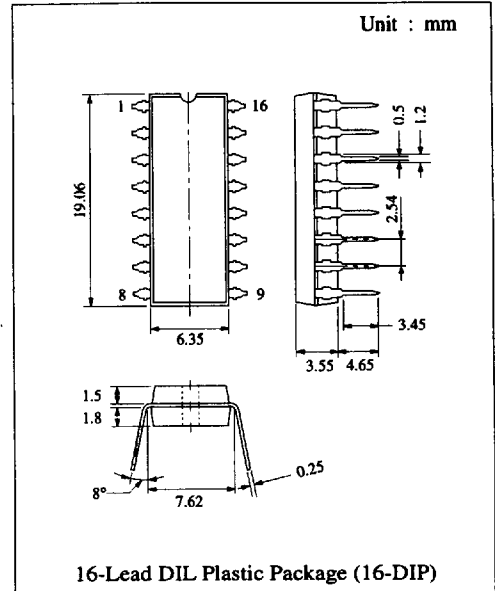

■ Block Diagram

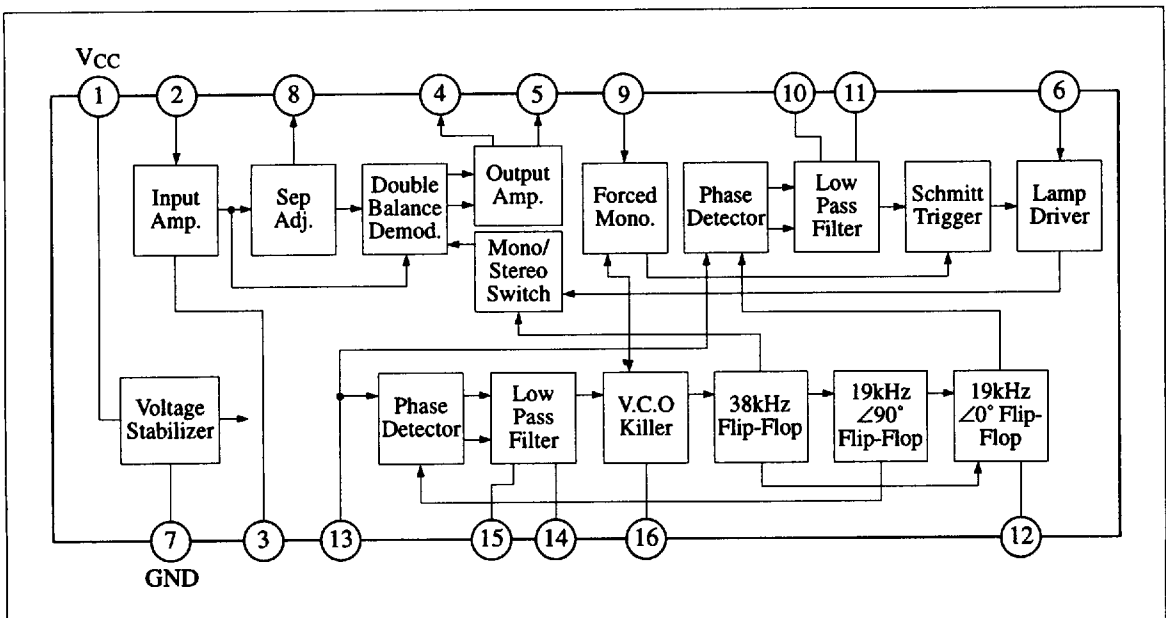

■ Absolute Maximum Ratings (Ta=25°C)

Item	Symbol	Rating	Unit
Supply Voltage	V _{CC}	14.4	V
Terminal Voltage	V ₆₋₇	14.4	V
Circuit Current	I _G	75	mA
Power Dissipation	P _D	360	mW
Operating Ambient Temperature	Topr	-20 ~ +75	°C
Storage Temperature	Tstg	-55 ~ +125	°C

Operating Supply Voltage Range: V_{CC} = 3.6V ~ 14.4V

■ Electrical Characteristics (V_{CC}=6V, Ta=25°C)

Item	Symbol	Condition	min.	typ.	max.	Unit
Total Current	I _{tot}	V _{in} = 0mV	9	13	17	mA
Separation	Sep	V _(L+R) = 135mV, f _m = 1kHz,	30	45		dB
Total Harmonic Distortion (Stereo)	THD	V _p = 15mV		0.07	0.3	%
Total Harmonic Distortion (Monaural)	THD			0.07	0.3	%
Output Voltage(Monaural)	V _O	V _{in} = 150mV, f _m = 1kHz	135	155	180	mV
Channel Balance(Monaural)	CB		-1	0	+1	dB
Stereo Lamp ON Level	V _{p(ON)}	Pilot signal (19kHz)	3.5	5.5	7.5	mV

Test Circuit (De-emphasis: approximately 75μs)

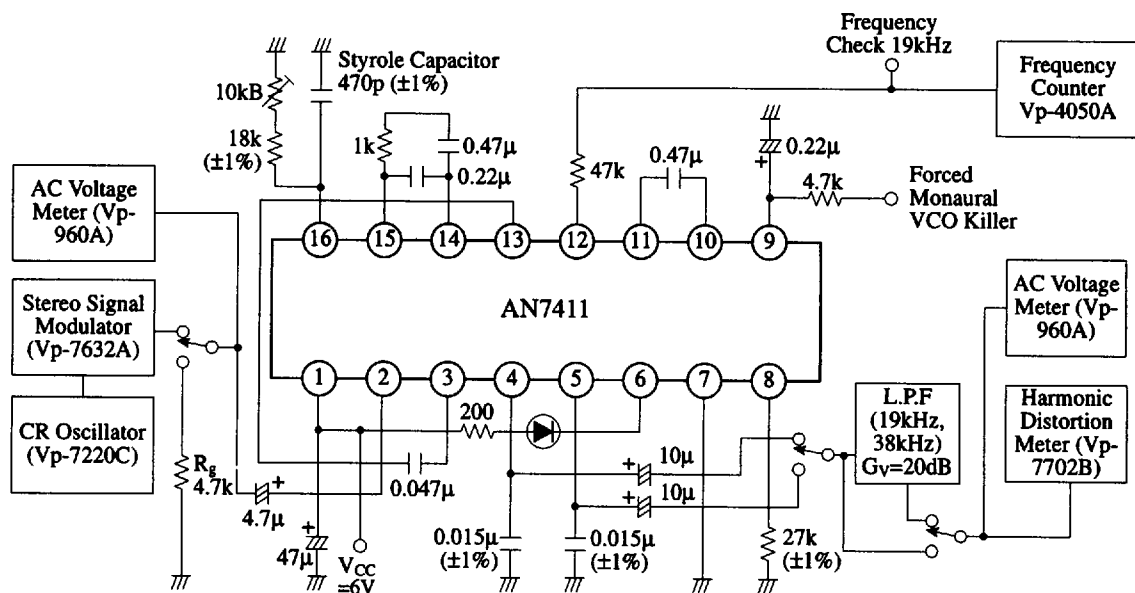

Note 1) VCO free-run frequency is adjusted to 19kHz (±10Hz) with frequency check terminal.

Note 2) Outer component should be in less than (±5%) unless otherwise specified.

L.P.F. (3L-13) is a filter amplifier with gain 20dB manufactured by Koringiken.

■ Application Circuit

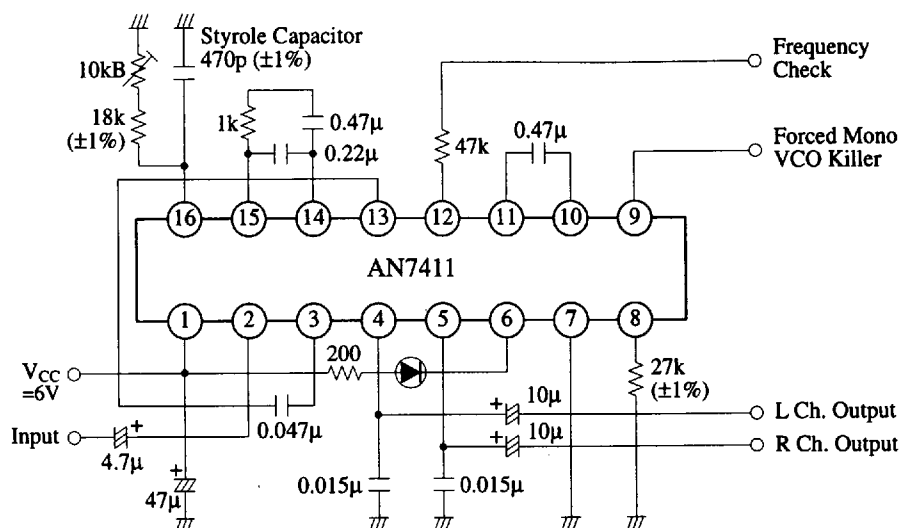

* Printed Circuit Board Layout please refer to AN7410N

■ Pin

Pin No	Pin Name	Notes
1	V _{CC}	Maximum V _{CC} 14.4V
2	Stereo Signal Input	Coupling capacitor 4.7µF (to front stage FM detector)
3	Input Buffer Amplifier Output	Coupling capacitor 0.047µF (between pin 3 and 13)
4	Left Channel Signal Output (Built-in Output Load Resistor 4.7kΩ)	Coupling capacitor 10µF (to next stage low frequency amplifier) De-emphasis capacitor 0.015µF (between pin 4 and GND)
5	Right Channel Signal Output (Built-in Output Load Resistor 4.7kΩ)	Coupling capacitor 10µF (to next stage low frequency amplifier) De-emphasis capacitor 0.015µF (between pin 5 and GND)
6	Drive Terminal for Stereo Display Lamp	Lamp or LED (maximum supply voltage 12V) (maximum drive current 75mA)
7	GND	
8	Channel Separation Adjusting	Fixed resistor 27kΩ (±1%) (between pin 8 and GND) Best separation value is obtained by using VR 50kΩ(B)
9	Emphasis Monaural VCO Emphasis Stop	Emphasis monaural operates at DC 0.9V (between pin 9 and GND) VCO stops oscillation at more than 1.5V
10	Stereo Switch Circuit Low Pass Filter	Low pass filter capacitor 0.47µF (between pin 10 and 11) (Capacitor with low leakage should be used)
11	Stereo Switch Circuit Low Pass Filter	Refer to pin 10
12	19kHz Frequency Check	Resistor 47kΩ (Protection resistor) (between pin 12 and frequency counter)
13	PLL Circuit Input	Refer to pin 3
14	PLL Circuit Low Pass Filter	Filter element 0.22µF // 0.47µF + 1kΩ (between pin 14 and 15) Condenser with low leakage current should be used.
15	PLL Circuit, Low Pass Filter	Refer to pin 14
16	VCO Frequency Adjustment.	Condenser 470pF (±1%) // (between pin 16 and GND) Carbon resistor 18kΩ (±1%) + VR10kΩ(B)

This datasheet has been download from:

www.datasheetcatalog.com

Datasheets for electronics components.