



## 16-Channel Constant Current LED Drive With 16-bit PWM Control and Dot-Correction

### Features

- 16 constant-current output channels
- Constant output current range per channel: 2~60mA
  - 2~60mA @ 5V supply voltage
  - 2~45mA @ 3.3V supply voltage
- Excellent output current accuracy,
  - Between channels:  $<\pm 1.5\%$  (typ.);
  - Between ICs:  $<\pm 3\%$  (typ.)
- Visual effect control
  - Patented S-PWM technology to improve refresh rate
  - 16-bit or 12-bit gray scale control
  - 8-bit dot-correction
  - 7-bit linear programmable output current gain
- Error detection control
  - In-message error detection:  
on-the-fly, data-in error-out
  - Compulsory individual LED open/short-circuit detection:  
full panel, data independent  
silent error detection in 700ns
  - Configurable short-circuit detection threshold voltage
  - Thermal protection
- Flexible operation modes
  - Auto synchronization mode/manual synchronization mode
  - One-shot mode/continuous mode
  - Disable/enable command
- EMI reduction
  - Staggered delay of output, preventing from current surge
  - Selectable switching speed of output channels ( $t_{OR}$ ,  $t_{OF}$ )
- Maximum data clock frequency: 30MHz
- Maximum gray scale clock frequency: 33MHz
- Schmitt trigger input
- Backward compatible with MBI5026 and MBI5030 in package

#### Small Outline Package

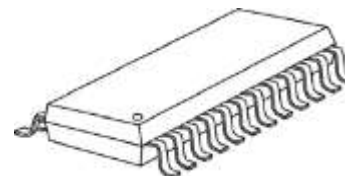

GF: SOP24L-300-1.00

#### Thin Shrink SOP

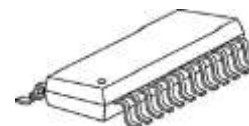

GTS: TSSOP24L-173-0.65

#### QFN

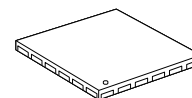

GFN: QFN24L-4\*4-0.5

### Application

- Full-color LED display

## With 16-Bit PWM Control and Dot-Correction

### Product Description

MBI5040 is a 16-channel constant current LED driver with selectable 16-/12-bit gray scale control and 8-bit dot correction. MBI5040 provides constant current ranging from 2mA to 60mA for each output channel. The output current can be set by an external resistor. MBI5040 adopts **Share-I-O™** technology to be backward compatible with MBI5026 and MBI5030 in package and to extend the functionality, such as in-message error detection, compulsory error detection, thermal protection, and current gain control in LED display systems.

With Scrambled-PWM (S-PWM) technology, MBI5040 enhances pulse width modulation by scrambling the 'on' time into several 'on' periods, so that MBI5040 is able to increase visual refresh rate and reduce flickers. In addition, MBI5040 provides 16-bit gray scale control to enrich the color of image, allowing to present video images with 65,536 gray scales. MBI5040 also provides 8-bit dot correction to individually calibrate the deviated brightness and color of LEDs. Moreover, the preset current of MBI5040 can be further adjusted by 128 steps for LED global brightness adjustment.

With in-message error detection, MBI5040 can detect individual LED for both open- and short-circuit errors on-the-fly without extra components. Additionally, to enhance the system reliability, MBI5040 is built with thermal protection functions.

## With 16-Bit PWM Control and Dot-Correction

### Pin Configuration

|      |    |    |       |
|------|----|----|-------|
| GND  | 1  | 24 | VDD   |
| SDI  | 2  | 23 | R-EXT |
| DCLK | 3  | 22 | SDO   |
| LE   | 4  | 21 | GCLK  |
| OUT0 | 5  | 20 | OUT15 |
| OUT1 | 6  | 19 | OUT14 |
| OUT2 | 7  | 18 | OUT13 |
| OUT3 | 8  | 17 | OUT12 |
| OUT4 | 9  | 16 | OUT11 |
| OUT5 | 10 | 15 | OUT10 |
| OUT6 | 11 | 14 | OUT9  |
| OUT7 | 12 | 13 | OUT8  |

MBI5040GF/GP/GTS

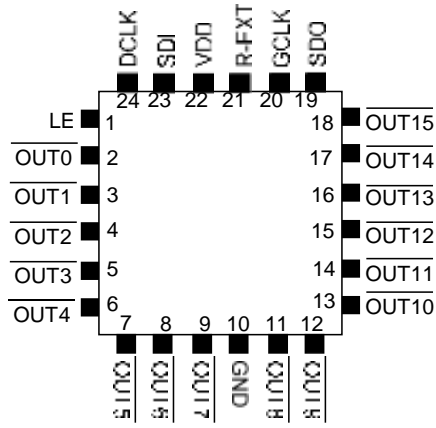

MBI5040GFN

### Terminal Description

| Pin Name     | Function  |
|--------------|---|
| GND          | Ground terminal for control logic and current sink  |
| SDI          | Serial-data input to the shift register   |
| DCLK         | Clock input terminal used to shift data on rising edge and carries command information when LE is asserted.                               |
| LE           | Data strobe terminal and controlling command with DCLK  |
| OUT0 ~ OUT15 | Constant current output terminals   |
| GCLK         | Gray scale clock terminal<br>Clock input for gray scale. The gray scale display is counted by gray scale clock comparing with input data. |
| SDO          | Serial-data output to the SDI of next driver IC   |
| R-EXT        | Input terminal used to connect an external resistor for setting up output current for all output channels                                 |
| VDD          | 3.3V/5V supply voltage terminal   |

# With 16-Bit PWM Control and Dot-Correction

## Block Diagram

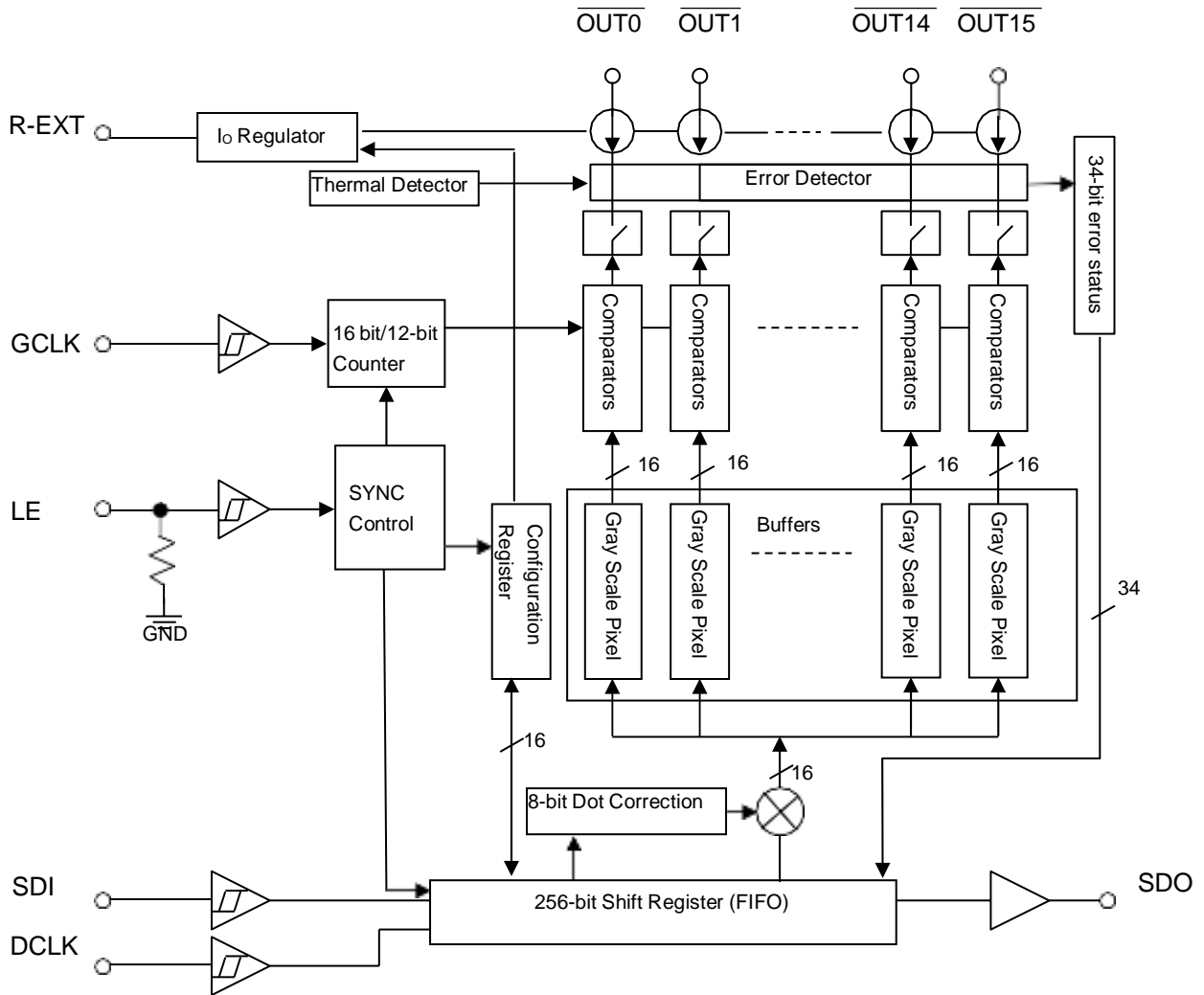

## With 16-Bit PWM Control and Dot-Correction

### Equivalent Circuits of Inputs and Outputs

**GCLK, DCLK, SDI terminal**

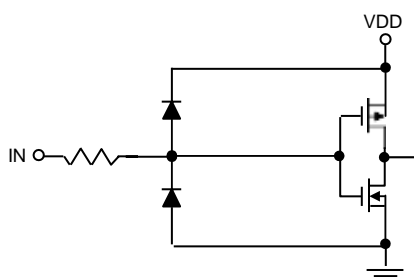

**LE terminal**

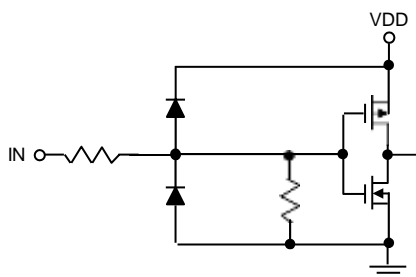

**SDO terminal**

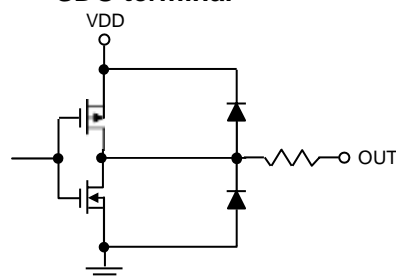

### Maximum Rating

| Characteristic   |  | Symbol        | Rating                             | Unit               |
|--|--|---------------|------------------------------------|--------------------|
| Supply Voltage   |  | $V_{DD}$      | 0~7                                | V                  |
| Input Pin Voltage (SDI, DCLK, LE, GCLK, R-EXT)             |  | $V_{IN}$      | -0.4~ $V_{DD}+0.4$                 | V                  |
| Output Current   |  | $I_{OUT}$     | +80                                | mA                 |
| Sustaining Voltage at OUT Port                             |  | $V_{DS}$      | -0.5~17                            | V                  |
| GND Terminal Current                                       |  | $I_{GND}$     | +1280                              | mA                 |
| Power Dissipation<br>(On PCB, $T_a=25^\circ\text{C}$ )*    | GF Type                                      | $P_D$         | 2.52                               | W                  |
|  | GTS Type                                     |               | 3.53                               |                    |
|  | GFN Type                                     |               | 3.13                               |                    |
| Thermal Resistance<br>(On PCB, $T_a=25^\circ\text{C}$ )*   | GF Type                                      | $R_{th(j-a)}$ | 49.69                              | $^\circ\text{C/W}$ |
|  | GTS Type                                     |               | 35.45                              |                    |
|  | GFN Type                                     |               | 40.01                              |                    |
| Empirical Thermal Resistance<br>( $T_a=25^\circ\text{C}$ ) | GF Type                                      | $R_{th(j-a)}$ | 78.83                              | $^\circ\text{C/W}$ |
|  | GTS Type                                     |               | 89.11                              |                    |
|  | GFN Type                                     |               | 94.25                              |                    |
| Junction Temperature                                       |  | $T_{j,max}$   | 150**                              | $^\circ\text{C}$   |
| Operating Ambient Temperature                              |  | $T_{opr}$     | -40~+85                            | $^\circ\text{C}$   |
| Storage Temperature  |  | $T_{stg}$     | -55~+150                           | $^\circ\text{C}$   |
| ESD Rating   | Human Body Mode (MIL-STD-883G Method 3015.7) | HBM           | Class 3<br>( $\geq 4000\text{V}$ ) | -                  |
|  | Machine Mode (JEDEC EIA/JESD22-A115,)        | MM            | Class M4<br>( $\geq 400\text{V}$ ) | -                  |

\*The PCB size is 76.2mm\*114.3mm in simulation. Please refer to JEDEC JESD51.

\*\* Operation at the maximum rating for extended periods may reduce the device reliability; therefore, the suggested junction temperature of the device is under 125 $^\circ\text{C}$ .

Note: The performance of thermal dissipation is strongly related to the size of thermal pad, thickness and layer numbers of the PCB. The empirical thermal resistance may be different from simulative value. User should plan for expected thermal dissipation performance by selecting package and arranging layout of the PCB to maximize the capability.

With 16-Bit PWM Control and Dot-Correction  
**Electrical Characteristics (V<sub>DD</sub>=5.0V, Ta=25 °C)**

| Characteristics                                       |                    | Symbol   | Condition  | Min.                 | Typ. | Max.                | Unit  |
|---|--------------------|--|--|----------------------|------|---------------------|-------|
| Supply Voltage  |                    | V <sub>DD</sub>  | -  | 4.5                  | 5.0  | 5.5                 | V     |
| Sustaining Voltage at OUT Ports                       |                    | V <sub>DS</sub>  | $\overline{\text{OUT0}} \sim \overline{\text{OUT15}}$                                      | -                    | -    | 17.0                | V     |
| Output Current  | I <sub>OUT</sub>   | Refer to "Test Circuit for Electrical Characteristics" |  | 2                    | -    | 60                  | mA    |
|   | I <sub>OH</sub>    | SDO  |  | -                    | -    | -1.0                | mA    |
|   | I <sub>OL</sub>    | SDO  |  | -                    | -    | 1.0                 | mA    |
| Output Leakage Current                                |                    | I <sub>OUT</sub>                                       | V <sub>DS</sub> =17.0V   | -                    | -    | 0.5μA               |       |
| Current Skew (Channel)                                | dl <sub>OUT</sub>  | I <sub>OUT</sub> =25.8mA<br>V <sub>DS</sub> =1.0V      | R <sub>ext</sub> =560Ω-  | ±1.5                 |      | ±3.0                | %     |
|   |                    | I <sub>OUT</sub> =45mA<br>V <sub>DS</sub> =1.0V        | R <sub>ext</sub> =310Ω-  | ±1.5                 |      | ±3.0                | %     |
| Current Skew (IC)                                     | dl <sub>OUT2</sub> | I <sub>OUT</sub> =25.8mA<br>V <sub>DS</sub> =1.0V      | R <sub>ext</sub> =560Ω-  | ±3.0                 |      | ±6.0                | %     |
|   |                    | I <sub>OUT</sub> =45mA<br>V <sub>DS</sub> =1.0V        | R <sub>ext</sub> =310Ω-  | ±3.0                 |      | ±6.0                | %     |
| Output Current vs. Output Voltage Regulation*         |                    | %/dV <sub>DS</sub>                                     | V <sub>DS</sub> within 1.0V and 3.0V,<br>R <sub>ext</sub> =560Ω@25.8mA                     | -                    | ±0.1 | ±0.5                | % / V |
| Output Current vs. Supply Voltage Regulation*         |                    | %/dV <sub>DD</sub>                                     | V <sub>DD</sub> within 4.5V and 5.5V   | -                    | ±0.5 | ±1.0                | % / V |
| Input Voltage of SDI, DCLK, LE, GCLK                  | "H" level          | V <sub>IH</sub>  | Ta=-40~85°C  | 0.7xV <sub>DD</sub>  | -    | V <sub>DD</sub>     | V     |
|   | "L" level          | V <sub>IL</sub>  | Ta=-40~85°C  | GND                  | -    | 0.3xV <sub>DD</sub> | V     |
| Output Voltage  | SDO                | V <sub>OH</sub>  | I <sub>OH</sub> =-1.0mA  | V <sub>DD</sub> -0.4 | -    | -                   | V     |
|   |                    | V <sub>OL</sub>  | I <sub>OL</sub> =+1.0mA  | -                    | -    | 0.4                 | V     |
| LED Open Error Detection Threshold                    |                    | V <sub>DS,TH</sub>                                     | -  | -                    | 0.30 | 0.35                | V     |
| Pull-down Resistor of LE                              |                    | R <sub>IN(down)</sub>                                  | -  | 250                  | 450  | 800                 | KΩ    |
| Supply Current (DCLK=GCLK=0Hz)                        | "Off"              | I <sub>DD(off) 1</sub>                                 | R <sub>ext</sub> =Open, $\overline{\text{OUT0}} \sim \overline{\text{OUT15}} = \text{Off}$ | -                    | 2.4  | 5                   | mA    |
|   |                    | I <sub>DD(off) 2</sub>                                 | R <sub>ext</sub> =560Ω, $\overline{\text{OUT0}} \sim \overline{\text{OUT15}} = \text{Off}$ | -                    | 6.5  | 10                  |       |
|   |                    | I <sub>DD(off) 3</sub>                                 | R <sub>ext</sub> =310Ω, $\overline{\text{OUT0}} \sim \overline{\text{OUT15}} = \text{Off}$ | -                    | 8.8  | 12                  |       |
|   | "On"               | I <sub>DD(on) 1</sub>                                  | R <sub>ext</sub> =560Ω, $\overline{\text{OUT0}} \sim \overline{\text{OUT15}} = \text{On}$  | -                    | 6.6  | 11                  |       |
|   |                    | I <sub>DD(on) 2</sub>                                  | R <sub>ext</sub> =310Ω, $\overline{\text{OUT0}} \sim \overline{\text{OUT15}} = \text{On}$  | -                    | 9.9  | 13                  |       |
| Supply Current (DCLK=GCLK=30MHz, SDI=15MHz switching) | "On"               | I <sub>DD(on) 1</sub>                                  | R <sub>ext</sub> =560Ω, $\overline{\text{OUT0}} \sim \overline{\text{OUT15}} = \text{On}$  | -                    | 23.0 | -                   |       |
|   |                    | I <sub>DD(on) 2</sub>                                  | R <sub>ext</sub> =310Ω, $\overline{\text{OUT0}} \sim \overline{\text{OUT15}} = \text{On}$  | -                    | 23.7 | -                   |       |
| Thermal Flag Temperature 1 **                         |                    | T <sub>TF1</sub>                                       | Junction Temperature   | -                    | 140  | -                   | °C    |
| Thermal Flag Temperature 2 **                         |                    | T <sub>TF2</sub>                                       | Junction Temperature   | -                    | 160  | -                   | °C    |

\*One channel on.

\*\*Thermal flag 1 is over-temperature alarm, and thermal flag 2 is thermal shutdown.

## With 16-Bit PWM Control and Dot-Correction

### Electrical Characteristics (V<sub>DD</sub>=3.3V, T<sub>a</sub>=25 °C)

| Characteristics                                       | Symbol                | Condition  | Min.  | Typ.                 | Max.  | Unit                |    |
|---|-----------------------|--|---|----------------------|-------|---------------------|----|
| Supply Voltage  | V <sub>DD</sub>       | -  | 3.0   | 3.3                  | 3.6   | V                   |    |
| Sustaining Voltage at OUT Ports                       | V <sub>DS</sub>       | $\overline{\text{OUT0}} \sim \overline{\text{OUT15}}$                  | -   | -                    | 17.0  | V                   |    |
| Output Current  | I <sub>OUT</sub>      | Refer to 'Test Circuit for Electrical Characteristics'                 | 2   | -                    | 45    | mA                  |    |
|   | I <sub>OH</sub>       | SDO  | -   | -                    | -1.0  | mA                  |    |
|   | I <sub>OL</sub>       | SDO  | -   | -                    | 1.0   | mA                  |    |
| Output Leakage Current                                | I <sub>OUT</sub>      | V <sub>DS</sub> =17.0V   | -   | -                    | 0.5μA |                     |    |
| Current Skew (Channel)                                | dI <sub>OUT</sub>     | I <sub>OUT</sub> =25.8mA<br>V <sub>DS</sub> =1.0V                      | R <sub>ext</sub> =560Ω-   | ±1.5                 |       | ±3.0                | %  |
|   | dI <sub>OUT</sub>     | I <sub>OUT</sub> =45mA<br>V <sub>DS</sub> =1.0V                        | R <sub>ext</sub> =310Ω-   | ±1.5                 |       | ±3.0                | %  |
| Current Skew (IC)                                     | dI <sub>OUT2</sub>    | I <sub>OUT</sub> =25.8mA<br>V <sub>DS</sub> =1.0V                      | R <sub>ext</sub> =560Ω-   | ±3.0                 |       | ±6.0                | %  |
|   | dI <sub>OUT2</sub>    | I <sub>OUT</sub> =45mA<br>V <sub>DS</sub> =1.0V                        | R <sub>ext</sub> =310Ω-   | ±3.0                 |       | ±6.0                | %  |
| Output Current vs. Output Voltage Regulation*         | %/dV <sub>DS</sub>    | V <sub>DS</sub> within 1.0V and 3.0V,<br>R <sub>ext</sub> =560Ω@25.8mA | -   | ±0.1                 | ±0.5  | % / V               |    |
| Output Current vs. Supply Voltage Regulation*         | %/dV <sub>DD</sub>    | V <sub>DD</sub> within 3.0V and 3.6V                                   | -   | ±0.5                 | ±1.5  | % / V               |    |
| Input Voltage of SDI, DCLK, LE, GCLK                  | "H" level             | V <sub>IH</sub>  | T <sub>a</sub> =-40~85°C  | 0.7xV <sub>DD</sub>  | -     | V <sub>DD</sub>     | V  |
|   | "L" level             | V <sub>IL</sub>  | T <sub>a</sub> =-40~85°C  | GND                  | -     | 0.3xV <sub>DD</sub> | V  |
| Output Voltage  | SDO                   | V <sub>OH</sub>  | I <sub>OH</sub> =-1.0mA   | V <sub>DD</sub> -0.4 | -     | -                   | V  |
|   |                       | V <sub>OL</sub>  | I <sub>OL</sub> =+1.0mA   | -                    | -     | 0.4                 | V  |
| LED Open Error Detection Threshold                    | V <sub>DS,TH</sub>    | -  | -   | 0.30                 | 0.35  | V                   |    |
| Pull-down Resistor of LE                              | R <sub>IN(down)</sub> | -  | 250   | 450                  | 800   | KΩ                  |    |
| Supply Current (DCLK=GCLK=0Hz)                        | "Off"                 | I <sub>DD(off) 1</sub>   | R <sub>ext</sub> =Open, $\overline{\text{OUT0}} \sim \overline{\text{OUT15}} = \text{Off}$  | -                    | 1.9   | 4.5                 | mA |
|   |                       | I <sub>DD(off) 2</sub>   | R <sub>ext</sub> =560Ω, $\overline{\text{OUT0}} \sim \overline{\text{OUT15}} = \text{Off}$  | -                    | 6.1   | 9.5                 |    |
|   |                       | I <sub>DD(off) 3</sub>   | R <sub>ext</sub> =310Ω, $\overline{\text{OUT0}} \sim \overline{\text{OUT15}} = \text{Off}$  | -                    | 8.3   | 11.5                |    |
|   | "On"                  | I <sub>DD(on) 1</sub>  | R <sub>ext</sub> =560Ω, $\overline{\text{OUT0}} \sim \overline{\text{OUT15}} = \text{On}$   | -                    | 6.1   | 11                  |    |
|   |                       | I <sub>DD(on) 2</sub>  | R <sub>ext</sub> =310Ω, $\overline{\text{OUT0}} \sim \overline{\text{OUT15}} = \text{On}$   | -                    | 9.4   | 13                  |    |
| Supply Current (DCLK=GCLK=30MHz, SDI=15Mhz switching) | "On"                  | I <sub>DD(on) 1</sub>  | R <sub>ext</sub> =560Ω, $\underline{\text{OUT0}} \sim \underline{\text{OUT15}} = \text{On}$ | -                    | 16.2  | -                   |    |
|   |                       | I <sub>DD(on) 2</sub>  | R <sub>ext</sub> =310Ω, $\text{OUT0} \sim \text{OUT15} = \text{On}$                         | -                    | 16.7  | -                   |    |
| Thermal Flag Temperature 1 **                         | T <sub>TF1</sub>      | Junction Temperature   | -   | 140                  | -     | °C                  |    |
| Thermal Flag Temperature 2 **                         | T <sub>TF2</sub>      | Junction Temperature   | -   | 160                  | -     | °C                  |    |

\*One channel on.

\*\*Thermal flag 1 is over-temperature alarm, and thermal flag 2 is thermal shutdown.

# With 16-Bit PWM Control and Dot-Correction

## Test Circuit for Electrical Characteristics

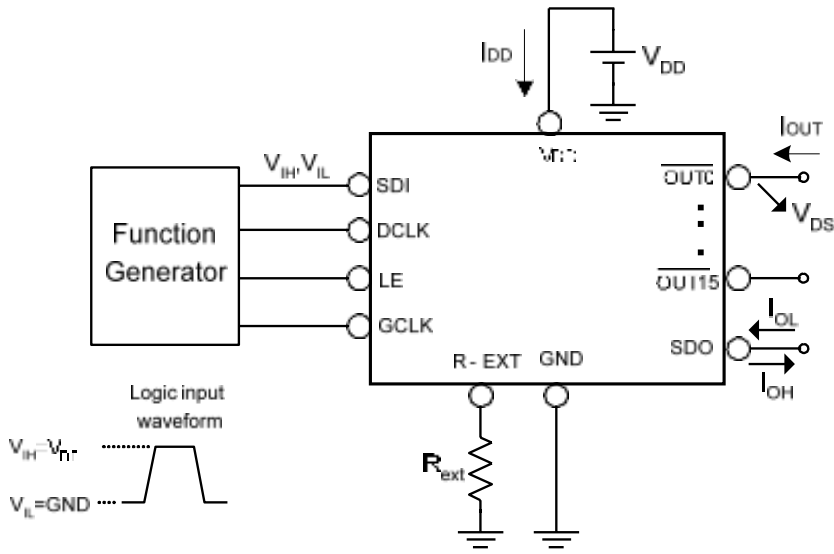



**With 16-Bit PWM Control and Dot-Correction**  
**Switching Characteristics ( $V_{DD}=5.0V$ ;  $T_a=25\text{ }^\circ\text{C}$ )**

| Characteristics                                     |                                     | Symbol      | Condition   | Min. | Typ. | Max. | Unit |
|---|-------------------------------------|-------------|---|------|------|------|------|
| Setup Time  | SDI – DCLK $\uparrow$               | $t_{SU0}$   | $V_{DD}=5.0V$<br>$V_{IH}=V_{DD}$<br>$V_{IL}=GND$<br>$R_{ext}=700\Omega$<br>$V_{DS}=1V$<br>$R_L=150\Omega$<br>$C_L=10pF$<br>$C_1=100nF$<br>$C_2=10\mu F$<br>$C_{SDO}=10pF$<br>$V_{LED}=4.0V$ | 1    | -    | -    | ns   |
|   | LE $\uparrow$ – DCLK $\uparrow$     | $t_{SU1}$   |   | 1    | -    | -    | ns   |
|   | LE $\downarrow$ – DCLK $\uparrow$   | $t_{SU2}$   |   | 5    | -    | -    | ns   |
| Hold Time   | DCLK $\uparrow$ – SDI               | $t_{H0}$    |   | 3    | -    | -    | ns   |
|   | DCLK $\uparrow$ – LE $\downarrow$   | $t_{H1}$    |   | 7    | -    | -    | ns   |
|   | DCLK $\downarrow$ – LE $\downarrow$ | $t_{H2}$    |   | 10   | -    | -    | ns   |
| Propagation Delay Time                              | DCLK – SDO                          | $t_{PD0}$   |   | -    | 25   | 33   | ns   |
|   | GCLK – $\overline{OUT4n}$ *         | $t_{PD1}$   |   | -    | 50   | -    | ns   |
|   | LE – SDO**                          | $t_{PD2}$   |   | -    | 30   | 40   | ns   |
| Staggered Delay of Output                           | $\overline{OUT4n}$ 1 *              | $t_{DL1}$   |   | -    | 5    | -    | ns   |
|   | $\overline{OUT4n}$ 2 *              | $t_{DL2}$   |   | -    | 10   | -    | ns   |
|   | $\overline{OUT4n}$ 3 *              | $t_{DL3}$   |   | -    | 15   | -    | ns   |
| Pulse Width   | LE                                  | $t_{w(L)}$  |   | 5    | -    | -    | ns   |
| In-message Error Detection Duration (Count by GCLK) |                                     | $t_{EDD}$   |   | -    | -    | 10   | GCLK |
| Compulsory Error Detection Operation Time***        |                                     | $t_{ERR-C}$ | -   | -    | 700  | ns   |      |
| Data Clock Frequency                                |                                     | $F_{DCLK}$  | -   | -    | 30   | MHz  |      |
| Gray Scale Clock Frequency****                      |                                     | $F_{GCLK}$  | -   | -    | 33   | MHz  |      |
| Switching Speed of Output Channels                  | High-Speed                          | Rise Time   | $t_{OR}$  | -    | 11   | -    | ns   |
|   |                                     | Fall Time   | $t_{OF}$  | -    | 20   | -    | ns   |
|   | Low-Speed                           | Rise Time   | $t_{OR}$  | -    | 19   | -    | ns   |
|   |                                     | Fall Time   | $t_{OF}$  | -    | 25   | -    | ns   |

\* Refer to the Timing Waveform in P.12, where n=0, 1, 2, 3.

\*\*In timing of 'Read Configuration' and 'Read Error Status Code', the next DCLK rising edge should be  $t_{PD2}$  after the falling edge of LE.

\*\*\*Users have to leave more time than the maximum error detection time for the error detection.

\*\*\*\*With uniform output current.

## With 16-Bit PWM Control and Dot-Correction

### Switching Characteristics ( $V_{DD}=3.3V$ ; $T_a=25^\circ C$ )

| Characteristics                                     |                                     | Symbol         | Condition   | Min. | Typ. | Max.   | Unit |
|---|-------------------------------------|----------------|---|------|------|--------|------|
| Setup Time  | SDI–DCLK $\uparrow$                 | $t_{SU0}$      | $V_{DD}=3.3V$<br>$V_{IH}=V_{DD}$<br>$V_{IL}=GND$<br>$R_{ext}=700\Omega$<br>$V_{DS}=1V$<br>$R_L=150\Omega$<br>$C_L=10pF$<br>$C_1=100nF$<br>$C_2=10\mu F$<br>$C_{SDO}=10pF$<br>$V_{LED}=4.0V$ | 1    | -    | -      | ns   |
|   | LE $\uparrow$ – DCLK $\uparrow$     | $t_{SU1}$      |   | 1    | -    | -      | ns   |
|   | LE $\downarrow$ – DCLK $\uparrow$   | $t_{SU2}$      |   | 5    | -    | -      | ns   |
| Hold Time   | DCLK $\uparrow$ – SDI               | $t_{H0}$       |   | 3    | -    | -      | ns   |
|   | DCLK $\uparrow$ – LE $\downarrow$   | $t_{H1}$       |   | 7    | -    | -      | ns   |
|   | DCLK $\downarrow$ – LE $\downarrow$ | $t_{H2}$       |   | 10   | -    | -      | ns   |
| Propagation Delay Time                              | DCLK– SDO                           | $t_{PD0}$      |   | -    | 30   | 40     | ns   |
|   | GCLK– $\overline{OUT4n}$ *          | $t_{PD1}$      |   | -    | 60   | -      | ns   |
|   | LE– SDO                             | $t_{PD2}^{**}$ |   | -    | 40   | 50     | ns   |
| Staggered Delay of Output                           | $\overline{OUT4n}$ 1 *              | $t_{DL1}$      |   | -    | 5    | -      | ns   |
|   | $\overline{OUT4n}$ 2 *              | $t_{DL2}$      |   | -    | 10   | -      | ns   |
|   | $\overline{OUT4n}$ 3 *              | $t_{DL3}$      |   | -    | 15   | -      | ns   |
| Pulse Width   | LE                                  | $t_{w(L)}$     |   | 5    | -    | -      | ns   |
| In-message Error Detection Duration (Count by GCLK) |                                     | $t_{EDD}$      |   | -    | 10   | GCLK   |      |
| Compulsory Error Detection Operation Time***        |                                     | $t_{ERR-C}$    |   | -    | -    | 700 ns |      |
| Data Clock Frequency                                |                                     | $F_{DCLK}$     |   | -    | -    | 25 MHz |      |
| Gray Scale Clock Frequency****                      |                                     | $F_{GCLK}$     |   | -    | -    | 20 MHz |      |
| Switching Speed of Output Channels                  | High-Speed                          | Rise Time      | $t_{OR}$  | -    | 17   | -      | ns   |
|   |                                     | Fall Time      | $t_{OF}$  | -    | 25   | -      | ns   |
|   | Low-Speed                           | Rise Time      | $t_{OR}$  | -    | 28   | -      | ns   |
|   |                                     | Fall Time      | $t_{OF}$  | -    | 48   | -      | ns   |

\* Refer to the Timing Waveform in P.12, where n=0, 1, 2, 3.

\*\*In timing of 'Read Configuration' and 'Read Error Status Code', the next DCLK rising edge should be  $t_{PD2}$  after the falling edge of LE.

\*\*\*Users have to leave more time than the maximum error detection time for the error detection.

\*\*\*\*With uniform output current.

# With 16-Bit PWM Control and Dot-Correction

## Test Circuit for Switching Characteristics

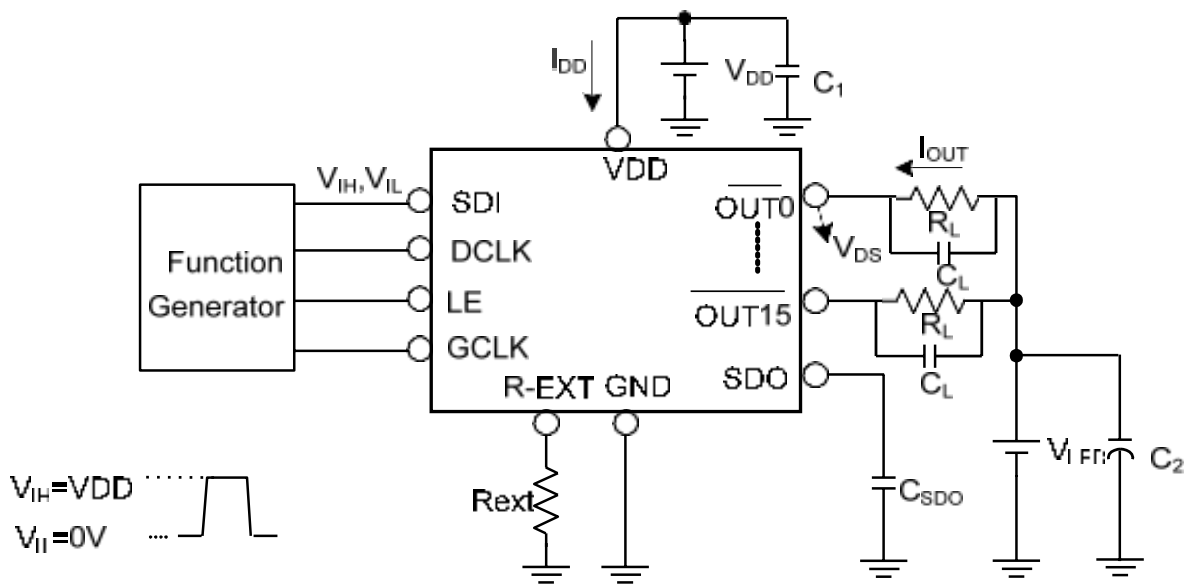

# With 16-Bit PWM Control and Dot-Correction

## Timing Waveform

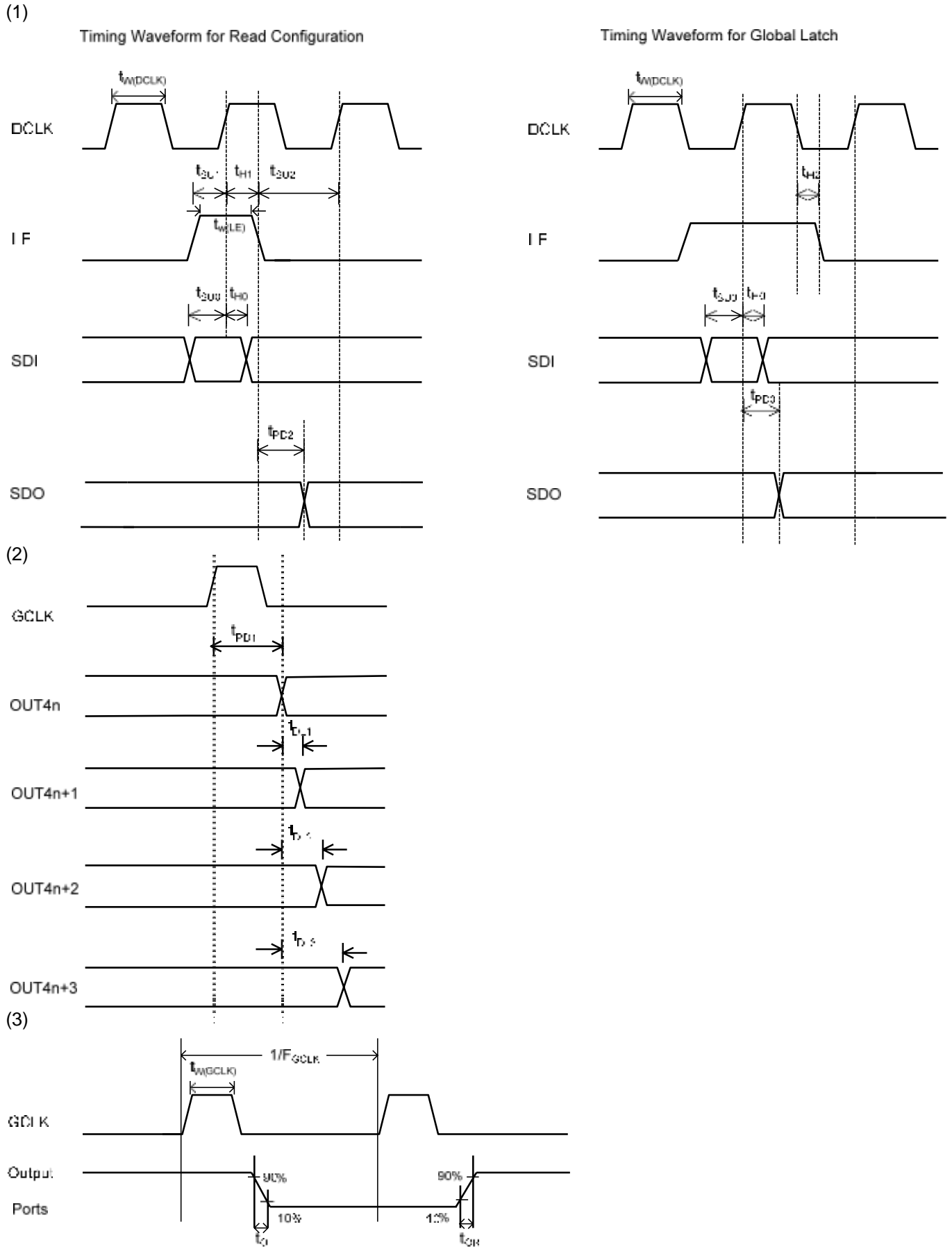

## With 16-Bit PWM Control and Dot-Correction

### Principle of Operation

Users should set the operation modes in the configuration register through the 'write configuration' command before sending gray scale data. The control command and configuration register are summarized in the following two tables.

### Control Command

| Command Name                                  | Signals Combination |  | Description  |
|---|---------------------|--|--|
|   | LE                  | Number of DCLK Rising Edge When LE is Asserted | The Action After a Falling Edge of LE  |
| Latch data or stop compulsory error detection | High                | 0  | Latch the serial data to the register for gray scale or dot correction or configuration register or stop compulsory error detection. |
| Dot correction                                | High                | 1  | Enter the dot correction mode; the shift register is set to be 128 bits  |
| Enable output                                 | High                | 3  | Enable output channels and activate the PWM counter  |
| Compulsory error detection                    | High                | 4  | Start compulsory error detection   |
| Write configuration                           | High                | 5  | Write 16-bit configuration register  |
| Read configuration                            | High                | 6  | Read the configuration register value  |
| Disable output                                | High                | 7  | Disable output channels and reset the PWM counter  |
| 12-bit gray scale setting                     | High                | 192(12x16)                                     | Set the 12-bit gray scale mode   |
| 16-bit gray scale setting                     | High                | 256(16x16)                                     | Set the 16-bit gray scale mode   |

Note: Please do **NOT** use the number of DCLK which are not specified in the table. Otherwise, it might cause malfunction on the LED drivers.

## With 16-Bit PWM Control and Dot-Correction

### Definition of Configuration Register

|                    |   |   |   |   |   |    |   |   |         |   |   |   |   |     |   |
|--------------------|---|---|---|---|---|----|---|---|---------|---|---|---|---|-----|---|
| MSB                |   |   |   |   |   |    |   |   |         |   |   |   |   | LSB |   |
| F                  | E | D | C | B | A | 9  | 8 | 7 | 6       | 5 | 4 | 3 | 2 | 1   | 0 |
| e.g. Default Value |   |   |   |   |   |    |   |   |         |   |   |   |   |     |   |
| F                  | E | D | C | B | A | 9  | 8 | 7 | 6       | 5 | 4 | 3 | 2 | 1   | 0 |
| 1                  | 1 | 1 | 0 | 1 | 1 | 00 |   | 0 | 1111111 |   |   |   |   |     |   |

| Bit | Attribute  | Definition                                   | Value             | Function   |
|-----|------------|--|-------------------|--|
| F   | Read/Write | PWM gray scale mode                          | 0                 | 12 bits  |
|     |            |  | 1 (Default)       | 16 bits  |
| E   | Read/Write | PWM algorithm                                | 0                 | Conventional PWM   |
|     |            |  | 1 (Default)       | S-PWM, divide the duty into 64 parts   |
| D   | Read/Write | PWM data synchronization                     | 0                 | Manual synchronization   |
|     |            |  | 1 (Default)       | Auto synchronization   |
| C   | Read/Write | PWM counting mode                            | 0 (Default)       | Continuous counting mode   |
|     |            |  | 1                 | One-shot counting mode   |
| B   | Read/Write | Thermal shutdown                             | 0                 | Disable thermal shutdown   |
|     |            |  | 1 (Default)       | Enable thermal shutdown  |
| A   | Read/Write | Error detection                              | 0                 | Disable both in-message and compulsory error detections  |
|     |            |  | 1 (Default)       | Enable both in-message and compulsory error detections   |
| 9~8 | Read/Write | Threshold voltage of short-circuit detection | 00 (Default)      | 2 b00: Disable short-circuit detection   |
|     |            |  | 01                | 2 b01: $0.4 \times V_{DD} \pm 0.1(V)$  |
|     |            |  | 10                | 2 b10: $0.5 \times V_{DD} \pm 0.1(V)$  |
|     |            |  | 11                | 2 b11: $0.73 \times V_{DD} \pm 0.1(V)$   |
| 7   | Read/Write | Switching speed of output channels           | 0 (Default)       | Low switching speed  |
|     |            |  | 1                 | High switching speed   |
| 6~0 | Read/Write | Output current gain adjustment               | 1111111 (Default) | Output current; $I = I_o \times \text{Current Gain}[6:0]/127$ ;<br>$I_o = (V_{R-EXT}/R_{ext}) \times 23$ |

### Shift Register

The effective length of the shift register in MBI5040 is auto-adjusted among 256 / 192 / 128 / 16 bits according to different modes of input data.

### Write Configuration Register

MBI5040 can write the configuration register when receiving one LE pulse containing 5 DCLKs, and then send 16-bit configuration setting to each LED driver. The following waveform shows the input signal waveform when cascading N pieces of MBI5040:

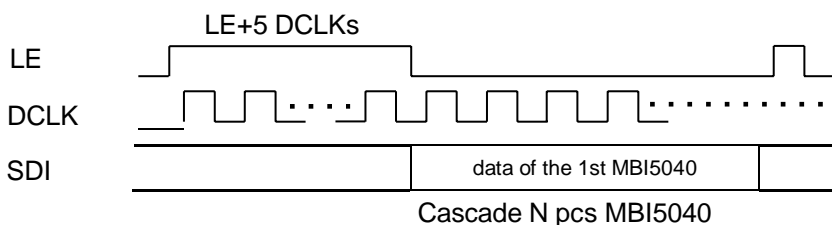

# With 16-Bit PWM Control and Dot-Correction

## Read Configuration Register

MBI5040 can read the configuration register when receiving one LE pulse containing 5 DCLKs in order to set the shift register length to 16 bits, and then send one LE pulse containing 6 DCLKs to read the configuration setting. After the command, 16-bit configuration of each MBI5040 will be shifted out sequentially from the Nth MBI5040 to the 1st MBI5040. The following waveform shows the output signal waveform when cascading N pieces of MBI5040:

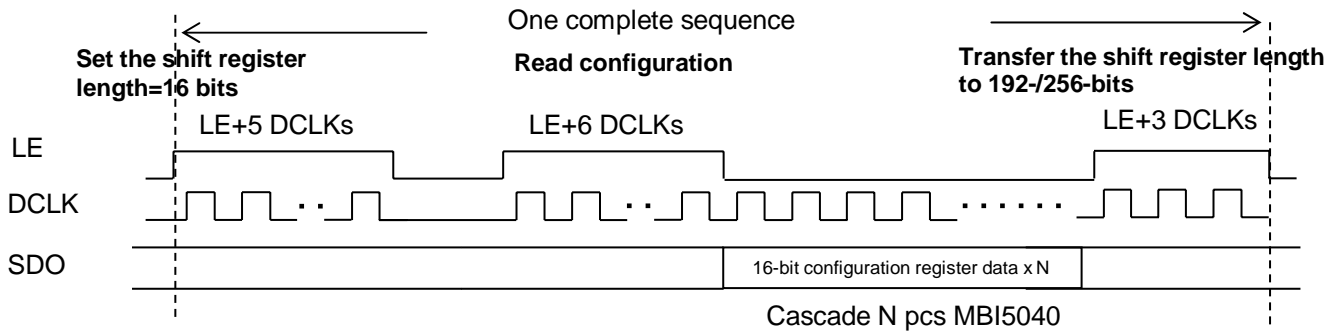

## Input the Dot Correction Data

MBI5040 can input the dot correction data when receiving one LE pulse containing one DCLK, and then send 128-bit dot correction data to each LED driver. The following waveform shows the input signal waveform when cascading N pieces of MBI5040:

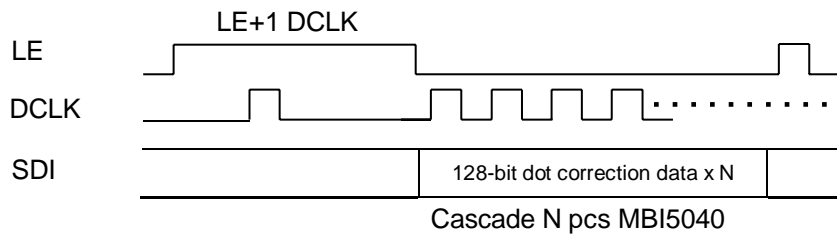

## Enable and Disable Output

MBI5040 can disable output channels when receiving one LE pulse containing 7 DCLKs. The output channels will be enabled again when receiving one LE pulse containing 3 DCLKs. This 'enable' command can also reactivate the IC from thermal shutdown when the junction temperature decreases.

# With 16-Bit PWM Control and Dot-Correction

## Set the PWM Gray Scale Mode

MBI5040 provides a selectable 16-bit or 12-bit gray scale mode by setting bit 'F' of the configuration register. For 16-bit gray scale mode, the bit 'F' is set to '1' (default), and for 12-bit gray scale mode, the bit 'F' is set to '0'.

Users need to set the gray scale mode before sending the data, and then send the data from Nth MBI5040 to the 1st MBI5040. MBI5040 will enter 16-bit or 12-bit gray scale mode when receiving one LE pulse containing 256 DCLKs or 192 DCLKs respectively. To latch the data, the command of one LE pulse containing 0 DCLK should be sent after the gray scale mode. Then MBI5040 will enable the output when receiving one LE pulse containing 3 DCLKs. The following waveform shows the input signal waveform when cascading N pieces of MBI5040:

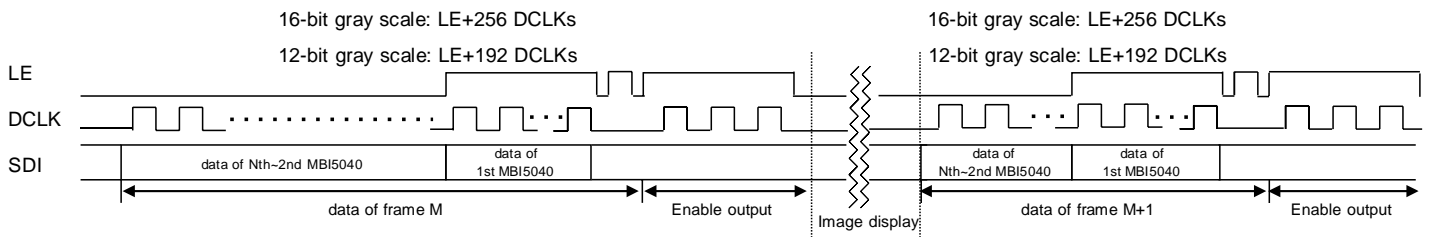

## Gray Scale Data Format

The data input sequence of both 16-bit and 12-bit gray scale data are the same, and the following waveform illustrates the sequence:

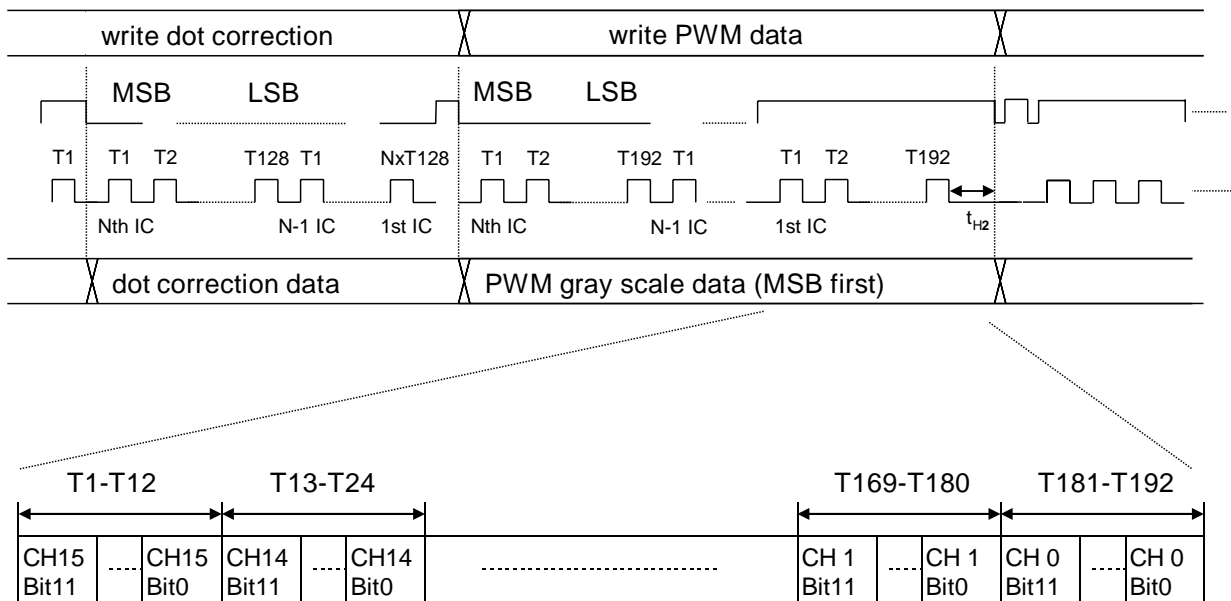

$t_{H2}$ : In the end of gray scale mode,  $DCLK \downarrow - LE \downarrow$  should be no less than 10ns.



# With 16-Bit PWM Control and Dot-Correction

## Set the PWM Counting Mode

### PWM Algorithm

MBI5040 defines the different counting algorithms that support scrambled PWM technology, S-PWM. With S-PWM, the total PWM cycles can be broken down into MSB (Most Significant Bits) and LSB (Least Significant Bits) of gray scale cycles, and the MSB information can be dithered across 63 refresh cycles.

MBI5040 is flexible for either the conventional PWM algorithm or S-PWM algorithm by setting bit 'E' of the configuration register. For S-PWM algorithm, the bit 'E' is set to '1' (default), and for conventional PWM algorithm, the bit 'E' is set to '0':

### Conventional PWM

Bit E= '0':

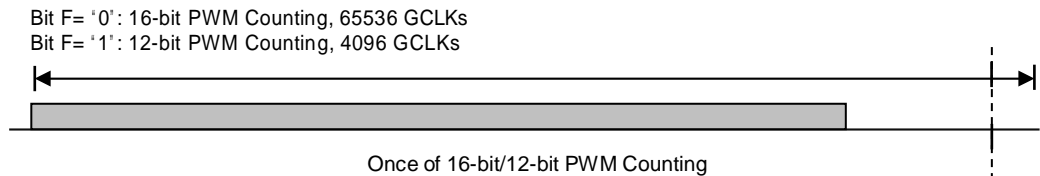

### S-PWM

Bit E= '1':

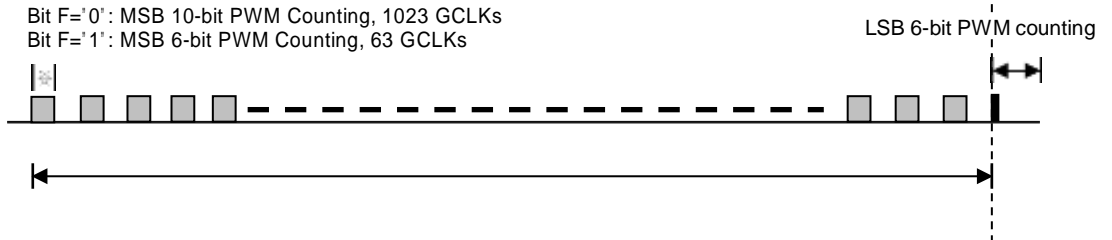

█ : Output ports are turned 'on'.

## Synchronization of PWM Cycle

MBI5040 is also flexible for either manual synchronization or auto synchronization by setting bit 'D' of the configuration register.

For auto synchronization, the bit 'D' is set to '1' (default). MBI5040 will automatically process the synchronization of previous data and next data for PWM counting. The next image data will be updated to output buffers and start PWM counting when the previous data finishes one internal PWM cycle. This prevents the lost count of image data resolution and guarantees the data accuracy.

For manual synchronization, the bit 'D' is set to '0'. Once the next input data is correctly recognized, MBI5040 will stop the present PWM cycle and restart a new PWM cycle to show the new data immediately.

## With 16-Bit PWM Control and Dot-Correction

### PWM Counting Mode

Users can set either continuous counting mode or one-shot counting mode by setting bit 'C' of the configuration register.

For the continuous counting mode, the bit 'C' is set to '0' (default). In the continuous counting mode, MBI5040 will continuously repeat the PWM cycles and turn on the output channels according to the image data until the next image data is correctly recognized.

For the one-shot counting mode, the bit 'C' is set to '1'. In the one-shot counting mode, MBI5040 will run the PWM cycle for each image data one time, and then stop the output channels until the next image data is correctly recognized.

### Error Detection Principle

MBI5040 provides two error detection functions: in-message error detection and compulsory error detection. Users can read the open-/short-circuit error reports, and thermal flag from SDO. For all the detection functions, '0' indicates error or abnormal state and '1' indicates normal state.

### In-message Error Detection

Users can set the in-message error detection by bit 'A' of configuration register. To enable the in-message error detection, the bit 'A' is set to '1' (default). To disable the in-message error detection, the bit 'A' is set to '0'.

The open-/short-circuit error will be reported only when output channels are turned on in 10 GCLKs, and the error reports will be put into the shift register after the gray scale data is latched.

Since the PWM output duty cycle of MBI5040 is the product of gray scale data and dot correction data. If the S-PWM algorithm is selected, the open-/short-circuit in-message error detection will be performed while the product of gray scale data and dot correction data is from 640 to 65,535 in the 16-bit gray scale mode or from 640 to 4,095 in the 12-bit gray scale mode. If the conventional PWM algorithm is selected, the open-/short-circuit error will be reported when the product of gray scale data and dot correction data is larger than 10.

MBI5040 will judge if the turn-on time is enough or not to deliver the error report. If the turned-on time is too short, MBI5040 will report normal state coded as '1'.

Error data (N)=error data(N-1) presents detection result.

It will be reset to 1 until the error data is read out.

# With 16-Bit PWM Control and Dot-Correction

Please see the example of the following diagram of 12-bit gray scale mode for the control sequence and data output format of all error reports.

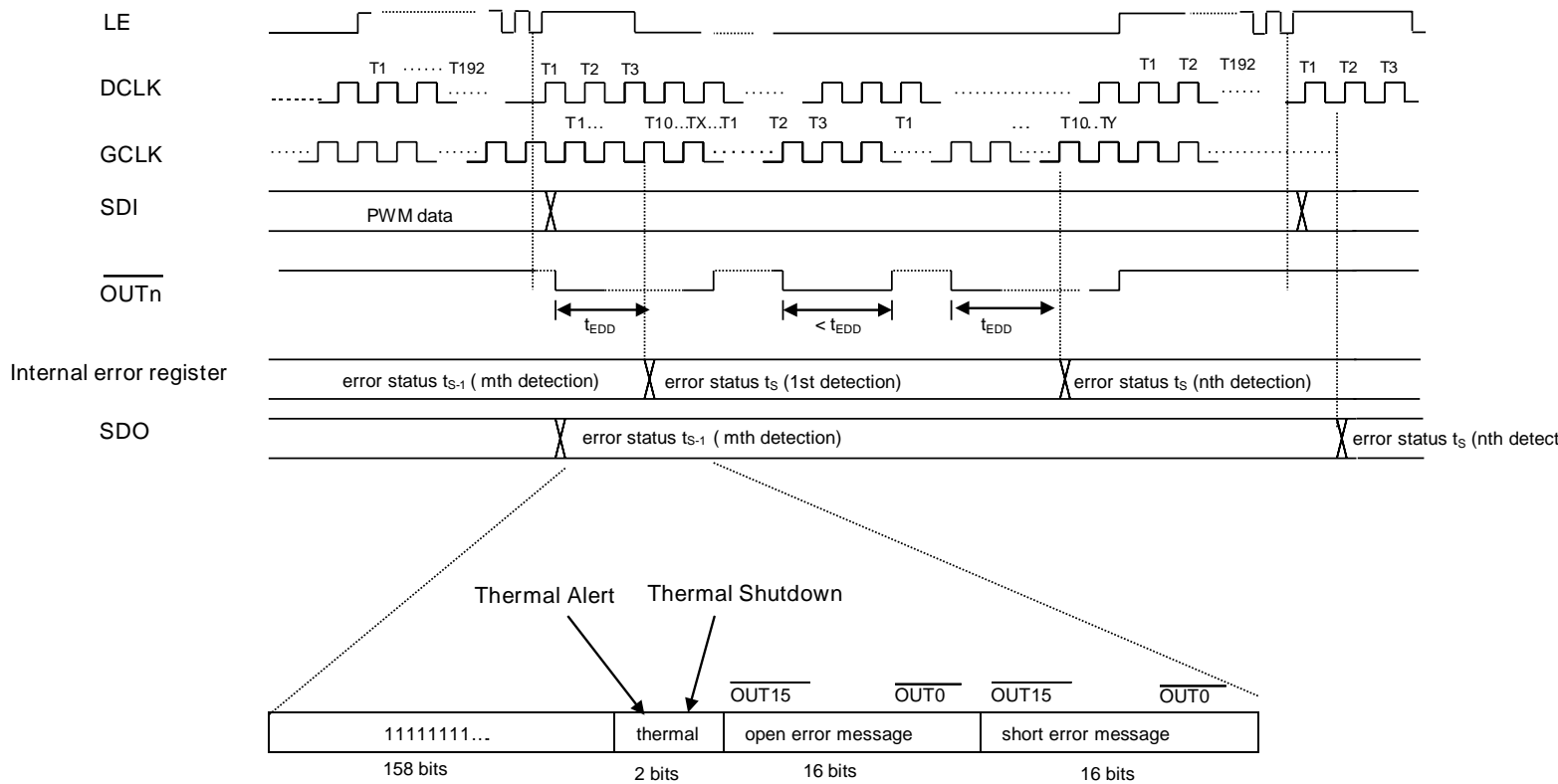

Note:

$t_S$ : the Sth frame

$t_{S-1}$ : the (S-1)th frame

$t_{EDD}=10$  GCLKs

# With 16-Bit PWM Control and Dot-Correction

## Compulsory Error Detection

MBI5040 can also perform the compulsory error detection when receiving one LE pulse containing 4 DCLKs and stop the compulsory error detection when receiving one LE pulse containing 0 DCLK. The output channels will be forced to turned on within 700ns (between the LE falling edges) to perform the compulsory error detection. The error report will be pushed out after compulsory error detection operation time (700ns). MBI5040 will shift out both open and short error reports from SDO simultaneously. The following is an illustration of the timing sequence of compulsory error detection of 12-bit gray scale mode.

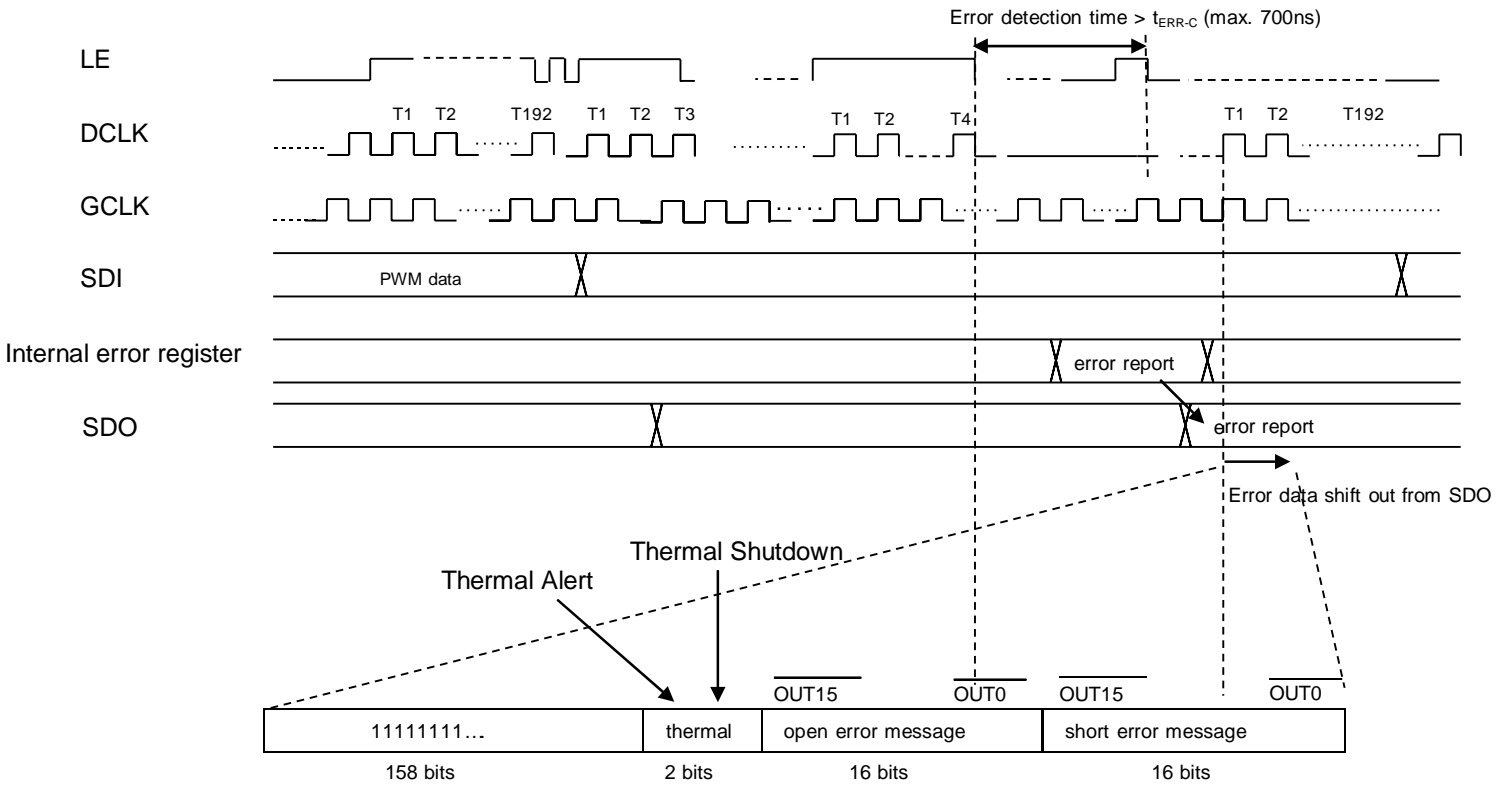

## With 16-Bit PWM Control and Dot-Correction

### Setting the Threshold Voltage for Compulsory Short-Circuit Detection

Users can set the threshold voltage ( $V_{SD,TH}$ ) for compulsory short-circuit detection by bit [9:8] of configuration register as summarized below:

2 b00: Disable the short-circuit detection (default)

2 b01:  $0.4 \times V_{DD} \pm 0.1(V)$

2 b10:  $0.5 \times V_{DD} \pm 0.1(V)$

2 b11:  $0.73 \times V_{DD} \pm 0.1(V)$

MBI5040 provides settable  $V_{SD,TH}$  for different LED configuration. If the detected voltage is larger than  $V_{SD,TH}$ , the MBI5040 identifies the LED as short-circuit. For example, if each output channel of MBI5040 drives one red LED, the  $V_{SD,TH}$  should be set smaller. If each output channel of MBI5040 drives several white LEDs, the  $V_{SD,TH}$  should be set larger. The system should consider the accumulated  $V_F$  of the LEDs to set a suitable  $V_{SD,TH}$ .

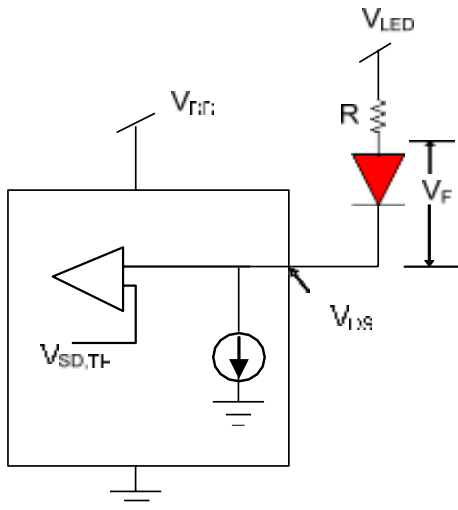

### Thermal Protection

Users can set the thermal protection by bit 'B' of configuration register. To enable the thermal shutdown function, the bit 'B' is set to '1' (default). To disable the thermal shutdown function, the bit 'B' is set to '0'.

MBI5040 provides two thermal flags:

Thermal flag 1 is over-temperature alarm, and thermal flag 2 is thermal shutdown. When the IC junction temperature is over  $140^{\circ}\text{C}$ , thermal flag 1 will report '0'. When the IC junction temperature is under  $120^{\circ}\text{C}$ , thermal flag 1 will recover to '1'.

When the IC junction temperature is over  $160^{\circ}\text{C}$ , the thermal flag 2 will become '0' and MBI5040 will turn off the output current of all channels automatically. MBI5040 will turn on the output channels when receiving one LE pulse containing 3 DCLKs.

## With 16-Bit PWM Control and Dot-Correction

### Adjust the Switching Speed of the Output Channels

Users can select the switching speed of output channels by bit '7' of configuration register. For low switching speed, the bit '7' is set to '0' (default). For high switching speed, the bit '7' is set to '1'.

Low switching speed helps to reduce the EMI and overshoot of the output channels. On the other hand, high switching speed is suitable for high GCLK frequency and high refresh rate applications.

### Adjust the Output Current Gain

Users can adjust output current gain by bit [6:0] of configuration register. The default current gain value is 7b 1111111.

The output current;  $I = I_0 \times \text{Current Gain [6:0]} / 127$ , where  $I_0 = (V_{R-EXT} / R_{ext}) \times 23$

The current gain value is proportional to the output current. In other words, current gain value versus output current is linear. This function helps users to tune the output current by software in stead of by hardware for daily operation.

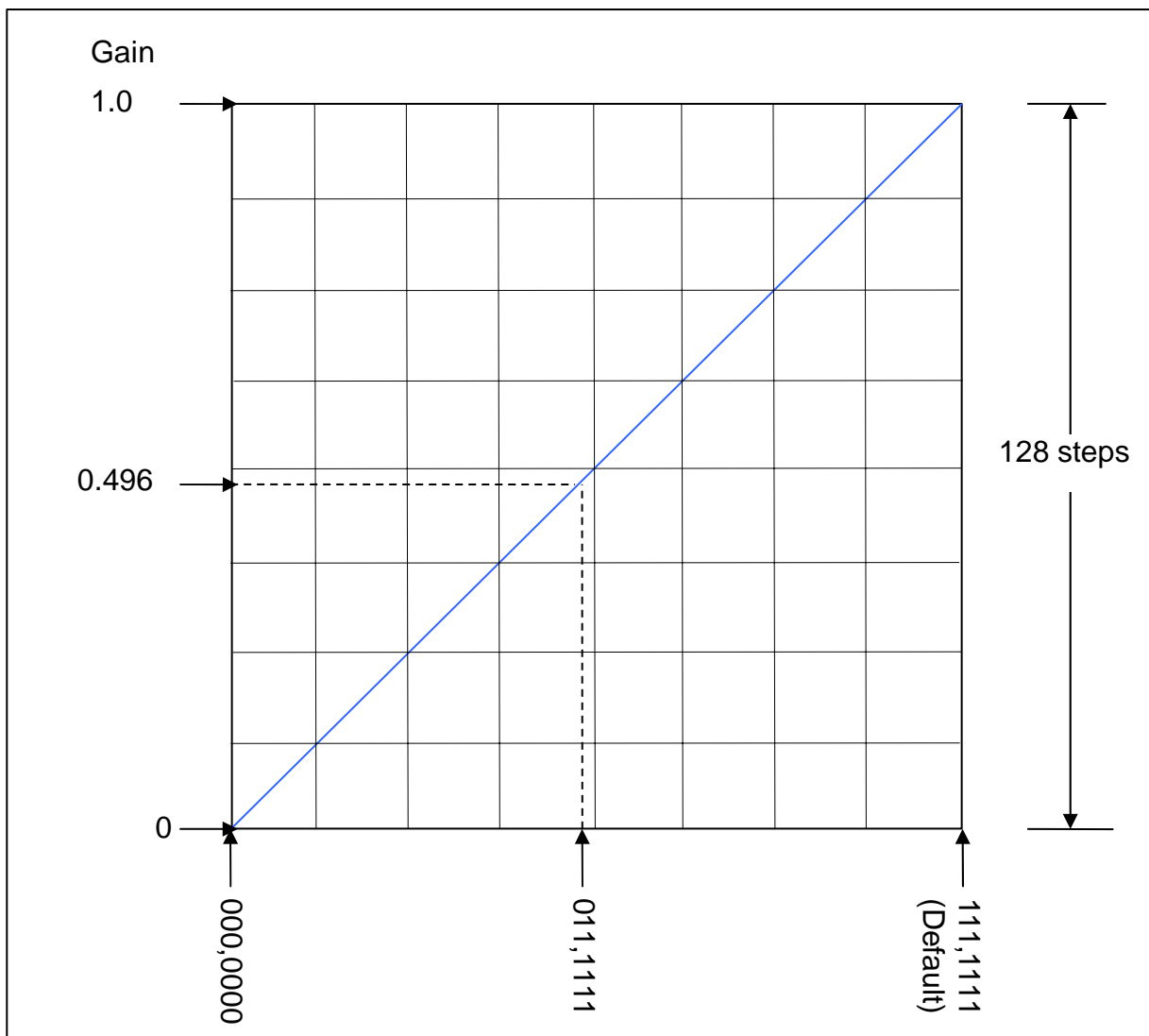

## With 16-Bit PWM Control and Dot-Correction

### Setting Output Current

The output current ( $I_{OUT}$ ) is set by an external resistor,  $R_{ext}$ . The default relationship between  $I_{OUT}$  and  $R_{ext}$  is shown in the following figure.

Also, the output current can be calculated from the equation:

$$V_{R-EXT}=0.61; I_{OUT}=(V_{R-EXT}/R_{ext})\times 23\times G/127$$

Whereas  $R_{ext}$  is the resistance of the external resistor connected to R-EXT terminal and  $V_{R-EXT}$  is its voltage. G is the digital current gain, which is set by the bit[6:0] of the configuration register. The default value of G is 127. For your information, the output current is about 25mA when  $R_{ext}=560\Omega$  and 45mA when  $R_{ext}=310\Omega$  if G is set to default value 127. The formula and setting for G are described in further section.

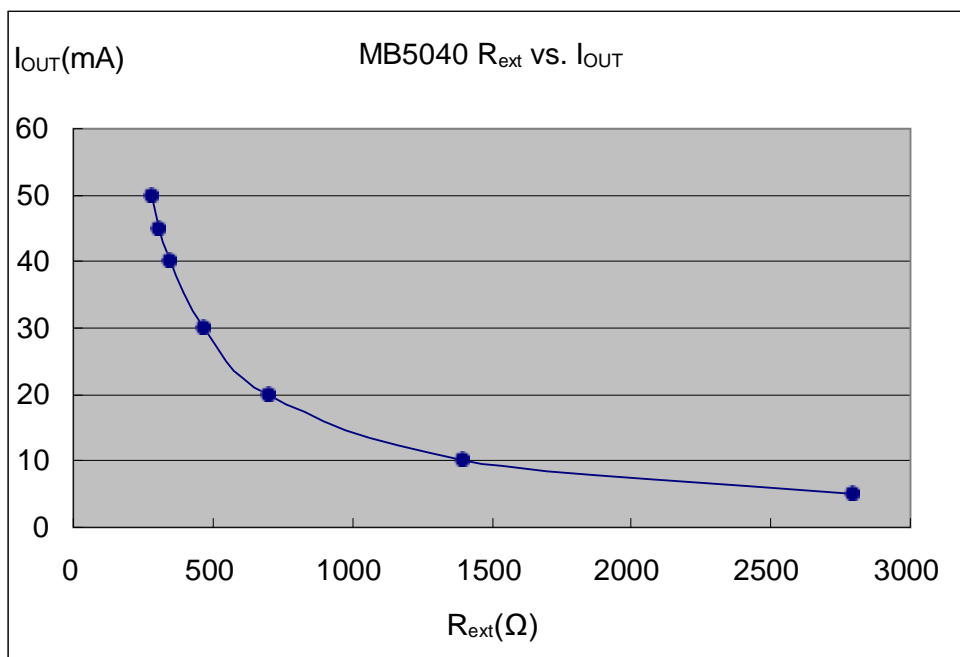

# With 16-Bit PWM Control and Dot-Correction

## Constant Current

In LED display application, MBI5040 provides nearly no variation in current from channel to channel and from IC to IC. This can be achieved by:

- 1) The typical current variation between channels is less than 1.5%, and that between ICs is less than  $\pm 3\%$ .
- 2) In addition, the current characteristic of output stage is flat and users can refer to the figure as shown below. The output current can be kept constant regardless of the variations of LED forward voltages ( $V_F$ ). This guarantees LED to be performed on the same brightness as user's specification.

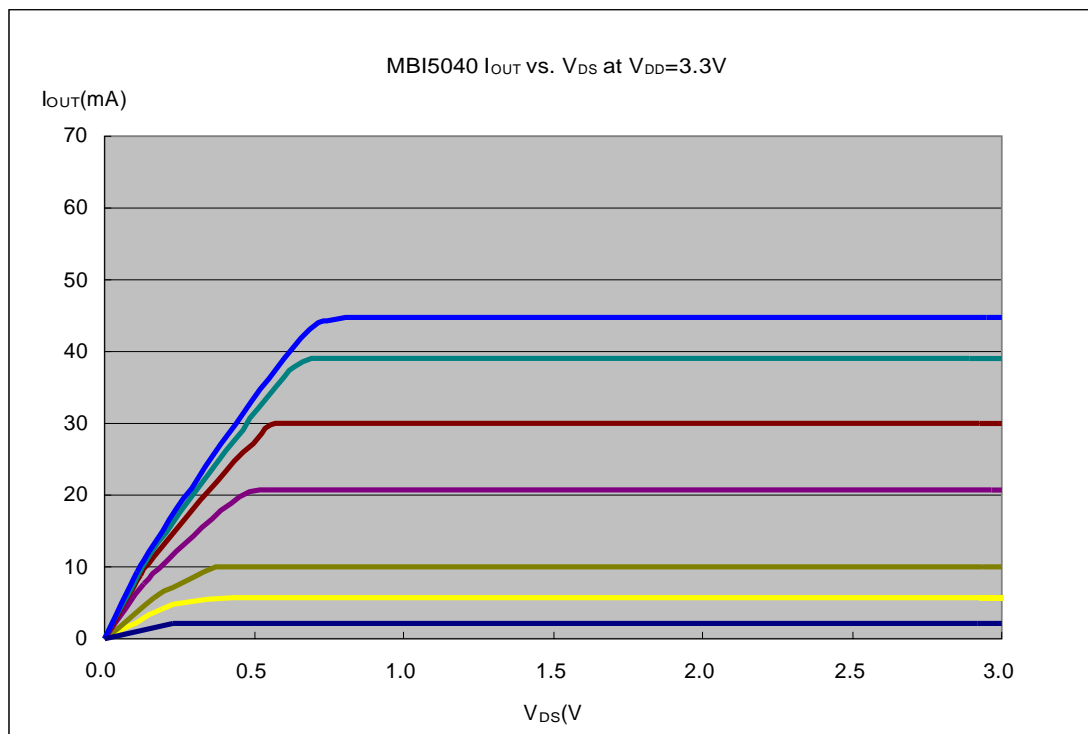
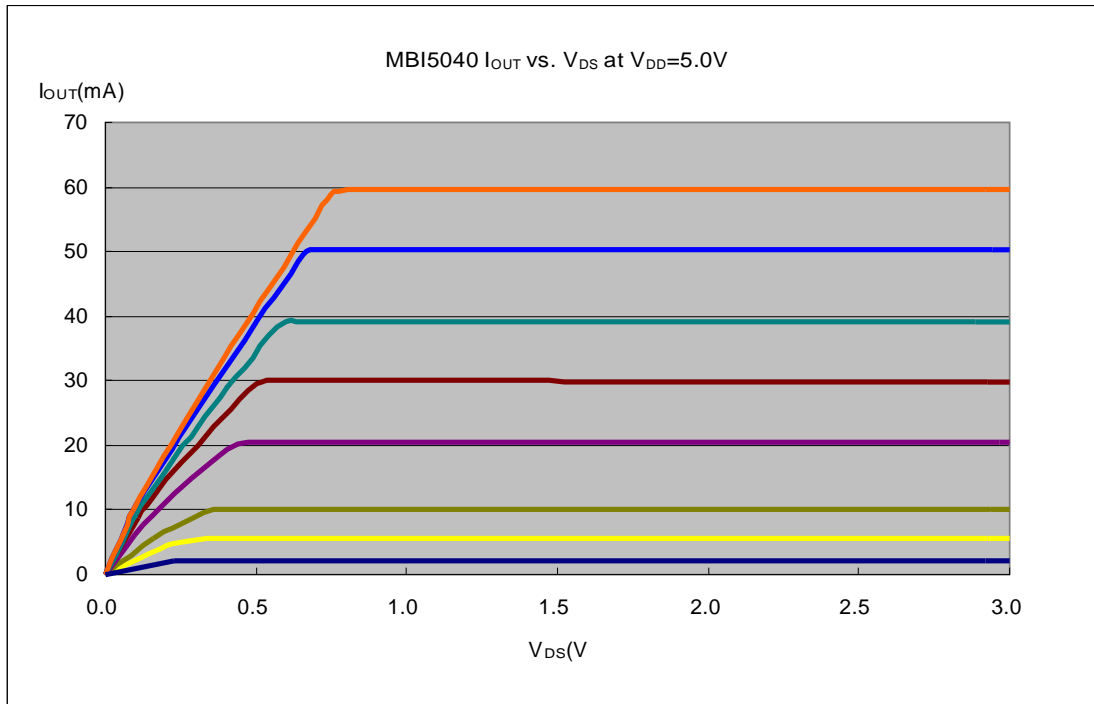



## With 16-Bit PWM Control and Dot-Correction

### Staggered Delay of Output

MBI5040 has a built-in staggered circuit to perform delay mechanism. Among output ports exist a graduated 5ns delay time among  $\overline{OUT4n}$ ,  $\overline{OUT4n-1}$ ,  $\overline{OUT4n-2}$ , and  $\overline{OUT4n-3}$ , by which the output ports will be divided to four groups at a different time so that the instant current from the power line will be lowered.

### Package Power Dissipation (PD)

The maximum allowable package power dissipation is determined as  $P_D(max) = (T_j - T_a) / R_{th(j-a)}$ . When 16 output channels are turned on simultaneously, the actual package power dissipation is

$P_D(act) = (I_{DD} \times V_{DD}) + (I_{OUT} \times Duty \times V_{DS} \times 16)$ . Therefore, to keep  $P_D(act) \leq P_D(max)$ , the allowable maximum output current as a function of duty cycle is:

$$I_{OUT} = \{ [(T_j - T_a) / R_{th(j-a)}] - (I_{DD} \times V_{DD}) \} / V_{DS} / Duty / 16, \text{ where } T_j = 150^\circ\text{C}.$$

The maximum power dissipation,  $P_D(max) = (T_j - T_a) / R_{th(j-a)}$ , decreases as the ambient temperature increases.

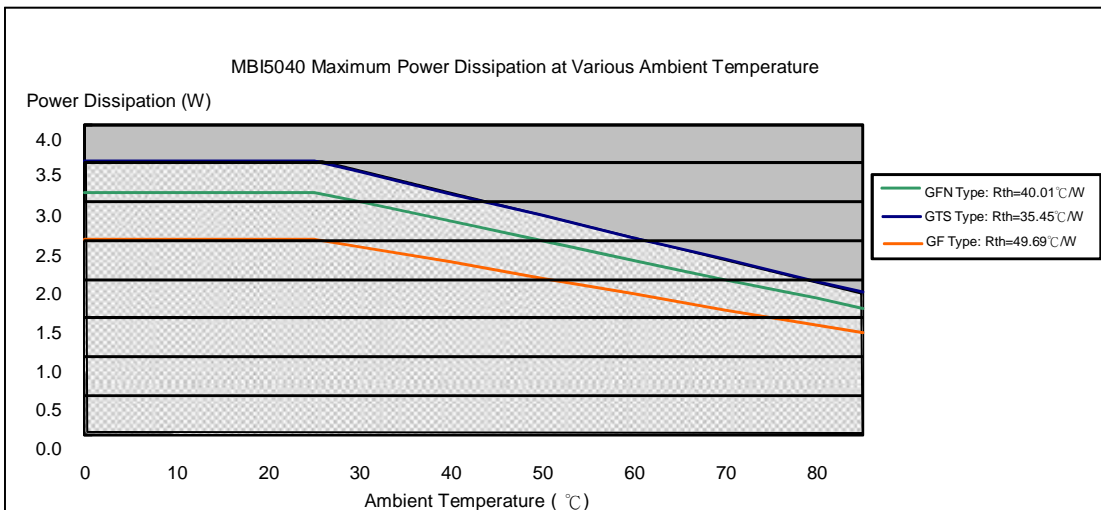

### Usage of Thermal Pad

The PCB area ( $L_2 \times W_2$ ) is 4 times of the IC's area ( $L_1 \times W_1$ ). The thickness of the PCB is 1.6mm, copper foil 1 Oz. The thermal pad on the IC's bottom has to be mounted on the copper foil.

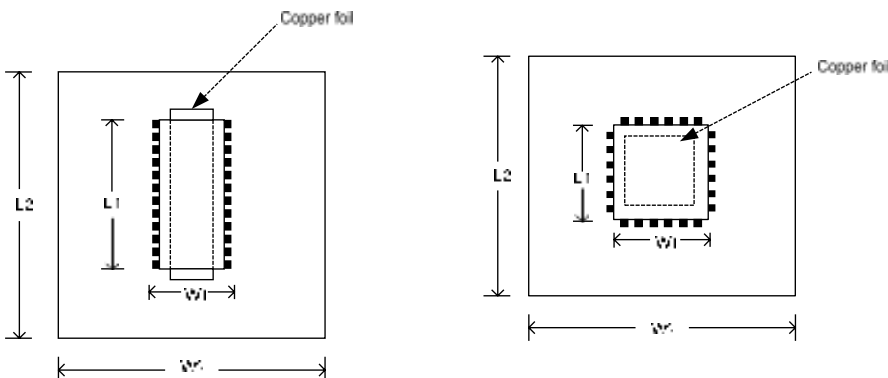

## With 16-Bit PWM Control and Dot-Correction

### LED Supply Voltage ( $V_{LED}$ )

MBI5040 are designed to operate with  $V_{DS}$  ranging from 0.4V to 1.0V (depending on  $I_{OUT}=2\sim 60mA$ ) considering the package power dissipating limits.  $V_{DS}$  may be higher enough to make  $P_{D (act)} > P_{D (max)}$  when  $V_{LED}=5V$  and  $V_{DS}=V_{LED}-V_F$ , in which  $V_{LED}$  is the load supply voltage. In this case, it is recommended to use the lowest possible supply voltage or to set an external voltage reducer,  $V_{DROP}$ .

A voltage reducer lets  $V_{DS}=(V_{LED}-V_F)-V_{DROP}$ .

Resistors or Zener diode can be used in the applications as shown in the following figures.

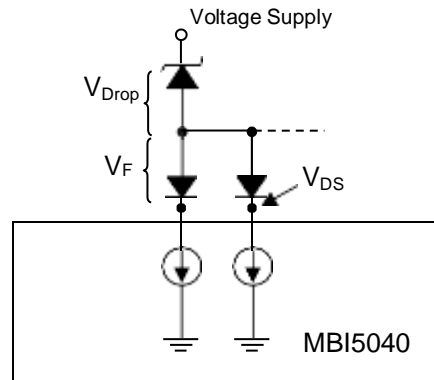
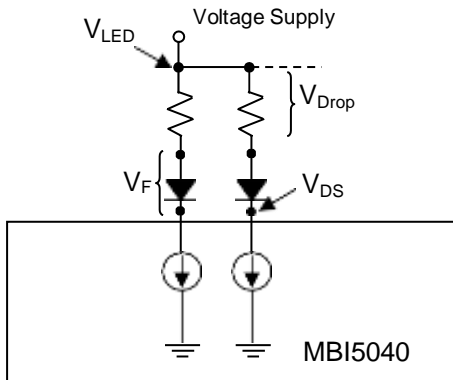

### Switching Noise Reduction

LED drivers are frequently used in switch-mode applications which always behave with switching noise due to the parasitic inductance on PCB. To eliminate switching noise, refer to 'Application Note for 8-bit and 16-bit LED Drivers-Overshoot'.

## With 16-Bit PWM Control and Dot-Correction

### Soldering Process of "Pb-free & Green" Package Plating\*

Macroblock has defined "Pb-Free" to mean semiconductor products that are compatible with the current RoHS requirements and selected 100% pure tin (Sn) to provide forward and backward compatibility with both the current industry-standard SnPb-based soldering processes and higher-temperature Pb-free processes. Pure tin is widely accepted by customers and suppliers of electronic devices in Europe, Asia and the US as the lead-free surface finish of choice to replace tin-lead. Also, it is backward compatible to reflow processes which adopt tin/lead (SnPb) solder paste. Please refer to JEDEC J-STD-020C for temperature setting. However, in the whole Pb-free soldering processes and materials, 100% pure tin (Sn) will all require from 245 °C to 260°C for proper soldering on boards, referring to JEDEC J-STD-020C as shown below.

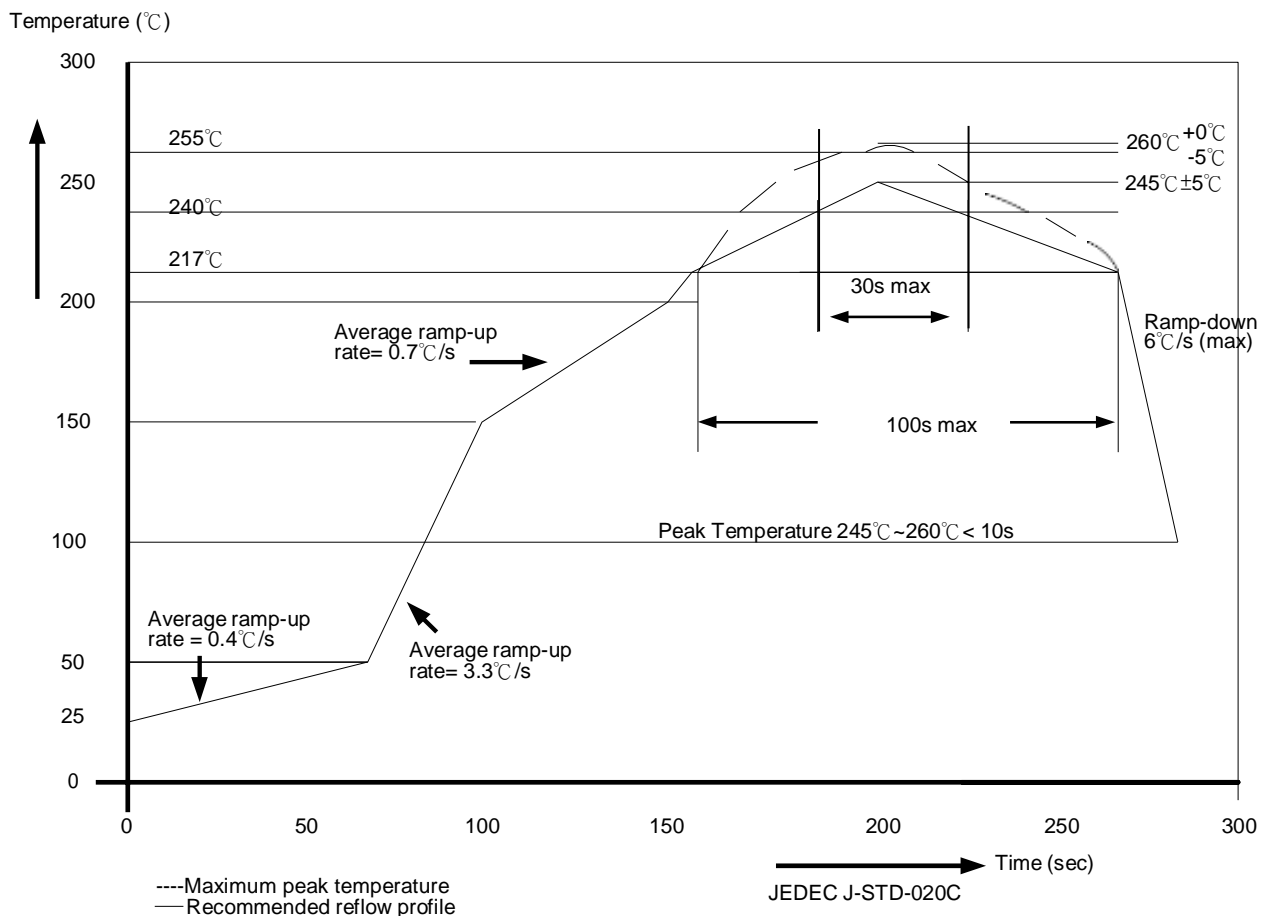

| Package Thickness | Volume mm <sup>3</sup><br><350 | Volume mm <sup>3</sup><br>350-2000 | Volume mm <sup>3</sup><br>≥ 2000 |
|-------------------|--------------------------------|------------------------------------|----------------------------------|
| <1.6mm            | 260 +0 °C                      | 260 +0 °C                          | 260 +0 °C                        |
| 1.6mm – 2.5mm     | 260 +0 °C                      | 250 +0 °C                          | 245 +0 °C                        |
| ≥ 2.5mm           | 250 +0 °C                      | 245 +0 °C                          | 245 +0 °C                        |

\*Note: For details, please refer to Macroblock's "Policy on Pb-free & Green Package".

## Package Outline

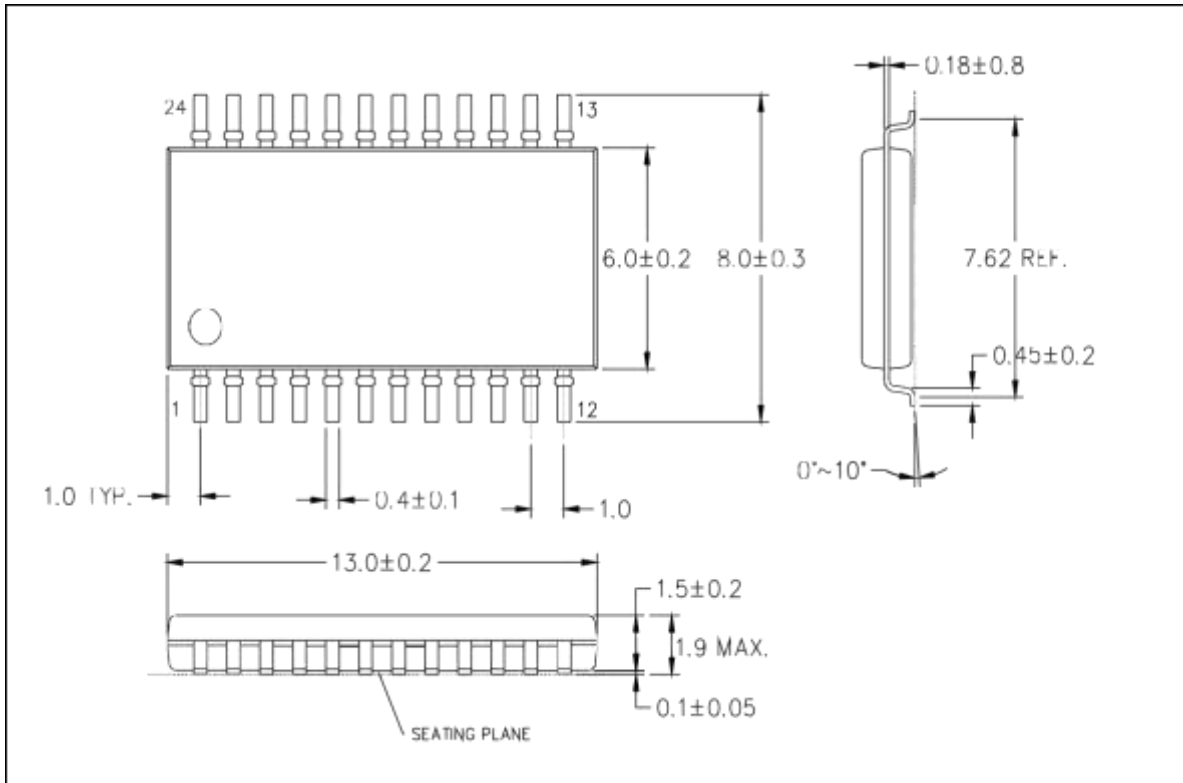

MBI5040GF Outline Drawing

Note: The unit for the outline drawing is mm.

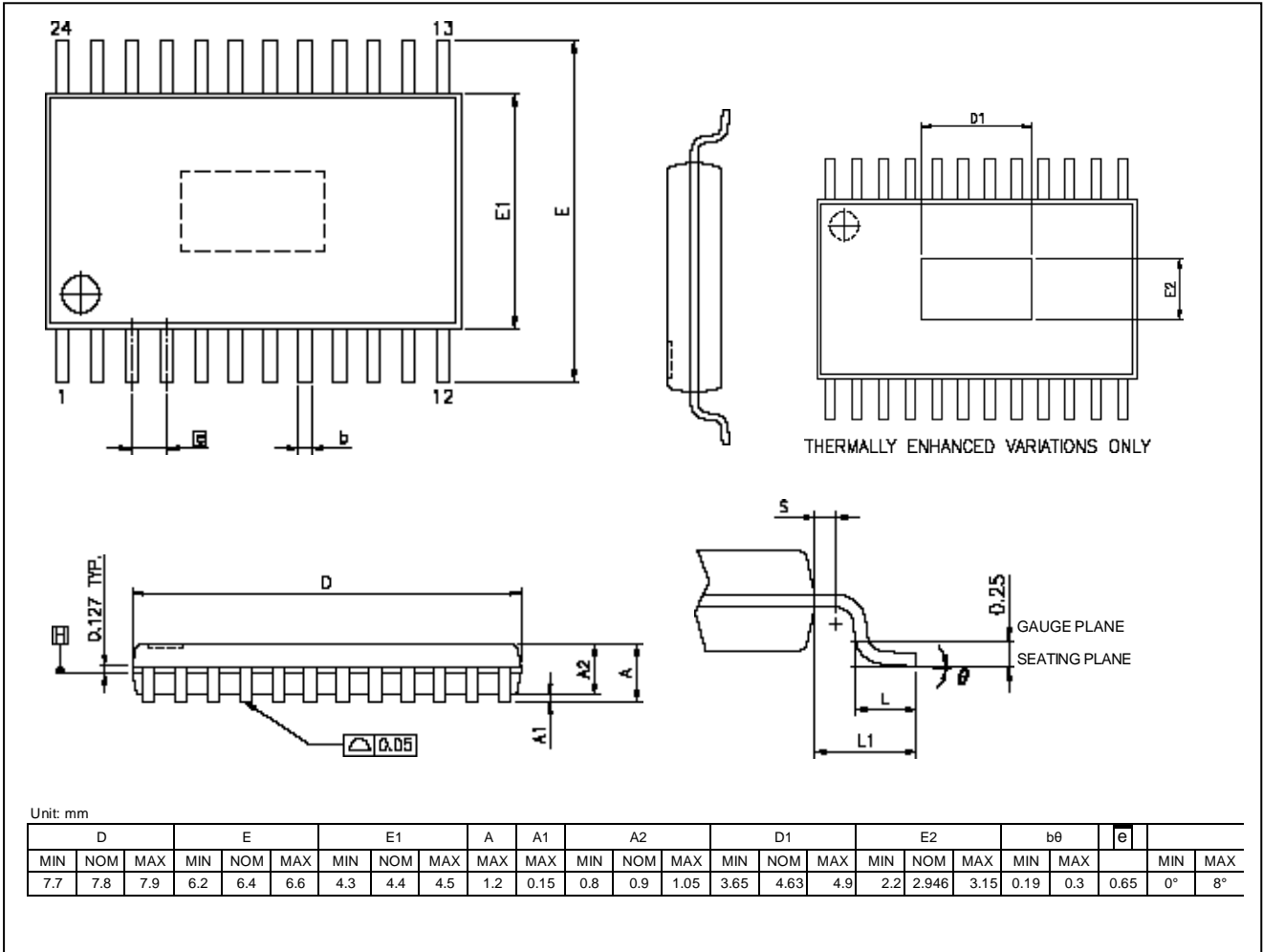

MBI5040 GTS Outline Drawing

Remark: The thermal pad size may exist a tolerance due to the manufacturing process, please use the maximum dimensions-D1(max.) x E2(max.) for the thermal pad layout. In addition, to avoid the short circuit risk, the vias or circuit traces shall not pass through the maximum area of thermal pad.

Note: The unit for the outline drawing is mm.

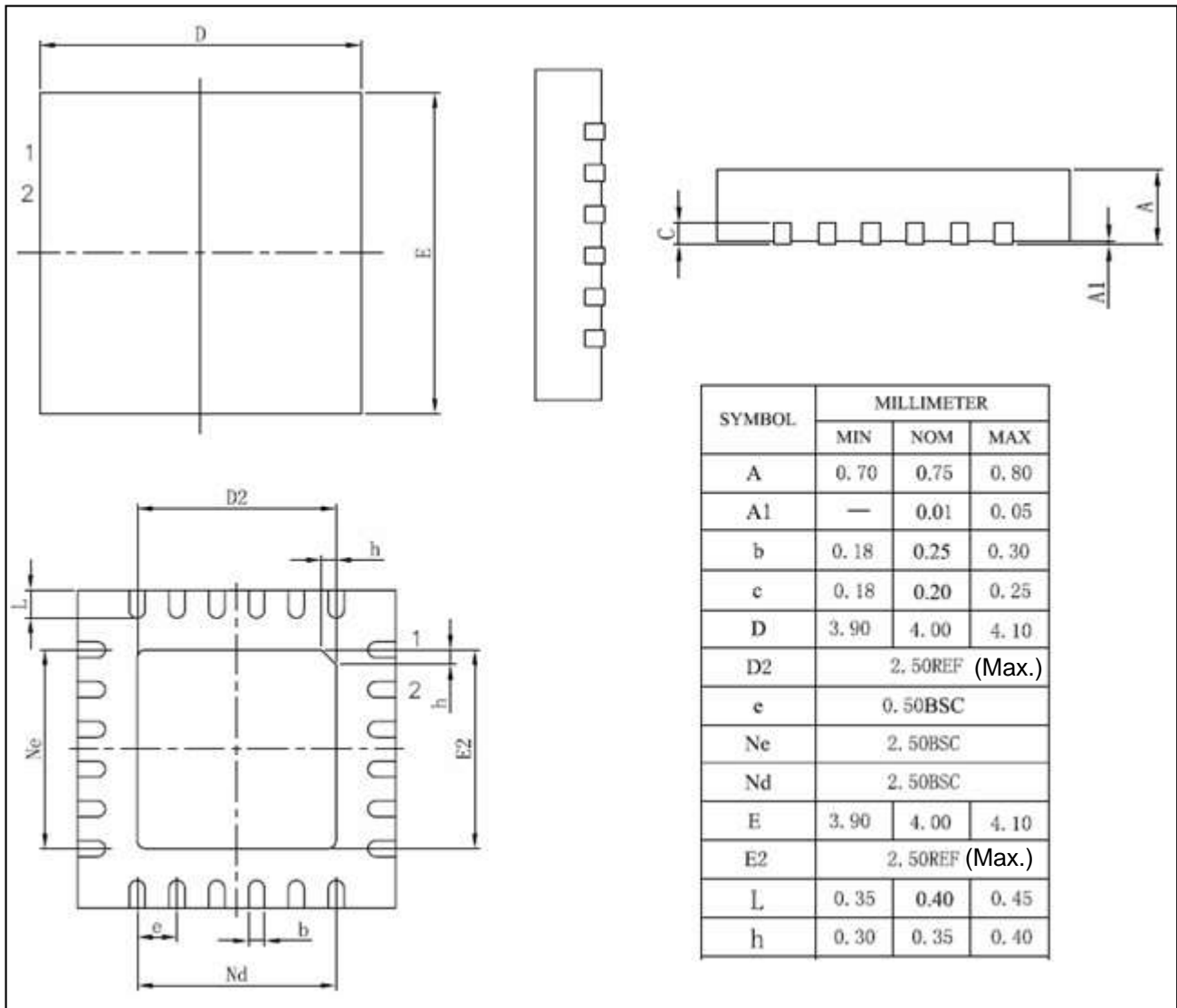

MBI5040 GFN Outline Drawing

Remark: The thermal pad size may exist a tolerance due to the manufacturing process, please use the maximum dimensions-D2(max. 2.50mm) x E2(max. 2.50mm) for the thermal pad layout. In addition, to avoid the short circuit risk, the vias or circuit traces shall not pass through the maximum area of thermal pad.

Note: The unit of the outline drawing is millimeter (mm).

## Product Top Mark Information

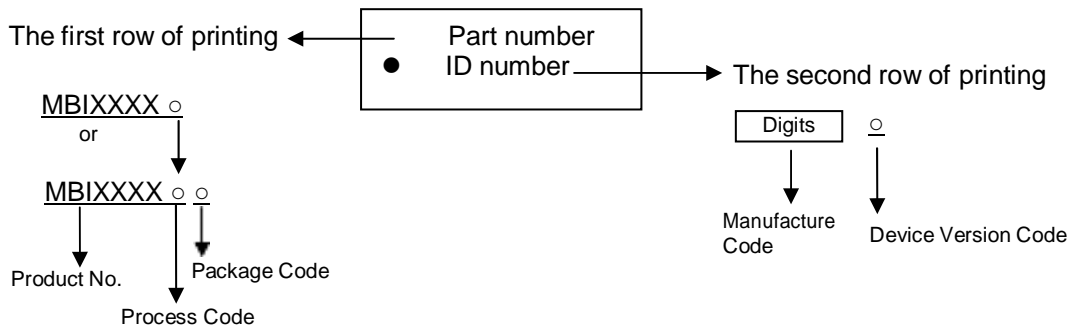

## Product Revision History

| Datasheet version | Device Version Code |
|-------------------|---------------------|
| VA.00             | A                   |
| VA.01             | A                   |
| VA.02             | A                   |

## Product Ordering Information

| Part Number  | RoHS Compliant<br>Package Type | Weight (g) |
|--------------|--------------------------------|------------|
| MBI5040GF-A  | SOP24L-300-1.00                | 0.282      |
| MBI5040GTS-A | TSSOP24L-173 -0.65             | 0.0967     |
| MBI5040GFN-A | QFN24L-4*4- 0.5                | 0.0379     |

\*Please place your order with the "**product ordering number**" information on your purchase order (PO).

# 16-Channel Constant Current LED Driver With 16-Bit PWM Control and Dot-Correction

## Disclaimer

Macroblock reserves the right to make changes, corrections, modifications, and improvements to their products and documents or discontinue any product or service without notice. Customers are advised to consult their sales representative for the latest product information before ordering. All products are sold subject to the terms and conditions supplied at the time of order acknowledgement, including those pertaining to warranty, patent infringement, and limitation of liability.

Macroblock's products are not designed to be used as components in device intended to support or sustain life or in military applications. Use of Macroblock's products in components intended for surgical implant into the body, or other applications in which failure of Macroblock's products could create a situation where personal death or injury may occur, is not authorized without the express written approval of the Managing Director of Macroblock.

Macroblock will not be held liable for any damages or claims resulting from the use of its products in medical and military applications.

Related technologies applied to the product are protected by patents. All text, images, logos and information contained on this document is the intellectual property of Macroblock. Unauthorized reproduction, duplication, extraction, use or disclosure of the above mentioned intellectual property will be deemed as infringement.