



The Automotive-Grade Device

Handbook



101 Innovation Drive
San Jose, CA 95134
www.altera.com

AUT5V1-3.4

© 2013 Altera Corporation. All rights reserved. ALTERA, ARRIA, CYCLONE, HARDCOPY, MAX, MEGACORE, NIOS, QUARTUS and STRATIX words and logos are trademarks of Altera Corporation and registered in the U.S. Patent and Trademark Office and in other countries. All other words and logos identified as trademarks or service marks are the property of their respective holders as described at www.altera.com/common/legal.html. Altera warrants performance of its semiconductor products to current specifications in accordance with Altera's standard warranty, but reserves the right to make changes to any products and services at any time without notice. Altera assumes no responsibility or liability arising out of the application or use of any information, product, or service described herein except as expressly agreed to in writing by Altera. Altera customers are advised to obtain the latest version of device specifications before relying on any published information and before placing orders for products or services.



Chapter 1. Introduction

Altera Automotive-Grade Devices	1-1
Altera Automotive Qualifications	1-2
Supported Devices	1-3
Document Revision History	1-3

Chapter 2. Cyclone V SoC Devices

Supported Automotive-Grade Devices	2-1
Device Ordering Codes	2-3
Quartus II Software Support	2-4
Power Analysis and Estimation	2-4
PowerPlay Early Power Estimator	2-4
PowerPlay Power Analyzer	2-5
DC and Timing Specifications	2-5
Pin-Out Information	2-6
Package and Board Layout Information	2-7
Document Revision History	2-7

Chapter 3. Cyclone V Devices

Supported Automotive-Grade Devices	3-1
Device Ordering Codes	3-3
Quartus II Software Support	3-4
Power Analysis and Estimation	3-5
PowerPlay Early Power Estimator	3-5
PowerPlay Power Analyzer	3-6
DC and Timing Specifications	3-6
Pin-Out Information	3-7
Package and Board Layout Information	3-7
Document Revision History	3-8

Chapter 4. Cyclone IV Devices

Supported Automotive-Grade Devices	4-1
Device Ordering Codes	4-3
Quartus II Software Support	4-3
Power Analysis and Estimation	4-4
PowerPlay Early Power Estimator	4-4
PowerPlay Power Analyzer	4-5
DC and Timing Specifications	4-5
Pin-Out Information	4-6
Package and Board Layout Information	4-6
Document Revision History	4-7

Chapter 5. MAX V Devices

Supported Automotive-Grade Devices	5-1
Device Ordering Codes	5-2
Quartus II Software Support	5-3
Power Analysis and Estimation	5-3
PowerPlay Early Power Estimator	5-3

PowerPlay Power Analyzer	5-4
DC and Timing Specifications	5-4
Pin-Out Information	5-5
Package and Board Layout Information	5-5
Document Revision History	5-5

Chapter 6. MAX II Devices

Supported Automotive-Grade Devices	6-1
Device Ordering Codes	6-2
Quartus II Software Support	6-2
Power Analysis and Estimation	6-3
PowerPlay Early Power Estimator	6-3
PowerPlay Power Analyzer	6-3
DC and Timing Specifications	6-4
Pin-Out Information	6-5
Package and Board Layout Information	6-5
Document Revision History	6-5

Chapter 7. HardCopy II Devices

Supported Automotive-Grade Devices	7-1
Device Ordering Codes	7-1
Quartus II Software Support	7-2
Power Analysis and Estimation	7-2
PowerPlay Early Power Estimator	7-2
PowerPlay Power Analyzer	7-3
DC and Timing Specifications	7-3
Pin-Out Information	7-4
Package and Board Layout Information	7-5
Document Revision History	7-5

Chapter 8. Cyclone III Devices (Legacy Support)

Supported Automotive-Grade Devices	8-1
Device Ordering Codes	8-2
Quartus II Software Support	8-2
Power Analysis and Estimation	8-3
PowerPlay Early Power Estimator	8-3
PowerPlay Power Analyzer	8-3
DC and Timing Specifications	8-4
Pin-Out Information	8-5
Package and Board Layout Information	8-5
Document Revision History	8-6

Chapter 9. Cyclone II Devices (Legacy Support)

Supported Automotive-Grade Devices	9-1
Device Ordering Codes	9-2
Quartus II Software Support	9-2
Power Analysis and Estimation	9-3
PowerPlay Early Power Estimator	9-3
PowerPlay Power Analyzer	9-4
DC and Timing Specifications	9-4
Pin-Out Information	9-5
Package and Board Layout Information	9-5
Document Revision History	9-5

Chapter 10. Cyclone Devices (Legacy Support)

Supported Automotive-Grade Devices	10-1
Device Ordering Codes	10-2
Quartus II Software Support	10-2
Power Analysis and Estimation	10-3
PowerPlay Early Power Estimator	10-3
PowerPlay Power Analyzer	10-4
DC and Timing Specifications	10-4
Pin-Out Information	10-5
Package and Board Layout Information	10-5
Document Revision History	10-5

Chapter 11. MAX 7000A Devices (Legacy Support)

Supported Automotive-Grade Devices	11-1
Device Ordering Codes	11-2
Quartus II Software Support	11-2
Power Analysis and Estimation	11-3
PowerPlay Early Power Estimator	11-3
PowerPlay Power Analyzer	11-3
DC and Timing Specifications	11-4
Pin-Out Information	11-4
Package and Board Layout Information	11-5
Document Revision History	11-5

Chapter 11. About this Handbook

How to Contact Altera	11-7
Typographic Conventions	11-7

Altera Automotive-Grade Devices

The Altera® automotive product portfolio consists of the best-in-class end-application solutions, devices, and development tools supporting the automotive industry. This selected group of automotive-grade devices provides engineers with the design flexibility and short time-to-market that programmable logic is well-known for, while meeting the high-quality standards and extended temperature range needed for automotive electronics.

Altera is the only supplier offering both programmable devices and structured ASICs. Whether you need a simple low-cost, low-power glue logic or a complex graphics controller solution driving your in-dash infotainment display, Altera has the reference designs and expertise to help you succeed in the market. Altera automotive solutions offer the following advantages:

- Reference designs or design examples for infotainment, driver assistance, hybrid engineer control units, and other electronic modules.
- 30–50% lower power consumption in Altera CPLDs and FPGAs compared to competitor products.
- Unique FPGA-to-structured-ASIC flow where Stratix® II devices are converted to HardCopy® II devices resulting in a quick prototyping process, rapid production ramp, and lower costs.
- Extensive range of on-chip functionalities and IP cores. Examples of on-chip functionalities include Dual ARM® A9 based processor subsystem, RAM blocks, digital signal processing (DSP) blocks, and phase-locked loops (PLLs). Examples of IP cores include the Nios® II 32-bit embedded soft processor, controller area network (CAN), and media-oriented systems transport (MOST).
- AEC-Q100 qualified devices, TS-16949 certified manufacturing sites, and production part approval process (PPAP) documentation.

 For more information about Altera automotive solutions, visit www.altera.com/end-markets/auto/aut-index.html.

This chapter contains the following sections:

- “Altera Automotive Qualifications” on page 1–2
- “Supported Devices” on page 1–3

Altera Automotive Qualifications

The Altera automotive-grade devices feature junction temperature range support from -40°C to 125°C (up to 130°C for MAX[®] 7000AE CPLDs) with $T_{\text{AMBIENT}} = 125^{\circ}\text{C}$ (or more) available on selected devices.

Safety practices are becoming more regulated as industries adopt a standardized set of procedures for designing and testing products. ISO-26262 is a risk-based safety standard, where the risk of hazardous operational situations are qualitatively assessed and safety measures are defined to avoid or control systematic failures and random hardware failures, or mitigate their effects. Altera is the first and only programmable logic supplier whose products, intellectual property (IP), tools and tool flow have been certified for IEC-61508 functional safety, the basis for the ISO-26262 automotive specification, helping you to save 18–24 months of development time in certifying safety applications.

Altera is a member of the Automotive Electronics Council (AEC) and adheres to the automotive quality standard, AEC-Q100.

 For device-specific details about the AEC-Q100 qualification testing, contact Altera at customer-quality@altera.com.

 For more information about the AEC-Q100 qualification, refer to www.aecouncil.com/AECDocuments.html.

Altera is also an ISO-9001 certified supplier. Altera's manufacturing fab partners (TSMC and Wafertech) and its packaging and test partners (ASE and AMKOR) producing automotive-grade products are registered and certified to the ISO and TS-16949 quality standards.

 To view the certificates, refer to www.altera.com/end-markets/auto/quality/aut-quality.html.

Altera performs stringent reliability qualification and monitoring on a product family basis. Altera devices exceed the reliability requirements established by the Electronic Industries Alliance (EIA) and the Joint Electron Device Engineering Council (JEDEC). JEDEC qualification tests ensure that Altera devices meet or exceed these reliability standards.

 For more information about the reliability qualification and monitoring programs for Altera products, refer to the Altera *Reliability Report*.

All Altera automotive-grade devices have a PPAP document.

 For device-specific details about the PPAP documentation, contact Altera at customer-quality@altera.com.

Supported Devices

Altera is the only programmable logic supplier offering automotive-grade devices in the CPLD, FPGA, system on a chip (SoC), and ASIC semiconductor IC categories (refer to [Table 1-1](#)). These devices are perfectly suited for high-temperature environments such as automotive driver assist, infotainment, and e-vehicle.

[Table 1-1](#) lists the product families offering automotive-grade devices.

Table 1-1. The Altera Automotive-Grade Products

Category	Product Family	Description
IC, SoC	Cyclone® V SoC	Low-cost, low-power, user-customizable ARM-based SoC FPGAs
IC, FPGA	Cyclone V	Low-cost, low-power, feature-rich 28 nm FPGAs
IC, FPGA	Cyclone IV	Low-cost, low-power, feature-rich 60 nm FPGAs (1.2 V)
IC, CPLD	MAX V	High-density, low-power glue logic CPLDs (1.8 V)
IC, CPLD	MAX II	High-density, low-power glue logic CPLDs (3.3 V, 2.5 V)
IC, ASIC	HardCopy	Low-cost, multi-million-gate ASICs. Benefit from unique combination of FPGA prototyping and optional migration to automotive-grade ASIC
Volume Production Support for Legacy Device Families		
IC, FPGA	Cyclone III	Low-cost, feature-rich 65 nm FPGAs
IC, FPGA	Cyclone II	Low-cost, feature-rich 90 nm FPGAs
IC, FPGA	Cyclone	Low-cost, glue logic 130 nm FPGAs
IC, CPLD	MAX 7000AE	High-performance, glue logic CPLDs (5-V I/O compatible)

Document Revision History

[Table 1-2](#) lists the revision history for this chapter.

Table 1-2. Document Revision History

Date	Version	Changes
September 2013	3.4	No update.
June 2013	3.3	No update.
May 2013	3.2	No update.
February 2013	3.1	No update.
January 2013	3.0	<ul style="list-style-type: none"> ■ Updated information in “Altera Automotive Qualifications” and “Supported Devices” sections. ■ Updated Table 1-1 to include Cyclone V SoC and Cyclone V devices.
May 2011	2.0	<ul style="list-style-type: none"> ■ Updated Table 1-1 to include MAX V devices. ■ Template conversion. ■ Minor text edits.
March 2010	1.2	Removed Referenced Documents section.
October 2008	1.1	Converted to new template.
February 2008	1.0	Initial release.

Supported Automotive-Grade Devices

Altera offers Cyclone® V system on a chip (SoC) devices in automotive-grade variants. These devices are available in the –A7 speed grade.

Table 2–1 lists the automotive-grade devices in the Cyclone V SoC devices.

Table 2–1. Automotive-Grade in Cyclone V SoC Devices

Device Ordering Code	Package
5CSEBA2U19A7N	484-pin UBGA
5CSEBA2U23A7N	672-pin UBGA
5CSEMA2U23A7N	672-pin UBGA
5CSEBA4U19A7N	484-pin UBGA
5CSEBA4U23A7N	672-pin UBGA
5CSEMA4U23A7N	672-pin UBGA
5CSEBA5U19A7N	484-pin UBGA
5CSEBA5U23A7N	672-pin UBGA
5CSEMA5U23A7N	672-pin UBGA
5CSEMA5F31A7N	896-pin FBGA
5CSEBA6U19A7N	484-pin UBGA
5CSEBA6U23A7N	672-pin UBGA
5CSEMA6U23A7N	672-pin UBGA
5CSEMA6F31A7N	896-pin FBGA
5CSXFC2C6U23A7N	672-pin UBGA
5CSXFC4C6U23A7N	672-pin UBGA
5CSXFC5C6U23A7N	672-pin UBGA
5CSXFC6C6U23A7N	672-pin UBGA

Note to Table 2–1:

- (1) Other automotive-grade product line/package combinations or ordering codes might be available upon request. Consult your Altera sales representative to submit your request.

Table 2–2 and Table 2–3 show the package options and maximum user I/Os in the Cyclone V SoC devices.

Table 2–2. Package Options and Maximum User I/Os in Cyclone V SE Devices (Part 1 of 2)

Package Type/ Pin Count	Ball Spacing (mm)	Dimensions (mm)	Product Line			
			5CSEA2 (25K LEs)	5CSEA4 (40K LEs)	5CSEA5 (85K LEs)	5CSEA6 (110K LEs)
			FPGA I/Os / HPS I/Os			
UBGA-484	0.8	19 x 19	66 / 161 ⁽¹⁾	66 / 161 ⁽¹⁾	66 / 161 ⁽¹⁾	66 / 161 ⁽¹⁾
UBGA-672	0.8	23 x 23	145 / 188 ⁽¹⁾	145 / 188 ⁽¹⁾	145 / 188 ⁽¹⁾	145 / 188 ⁽¹⁾

Table 2-2. Package Options and Maximum User I/Os in Cyclone V SE Devices (Part 2 of 2)

Package Type/ Pin Count	Ball Spacing (mm)	Dimensions (mm)	Product Line			
			5CSEA2 (25K LEs)	5CSEA4 (40K LEs)	5CSEA5 (85K LEs)	5CSEA6 (110K LEs)
			FPGA I/Os / HPS I/Os			
FBGA-896	1.0	31 x 31	—	—	288 / 188 ⁽¹⁾	288 / 188 ⁽¹⁾

Note to Table 2-2:

(1) Package options available with automotive-grade variants.

Table 2-3. Package Options and Maximum User I/Os in Cyclone V SX Devices

Package Type/ Pin Count	Ball Spacing (mm)	Dimensions (mm)	Product Line			
			5CSXC2 (25K LEs)	5CSXC4 (40K LEs)	5CSXC5 (85K LEs)	5CSXC6 (110K LEs)
			FPGA I/Os / HPS I/Os / XCVRs			
UBGA-672	0.8	23 x 23	145 / 188 / 6 ⁽¹⁾	145 / 188 / 6 ⁽¹⁾	145 / 188 / 6 ⁽¹⁾	145 / 188 / 6 ⁽¹⁾
FBGA-896	1.0	31 x 31	—	—	288 / 188 / 9 ⁽²⁾	288 / 188 / 9 ⁽²⁾

Notes to Table 2-3:

(1) Package options available with automotive-grade variants.

(2) These package options are not currently available in automotive-grade but might become available upon request. Consult your Altera sales representative to submit your request.

This chapter contains the following sections:

- “Device Ordering Codes” on page 2-3
- “Quartus II Software Support” on page 2-4
- “Power Analysis and Estimation” on page 2-4
- “DC and Timing Specifications” on page 2-5
- “Pin-Out Information” on page 2-6
- “Package and Board Layout Information” on page 2-7

Device Ordering Codes

Figure 2-1 and Figure 2-2 show the ordering codes for automotive-grade devices offered in the Cyclone V SoC devices.

 For more information about a specific package, refer to the *Package Information Datasheet for Altera Devices*.

Figure 2-1. Automotive-Grade Ordering Information for Cyclone V SE Devices

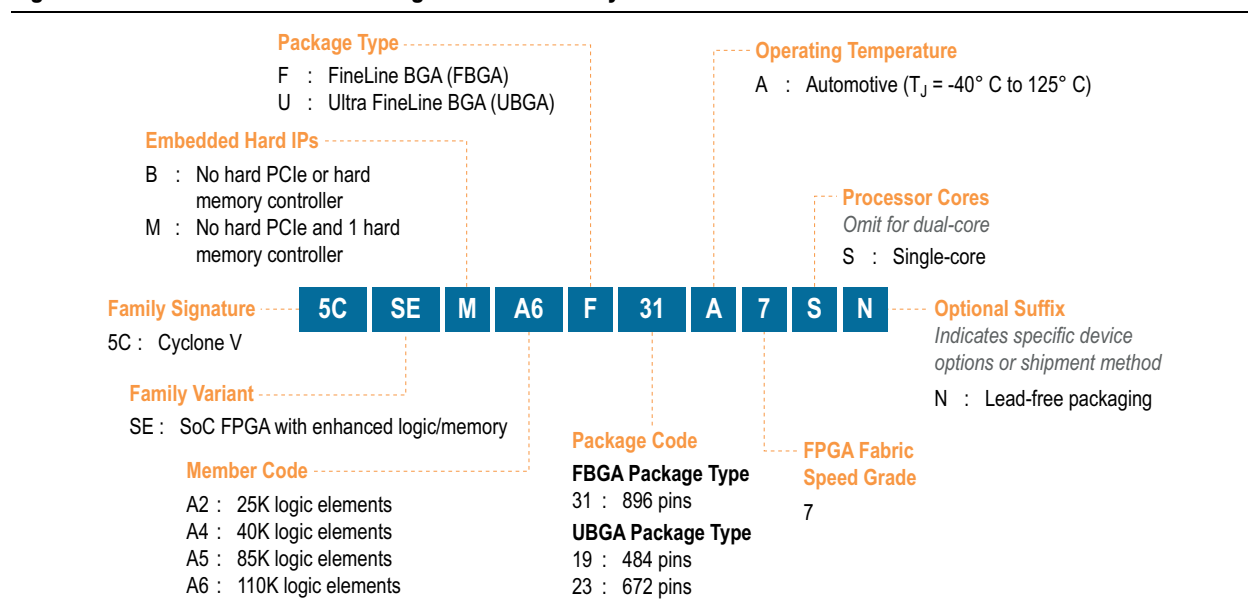
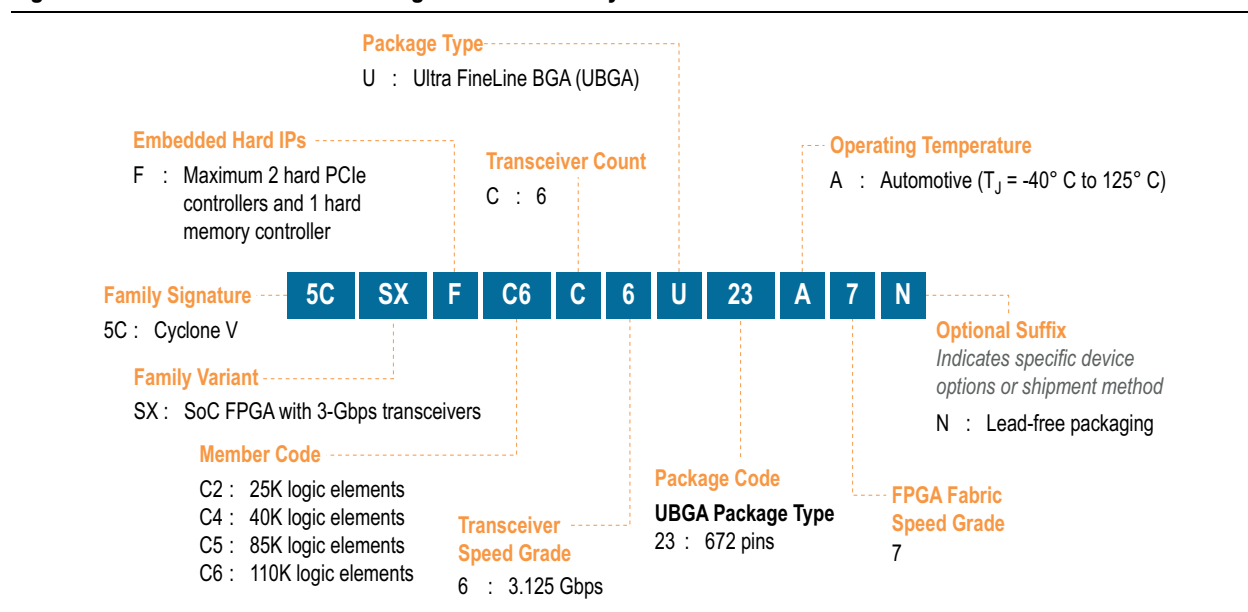



Figure 2-2. Automotive-Grade Ordering Information for Cyclone V SX Devices



Quartus II Software Support

The Altera® Quartus® II design software supports the Cyclone V SoC devices in the automotive temperature range. The Quartus II software provides a comprehensive environment for SoC design. It also includes HDL and schematic design entry, compilation and logic synthesis, full simulation and advanced timing analysis, SignalTap™ II logic analyzer, and device configuration.

 For more information about the Quartus II software features, refer to the [Quartus II Handbook](#).

To target an automotive-grade Cyclone V SoC device in your design in the Quartus II software, follow these steps:

1. On the Assignments menu, click **Device**. The **Settings** dialog box appears.
2. In the **Family** drop-down list, select **Cyclone V**.
3. Under Target device, select **Specific device selected in 'Available devices' list**.
4. In the **Available devices** list, select the appropriate ordering code, as listed in [Table 2-1](#).

 The Quartus II software does not show the “N” suffix, which indicates a lead-free device. For example, the 5CSXFC2C6U23A7N device is shown only as 5CSXFC2C6U23A7.

5. Click **OK**.

 Support for the automotive-grade Cyclone V SoC devices is only available in the Quartus II software version 12.1 and later.

Power Analysis and Estimation

Altera provides the following power analysis and estimation tools for your design:

- “PowerPlay Early Power Estimator”
- “PowerPlay Power Analyzer”

PowerPlay Early Power Estimator

The PowerPlay Early Power Estimator (EPE) is a power estimation tool that helps you estimate the power consumption of your design during the system planning phase for proper power supply planning and consideration. The EPE allows you to enter design information based on architectural features and calculates the power consumed by each architectural feature. Inputs to the EPE are environmental conditions and device resources (such as clock frequency, RAM blocks, and digital signal processing [DSP] blocks) that you expect to use in your design. The EPE then calculates the static and dynamic power, current estimates, and thermal analysis for the design.

You can either enter the design information manually into the spreadsheet or import a power estimator file of a fully or partially completed design from the Quartus II software. After importing a file, you can edit some of the input parameters including V_{CCINT} , ambient temperature, airflow, clock frequency, and toggle percentage to suit your system requirements.



The value obtained from the EPE is only an estimation and should not be used as a specification. The accuracy of the EPE results depends on how close your input of the design information into the EPE resembles that of the final design.



For more information about the EPE, and how to generate and import the power estimator file, refer to the *PowerPlay Early Power Estimator User Guide*.

PowerPlay Power Analyzer

The PowerPlay Power Analyzer tool in the Quartus II software is a power analysis tool that helps you calculate your design power consumption accurately to ensure thermal and power supply budgets are not violated after your design is complete. The PowerPlay Power Analyzer tool requires your design to be synthesized and fitted to the target device. Availability of information such as design resources, how the design is placed and routed on the target device, and the I/O standards assigned to each I/O cell allow the PowerPlay Power Analyzer tool to provide accurate power estimation.

The process of using the PowerPlay Power Analyzer tool consists of three parts—specifying sources of input data, specifying operating conditions, and running the PowerPlay Power Analyzer tool.

The input data consists of the signal activities data (toggle rates and static probabilities) of the compiled design. Signal activity data can be derived from simulation results, user assignment in the Assignment Editor, user-defined default toggle rate, and vectorless estimation.

The operating conditions include device power characteristic, ambient and junction temperature, cooling solution, and board thermal model, all of which can be set in the Quartus II software.

The PowerPlay Power Analyzer tool calculates the dynamic, static and I/O thermal power consumption, current consumed from voltage source, a summary of the signal activities used for analysis, and a confidence metric that reflects the overall quality of the data sources for the signal activities.



For more information about the PowerPlay Power Analyzer tool, refer to the *PowerPlay Power Analysis* chapter in volume 3 of the *Quartus II Handbook*.

DC and Timing Specifications

The automotive-grade Cyclone V SoC devices have the same absolute maximum ratings, recommended operating conditions, and DC electrical characteristics as those published for the Cyclone V SoC devices in the *Cyclone V Device Datasheet*.

The on-chip series termination (R_S OCT) specifications of the automotive-grade Cyclone V SoC devices are the same as those of their corresponding industrial-grade Cyclone V SoC devices. The switching characteristics of the automotive-grade devices are the same as those of the Cyclone V SoC devices with -8 speed grade published in the *Cyclone V Device Datasheet*.



For the timing specifications of the automotive-grade Cyclone V SoC devices, refer to the *Cyclone V Device Datasheet*.

The automotive-grade devices meet these timing specifications over the automotive temperature range ($T_j = -40^\circ\text{C}$ to 125°C).

Table 2-4 lists the automotive-grade ordering codes and their equivalent timing specifications for Cyclone V SoC devices.

Table 2-4. Automotive-Grade Ordering Codes and Their Equivalent Timing Specifications for Cyclone V SoC Devices

Automotive-Grade Device Ordering Code	Device Timing Specification		
	Device	Junction Temperature Range	Speed Grade
5CSEBA2U19A7N	5CSEBA2	-40°C to 125°C	-7
5CSEBA2U23A7N	5CSEBA2	-40°C to 125°C	-7
5CSEMA2U23A7N	5CSEMA2	-40°C to 125°C	-7
5CSEBA4U19A7N	5CSEBA4	-40°C to 125°C	-7
5CSEBA4U23A7N	5CSEBA4	-40°C to 125°C	-7
5CSEMA4U23A7N	5CSEMA4	-40°C to 125°C	-7
5CSEBA5U19A7N	5CSEBA5	-40°C to 125°C	-7
5CSEBA5U23A7N	5CSEBA5	-40°C to 125°C	-7
5CSEMA5U23A7N	5CSEMA5	-40°C to 125°C	-7
5CSEMA5F31A7N	5CSEMA5	-40°C to 125°C	-7
5CSEBA6U19A7N	5CSEBA6	-40°C to 125°C	-7
5CSEBA6U23A7N	5CSEBA6	-40°C to 125°C	-7
5CSEMA6U23A7N	5CSEMA6	-40°C to 125°C	-7
5CSEMA6F31A7N	5CSEMA6	-40°C to 125°C	-7
5CSXFC2C6U23A7N	5CSXFC2	-40°C to 125°C	-7
5CSXFC4C6U23A7N	5CSXFC4	-40°C to 125°C	-7
5CSXFC5C6U23A7N	5CSXFC5	-40°C to 125°C	-7
5CSXFC6C6U23A7N	5CSXFC6	-40°C to 125°C	-7

Note to Table 2-4:

- (1) Other automotive-grade product line/package combinations or ordering codes might be available upon request. Consult your Altera sales representative to submit your request.

Pin-Out Information



For more information about the Cyclone V SoC device pin-outs, refer to the *Cyclone V Device Pin-Out Files* page.

Package and Board Layout Information

- For package-related information (for example, dimensions and thermal resistance values) on Cyclone V SoC devices, refer to the *Package Information Datasheet for Altera Devices*.
- For PCB design guidelines, refer to *AN114: Designing With High-Density BGA Packages for Altera Devices*.
- If you are designing PCBs with the Cadence OrCAD capture component information system, you can download the symbol libraries from the [Cadence Capture CIS and Allegro PCB Symbols and Footprints](#) page.

Document Revision History

Table 2-5 lists the revision history for this chapter.

Table 2-5. Document Revision History

Date	Version	Changes
September 2013	3.4	No update.
June 2013	3.3	No update.
May 2013	3.2	No update.
February 2013	3.1	Updated Table 2-2 and Table 2-3.
January 2013	3.0	Initial release.

Supported Automotive-Grade Devices

Altera offers Cyclone® V devices in automotive-grade variants. These devices are available in the –A7 speed grade.

Table 3–1 lists the automotive-grade devices in the Cyclone V device family.

Table 3–1. Automotive-Grade in Cyclone V Devices

Device Ordering Code	Package
5CEBA2F17A7N	256-pin FBGA
5CEBA4F17A7N	256-pin FBGA
5CEFA2U19A7N	484-pin UBGA
5CEFA4U19A7N	484-pin UBGA
5CEFA5U19A7N	484-pin UBGA
5CEFA7U19A7N	484-pin UBGA
5CEFA9U19A7N	484-pin UBGA
5CGXFC3B6U15A7N	324-pin UBGA
5CGXFC3B6U19A7N	484-pin UBGA
5CGXFC4C6U19A7N	484-pin UBGA
5CGXFC5C6U19A7N	484-pin UBGA
5CGXFC7C6U19A7N	484-pin UBGA
5CGXFC9A6U19A7N	484-pin UBGA
5CGTFD5C5U19A7N	484-pin UBGA
5CGTFD7C5U19A7N	484-pin UBGA
5CGTFD9A5U19A7N	484-pin UBGA

Note to Table 3–1:

- (1) Other automotive-grade product line/package combinations or ordering codes might be available upon request. Consult your Altera sales representative to submit your request.

Table 3–2 through Table 3–4 show the package options and maximum user I/Os in the Cyclone V devices.

Table 3–2. Package Options and Maximum User I/Os in Cyclone V E Devices (Part 1 of 2)

Package Type/ Pin Count	Ball Spacing (mm)	Dimensions (mm)	Product Line				
			5CEA2 (25K LEs)	5CEA4 (49K LEs)	5CEA5 (77K LEs)	5CEA7 (149.5K LEs)	5CEA9 (301K LEs)
			I/Os				
FBGA-256	1.0	17 x 17	128 ⁽¹⁾	128 ⁽¹⁾	—	—	—
UBGA-324	0.8	15 x 15	176 ⁽²⁾	176 ⁽²⁾	—	—	—
UBGA-484	0.8	19 x 19	224 ⁽¹⁾	224 ⁽¹⁾	224 ⁽¹⁾	240 ⁽¹⁾	—
FBGA-484	1.0	23 x 23	224 ⁽²⁾	224 ⁽²⁾	240 ⁽²⁾	240 ⁽²⁾	224 ⁽²⁾

Table 3-2. Package Options and Maximum User I/Os in Cyclone V E Devices (Part 2 of 2)

Package Type/ Pin Count	Ball Spacing (mm)	Dimensions (mm)	Product Line				
			5CEA2 (25K LEs)	5CEA4 (49K LEs)	5CEA5 (77K LEs)	5CEA7 (149.5K LEs)	5CEA9 (301K LEs)
			I/Os				
FBGA-672	1.0	27 x 27	—	—	—	336 ⁽²⁾	336 ⁽²⁾
FBGA-896	1.0	31 x 31	—	—	—	480 ⁽²⁾	480 ⁽²⁾

Notes to Table 3-2:

- (1) Package options available with automotive-grade variants.
- (2) These package options are not currently available in automotive-grade but might become available upon request. Consult your Altera sales representative to submit your request.

Table 3-3. Package Options and Maximum User I/Os in Cyclone V GX Devices

Package Type/ Pin Count	Ball Spacing (mm)	Dimensions (mm)	Product Line				
			5CGXC3 (31.5K LEs)	5CGXC4 (50K LEs)	5CGXC5 (77K LEs)	5CGXC7 (149.5K LEs)	5CGXC9 (301K LEs)
			I/Os / XCVRs				
UBGA-324	0.8	15 x 15	144 / 3 ⁽¹⁾	—	—	—	—
UBGA-484	0.8	19 x 19	208 / 3 ⁽¹⁾	224 / 6 ⁽¹⁾	224 / 6 ⁽¹⁾	240 / 6 ⁽¹⁾	—
FBGA-484	1.0	23 x 23	208 / 3 ⁽²⁾	240 / 6 ⁽²⁾	240 / 6 ⁽²⁾	240 / 6 ⁽²⁾	224 / 6 ⁽²⁾
FBGA-672	1.0	27 x 27	—	336 / 6 ⁽²⁾	336 / 6 ⁽²⁾	336 / 9 ⁽²⁾	336 / 9 ⁽²⁾
FBGA-896	1.0	31 x 31	—	—	—	480 / 9 ⁽²⁾	480 / 12 ⁽²⁾
FBGA-1152	1.0	35 x 35	—	—	—	—	560 / 12 ⁽²⁾

Notes to Table 3-3:

- (1) Package options available with automotive-grade variants.
- (2) These package options are not currently available in automotive-grade but might become available upon request. Consult your Altera sales representative to submit your request.

Table 3-4. Package Options and Maximum User I/Os in Cyclone V GT Devices

Package Type/ Pin Count	Ball Spacing (mm)	Dimensions (mm)	Product Line		
			5CGTD5 (77K LEs)	5CGTD7 (149.5K LEs)	5CGTD9 (301K LEs)
			I/Os / XCVRs		
UBGA-484	0.8	19 x 19	224 / 6 ⁽¹⁾	240 / 6 ⁽¹⁾	—
FBGA-484	1.0	23 x 23	240 / 6 ⁽²⁾	240 / 6 ⁽²⁾	224 / 6 ⁽²⁾
FBGA-672	1.0	27 x 27	336 / 6 ⁽²⁾	336 / 9 ⁽²⁾	336 / 9 ⁽²⁾
FBGA-896	1.0	31 x 31	—	480 / 9 ⁽²⁾	480 / 12 ⁽²⁾
FBGA-1152	1.0	35 x 35	—	—	560 / 12 ⁽²⁾

Notes to Table 3-4:

- (1) Package options available with automotive-grade variants.
- (2) These package options are not currently available in automotive-grade but might become available upon request. Consult your Altera sales representative to submit your request.

This chapter contains the following sections:

- “Device Ordering Codes” on page 3-3
- “Quartus II Software Support” on page 3-4
- “Power Analysis and Estimation” on page 3-5
- “DC and Timing Specifications” on page 3-6
- “Pin-Out Information” on page 3-7
- “Package and Board Layout Information” on page 3-7

Device Ordering Codes

Figure 3-1 through Figure 3-3 show the ordering codes for automotive-grade devices offered in the Cyclone V device family.

 For more information about a specific package, refer to the *Package Information Datasheet for Altera Devices*.

Figure 3-1. Automotive-Grade Ordering Information for Cyclone V E Devices

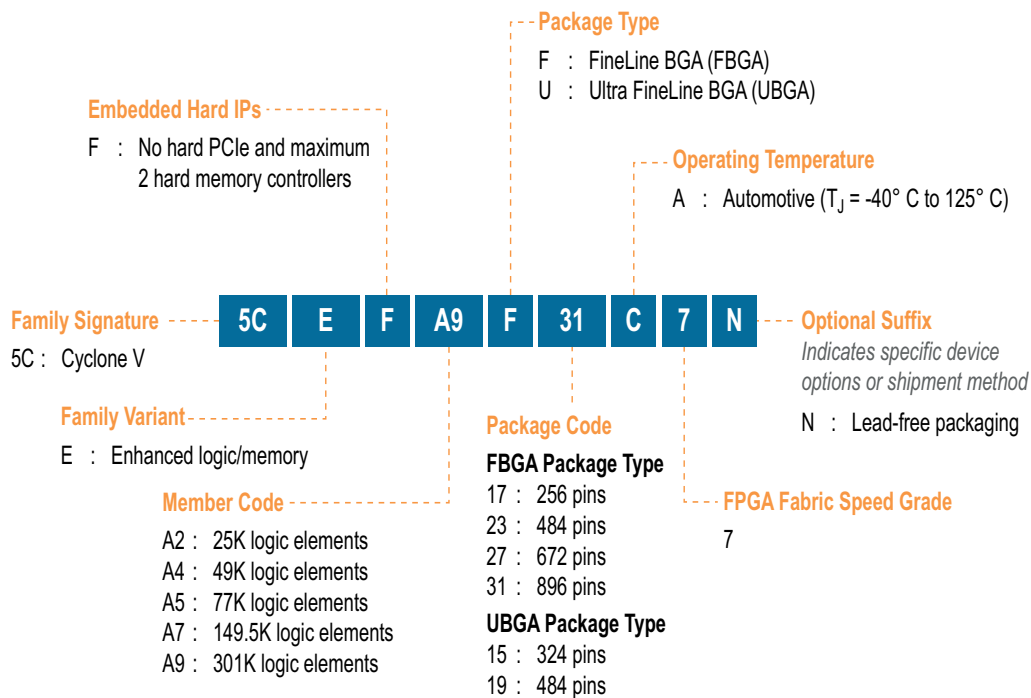

Figure 3-2. Automotive-Grade Ordering Information for Cyclone V GX Devices

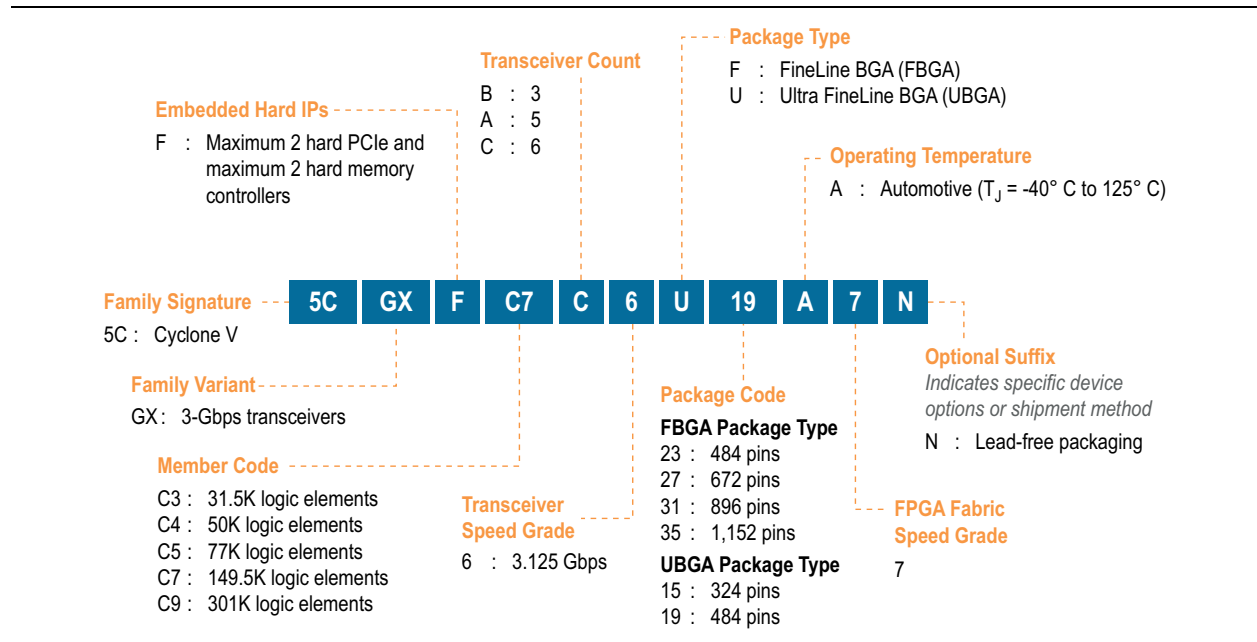
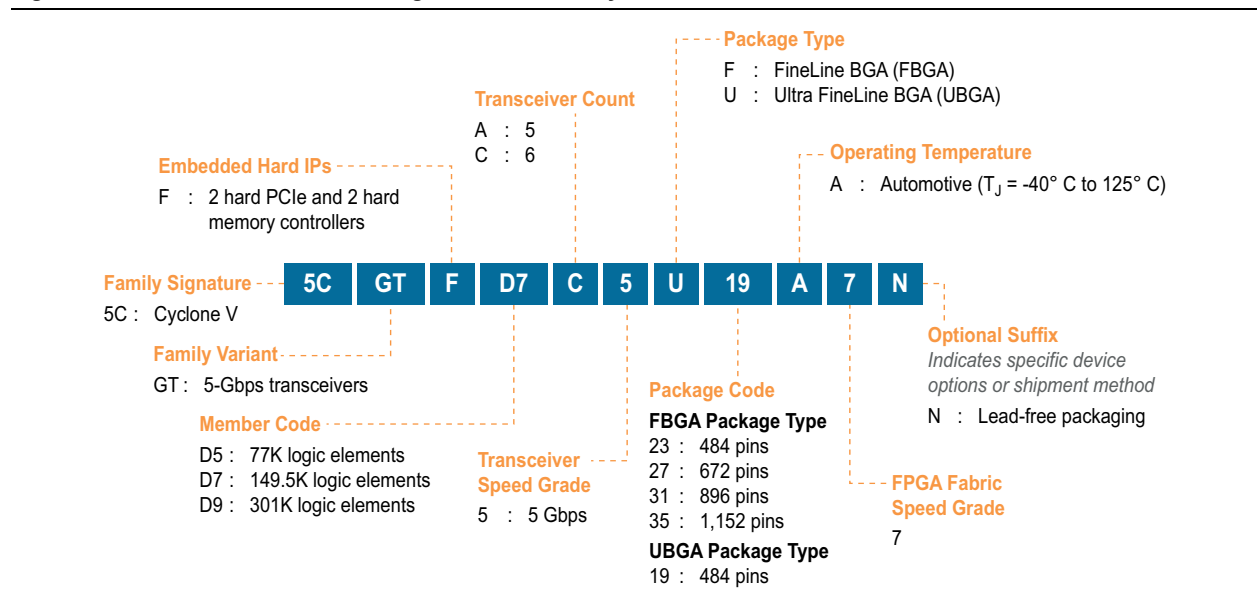



Figure 3-3. Automotive-Grade Ordering Information for Cyclone V GT Devices



Quartus II Software Support

The Altera® Quartus® II design software supports the Cyclone V devices in the automotive temperature range. The Quartus II software provides a comprehensive environment for system on a chip (SoC) design. It also includes HDL and schematic design entry, compilation and logic synthesis, full simulation and advanced timing analysis, SignalTap™ II logic analyzer, and device configuration.

 For more information about the Quartus II software features, refer to the *Quartus II Handbook*.

To target an automotive-grade Cyclone V device in your design in the Quartus II software, follow these steps:

1. On the Assignments menu, click **Device**. The **Settings** dialog box appears.
2. In the **Family** drop-down list, select **Cyclone V**.
3. Under Target device, select **Specific device selected in 'Available devices' list**.
4. In the **Available devices** list, select the appropriate ordering code, as listed in [Table 3-1](#).

 The Quartus II software does not show the “N” suffix, which indicates a lead-free device. For example, the 5CGXFC3B6U15A7N device is shown only as 5CGXFC3B6U15A7.

5. Click **OK**.

 Support for the automotive-grade Cyclone V devices is only available in the Quartus II software version 11.1 and later.

Power Analysis and Estimation

Altera provides the following power analysis and estimation tools for your design:

- “PowerPlay Early Power Estimator”
- “PowerPlay Power Analyzer”

PowerPlay Early Power Estimator

The PowerPlay Early Power Estimator (EPE) is a power estimation tool that helps you estimate the power consumption of your design during the system planning phase for proper power supply planning and consideration. The EPE allows you to enter design information based on architectural features and calculates the power consumed by each architectural feature. Inputs to the EPE are environmental conditions and device resources (such as clock frequency, RAM blocks, and digital signal processing [DSP] blocks) that you expect to use in your design. The EPE then calculates the static and dynamic power, current estimates, and thermal analysis for the design.

You can either enter the design information manually into the spreadsheet or import a power estimator file of a fully or partially completed design from the Quartus II software. After importing a file, you can edit some of the input parameters including V_{CCINT} , ambient temperature, airflow, clock frequency, and toggle percentage to suit your system requirements.

 The value obtained from the EPE is only an estimation and should not be used as a specification. The accuracy of the EPE results depends on how close your input of the design information into the EPE resembles that of the final design.

 For more information about the EPE, and how to generate and import the power estimator file, refer to the *PowerPlay Early Power Estimator User Guide*.

PowerPlay Power Analyzer

The PowerPlay Power Analyzer tool in the Quartus II software is a power analysis tool that helps you calculate your design power consumption accurately to ensure thermal and power supply budgets are not violated after your design is complete. The PowerPlay Power Analyzer tool requires your design to be synthesized and fitted to the target device. Availability of information such as design resources, how the design is placed and routed on the target device, and the I/O standards assigned to each I/O cell allow the PowerPlay Power Analyzer tool to provide accurate power estimation.

The process of using the PowerPlay Power Analyzer tool consists of three parts—specifying sources of input data, specifying operating conditions, and running the PowerPlay Power Analyzer tool.

The input data consists of the signal activities data (toggle rates and static probabilities) of the compiled design. Signal activity data can be derived from simulation results, user assignment in the Assignment Editor, user-defined default toggle rate, and vectorless estimation.

The operating conditions include device power characteristic, ambient and junction temperature, cooling solution, and board thermal model, all of which can be set in the Quartus II software.

The PowerPlay Power Analyzer tool calculates the dynamic, static and I/O thermal power consumption, current consumed from voltage source, a summary of the signal activities used for analysis, and a confidence metric that reflects the overall quality of the data sources for the signal activities.



For more information about the PowerPlay Power Analyzer tool, refer to the *PowerPlay Power Analysis* chapter in volume 3 of the *Quartus II Handbook*.

DC and Timing Specifications

The automotive-grade Cyclone V devices have the same absolute maximum ratings, recommended operating conditions, and DC electrical characteristics as those published for the Cyclone V devices in the *Cyclone V Device Datasheet*.

The on-chip series termination (R_S OCT) specifications of the automotive-grade Cyclone V devices are the same as those of their corresponding industrial-grade Cyclone V devices. The switching characteristics of the automotive-grade devices are the same as those of the Cyclone V devices with -8 speed grade published in the *Cyclone V Device Datasheet*.



For the timing specifications of the automotive-grade Cyclone V devices, refer to the *Cyclone V Device Datasheet*.

The automotive-grade devices meet these timing specifications over the automotive temperature range ($T_j = -40^\circ\text{C}$ to 125°C).

Table 3-5 lists the automotive-grade ordering codes and their equivalent timing specifications for Cyclone V devices.

Table 3-5. Automotive-Grade Ordering Codes and Their Equivalent Timing Specifications for Cyclone V Devices

Automotive-Grade Device Ordering Code	Device Timing Specification		
	Device	Junction Temperature Range	Speed Grade
5CEBA2F17A7N	5CEBA2	-40°C to 125°C	-7
5CEBA4F17A7N	5CEBA4	-40°C to 125°C	-7
5CEFA2U19A7N	5CEFA2	-40°C to 125°C	-7
5CEFA4U19A7N	5CEFA4	-40°C to 125°C	-7
5CEFA5U19A7N	5CEFA5	-40°C to 125°C	-7
5CEFA7U19A7N	5CEFA7	-40°C to 125°C	-7
5CEFA9U19A7N	5CEFA9	-40°C to 125°C	-7
5CGXFC3B6U15A7N	5CGXFC3	-40°C to 125°C	-7
5CGXFC3B6U19A7N	5CGXFC3	-40°C to 125°C	-7
5CGXFC4C6U19A7N	5CGXFC4	-40°C to 125°C	-7
5CGXFC5C6U19A7N	5CGXFC5	-40°C to 125°C	-7
5CGXFC7C6U19A7N	5CGXFC7	-40°C to 125°C	-7
5CGXFC9A6U19A7N	5CGXFC9	-40°C to 125°C	-7
5CGTFD5C5U19A7N	5CGTFD5	-40°C to 125°C	-7
5CGTFD7C5U19A7N	5CGTFD7	-40°C to 125°C	-7
5CGTFD9A5U19A7N	5CGTFD9	-40°C to 125°C	-7

Note to Table 3-5:

- (1) Other automotive-grade product line/package combinations or ordering codes might be available upon request. Consult your Altera sales representative to submit your request.

Pin-Out Information

- For more information about the Cyclone V device pin-outs, refer to the [Cyclone V Device Pin-Out Files](#) page.

Package and Board Layout Information

- For package-related information (for example, dimensions and thermal resistance values) on Cyclone V devices, refer to the [Package Information Datasheet for Altera Devices](#).
- For PCB design guidelines, refer to [AN114: Designing With High-Density BGA Packages for Altera Devices](#).
- If you are designing PCBs with the Cadence OrCAD capture component information system, you can download the symbol libraries from the [Cadence Capture CIS and Allegro PCB Symbols and Footprints](#) page.

Document Revision History

Table 3-6 lists the revision history for this chapter.

Table 3-6. Document Revision History

Date	Version	Changes
September 2013	3.4	<ul style="list-style-type: none">■ Updated Table 3-2, Table 3-3, and Table 3-4.■ Updated Figure 3-1, Figure 3-2, and Figure 3-3.
June 2013	3.3	Updated Table 3-1 and Table 3-5.
May 2013	3.2	<ul style="list-style-type: none">■ Updated Figure 3-2 and Figure 3-3.■ Updated Table 3-1 and Table 3-5.
February 2013	3.1	Updated Table 3-2, Table 3-3, and Table 3-4.
January 2013	3.0	Initial release.

Supported Automotive-Grade Devices

Altera offers Cyclone® IV devices in the automotive temperature range. These devices are available only in the –7 speed grade.

Table 4–1 lists the automotive-grade devices in the Cyclone IV device family.

Table 4–1. Automotive-Grade in Cyclone IV Devices

Device Ordering Code	Package
EP4CE6E22A7N	144-Pin EQFP
EP4CE10E22A7N	144-Pin EQFP
EP4CE22E22A7N	144-Pin EQFP
EP4CE6F17A7N	256-Pin FBGA
EP4CE10F17A7N	256-Pin FBGA
EP4CE15F17A7N	256-Pin FBGA
EP4CE22F17A7N	256-Pin FBGA
EP4CE30F19A7N	324-Pin FBGA
EP4CE40F19A7N	324-Pin FBGA
EP4CE15F23A7N	484-Pin FBGA
EP4CE30F23A7N	484-Pin FBGA
EP4CE40F23A7N	484-Pin FBGA

Note to Table 4–1:

- (1) Other automotive-grade product line/package combinations or ordering codes might be available upon request. Consult your Altera sales representative to submit your request.

Table 4–2 and Table 4–3 show the package options and maximum user I/Os in the Cyclone IV devices.

Table 4–2. Package Options and Maximum User I/Os in Cyclone IV E Devices (Part 1 of 2)

Package Type/ Pin Count	Ball Spacing (mm)	Dimensions (mm)	Product Line								
			EP4CE6 (6.3K LEs)	EP4CE10 (10.3K LEs)	EP4CE15 (15.4K LEs)	EP4CE22 (22.3K LEs)	EP4CE30 (28.8K LEs)	EP4CE40 (39.6K LEs)	EP4CE55 (55.9K LEs)	EP4CE75 (75.4K LEs)	EP4CE115 (114.5K LEs)
			I/Os								
EQFP-144	0.5	22 x 22	91 ⁽¹⁾	91 ⁽¹⁾	81 ⁽²⁾	79 ⁽¹⁾	—	—	—	—	—
MBGA-164	0.5	8 x 8	—	—	89 ⁽²⁾	—	—	—	—	—	—
UBGA-256	0.8	14 x 14	179 ⁽²⁾	179 ⁽²⁾	165 ⁽²⁾	153 ⁽²⁾	—	—	—	—	—
FBGA-256	1.0	17 x 17	179 ⁽¹⁾	179 ⁽¹⁾	165 ⁽¹⁾	153 ⁽¹⁾	—	—	—	—	—

Table 4-2. Package Options and Maximum User I/Os in Cyclone IV E Devices (Part 2 of 2)

Package Type/ Pin Count	Ball Spacing (mm)	Dimensions (mm)	Product Line								
			EP4CE6 (6.3K LEs)	EP4CE10 (10.3K LEs)	EP4CE15 (15.4K LEs)	EP4CE22 (22.3K LEs)	EP4CE30 (28.8K LEs)	EP4CE40 (39.6K LEs)	EP4CE55 (55.9K LEs)	EP4CE75 (75.4K LEs)	EP4CE115 (114.5K LEs)
			I/Os								
UBGA-484	0.8	19 x 19	—	—	—	—	—	328 ⁽²⁾	324 ⁽²⁾	292 ⁽²⁾	—
FBGA-324	1.0	19 x 19	—	—	—	—	193 ⁽¹⁾	193 ⁽¹⁾	—	—	—
FBGA-484	1.0	23 x 23	—	—	343 ⁽¹⁾	—	328 ⁽¹⁾	328 ⁽¹⁾	324 ⁽²⁾	292 ⁽²⁾	280 ⁽²⁾
FBGA-780	1.0	29 x 29	—	—	—	—	532 ⁽²⁾	532 ⁽²⁾	374 ⁽²⁾	426 ⁽²⁾	528 ⁽²⁾

Notes to Table 4-2:

- (1) Package options available with automotive-grade variants.
- (2) These package options are not currently available in automotive-grade but might become available upon request. Consult your Altera sales representative to submit your request.

Table 4-3. Package Options and Maximum User I/Os in Cyclone IV GX Devices

Package Type/ Pin Count	Ball Spacing (mm)	Dimensions (mm)	Product Line						
			EP4CGX15 (14.4K LEs)	EP4CGX22 (21.3K LEs)	EP4CGX30 (29.4K LEs)	EP4CGX50 (49.9K LEs)	EP4CGX75 (73.9K LEs)	EP4CGX110 (109.4K LEs)	EP4CGX150 (149.8K LEs)
			I/Os						
QFN-148	0.5	11 x 11	72 / 2 ⁽²⁾	—	—	—	—	—	—
FBGA-169	1.0	14 x 14	72 / 2 ⁽¹⁾	72 / 2 ⁽²⁾	72 / 2 ⁽²⁾	—	—	—	—
FBGA-324	1.0	19 x 19	—	150 / 4 ⁽²⁾	150 / 4 ⁽²⁾	—	—	—	—
FBGA-484	1.0	23 x 23	—	—	290 / 4 ⁽²⁾	290 / 4 ⁽²⁾	290 / 4 ⁽²⁾	270 / 4 ⁽²⁾	270 / 4 ⁽²⁾
FBGA-672	1.0	27 x 27	—	—	—	310 / 8 ⁽²⁾	310 / 8 ⁽²⁾	393 / 8 ⁽²⁾	393 / 8 ⁽²⁾
FBGA-896	1.0	31 x 31	—	—	—	—	—	475 / 8 ⁽²⁾	475 / 8 ⁽²⁾

Notes to Table 4-3:

- (1) Package options available with automotive-grade variants.
- (2) These package options are not currently available in automotive-grade but might become available upon request. Consult your Altera sales representative to submit your request.

This chapter contains the following sections:

- “Device Ordering Codes” on page 4-3
- “Quartus II Software Support” on page 4-3
- “Power Analysis and Estimation” on page 4-4
- “DC and Timing Specifications” on page 4-5
- “Pin-Out Information” on page 4-6
- “Package and Board Layout Information” on page 4-6

Device Ordering Codes

Figure 4-1 shows the ordering codes for automotive-grade devices offered in the Cyclone IV device family.



 For more information about a specific package, refer to the *Package Information Datasheet for Altera Devices*.

Figure 4-1. Automotive-Grade Ordering Information for Cyclone IV Devices

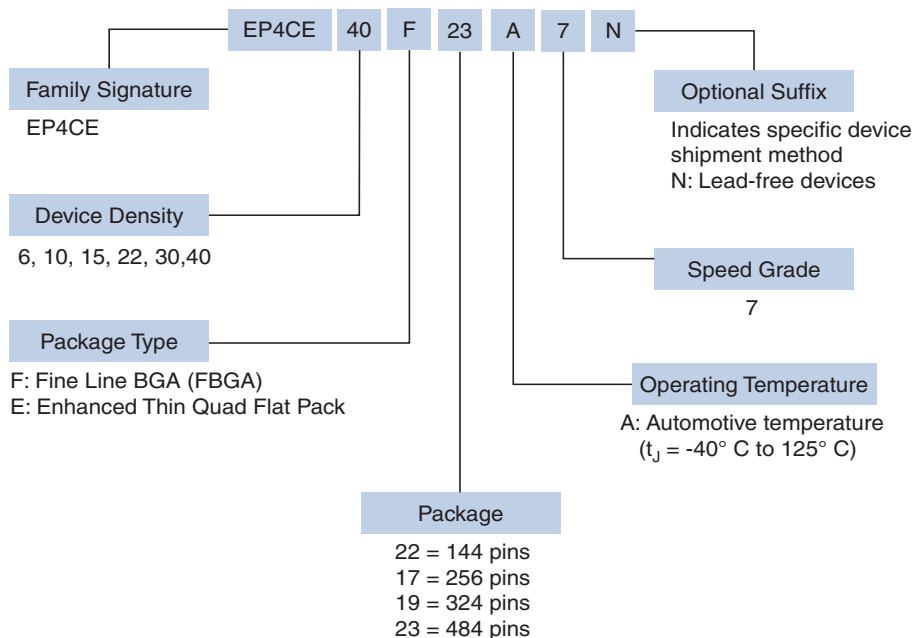

Quartus II Software Support

The Altera® Quartus® II design software supports the Cyclone IV devices in the automotive temperature range. The Quartus II software provides a comprehensive environment for system on a chip (SoC) design. It also includes HDL and schematic design entry, compilation and logic synthesis, full simulation and advanced timing analysis, SignalTap™ II logic analyzer, and device configuration.

 For more information about the Quartus II software features, refer to the *Quartus II Handbook*.

To target an automotive-grade Cyclone IV device in your design in the Quartus II software, follow these steps:

1. On the Assignments menu, click **Device**. The **Settings** dialog box appears.
2. In the **Family** drop-down list, select **Cyclone IV**.
3. Under Target device, select **Specific device selected in 'Available devices' list**.
4. In the **Available devices** list, select the appropriate ordering code, as listed in [Table 4-1](#).

 The Quartus II software does not show the “N” suffix, which indicates a lead-free device. For example, the EP4CE6F17A7N device is shown only as EP4CE6F17A7.

5. Click **OK**.

 Support for the automotive-grade Cyclone IV devices is only available in the Quartus II software version 9.1 SP2 and later.

Power Analysis and Estimation

Altera provides the following power analysis and estimation tools for your design:

- “PowerPlay Early Power Estimator”
- “PowerPlay Power Analyzer”

PowerPlay Early Power Estimator

The PowerPlay Early Power Estimator (EPE) is a power estimation tool that helps you estimate the power consumption of your design during the system planning phase for proper power supply planning and consideration. The EPE allows you to enter design information based on architectural features and calculates the power consumed by each architectural feature. Inputs to the EPE are environmental conditions and device resources (such as clock frequency, RAM blocks, and digital signal processing [DSP] blocks) that you expect to use in your design. The EPE then calculates the static and dynamic power, current estimates, and thermal analysis for the design.

You can either enter the design information manually into the spreadsheet or import a power estimator file of a fully or partially completed design from the Quartus II software. After importing a file, you can edit some of the input parameters including V_{CCINT} , ambient temperature, airflow, clock frequency, and toggle percentage to suit your system requirements.

 The value obtained from the EPE is only an estimation and should not be used as a specification. The accuracy of the EPE results depends on how close your input of the design information into the EPE resembles that of the final design.

 For more information about the EPE, and how to generate and import the power estimator file, refer to the *PowerPlay Early Power Estimator User Guide*.

PowerPlay Power Analyzer

The PowerPlay Power Analyzer tool in the Quartus II software is a power analysis tool that helps you calculate your design power consumption accurately to ensure thermal and power supply budgets are not violated after your design is complete. The PowerPlay Power Analyzer tool requires your design to be synthesized and fitted to the target device. Availability of information such as design resources, how the design is placed and routed on the target device, and the I/O standards assigned to each I/O cell allow the PowerPlay Power Analyzer tool to provide accurate power estimation.

The process of using the PowerPlay Power Analyzer tool consists of three parts—specifying sources of input data, specifying operating conditions, and running the PowerPlay Power Analyzer tool.

The input data consists of the signal activities data (toggle rates and static probabilities) of the compiled design. Signal activity data can be derived from simulation results, user assignment in the Assignment Editor, user-defined default toggle rate, and vectorless estimation.

The operating conditions include device power characteristic, ambient and junction temperature, cooling solution, and board thermal model, all of which can be set in the Quartus II software.

The PowerPlay Power Analyzer tool calculates the dynamic, static and I/O thermal power consumption, current consumed from voltage source, a summary of the signal activities used for analysis, and a confidence metric that reflects the overall quality of the data sources for the signal activities.



For more information about the PowerPlay Power Analyzer tool, refer to the *PowerPlay Power Analysis* chapter in volume 3 of the *Quartus II Handbook*.

DC and Timing Specifications

The automotive-grade Cyclone IV devices have the same absolute maximum ratings, recommended operating conditions, and DC electrical characteristics as those published for the Cyclone IV devices in the *Cyclone IV Device Datasheet* chapter in volume 3 of the *Cyclone IV Device Handbook*.

The on-chip series termination (R_S OCT) specifications of the automotive-grade Cyclone IV devices are the same as those of their corresponding industrial-grade Cyclone IV devices. The switching characteristics of the automotive-grade devices are the same as those of the Cyclone IV devices with -8 speed grade published in the *Cyclone IV Device Datasheet* chapter in volume 3 of the *Cyclone IV Device Handbook*.



For the timing specifications of the automotive-grade Cyclone IV devices, refer to the *Cyclone IV Device Datasheet* chapter in the volume 3 of the *Cyclone IV Device Handbook*.

The automotive-grade devices meet these timing specifications over the automotive temperature range ($T_j = -40^\circ\text{C}$ to 125°C).

Table 4-4 lists the automotive-grade ordering codes and their equivalent timing specifications for Cyclone IV devices.

Table 4-4. Automotive-Grade Ordering Codes and Their Equivalent Timing Specifications for Cyclone IV Devices

Automotive-Grade Device Ordering Code	Device Timing Specification		
	Device	Junction Temperature Range	Speed Grade
EP4CE6F17A7N	EP4CE6	-40°C to 125°C	-7
EP4CE6E22A7N	EP4CE6	-40°C to 125°C	-7
EP4CE10F17A7N	EP4CE10	-40°C to 125°C	-7
EP4CE10E22A7N	EP4CE10	-40°C to 125°C	-7
EP4CE15F17A7N	EP4CE15	-40°C to 125°C	-7
EP4CE15F23A7N	EP4CE15	-40°C to 125°C	-7
EP4CE22F17A7N	EP4CE22	-40°C to 125°C	-7
EP4CE22E22A7N	EP4CE22	-40°C to 125°C	-7
EP4CE30F19A7N	EP4CE30	-40°C to 125°C	-7
EP4CE30F23A7N	EP4CE30	-40°C to 125°C	-7
EP4CE40F19A7N	EP4CE40	-40°C to 125°C	-7
EP4CE40F23A7N	EP4CE40	-40°C to 125°C	-7

Note to Table 4-4:

- (1) Other automotive-grade product line/package combinations or ordering codes might be available upon request. Consult your Altera sales representative to submit your request.

Pin-Out Information

- For more information about the Cyclone IV device pin-outs, refer to the [Cyclone IV Device Pin-Out Files](#) page.

Package and Board Layout Information

- For package-related information (for example, dimensions and thermal resistance values) on Cyclone IV devices, refer to the [Package Information Datasheet for Altera Devices](#).
- For PCB design guidelines, refer to [AN114: Designing With High-Density BGA Packages for Altera Devices](#).
- If you are designing PCBs with the Cadence OrCAD capture component information system, you can download the symbol libraries from the [Cadence Capture CIS and Allegro PCB Symbols and Footprints](#) page.

Document Revision History

Table 4-5 lists the revision history for this chapter.

Table 4-5. Document Revision History

Date	Version	Changes
September 2013	3.4	No update.
June 2013	3.3	No update.
May 2013	3.2	<ul style="list-style-type: none">■ Updated Table 4-2.■ Updated Figure 4-1.
February 2013	3.1	Updated Table 4-2 and Table 4-3.
January 2013	3.0	<ul style="list-style-type: none">■ Added Table 4-2 and Table 4-3.■ Updated Table 4-1 and Table 4-4.■ Updated Figure 4-1.
May 2011	2.0	<ul style="list-style-type: none">■ Updated part number from AUT51006 to AUT51008.■ Template conversion.■ Minor text edits.
March 2010	1.2	Initial release.

Supported Automotive-Grade Devices

Altera offers MAX[®] V devices in the automotive temperature range. These devices are available only in the –5 speed grade.

Table 5–1 lists the automotive-grade devices in the MAX V device family.

Table 5–1. Automotive-Grade in MAX V Devices

Device Ordering Code	Package
5M80ZE64A5N	64-Pin EQFP
5M160ZE64A5N	64-Pin EQFP
5M240ZT100A5N	100-Pin TQFP
5M570ZT100A5N	100-Pin TQFP
5M1270ZF256A5N	256-Pin FBGA
5M1270ZT144A5N	144-Pin TQFP

Note to Table 5–1:

- (1) Other automotive-grade product line/package combinations or ordering codes might be available upon request. Consult your Altera sales representative to submit your request.

Table 5–2 shows the package options and maximum user I/Os in the MAX V devices.

Table 5–2. Package Options and Maximum User I/Os in MAX V Devices

Package Type/ Pin Count	Ball Spacing (mm)	Dimensions (mm)	Product Line						
			5M40Z (40K LEs)	5M80Z (80K LEs)	5M160Z (160K LEs)	5M240Z (240K LEs)	5M570Z (570K LEs)	5M1270Z (1270K LEs)	5M2210Z (2210K LEs)
			I/Os						
MBGA-64	0.5	4.5 x 4.5	30 ⁽²⁾	30 ⁽²⁾	—	—	—	—	—
EQFP-64	0.5	7 x 7	54 ⁽²⁾	54 ⁽¹⁾	54 ⁽¹⁾	—	—	—	—
MBGA-68	0.5	5 x 5	—	52 ⁽²⁾	52 ⁽²⁾	52 ⁽²⁾	—	—	—
QFP-100	0.5	14 x 14	—	79 ⁽¹⁾	79 ⁽²⁾	79 ⁽¹⁾	74 ⁽¹⁾	—	—
MBGA-100	0.5	6 x 6	—	—	79 ⁽²⁾	79 ⁽²⁾	74 ⁽²⁾	—	—
DFP-144	0.5	20 x 20	—	—	—	114 ⁽²⁾	114 ⁽²⁾	114 ⁽¹⁾	—
FBGA-256	1.0	17 x 17	—	—	—	—	159 ⁽²⁾	211 ⁽¹⁾	203 ⁽²⁾
FBGA-324	1.0	19 x 19	—	—	—	—	—	271 ⁽²⁾	271 ⁽²⁾

Notes to Table 5–2:

- (1) Package options available with automotive-grade variants.
 (2) These package options are not currently available in automotive-grade but might become available upon request. Consult your Altera sales representative to submit your request.

This chapter contains the following sections:

- “Device Ordering Codes” on page 5-2
- “Quartus II Software Support” on page 5-3
- “Power Analysis and Estimation” on page 5-3
- “DC and Timing Specifications” on page 5-4
- “Pin-Out Information” on page 5-5
- “Package and Board Layout Information” on page 5-5

Device Ordering Codes

Figure 5-1 shows the ordering codes for automotive-grade devices offered in the MAX V device family.

 For more information about a specific package, refer to the *Package Information Datasheet for Altera Devices*.

Figure 5-1. Automotive-Grade Ordering Information for MAX V Devices

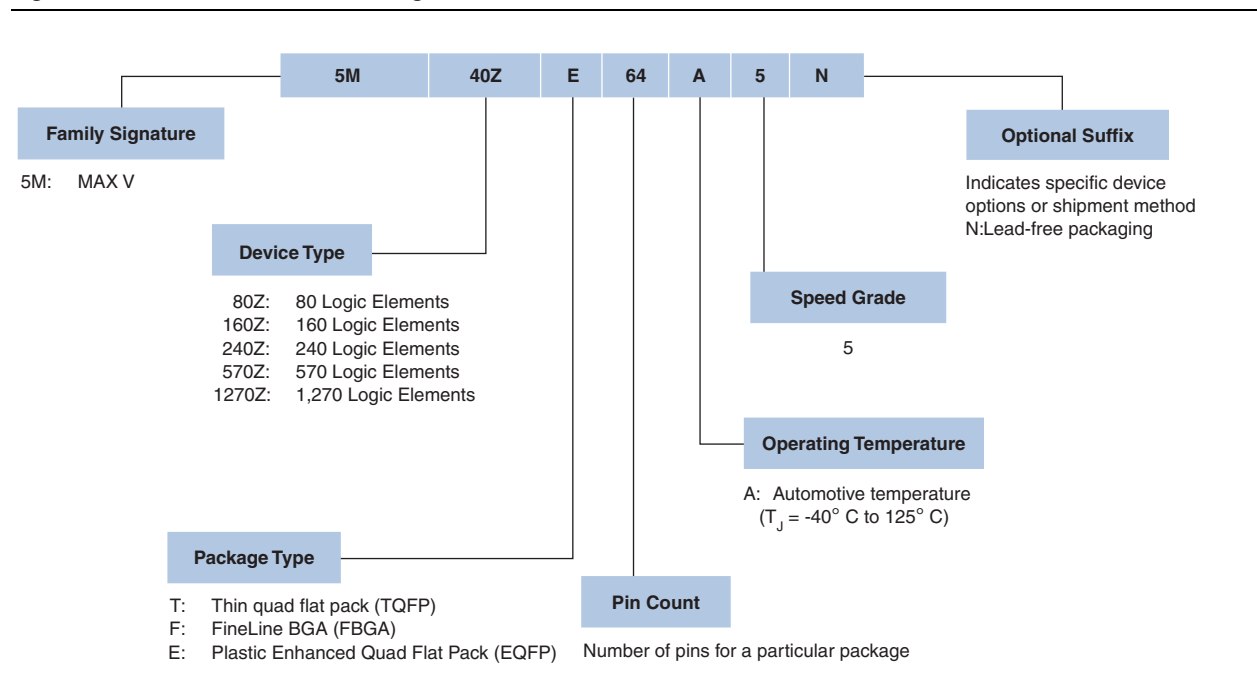

Quartus II Software Support

The Altera® Quartus® II design software supports the MAX V devices in the automotive temperature range. The Quartus II software includes HDL and schematic design entry, compilation and logic synthesis, full simulation and advanced timing analysis, and device programming.



For more information about the Quartus II software features, refer to the *Quartus II Handbook*.

To target an automotive-grade MAX V device in your design in the Quartus II software, follow these steps:

1. On the Assignments menu, click **Device**. The **Settings** dialog box appears.
2. In the **Family** drop-down list, select **MAX V**.
3. Under Target device, select **Specific device selected in 'Available devices' list**.
4. In the **Available devices** list, select the appropriate ordering code, as listed in [Table 5-1](#).



The Quartus II software does not show the “N” suffix, which indicates a lead-free device. For example, the device 5M80ZE64A5N is shown only as 5M80ZE64A5.

5. Click **OK**.



Support for the automotive-grade MAX V devices is only available in the Quartus II software version 11.0 and later.

Power Analysis and Estimation



Altera provides the following power analysis and estimation tools for your design:

- “PowerPlay Early Power Estimator”
- “PowerPlay Power Analyzer”

PowerPlay Early Power Estimator

The PowerPlay Early Power Estimator (EPE) is a power estimation tool that helps you estimate the power consumption of your design during the system planning phase for proper power supply planning and consideration. The EPE allows you to enter design information based on architectural features and calculates the power consumed by each architectural feature. Inputs to the EPE are environmental conditions and device resources (such as clock frequency) that you expect to use in your design. The EPE then calculates the static and dynamic power, current estimates, and thermal analysis for your design.

You can either enter the design information manually into the spreadsheet or import a power estimator file of a fully or partially completed design from the Quartus II software. After importing a file, you can edit some of the input parameters including V_{CCINT} , ambient temperature, airflow, clock frequency, and toggle percentage to suit your system requirements.

-  The value obtained from the EPE is only an estimation and should not be used as a specification. The accuracy of the EPE results depends on how close your input of the design information into the EPE resembles that of the final design.
-  For more information about the EPE, and how to generate and import the power estimator file, refer to the *PowerPlay Early Power Estimator for Altera CPLDs User Guide*.

PowerPlay Power Analyzer

The PowerPlay Power Analyzer tool in the Quartus II software is a power analysis tool that helps you calculate your design power consumption accurately to ensure thermal and power supply budgets are not violated after your design is complete. The PowerPlay Power Analyzer tool requires your design to be synthesized and fitted to the target device. Availability of information such as design resources, how the design is placed and routed on the target device, and the I/O standards assigned to each I/O cell allow the PowerPlay Power Analyzer tool to provide accurate power estimation.

The process of using the PowerPlay Power Analyzer tool consists of three parts—specifying sources of input data, specifying operating conditions, and running the PowerPlay Power Analyzer tool.

The input data consists of the signal activities data (toggle rates and static probabilities) of the compiled design. Signal activity data can be derived from simulation results, user assignment in the Assignment Editor, user-defined default toggle rate, and vectorless estimation.

The operating conditions include device power characteristic, ambient and junction temperature, cooling solution, and board thermal model, all of which can be set in the Quartus II software.

The PowerPlay Power Analyzer tool calculates the dynamic, static and I/O thermal power consumption, current consumed from voltage source, a summary of the signal activities used for analysis, and a confidence metric that reflects the overall quality of the data sources for the signal activities.

-  For more information about the PowerPlay Power Analyzer tool, refer to the *PowerPlay Power Analysis* chapter in volume 3 of the *Quartus II Handbook*.

DC and Timing Specifications

The automotive-grade MAX V devices have the same absolute maximum ratings, recommended operating conditions, and DC electrical characteristics as those published for the MAX V devices in the *DC and Switching Characteristics for MAX V Devices* chapter of the *MAX V Device Handbook*.

The timing specifications of the automotive-grade MAX V devices are the same as those published for the MAX V devices in the *DC and Switching Characteristics for MAX V Devices* chapter of the *MAX V Device Handbook*. The automotive-grade devices meet these timing specifications over the automotive temperature range ($T_j = -40^{\circ}\text{C}$ to 125°C).

Table 5-3 lists the automotive-grade ordering codes and their equivalent timing specifications for MAX V devices.

Table 5-3. Automotive-Grade Ordering Codes and Their Equivalent Timing Specifications for MAX V Devices

Automotive-Grade Device Ordering Code	Device Timing Specification		
	Device	Junction Temperature Range	Speed Grade
5M80ZE64A5N	5M80Z	-40°C to 125°C	-5
5M160ZE64A5N	5M160Z	-40°C to 125°C	-5
5M240ZT100A5N	5M240Z	-40°C to 125°C	-5
5M570ZT100A5N	5M570Z	-40°C to 125°C	-5
5M1270ZF256A5N	5M1270Z	-40°C to 125°C	-5
5M1270ZT144A5N	5M1270Z	-40°C to 125°C	-5

Pin-Out Information

- For more information about the MAX V device pin-outs, refer to the [MAX V Device Pin-Out Files](#) page.

Package and Board Layout Information

- For package-related information (for example, dimensions and thermal resistance values) about MAX V devices, refer to the [Package Information Datasheet for Altera Devices](#).
- For PCB design guidelines, refer to [AN114: Designing With High-Density BGA Packages for Altera Devices](#).
- If you are designing PCBs with the Cadence OrCAD capture component information system, you can download the symbol libraries from the [Cadence Capture CIS and Allegro PCB Symbols and Footprints](#) page.

Document Revision History

Table 5-4 lists the revision history for this chapter.

Table 5-4. Document Revision History

Date	Version	Changes
September 2013	3.4	No update.
June 2013	3.3	No update.
May 2013	3.2	<ul style="list-style-type: none"> Updated Table 5-1 and Table 5-3. Updated Figure 5-1.
February 2013	3.1	Updated Table 5-2.
January 2013	3.0	Added Table 5-2.
May 2011	2.0	Initial release.

Supported Automotive-Grade Devices

Altera offers MAX[®] II devices in the automotive temperature range. These devices are available only in the –5 speed grade.

Table 6–1 lists the automotive-grade devices in the MAX II device family.

Table 6–1. Automotive-Grade MAX II Devices

Device Ordering Code	Package
EPM240T100A5N	100-Pin TQFP
EPM570F100A5N	100-Pin FineLine BGA
EPM570T100A5N	100-Pin TQFP
EPM570T144A5N	144-Pin TQFP
EPM1270T144A5N	144-Pin TQFP
EPM1270F256A5N	256-Pin FineLine BGA
EPM2210F256A5N	256-Pin FineLine BGA
EPM2210F324A5N	324-Pin FineLine BGA

Note to Table 6–1:

- (1) Other automotive-grade product line/package combinations or ordering codes might be available upon request. Consult your Altera sales representative to submit your request.

This chapter contains the following sections:

- “Device Ordering Codes” on page 6–2
- “Quartus II Software Support” on page 6–2
- “Power Analysis and Estimation” on page 6–3
- “DC and Timing Specifications” on page 6–4
- “Pin-Out Information” on page 6–5
- “Package and Board Layout Information” on page 6–5

Device Ordering Codes

Figure 6-1 shows the ordering codes for automotive-grade devices offered in the MAX II device family.

For more information about a specific package, refer to the [Package Information Datasheet for Altera Devices](#).

Figure 6-1. Automotive-Grade Ordering Information for MAX II Devices

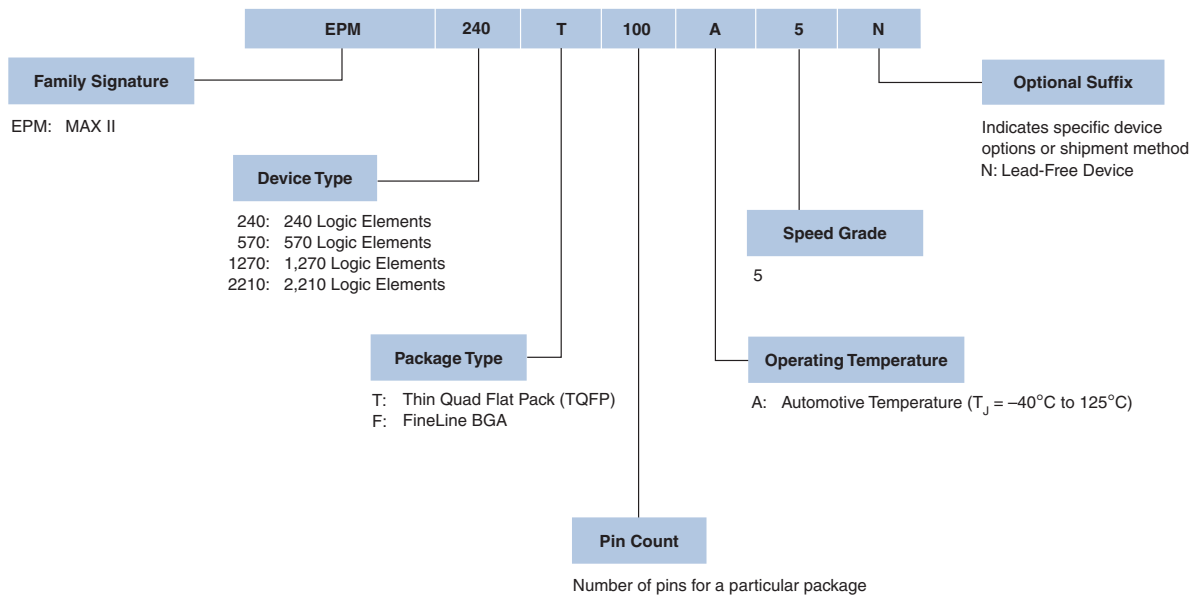

Quartus II Software Support

The Altera® Quartus® II design software supports the MAX II devices in the automotive temperature range. The Quartus II software includes HDL and schematic design entry, compilation and logic synthesis, full simulation and advanced timing analysis, and device programming.

For more information about the Quartus II software features, refer to the [Quartus II Handbook](#).

To target an automotive-grade MAX II device in your design in the Quartus II software, follow these steps:

1. On the Assignments menu, click **Device**. The **Settings** dialog box appears.
2. In the **Family** drop-down list, select **MAX II**.
3. Under Target device, select **Specific device selected in 'Available devices' list**.
4. In the **Available devices** list, select the appropriate ordering code, as listed in [Table 6-1](#).



The Quartus II software does not show the “N” suffix, which indicates a lead-free device. For example, the device EPM240T100A5N is shown only as EPM240T100A5.

5. Click **OK**.



Support for the automotive-grade MAX II devices is only available in the Quartus II software version 7.2 SP1 and later.

Power Analysis and Estimation

Altera provides the following power analysis and estimation tools for your design:

- “PowerPlay Early Power Estimator”
- “PowerPlay Power Analyzer”

PowerPlay Early Power Estimator

The PowerPlay Early Power Estimator (EPE) is a power estimation tool that helps you estimate the power consumption of your design during the system planning phase for proper power supply planning and consideration. The EPE allows you to enter design information based on architectural features and calculates the power consumed by each architectural feature. Inputs to the EPE are environmental conditions and device resources (such as clock frequency) that you expect to use in your design. The EPE then calculates the static and dynamic power, current estimates, and thermal analysis for your design.

You can either enter the design information manually into the spreadsheet or import a power estimator file of a fully or partially completed design from the Quartus II software. After importing a file, you can edit some of the input parameters including V_{CCINT} , ambient temperature, airflow, clock frequency, and toggle percentage to suit your system requirements.



The value obtained from the EPE is only an estimation and should not be used as a specification. The accuracy of the EPE results depends on how close your input of the design information into the EPE resembles that of the final design.



For more information about the EPE, and how to generate and import the power estimator file, refer to the *PowerPlay Early Power Estimator for Altera CPLDs User Guide*.

PowerPlay Power Analyzer

The PowerPlay Power Analyzer tool in the Quartus II software is a power analysis tool that helps you calculate your design power consumption accurately to ensure thermal and power supply budgets are not violated after your design is complete. The PowerPlay Power Analyzer tool requires your design to be synthesized and fitted to the target device. Availability of information such as design resources, how the design is placed and routed on the target device, and the I/O standards assigned to each I/O cell allow the PowerPlay Power Analyzer tool to provide accurate power estimation.

The process of using the PowerPlay Power Analyzer tool consists of three parts—specifying sources of input data, specifying operating conditions, and running the PowerPlay Power Analyzer tool.

The input data consists of the signal activities data (toggle rates and static probabilities) of the compiled design. Signal activity data can be derived from simulation results, user assignment in the Assignment Editor, user-defined default toggle rate, and vectorless estimation.

The operating conditions include device power characteristic, ambient and junction temperature, cooling solution, and board thermal model, all of which can be set in the Quartus II software.

The PowerPlay Power Analyzer tool calculates the dynamic, static and I/O thermal power consumption, current consumed from voltage source, a summary of the signal activities used for analysis, and a confidence metric that reflects the overall quality of the data sources for the signal activities.

 For more information about the PowerPlay Power Analyzer tool, refer to the *PowerPlay Power Analysis* chapter in volume 3 of the *Quartus II Handbook*.

DC and Timing Specifications

Automotive-grade MAX II devices have the same absolute maximum ratings, recommended operating conditions, and DC electrical characteristics as those published for the MAX II devices in the *DC and Switching Characteristics* chapter of the *MAX II Device Handbook*.

The timing specifications of the automotive-grade MAX II devices are the same as those published for the MAX II devices in the *DC and Switching Characteristics* chapter of the *MAX II Device Handbook*. The automotive-grade devices meet these timing specifications over the automotive temperature range ($T_j = -40^\circ\text{C}$ to 125°C).

Table 6–2 lists the automotive-grade ordering codes and their equivalent timing specifications for MAX II devices.

Table 6–2. Automotive-Grade Ordering Codes and Their Equivalent Timing Specifications for MAX II Devices (Part 1 of 2)

Automotive-Grade Device Ordering Code	Device Timing Specification		
	Device	Junction Temperature Range	Speed Grade
EPM240T100A5N	EPM240	-40°C to 125°C	–5
EPM570F100A5N	EPM570	-40°C to 125°C	–5
EPM570T100A5N	EPM570	-40°C to 125°C	–5
EPM570T144A5N	EPM570	-40°C to 125°C	–5
EPM1270T144A5N	EPM1270	-40°C to 125°C	–5
EPM1270F256A5N	EPM1270	-40°C to 125°C	–5
EPM2210F256A5N	EPM2210	-40°C to 125°C	–5

Table 6-2. Automotive-Grade Ordering Codes and Their Equivalent Timing Specifications for MAX II Devices (Part 2 of 2)

Automotive-Grade Device Ordering Code	Device Timing Specification		
	Device	Junction Temperature Range	Speed Grade
EPM2210F324A5N	EPM2210	-40°C to 125°C	-5

Note to Table 6-2:

(1) Other automotive-grade product line/package combinations or ordering codes might be available upon request. Consult your Altera sales representative to submit your request.

Pin-Out Information

 For more information about the MAX II device pin-outs, refer to the [MAX II Device Pin-Out Files](#) page.

Package and Board Layout Information

 For package-related information (for example, dimensions and thermal resistance values) on MAX II devices, refer to the [Package Information Datasheet for Altera Devices](#).

 For PCB design guidelines, refer to [AN114: Designing With High-Density BGA Packages for Altera Devices](#).

 If you are designing PCBs with the Cadence OrCAD capture component information system, you can download the symbol libraries from the [Cadence Capture CIS and Allegro PCB Symbols and Footprints](#) page.

Document Revision History

Table 6-3 lists the revision history for this chapter.

Table 6-3. Document Revision History

Date	Version	Changes
September 2013	3.4	No update.
June 2013	3.3	No update.
May 2013	3.2	No update.
February 2013	3.1	No update.
January 2013	3.0	Updated Table 6-1 and Table 6-2.
May 2011	2.0	<ul style="list-style-type: none"> ■ Template conversion. ■ Minor text edits.
March 2010	1.2	Removed Referenced Documents section.
October 2008	1.1	Converted to new template.
February 2008	1.0	Initial release.

Supported Automotive-Grade Devices

Altera offers HardCopy® II devices in the automotive temperature range.

Table 7–1 lists the automotive-grade devices in the HardCopy II device family.

Table 7–1. Automotive-Grade in HardCopy II Devices

Device Ordering Code	Package
HC210WF484 ⁽¹⁾	484-Pin FineLine BGA

Note to Table 7–1:

(1) The HC210W device is in a wire bond package.

This chapter contains the following sections:

- “Device Ordering Codes” on page 7–1
- “Quartus II Software Support” on page 7–2
- “Power Analysis and Estimation” on page 7–2
- “DC and Timing Specifications” on page 7–3
- “Pin-Out Information” on page 7–4
- “Package and Board Layout Information” on page 7–5

Device Ordering Codes

Figure 7–1 shows the ordering codes for automotive-grade devices offered in the HardCopy II device family.



 For more information about a specific package, refer to the [Package Information Datasheet for Altera Devices](#).

Figure 7–1. Automotive-Grade Ordering Information for HardCopy II Devices

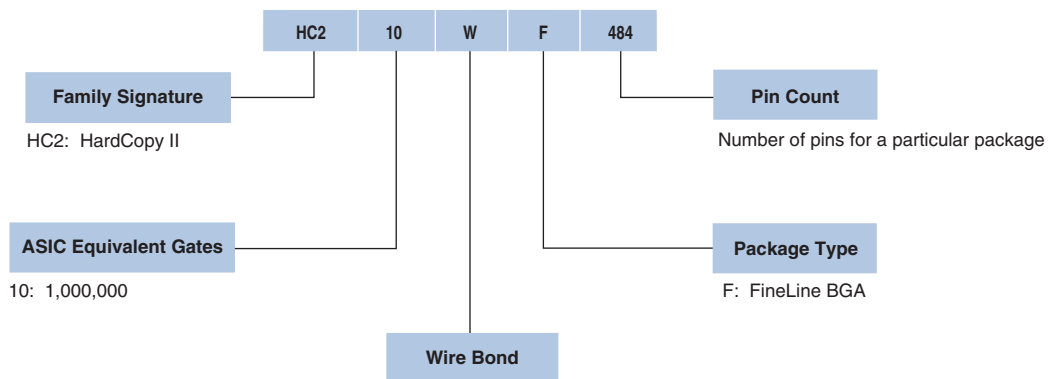

Quartus II Software Support

The Altera® Quartus® II design software supports the HardCopy II devices in the automotive temperature range. The Quartus II software provides a comprehensive environment for system on a chip (SoC) design. It also includes HDL and schematic design entry, compilation and logic synthesis, full simulation and advanced timing analysis, SignalTap™ II logic analyzer, and device configuration.

 For more information about using the Quartus II software for the HardCopy II development flow and settings, refer to the *Quartus II Support for HardCopy II Devices* chapter in volume 1 of the *HardCopy II Device Handbook*.

To target an automotive-grade HardCopy II device in your design in the Quartus II software, follow these steps:

1. On the Assignments menu, click **Device**. The **Settings** dialog box appears.
2. In the **Family** drop-down list, select **HardCopy II**.
3. Under Target device, select **Specific device selected in 'Available devices' list**.
4. In the **Available devices** list, select the appropriate ordering code, as listed in [Table 7-1](#).
5. Click **OK**.

 Support for the automotive-grade HardCopy II devices is only available in the Quartus II software version 7.2 SP1 and later.

Power Analysis and Estimation

Altera provides the following power analysis and estimation tools for your design:

- “PowerPlay Early Power Estimator”
- “PowerPlay Power Analyzer”

PowerPlay Early Power Estimator

The PowerPlay Early Power Estimator (EPE) is a power estimation tool that helps you estimate the power consumption of your design during the system planning phase for proper power supply planning and consideration. The EPE allows you to enter design information based on architectural features and calculates the power consumed by each architectural feature. Inputs to the EPE are environmental conditions and device resources (such as clock frequency) that you expect to use in your design. The EPE then calculates the static and dynamic power, current estimates, and thermal analysis for your design.

You can either enter the design information manually into the spreadsheet or import a power estimator file of a fully or partially completed design from the Quartus II software. After importing a file, you can edit some of the input parameters including V_{CCINT} , ambient temperature, airflow, clock frequency, and toggle percentage to suit your system requirements.



The value obtained from the EPE is only an estimation and should not be used as a specification. The accuracy of the EPE results depends on how close your input of the design information into the EPE resembles that of the final design.

PowerPlay Power Analyzer

The PowerPlay Power Analyzer tool in the Quartus II software is a power analysis tool that helps you calculate your design power consumption accurately to ensure thermal and power supply budgets are not violated after your design is complete. The PowerPlay Power Analyzer tool requires your design to be synthesized and fitted to the target device. Availability of information such as design resources, how the design is placed and routed on the target device, and the I/O standards assigned to each I/O cell allow the PowerPlay Power Analyzer tool to provide accurate power estimation.

The process of using the PowerPlay Power Analyzer tool consists of three parts—specifying sources of input data, specifying operating conditions, and running the PowerPlay Power Analyzer tool.

The input data consists of the signal activities data (toggle rates and static probabilities) of the compiled design. Signal activity data can be derived from simulation results, user assignment in the Assignment Editor, user-defined default toggle rate, and vectorless estimation.

The operating conditions include device power characteristic, ambient and junction temperature, cooling solution, and board thermal model, all of which can be set in the Quartus II software.

The PowerPlay Power Analyzer tool calculates the dynamic, static and I/O thermal power consumption, current consumed from voltage source, a summary of the signal activities used for analysis, and a confidence metric that reflects the overall quality of the data sources for the signal activities.



For more information about the PowerPlay Power Analyzer tool, refer to the *PowerPlay Power Analysis* chapter in volume 3 of the *Quartus II Handbook*.

DC and Timing Specifications

The automotive-grade HardCopy II devices have the same absolute maximum ratings, recommended operating conditions, and DC electrical characteristics as their equivalent industrial-grade devices. The timing specifications is equivalent to the speed grade of the prototype FPGA, except when noted as part of the HardCopy II timing specification design review process.

The operating junction temperature, T_j , for the automotive-grade HardCopy II devices is from -40°C to 125°C .

For more information about the DC characteristics of the industrial-grade HardCopy II devices, refer to the *DC and Switching Specifications and Operating Conditions* chapter in volume 1 of the *HardCopy II Device Handbook*. However, the following exceptions apply:

- The delay-locked loop (DLL) frequency range is bounded by the minimum frequencies listed in [Table 7-2](#).

[Table 7-2](#) lists the minimum DLL frequency for each frequency mode.

Table 7-2. Minimum DLL Frequency

Mode	Frequency (MHz)
Frequency Mode 0	120
Frequency Mode 1	170
Frequency Mode 2	220
Frequency Mode 3	270

- Non-calibrated on-chip termination (OCT) is bounded by:
 - $\pm 40\%$ for series resistance.
 - $\pm 50\%$ for 1.2-V series resistance.
- Hot-socketing DC limit is raised to 350 μA .
- The I/O f_{MAX} values of automotive-grade HardCopy II devices are 15% lower than their equivalent industrial-grade HardCopy II devices and correspond to the commercial-grade Stratix® II devices of -5 speed. The I/O f_{MAX} values of the industrial-grade HardCopy II devices will be updated in a later revision of the *DC and Switching Specifications and Operating Conditions* chapter in volume 1 of the *HardCopy II Device Handbook*.



For the maximum I/O clock toggle rate specifications in commercial-grade Stratix II devices of -5 speed, refer to the *DC and Switching Characteristics* chapter in volume 1 of the *Stratix II Device Handbook*.

- For LVDS I/O of 2.5 V, the minimum V_{OCM} is 1.1 V and the minimum differential output voltage (V_{OD}) is 240 mV.

Pin-Out Information

For more information about the HardCopy II device pin-outs, refer to the [HardCopy II Device Pin-Out Files](#) page.

Package and Board Layout Information

-  For package-related information (for example, dimensions and thermal resistance values) on HardCopy II devices, refer to the *Package Information Datasheet for Altera Devices*.
-  For PCB design guidelines, refer to *AN114: Designing With High-Density BGA Packages for Altera Devices*.

Document Revision History

Table 7-3 lists the revision history for this chapter.

Table 7-3. Document Revision History

Date	Version	Changes
September 2013	3.4	No update.
June 2013	3.3	No update.
May 2013	3.2	No update.
February 2013	3.1	No update.
January 2013	3.0	No update.
May 2011	2.0	<ul style="list-style-type: none">■ Template conversion.■ Minor text edits.
March 2010	1.2	Removed Referenced Documents section.
October 2008	1.1	Converted to new template.
February 2008	1.0	Initial release.

Supported Automotive-Grade Devices

Altera offers legacy support for Cyclone® III devices in the automotive temperature range. These devices are available only in the –7 speed grade.

Legacy support provides existing customers with full production and technical support, while new customers should contact the nearest Altera sales representative for possible alternatives.

Table 8–1 shows the automotive-grade devices in the Cyclone III device family.

Table 8–1. Automotive-Grade Cyclone III Devices

Device Ordering Code	Package
EP3C5E144A7N	144-Pin EQFP
EP3C5F256A7N	256-Pin FineLine BGA
EP3C5U256A7N	256-Pin UBGA
EP3C10E144A7N	144-Pin EQFP
EP3C10F256A7N	256-Pin FineLine BGA
EP3C10U256A7N	256-Pin UBGA
EP3C16E144A7N	144-Pin EQFP
EP3C16F256A7N	256-Pin FineLine BGA
EP3C16U256A7N	256-Pin UBGA
EP3C16F484A7N	484-Pin FineLine BGA
EP3C16U484A7N	484-Pin UBGA
EP3C25E144A7N	144-Pin EQFP
EP3C25F256A7N	256-Pin FineLine BGA
EP3C25U256A7N	256-Pin UBGA
EP3C25F324A7N	324-Pin FineLine BGA
EP3C40F324A7N	324-Pin FineLine BGA
EP3C40F484A7N	484-Pin FineLine BGA
EP3C40U484A7N	484-Pin UBGA

This chapter contains the following sections:

- “Device Ordering Codes” on page 8–2
- “Quartus II Software Support” on page 8–2
- “Power Analysis and Estimation” on page 8–3
- “DC and Timing Specifications” on page 8–4
- “Pin-Out Information” on page 8–5
- “Package and Board Layout Information” on page 8–5

Device Ordering Codes

Figure 8-1 describes the ordering codes for automotive-grade devices offered in the Cyclone III family.

 For more information on a specific package, refer to the *Altera Device Package Information Data Sheet*.

Figure 8-1. Automotive-Grade Ordering Information for Cyclone III Devices



Quartus II Software Support

Legacy support for Cyclone III automotive grade devices in Altera® Quartus® II design software requires special approval. Contact the nearest Altera sales representative to submit your request.

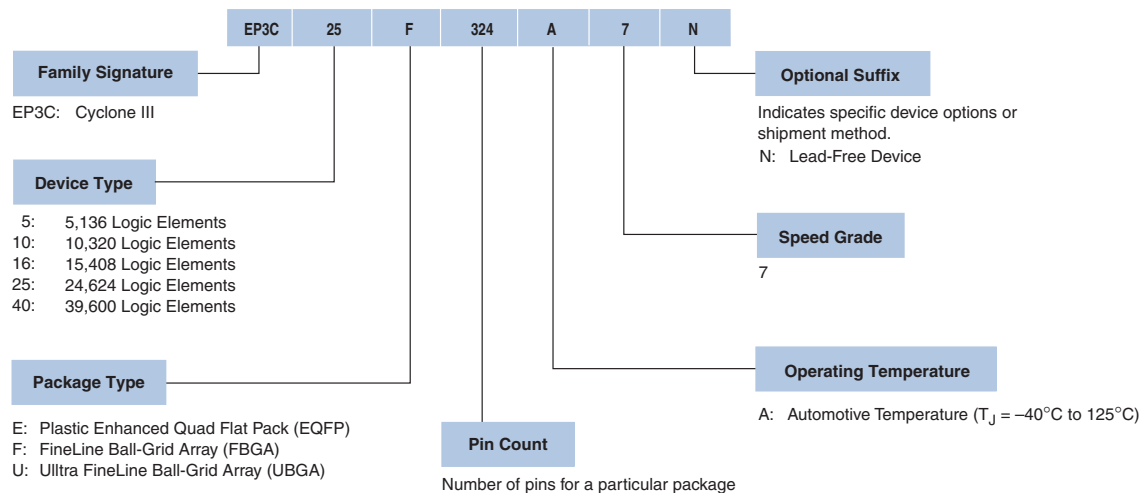
The Quartus II software provides a comprehensive environment for system-on-a-programmable-chip (SOPC) design. It also includes HDL and schematic design entry, compilation and logic synthesis, full simulation and advanced timing analysis, SignalTap™ II logic analyzer, and device configuration.

 For more information about the Quartus II software features, refer to the *Quartus II Handbook*.

To target an automotive-grade Cyclone III device in your design, perform the following steps in the Quartus II software:

1. On the Assignments menu, click **Device**. The **Settings** dialog box appears.
2. In the **Family** drop-down list, select **Cyclone III**.
3. Under Target device, select **Specific device selected in 'Available devices' list**.
4. In the **Available devices** list, select the appropriate ordering code, as shown in [Table 8-1](#).

 The Quartus II software does not show the “N” suffix, which indicates a lead-free device. For example, the EP3C10F256A7N device is shown only as EP3C10F256A7.

5. Click **OK**.

 Support for the automotive-grade Cyclone III devices is only available in the Quartus II software version 8.0 and later.

Power Analysis and Estimation

Altera provides the following power analysis and estimation tools for your design:

- “PowerPlay Early Power Estimator”
- “PowerPlay Power Analyzer”

PowerPlay Early Power Estimator

The PowerPlay Early Power Estimator (EPE) is a power estimation tool that helps you estimate the power consumption of your design during the system planning phase for proper power supply planning and consideration. The EPE allows you to enter design information based on architectural features and calculates the power consumed by each architectural feature. Inputs to the EPE are environmental conditions and device resources (such as clock frequency, RAM blocks, and DSP blocks) that you expect to use in your design. The EPE then calculates the static and dynamic power, current estimates, and thermal analysis for the design.

You can either enter the design information manually into the spreadsheet or import a power estimator file of a fully or partially completed design from the Quartus II software. After importing a file, you can edit some of the input parameters including V_{CCINT} , ambient temperature, airflow, clock frequency, and toggle percentage to suit your system requirements.

 The value obtained from the EPE is only an estimation and should not be used as a specification. The accuracy of the EPE results is dependent on how close your input of the design information into the EPE resembles that of the final design.

 For more information about the EPE, and how to generate and import the power estimator file, refer to the *PowerPlay Early Power Estimator User Guide for Cyclone III FPGAs*.

PowerPlay Power Analyzer

The PowerPlay Power Analyzer tool in the Quartus II software is a power analysis tool that helps you calculate your design power consumption accurately to ensure thermal and power supply budgets are not violated after your design is complete. The PowerPlay Power Analyzer tool requires your design to be synthesized and fitted to the target device. Availability of information such as design resources, how the design is placed and routed on the target device, and the I/O standards assigned to each I/O cell allow the PowerPlay Power Analyzer tool to provide accurate power estimation.

The process of using the PowerPlay Power Analyzer tool consists of three parts: specifying sources of input data, specifying operating conditions, and running the PowerPlay Power Analyzer tool.

The input data consists of the signal activities data (toggle rates and static probabilities) of the compiled design. Signal activity data can be derived from simulation results, user assignment in the Assignment Editor, user-defined default toggle rate, and vectorless estimation.

The operating conditions include device power characteristic, ambient and junction temperature, cooling solution, and board thermal model, all of which can be set in the Quartus II software.

The PowerPlay Power Analyzer tool calculates the dynamic, static and I/O thermal power consumption, current consumed from voltage source, a summary of the signal activities used for analysis, and a confidence metric that reflects the overall quality of the data sources for the signal activities.

 For more information about the Signal Activity Files (.saf) and how to create them, refer to the *Quartus II Simulator* chapter in volume 3 of the *Quartus II Handbook*.

 For more information about the PowerPlay Power Analyzer tool, refer to the *PowerPlay Power Analysis* chapter in volume 3 of the *Quartus II Handbook*.

DC and Timing Specifications

The automotive-grade Cyclone III devices have the same absolute maximum ratings, recommended operating conditions, and DC electrical characteristics as those published for the Cyclone III devices in the *DC and Switching Characteristics* chapter of the *Cyclone III Device Handbook*.

The on-chip series termination (R_s OCT) specifications of the automotive-grade Cyclone III devices are the same as those of their corresponding industrial-grade Cyclone III devices. The switching characteristics of the automotive-grade devices are the same as those of the Cyclone III devices with -8 speed grade published in the *DC and Switching Characteristics* chapter of the *Cyclone III Device Handbook*.

 For the timing specifications of the automotive-grade Cyclone II devices, refer to the *DC and Switching Characteristics* chapter of the *Cyclone III Device Handbook*

The automotive-grade devices meet these timing specifications over the automotive temperature range ($T_j = -40^\circ\text{C}$ to 125°C).

Table 8–2 shows the automotive-grade Cyclone III device ordering codes and their equivalent timing specifications.

Table 8–2. Automotive-Grade Ordering Codes and Their Equivalent Timing Specifications for Cyclone III Devices

Automotive-Grade Device Ordering Code	Device Timing Specification		
	Device	Junction Temperature Range	Speed Grade
EP3C5E144A7N	EP3C5	–40°C to 125°C	–7
EP3C5F256A7N	EP3C5	–40°C to 125°C	–7
EP3C5U256A7N	EP3C5	–40°C to 125°C	–7
EP3C10E144A7N	EP3C10	–40°C to 125°C	–7
EP3C10F256A7N	EP3C10	–40°C to 125°C	–7
EP3C10U256A7N	EP3C10	–40°C to 125°C	–7
EP3C16E144A7N	EP3C16	–40°C to 125°C	–7
EP3C16F256A7N	EP3C16	–40°C to 125°C	–7
EP3C16U256A7N	EP3C16	–40°C to 125°C	–7
EP3C16F484A7N	EP3C16	–40°C to 125°C	–7
EP3C16U484A7N	EP3C16	–40°C to 125°C	–7
EP3C25E144A7N	EP3C25	–40°C to 125°C	–7
EP3C25F256A7N	EP3C25	–40°C to 125°C	–7
EP3C25U256A7N	EP3C25	–40°C to 125°C	–7
EP3C25F324A7N	EP3C25	–40°C to 125°C	–7
EP3C40F324A7N	EP3C40	–40°C to 125°C	–7
EP3C40F484A7N	EP3C40	–40°C to 125°C	–7
EP3C40U484A7N	EP3C40	–40°C to 125°C	–7

Pin-Out Information

- For more information about the Cyclone III device pin-outs, refer to the [Cyclone III Device Pin-Out Files](#) page.

Package and Board Layout Information

- For package-related information (for example, dimensions and thermal resistance values) on Cyclone III devices, refer to the *Package Information for Cyclone III Devices* chapter in volume 1 of the *Cyclone III Device Handbook*.
- For PCB design guidelines, refer to *AN114: Designing With High-Density BGA Packages for Altera Devices*.
- If you are designing PCBs with the Cadence OrCAD Capture component information system, you can download the symbol libraries from the [Cadence Capture CIS and Allegro PCB Symbols and Footprints](#) page.

Document Revision History

Table 8-3 lists the revision history for this chapter.

Table 8-3. Document Revision History

Date	Version	Changes
September 2013	3.4	No update.
June 2013	3.3	No update.
May 2013	3.2	No update.
February 2013	3.1	No update.
January 2013	3.0	Cyclone III devices are now listed under legacy support.
May 2011	2.0	No update.
March 2010	1.2	Removed Referenced Documents section.
October 2008	1.1	<ul style="list-style-type: none"> ■ Converted to new template. ■ Updated “DC and Timing Specifications” section.
February 2008	1.0	Initial release.

Supported Automotive-Grade Devices

Altera offers legacy support for Cyclone® II devices in the automotive temperature range. These devices are available in the –7 speed grade.

Legacy support provides existing customers with full production and technical support, while new customers should contact the nearest Altera sales representative for possible alternatives.

Table 9–1 lists the automotive-grade devices in the Cyclone II device family.

Table 9–1. Automotive-Grade in Cyclone II Devices

Device Ordering Code	Package
EP2C5AT144A7N	144-Pin TQFP
EP2C5AF256A7N	256-Pin FineLine BGA
EP2C8AF256A7N	256-Pin FineLine BGA
EP2C15AF256A7N	256-Pin FineLine BGA
EP2C15AF484A7N	484-Pin FineLine BGA
EP2C20AF256A7N	256-Pin FineLine BGA
EP2C20AF484A7N	484-Pin FineLine BGA

This chapter contains the following sections:

- “Device Ordering Codes” on page 9–2
- “Quartus II Software Support” on page 9–2
- “Power Analysis and Estimation” on page 9–3
- “DC and Timing Specifications” on page 9–4
- “Pin-Out Information” on page 9–5
- “Package and Board Layout Information” on page 9–5

Device Ordering Codes

Figure 9-1 shows the ordering codes for automotive-grade devices offered in the Cyclone II device family.

 For more information about a specific package, refer to the [Package Information Datasheet for Altera Devices](#).

Figure 9-1. Automotive-Grade Ordering Information for Cyclone II Devices



Quartus II Software Support

Legacy support for Cyclone II automotive grade devices in Altera® Quartus® II design software requires special approval. Contact the nearest Altera sales representative to submit your request.

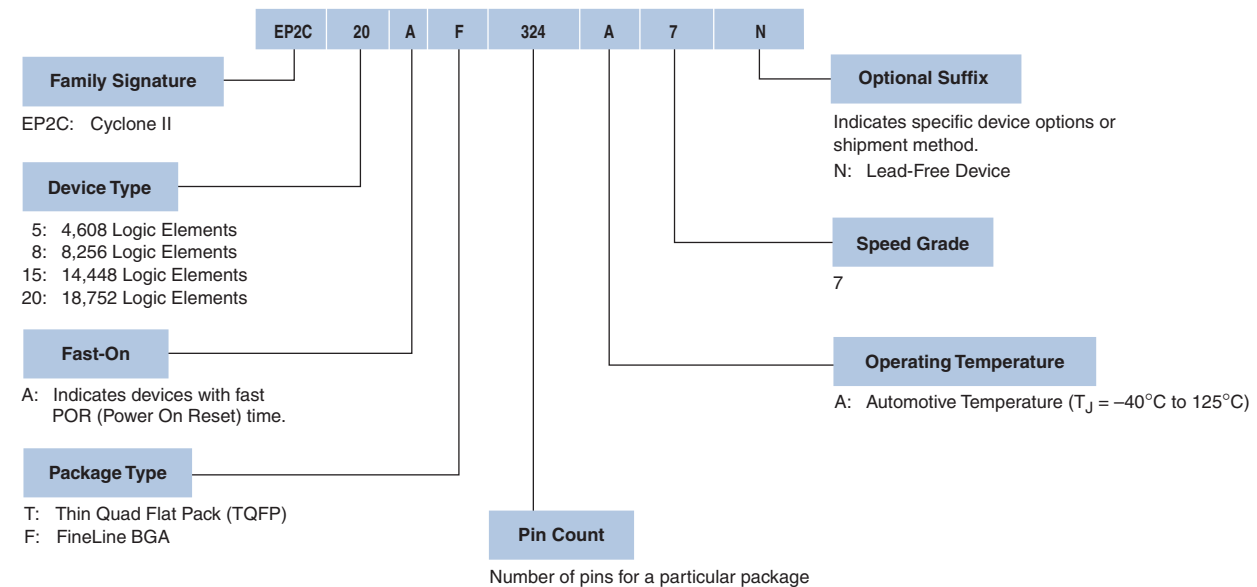
The Quartus II software provides a comprehensive environment for system on a chip (SoC) design. It also includes HDL and schematic design entry, compilation and logic synthesis, full simulation and advanced timing analysis, SignalTap™ II logic analyzer, and device configuration.

 For more information about the Quartus II software features, refer to the [Quartus II Handbook](#).

To target an automotive-grade Cyclone II device in your design in the Quartus II software, follow these steps:

1. On the Assignments menu, click **Device**. The **Settings** dialog box appears.
2. In the **Family** drop-down list, select **Cyclone II**.
3. Under Target device, select **Specific device selected in 'Available devices' list**.

4. In the **Available devices** list, select the appropriate ordering code, as listed in [Table 9-1](#).



The Quartus II software does not show the “N” suffix, which indicates a lead-free device. For example, the EP2C5AT144A7N device is shown only as EP2C5AT144A7.

5. Click **OK**.



Support for the automotive-grade Cyclone II devices is only available in the Quartus II software version 7.2 SP1 and later.

Power Analysis and Estimation

Altera provides the following power analysis and estimation tools for your design:

- [“PowerPlay Early Power Estimator”](#)
- [“PowerPlay Power Analyzer”](#)

PowerPlay Early Power Estimator

The PowerPlay Early Power Estimator (EPE) is a power estimation tool that helps you estimate the power consumption of your design during the system planning phase for proper power supply planning and consideration. The EPE allows you to enter design information based on architectural features and calculates the power consumed by each architectural feature. Inputs to the EPE are environmental conditions and device resources (such as clock frequency, RAM blocks, and digital signal processing [DSP] blocks) that you expect to use in your design. The EPE then calculates the static and dynamic power, current estimates, and thermal analysis for your design.

You can either enter the design information manually into the spreadsheet or import a power estimator file of a fully or partially completed design from the Quartus II software. After importing a file, you can edit some of the input parameters including V_{CCINT} , ambient temperature, airflow, clock frequency, and toggle percentage to suit your system requirements.



The value obtained from the EPE is only an estimation and should not be used as a specification. The accuracy of the EPE results depends on how close your input of the design information into the EPE resembles that of the final design.



For more information about the EPE, and how to generate and import the power estimator file, refer to the [PowerPlay Early Power Estimator User Guide for Cyclone II FPGAs](#).

PowerPlay Power Analyzer

The PowerPlay Power Analyzer tool in the Quartus II software is a power analysis tool that helps you calculate your design power consumption accurately to ensure thermal and power supply budgets are not violated after your design is complete. The PowerPlay Power Analyzer tool requires your design to be synthesized and fitted to the target device. Availability of information such as design resources, how the design is placed and routed on the target device, and the I/O standards assigned to each I/O cell allow the PowerPlay Power Analyzer tool to provide accurate power estimation.

The process of using the PowerPlay Power Analyzer tool consists of three parts—specifying sources of input data, specifying operating conditions, and running the PowerPlay Power Analyzer tool.

The input data consists of the signal activities data (toggle rates and static probabilities) of the compiled design. Signal activity data can be derived from simulation results, user assignment in the Assignment Editor, user-defined default toggle rate, and vectorless estimation.

The operating conditions include device power characteristic, ambient and junction temperature, cooling solution, and board thermal model, all of which can be set in the Quartus II software.

The PowerPlay Power Analyzer tool calculates the dynamic, static and I/O thermal power consumption, current consumed from voltage source, a summary of the signal activities used for analysis, and a confidence metric that reflects the overall quality of the data sources for the signal activities.

 For more information about the PowerPlay Power Analyzer tool, refer to the *PowerPlay Power Analysis* chapter in volume 3 of the *Quartus II Handbook*.

DC and Timing Specifications

The automotive-grade Cyclone II devices have the same absolute maximum ratings, recommended operating conditions, and DC electrical characteristics as those published for the Cyclone II devices in the *DC Characteristics and Timing Specifications* chapter of the *Cyclone II Device Handbook*.

For on-chip series termination (R_S OCT), use the tolerance values for extended-temperature devices as the tolerance values for the automotive-grade Cyclone II devices.

 For the timing specifications of the automotive-grade Cyclone II devices, refer to the *DC Characteristics and Timing Specifications* chapter of the *Cyclone II Device Handbook*.

The automotive-grade devices meet these timing specifications over the automotive temperature range ($T_j = -40^\circ\text{C}$ to 125°C). The fast corner timing specifications of the automotive-grade Cyclone II devices are the same as those of their corresponding industrial-grade devices.

Table 9–2 lists the automotive-grade ordering codes and their equivalent timing specifications for Cyclone II devices.

Table 9–2. Automotive-Grade Ordering Codes and Their Equivalent Timing Specifications for Cyclone II Devices

Automotive-Grade Device Ordering Code	Device Timing Specification		
	Device	Junction Temperature Range	Speed Grade
EP2C5AT144A7N	EP2C5	–40°C to 125°C	–7
EP2C5AF256A7N	EP2C5	–40°C to 125°C	–7
EP2C8AF256A7N	EP2C8	–40°C to 125°C	–7
EP2C15AF256A7N	EP2C15	–40°C to 125°C	–7
EP2C15AF484A7N	EP2C15	–40°C to 125°C	–7
EP2C20AF256A7N	EP2C20	–40°C to 125°C	–7

Pin-Out Information

- For more information about the Cyclone II device pin-outs, refer to the [Cyclone II Device Pin-Out Files](#) page.

Package and Board Layout Information

- For package-related information (for example, dimensions and thermal resistance values) on Cyclone II devices, refer to the [Package Information Datasheet for Altera Devices](#).
- For PCB design guidelines, refer to [AN114: Designing With High-Density BGA Packages for Altera Devices](#).
- If you are designing PCBs with the Cadence OrCAD capture component information system, you can download the symbol libraries from the [Cadence Capture CIS and Allegro PCB Symbols and Footprints](#) page.

Document Revision History

Table 9–3 lists the revision history for this chapter.

Table 9–3. Document Revision History (Part 1 of 2)

Date	Version	Changes
September 2013	3.4	No update.
June 2013	3.3	No update.
May 2013	3.2	No update.
February 2013	3.1	No update.
January 2013	3.0	Cyclone II devices are now listed under legacy support.
May 2011	2.0	<ul style="list-style-type: none"> ■ Template conversion. ■ Minor text edits.

Table 9-3. Document Revision History (Part 2 of 2)

Date	Version	Changes
March 2010	1.2	Removed Referenced Documents section.
October 2008	1.1	<ul style="list-style-type: none">■ Converted to new template.■ Updated “DC and Timing Specifications” section.
February 2008	1.0	Initial release.

Supported Automotive-Grade Devices

Altera offers legacy support for Cyclone® devices in the automotive temperature range. These devices are available only in the –8 speed grade.

Legacy support provides existing customers with full production and technical support, while new customers should contact the nearest Altera sales representative for possible alternatives.

Table 10–1 lists the automotive-grade devices in the Cyclone device family.

Table 10–1. Automotive-Grade in Cyclone Devices

Device Ordering Code	Package
EP1C3T100A8N	100-Pin TQFP
EP1C3T144A8N	144-Pin TQFP

This chapter contains the following sections:

- “Device Ordering Codes” on page 10–2
- “Quartus II Software Support” on page 10–2
- “Power Analysis and Estimation” on page 10–3
- “DC and Timing Specifications” on page 10–4
- “Pin-Out Information” on page 10–5
- “Package and Board Layout Information” on page 10–5

Device Ordering Codes

Figure 10-1 shows the ordering codes for automotive-grade devices offered in the Cyclone device family.

 For more information on a specific package, refer to the *Package Information Datasheet for Altera Devices*.

Figure 10-1. Automotive-Grade Ordering Information for Cyclone Devices



Quartus II Software Support

Legacy support for Cyclone automotive grade devices in Altera® Quartus® II design software requires special approval. Contact the nearest Altera sales representative to submit your request.

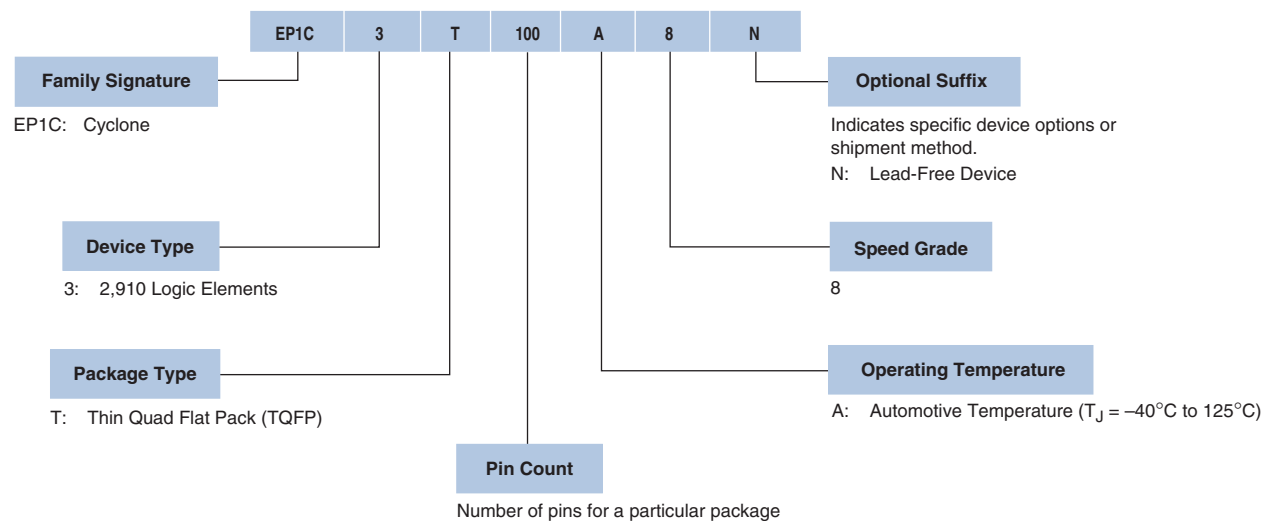
The Quartus II software provides a comprehensive environment for system on a chip (SoC) design. It also includes HDL and schematic design entry, compilation and logic synthesis, full simulation and advanced timing analysis, SignalTap™ II logic analyzer, and device configuration.

 For more information about the Quartus II software features, refer to the *Quartus II Handbook*.

To target an automotive-grade Cyclone device in your design in the Quartus II software, follow these steps:

1. On the Assignments menu, click **Device**. The **Settings** dialog box appears.
2. In the **Family** drop-down list, select **Cyclone**.
3. Under Target device, select **Specific device selected in 'Available devices' list**.

4. In the **Available devices** list, select the appropriate ordering code, as listed in [Table 10-1](#).



The Quartus II software does not show the “N” suffix, which indicates a lead-free device. For example, the EP1C3T100A8N device is shown only as EP1C3T100A8.

5. Click **OK**.



Support for the automotive-grade Cyclone devices is only available in the Quartus II software version 7.2 SP1 and later.

Power Analysis and Estimation

Altera provides the following power analysis and estimation tools for your design:

- “PowerPlay Early Power Estimator”
- “PowerPlay Power Analyzer”

PowerPlay Early Power Estimator

The PowerPlay Early Power Estimator (EPE) is a power estimation tool that helps you estimate the power consumption of your design during the system planning phase for proper power supply planning and consideration. The EPE allows you to enter design information based on architectural features and calculates the power consumed by each architectural feature. Inputs to the EPE are environmental conditions and device resources (such as clock frequency, RAM blocks, and digital signal processing [DSP] blocks) that you expect to use in your design. The EPE then calculates the static and dynamic power, current estimates, and thermal analysis for your design.

You can either enter the design information manually into the spreadsheet or import a power estimator file of a fully or partially completed design from the Quartus II software. After importing a file, you can edit some of the input parameters including V_{CCINT} , ambient temperature, airflow, clock frequency, and toggle percentage to suit your system requirements.



The value obtained from the EPE is only an estimation and should not be used as a specification. The accuracy of the EPE results depends on how close your input of the design information into the EPE resembles that of the final design.



For more information about the EPE, and how to generate and import the power estimator file, refer to the *PowerPlay Early Power Estimator User Guide for Stratix, Stratix GX, and Cyclone FPGAs*.

PowerPlay Power Analyzer

The PowerPlay Power Analyzer tool in the Quartus II software is a power analysis tool that helps you calculate your design power consumption accurately to ensure thermal and power supply budgets are not violated after your design is complete. The PowerPlay Power Analyzer tool requires your design to be synthesized and fitted to the target device. Availability of information such as design resources, how the design is placed and routed on the target device, and the I/O standards assigned to each I/O cell allow the PowerPlay Power Analyzer tool to provide accurate power estimation.

The process of using the PowerPlay Power Analyzer tool consists of three parts—specifying sources of input data, specifying operating conditions, and running the PowerPlay Power Analyzer tool.

The input data consists of the signal activities data (toggle rates and static probabilities) of the compiled design. Signal activity data can be derived from simulation results, user assignment in the Assignment Editor, user-defined default toggle rate, and vectorless estimation.

The operating conditions include device power characteristic, ambient and junction temperature, cooling solution, and board thermal model, all of which can be set in the Quartus II software.

The PowerPlay Power Analyzer tool calculates the dynamic, static and I/O thermal power consumption, current consumed from voltage source, a summary of the signal activities used for analysis, and a confidence metric that reflects the overall quality of the data sources for the signal activities.



For more information about the PowerPlay Power Analyzer tool, refer to the *PowerPlay Power Analysis* chapter in volume 3 of the *Quartus II Handbook*.

DC and Timing Specifications

Automotive-grade Cyclone devices have the same absolute maximum ratings, recommended operating conditions, and DC electrical characteristics as those published for the Cyclone devices in the *DC and Switching Characteristics* chapter of the *Cyclone Device Handbook*. For the maximum power-up current (I_{CCINT}) required to power up an automotive-grade Cyclone device, use the value specified for the corresponding industrial-grade device.

The timing specifications of the automotive-grade Cyclone devices are the same as those published for the Cyclone devices in the *DC and Switching Characteristics* chapter of the *Cyclone Device Handbook*. The automotive-grade devices meet these timing specifications over the automotive temperature range ($T_j = -40^{\circ}\text{C}$ to 125°C).

Table 10–2 lists the automotive-grade ordering codes and their equivalent timing specifications for Cyclone devices.

Table 10–2. Automotive-Grade Ordering Codes and Their Equivalent Timing Specifications for Cyclone Devices

Automotive-Grade Device Ordering Code	Device Timing Specification		
	Device	Junction Temperature Range	Speed Grade
EP1C3T100A8N	EP1C3	–40°C to 125°C	–8
EP1C3T144A8N	EP1C3	–40°C to 125°C	–8

Pin-Out Information

- For more information about the Cyclone device pin-outs, refer to the [Cyclone Device Pin-Out Files](#) page.

Package and Board Layout Information

- For package-related information (for example, dimensions and thermal resistance values) on Cyclone devices, refer to the [Package Information Datasheet for Altera Devices](#).
- For PCB design guidelines, refer to [AN114: Designing With High-Density BGA Packages for Altera Devices](#).
- If you are designing PCBs with the Cadence OrCAD capture component information system, you can download the symbol libraries from the [Cadence Capture CIS and Allegro PCB Symbols and Footprints](#) page.

Document Revision History

Table 10–3 lists the revision history for this chapter.

Table 10–3. Document Revision History

Date	Version	Changes
September 2013	3.4	No update.
June 2013	3.3	No update.
May 2013	3.2	No update.
February 2013	3.1	No update.
January 2013	3.0	Cyclone devices are now listed under legacy support.
May 2011	2.0	<ul style="list-style-type: none"> ■ Template conversion. ■ Minor text edits.
March 2010	1.2	Removed Referenced Documents section.
October 2008	1.1	Converted to new template.
February 2008	1.0	Initial release.

Supported Automotive-Grade Devices

Altera offers legacy support for MAX[®] 7000A devices in the automotive temperature range. These devices are available only in the –10 speed grade.

Legacy support provides existing customers with full production and technical support, while new customers should contact the nearest Altera sales representative for possible alternatives.

Table 11–1 lists the automotive-grade devices in the MAX 7000A device family.

Table 11–1. Automotive-Grade in MAX 7000A Devices

Device Ordering Code	Package
EPM7032AETA44-10N	44-Pin TQFP
EPM7064AETA44-10N	44-Pin TQFP
EPM7064AETA100-10N	100-Pin TQFP
EPM7128AETA100-10N	100-Pin TQFP
EPM7128AETA144-10N	144-Pin TQFP

This chapter contains the following sections:

- “Device Ordering Codes” on page 11–2
- “Quartus II Software Support” on page 11–2
- “Power Analysis and Estimation” on page 11–3
- “DC and Timing Specifications” on page 11–4
- “Pin-Out Information” on page 11–4
- “Package and Board Layout Information” on page 11–5

Device Ordering Codes

Figure 11-1 shows the ordering codes for automotive-grade devices offered in the MAX 7000A device family.

 For more information about a specific package, refer to the [Package Information Datasheet for Altera Devices](#).

Figure 11-1. Automotive-Grade Ordering Information for MAX 7000A Devices



Quartus II Software Support

Legacy support for MAX 7000A automotive grade devices in Altera® Quartus® II design software requires special approval. Contact the nearest Altera sales representative to submit your request.

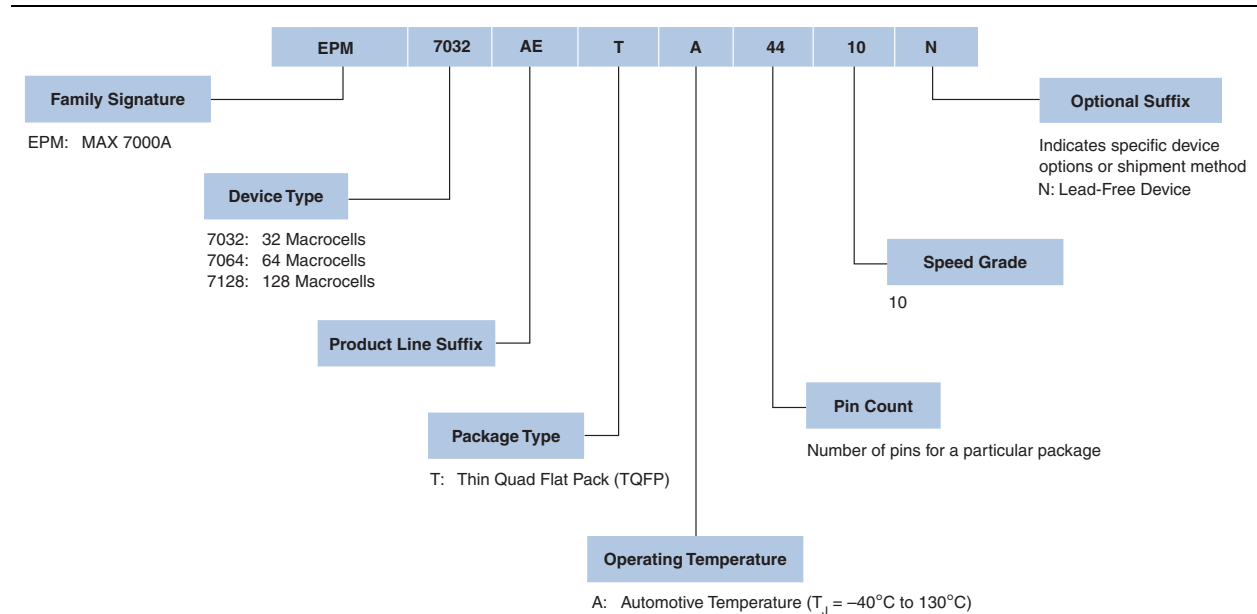
The Quartus II software includes HDL and schematic design entry, compilation and logic synthesis, full simulation and advanced timing analysis, and device programming.

 For more information about the Quartus II software features, refer to the [Quartus II Handbook](#).

To target an automotive-grade MAX 7000A device in your design in the Quartus II software, follow these steps:

1. On the Assignments menu, click **Device**. The **Settings** dialog box appears.
2. In the **Family** drop-down list, select **MAX7000AE**.
3. Under Target device, select **Specific device selected in 'Available devices' list**.

4. In the **Available devices** list, select the appropriate ordering code, as listed in [Table 11-1](#).



The Quartus II software does not show the “N” suffix, which indicates a lead-free device. For example, the EPM7032AETA44-10N device is shown only as EPM7032AETA44-10.

5. Click **OK**.



Support for the automotive-grade MAX 7000A devices is only available in the Quartus II software version 7.2 SP1 and later.

Power Analysis and Estimation

Altera provides the following power analysis and estimation tools for your design:

- “PowerPlay Early Power Estimator”
- “PowerPlay Power Analyzer”

PowerPlay Early Power Estimator

The PowerPlay Early Power Estimator (EPE) is a power estimation tool that helps you estimate the power consumption of your design during the system planning phase for proper power supply planning and consideration. The EPE allows you to enter design information based on architectural features and calculates the power consumed by each architectural feature. Inputs to the EPE are environmental conditions and device resources (such as clock frequency) that you expect to use in your design. The EPE then calculates the static and dynamic power, current estimates, and thermal analysis for your design.

You can either enter the design information manually into the spreadsheet or import a power estimator file of a fully or partially completed design from the Quartus II software. After importing a file, you can edit some of the input parameters including V_{CCINT} , ambient temperature, airflow, clock frequency, and toggle percentage to suit your system requirements.



The value obtained from the EPE is only an estimation and should not be used as a specification. The accuracy of the EPE results depends on how close your input of the design information into the EPE resembles that of the final design.

PowerPlay Power Analyzer

The PowerPlay Power Analyzer tool in the Quartus II software is a power analysis tool that helps you calculate your design power consumption accurately to ensure thermal and power supply budgets are not violated after your design is complete. The PowerPlay Power Analyzer tool requires your design to be synthesized and fitted to the target device. Availability of information such as design resources, how the design is placed and routed on the target device, and the I/O standards assigned to each I/O cell allow the PowerPlay Power Analyzer tool to provide accurate power estimation.

The process of using the PowerPlay Power Analyzer tool consists of three parts—specifying sources of input data, specifying operating conditions, and running the PowerPlay Power Analyzer tool.

The input data consists of the signal activities data (toggle rates and static probabilities) of the compiled design. Signal activity data can be derived from simulation results, user assignment in the Assignment Editor, user-defined default toggle rate, and vectorless estimation.

The operating conditions include device power characteristic, ambient and junction temperature, cooling solution, and board thermal model, all of which can be set in the Quartus II software.

The PowerPlay Power Analyzer tool calculates the dynamic, static and I/O thermal power consumption, current consumed from voltage source, a summary of the signal activities used for analysis, and a confidence metric that reflects the overall quality of the data sources for the signal activities.



For more information about the PowerPlay Power Analyzer tool, refer to the *PowerPlay Power Analysis* chapter in volume 3 of the *Quartus II Handbook*.

DC and Timing Specifications

Automotive-grade MAX 7000A devices have the same absolute maximum ratings, recommended operating conditions, and DC electrical characteristics as those published for the MAX 7000A devices in the *MAX 7000A Programmable Logic Device Data Sheet*.

The timing specifications of the automotive-grade MAX 7000A devices are the same as those published for the MAX 7000A devices in the *MAX 7000A Programmable Logic Device Data Sheet*. The automotive-grade devices meet these timing specifications over the automotive temperature range ($T_j = -40^\circ\text{C}$ to 130°C).

Table 11-2 lists the automotive-grade ordering codes and their equivalent timing specifications for MAX 7000A devices.

Table 11-2. Automotive-Grade Ordering Codes and Their Equivalent Timing Specifications for MAX 7000A Devices



Automotive-Grade Device Ordering Code	Device Timing Specification		
	Device	Junction Temperature Range	Speed Grade
EPM7032AETA44-10N	EPM7032AE	-40°C to 130°C	-10
EPM7064AETA44-10N	EPM7064AE	-40°C to 130°C	-10
EPM7064AETA100-10N	EPM7064AE	-40°C to 130°C	-10
EPM7128AETA100-10N	EPM7128AE	-40°C to 130°C	-10
EPM7128AETA144-10N	EPM7128AE	-40°C to 130°C	-10

Pin-Out Information



For more information about the MAX 7000A device pin-outs, refer to the *MAX 7000, MAX 7000A, and MAX 7000B Device Pin-Out Files* page.

Package and Board Layout Information

-  For package-related information (for example, dimensions and thermal resistance values) about MAX 7000A devices, refer to the *Package Information Datasheet for Altera Devices*.
-  For PCB design guidelines, refer to *AN114: Designing With High-Density BGA Packages for Altera Devices*.

Document Revision History

Table 11-3 lists the revision history for this chapter.

Table 11-3. Document Revision History

Date	Version	Changes
September 2013	3.4	No update.
June 2013	3.3	No update.
May 2013	3.2	No update.
February 2013	3.1	No update.
January 2013	3.0	MAX 7000A devices are now listed under legacy support.
May 2011	2.0	<ul style="list-style-type: none">■ Template conversion.■ Minor text edits.
March 2010	1.2	Removed Referenced Documents section.
October 2008	1.1	Converted to new template.
February 2008	1.0	Initial release.

This chapter provides additional information about the document and Altera.

How to Contact Altera

To locate the most up-to-date information about Altera products, refer to the following table.

Contact ⁽¹⁾	Contact Method	Address
Technical support	Website	www.altera.com/support
Technical training	Website	www.altera.com/training
	Email	custrain@altera.com
Product literature	Website	www.altera.com/literature
Nontechnical support (general) (software licensing)	Email	nacomp@altera.com
	Email	authorization@altera.com









Note to Table:

(1) You can also contact your local Altera sales office or sales representative.

Typographic Conventions

The following table shows the typographic conventions this document uses.

Visual Cue	Meaning
Bold Type with Initial Capital Letters	Indicate command names, dialog box titles, dialog box options, and other GUI labels. For example, Save As dialog box. For GUI elements, capitalization matches the GUI.
bold type	Indicates directory names, project names, disk drive names, file names, file name extensions, software utility names, and GUI labels. For example, <code>\qdesigns</code> directory, D: drive, and <code>chiptrip.gdf</code> file.
<i>Italic Type with Initial Capital Letters</i>	Indicate document titles. For example, <i>Stratix IV Design Guidelines</i> .
<i>italic type</i>	Indicates variables. For example, $n + 1$. Variable names are enclosed in angle brackets (< >). For example, <file name> and <project name>.pof file.
Initial Capital Letters	Indicate keyboard keys and menu names. For example, the Delete key and the Options menu.
“Subheading Title”	Quotation marks indicate references to sections in a document and titles of Quartus II Help topics. For example, “Typographic Conventions.”

Visual Cue	Meaning
Courier type	<p>Indicates signal, port, register, bit, block, and primitive names. For example, <code>data1</code>, <code>tdi</code>, and <code>input</code>. The suffix <code>n</code> denotes an active-low signal. For example, <code>resetn</code>.</p> <p>Indicates command line commands and anything that must be typed exactly as it appears. For example, <code>c:\qdesigns\tutorial\chiptrip.gdf</code>.</p> <p>Also indicates sections of an actual file, such as a Report File, references to parts of files (for example, the AHDL keyword <code>SUBDESIGN</code>), and logic function names (for example, <code>TRI</code>).</p>
	An angled arrow instructs you to press the Enter key.
1., 2., 3., and a., b., c., and so on	Numbered steps indicate a list of items when the sequence of the items is important, such as the steps listed in a procedure.
	Bullets indicate a list of items when the sequence of the items is not important.
	The hand points to information that requires special attention.
	The question mark directs you to a software help system with related information.
	The feet direct you to another document or website with related information.
	The multimedia icon directs you to a related multimedia presentation.
	A caution calls attention to a condition or possible situation that can damage or destroy the product or your work.
	A warning calls attention to a condition or possible situation that can cause you injury.
	The envelope links to the Email Subscription Management Center page of the Altera website, where you can sign up to receive update notifications for Altera documents.