

TRS202E 5-V Dual RS-232 Line Driver and Receiver With ± 15 -kV IEC ESD Protection

1 Features

- IEC61000-4-2 (Level 4) ESD Protection for RS-232 Bus Pins:
 - ± 8 -kV Contact Discharge
 - ± 15 -kV Air-Gap Discharge
 - ± 15 -kV Human-Body Model
- Meets or Exceeds the Requirements of TIA/EIA-232-F and ITU v.28 Standards
- Operates at 5-V V_{CC} Supply
- Operates Up to 120 kbit/s
- External Capacitors: $4 \times 0.1 \mu\text{F}$ or $4 \times 1 \mu\text{F}$
- Latch-Up Performance Exceeds 100 mA Per JESD 78, Class II

2 Applications

- Battery-Powered Systems
- Notebooks
- Laptops
- Set-Top Boxes
- Hand-Held Equipment

3 Description

The TRS202E device consists of two line drivers, two line receivers, and a dual charge-pump circuit. TRS202E has IEC61000-4-2 (Level 4) ESD protection pin-to-pin (serial-port connection pins, including GND). The device meets the requirements of TIA/EIA-232-F and provides the electrical interface between an asynchronous communication controller and the serial-port connector. The charge pump and four small external capacitors allow operation from a single 5-V supply. The device operates at data signaling rates up to 120 kbit/s and a maximum of 30-V/ μs driver output slew rate.

Device Information⁽¹⁾

PART NUMBER	PACKAGE	BODY SIZE (NOM)
TRS202ECD TRS202EID	SOIC (16)	9.90 mm x 3.91 mm
TRS202ECDW TRS202EIDW	SOIC (16)	10.30 mm x 7.50 mm
TRS202ECN TRS202EIN	PDIP (16)	19.30 mm x 6.35 mm
TRS202ECPW TRS202EIPW	TSSOP (16)	5.00 mm x 4.40 mm

(1) For all available packages, see the orderable addendum at the end of the data sheet.

Logic Diagram (Positive Logic)

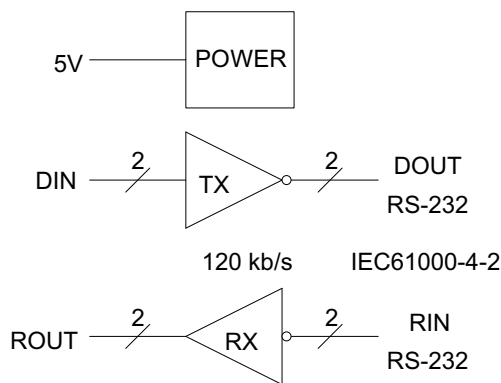

Copyright © 2016, Texas Instruments Incorporated



Table of Contents

1 Features	1	8 Detailed Description	9
2 Applications	1	8.1 Overview	9
3 Description	1	8.2 Functional Block Diagram	9
4 Revision History	2	8.3 Feature Description	9
5 Pin Configuration and Functions	3	8.4 Device Functional Modes	9
6 Specifications	4	9 Application and Implementation	11
6.1 Absolute Maximum Ratings	4	9.1 Application Information	11
6.2 ESD Ratings	4	9.2 Typical Application	11
6.3 Recommended Operating Conditions	4	10 Power Supply Recommendations	13
6.4 Thermal Information	5	11 Layout	13
6.5 Electrical Characteristics	5	11.1 Layout Guidelines	13
6.6 Electrical Characteristics: Driver	5	11.2 Layout Example	13
6.7 Electrical Characteristics: Receiver	5	12 Device and Documentation Support	14
6.8 Switching Characteristics: Driver	6	12.1 Receiving Notification of Documentation Updates	14
6.9 Switching Characteristics: Receiver	6	12.2 Community Resources	14
6.10 Typical Characteristics	6	12.3 Trademarks	14
7 Parameter Measurement Information	8	12.4 Electrostatic Discharge Caution	14
		12.5 Glossary	14

4 Revision History

NOTE: Page numbers for previous revisions may differ from page numbers in the current version.

Changes from Revision D (November 2012) to Revision E	Page
• Added <i>ESD Ratings</i> table, <i>Feature Description</i> section, <i>Device Functional Modes</i> , <i>Application and Implementation</i> section, <i>Power Supply Recommendations</i> section, <i>Layout</i> section, <i>Device and Documentation Support</i> section, and <i>Mechanical, Packaging, and Orderable Information</i> section	1
• Deleted <i>Ordering Information</i> table; see <i>Package Option Addendum</i> at the end of the data sheet	1
• Changed Package thermal impedance, $R_{\theta JA}$, values in Thermal Information table From: 73°C/W To: 76.7°C/W (D), From: 57°C/W To: 77.1°C/W (DW), From: 67°C/W To: 44.1°C/W (N), and From: 108°C/W To: 101.7°C/W (PW)	5

Changes from Revision C (May 2010) to Revision D	Page
• Fixed I_{OS} values typo in <i>Electrical Characteristics</i> table, changed – to ±	5

5 Pin Configuration and Functions

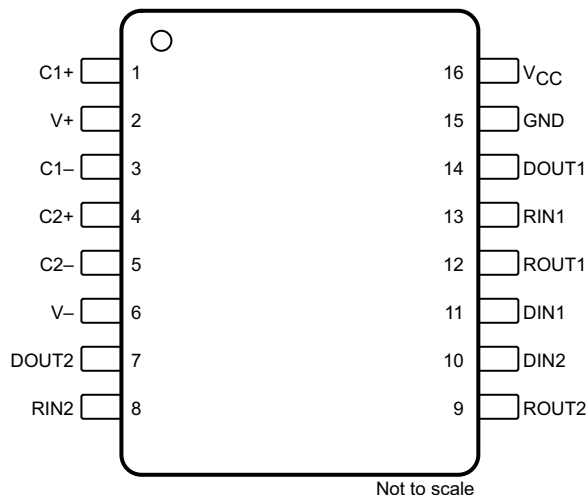

Pin Functions

PIN		I/O	DESCRIPTION
NO.	NAME		
1	C1+	—	Positive lead of C1 capacitor
2	V+	O	Positive charge pump output for storage capacitor only
3	C1-	—	Negative lead of C1 capacitor
4	C2+	—	Positive lead of C2 capacitor
5	C2-	—	Negative lead of C2 capacitor
6	V-	O	Negative charge pump output for storage capacitor only
7	DOUT2	O	RS-232 line data output (to remote RS-232 system)
8	RIN2	I	RS-232 line data input (from remote RS-232 system)
9	ROUT2	O	Logic data output (to UART)
10	DIN2	I	Logic data input (from UART)
11	DIN1	I	Logic data input (from UART)
12	ROUT1	O	Logic data output (to UART)
13	RIN1	I	RS-232 line data input (from remote RS-232 system)
14	DOUT1	O	RS-232 line data output (to remote RS-232 system)
15	GND	—	Ground
16	V _{CC}	—	Supply voltage, connect to external 5-V power supply

6 Specifications

6.1 Absolute Maximum Ratings

 over operating free-air temperature range (unless otherwise noted)⁽¹⁾⁽²⁾

		MIN	MAX	UNIT
Supply voltage, V_{CC} ⁽²⁾		-0.3	6	V
Positive charge pump voltage, V_+ ⁽²⁾		$V_{CC} - 0.3$	14	V
Negative charge pump voltage, V_-		-14	0.3	V
Input voltage, V_I	Drivers	-0.3	$V_+ + 0.3$	V
	Receivers		± 30	
Output voltage, V_O	Drivers	$V_- - 0.3$	$V_+ + 0.3$	V
	Receivers	-0.3	$V_{CC} + 0.3$	
Short-circuit duration, D_{OUT}		Continuous		
Operating virtual junction temperature, T_J			150	°C
Storage temperature, T_{stg}		-65	150	°C

- (1) Stresses beyond those listed under *Absolute Maximum Ratings* may cause permanent damage to the device. These are stress ratings only, which do not imply functional operation of the device at these or any other conditions beyond those indicated under *Recommended Operating Conditions*. Exposure to absolute-maximum-rated conditions for extended periods may affect device reliability.
- (2) All voltages are with respect to network GND.

6.2 ESD Ratings

			VALUE	UNIT
$V_{(ESD)}$ Electrostatic discharge	Human-body model (HBM), per ANSI/ESDA/JEDEC JS-001 ⁽¹⁾	Pins 7, 8, 13, 14, 15	± 15000	V
		All other pins	± 2000	
	Charged-device model (CDM), per JEDEC specification JESD22-C101 ⁽²⁾	All pins	± 1500	
	IEC 61000-4-2 contact discharge	Pins 7, 8, 13, 14, 15	± 8000	
	IEC 61000-4-2 air-gap discharge	Pins 7, 8, 13, 14, 15	± 15000	

- (1) JEDEC document JEP155 states that 500-V HBM allows safe manufacturing with a standard ESD control process.
- (2) JEDEC document JEP157 states that 250-V CDM allows safe manufacturing with a standard ESD control process.

6.3 Recommended Operating Conditions

 see [Figure 9](#)⁽¹⁾

			MIN	NOM	MAX	UNIT
Supply voltage			4.5	5	5.5	V
V_{IH}	Driver high-level input voltage (D_{IN})		2			V
V_{IL}	Driver low-level input voltage (D_{IN})				0.8	V
V_I	Driver input voltage (D_{IN})		0		5.5	V
	Receiver input voltage		-30		30	
T_A	Operating free-air temperature		TRS202EC		70	°C
			TRS202EI	-40	85	

- (1) Test conditions are C1 to C4 = 0.1 μ F at $V_{CC} = 5\text{ V} \pm 0.5\text{ V}$.

6.4 Thermal Information

THERMAL METRIC ⁽¹⁾	TRS202E				UNIT	
	D (SOIC)	DW (SOIC)	N (PDIP)	PW (TSSOP)		
	16 PINS	16 PINS	16 PINS	16 PINS		
R _{θJA}	Junction-to-ambient thermal resistance	76.7	77.1	44.1	101.7	°C/W
R _{θJC(top)}	Junction-to-case (top) thermal resistance	37.4	39.9	30.8	37	°C/W
R _{θJB}	Junction-to-board thermal resistance	34.2	41.8	24.2	46.6	°C/W
ψ _{JT}	Junction-to-top characterization parameter	7	12.9	15.2	2.8	°C/W
ψ _{JB}	Junction-to-board characterization parameter	33.9	41.3	24	46	°C/W

(1) For more information about traditional and new thermal metrics, see the [Semiconductor and IC Package Thermal Metrics](#) application report.

6.5 Electrical Characteristics

over recommended ranges of supply voltage and operating free-air temperature (unless otherwise noted; see [Figure 9](#))⁽¹⁾

PARAMETER	TEST CONDITIONS	MIN	TYP ⁽²⁾	MAX	UNIT	
I _{CC}	Supply current	No load, V _{CC} = 5 V		8	15	mA

(1) Test conditions are C1 to C4 = 0.1 μF at V_{CC} = 5 V + 0.5 V.

(2) All typical values are at V_{CC} = 5 V and T_A = 25°C.

6.6 Electrical Characteristics: Driver

over recommended ranges of supply voltage and operating free-air temperature (unless otherwise noted) (see [Figure 9](#))⁽¹⁾

PARAMETER	TEST CONDITIONS	MIN	TYP ⁽²⁾	MAX	UNIT	
V _{OH}	High-level output voltage	D _{OUT} at R _L = 3 kΩ to GND, D _{IN} = GND		5	9	V
V _{OL}	Low-level output voltage	D _{OUT} at R _L = 3 kΩ to GND, D _{IN} = V _{CC}		-5	-9	V
I _{IH}	High-level input current	V _I = V _{CC}		15	200	μA
I _{IL}	Low-level input current	V _I at 0 V		-15	-200	μA
I _{OS} ⁽³⁾	Short-circuit output current	V _{CC} = 5.5 V and V _O = 0 V		±10	±60	mA
r _o	Output resistance	V _{CC} , V ₊ , V ₋ = 0 V, and V _O = ±2 V		300		Ω

(1) Test conditions are C1 to C4 = 0.1 μF at V_{CC} = 5 V + 0.5 V.

(2) All typical values are at V_{CC} = 5 V and T_A = 25°C.

(3) Short-circuit durations must be controlled to prevent exceeding the device absolute power-dissipation ratings, and not more than one output must be shorted at a time.

6.7 Electrical Characteristics: Receiver

over recommended ranges of supply voltage and operating free-air temperature (unless otherwise noted; see [Figure 9](#))⁽¹⁾

PARAMETER	TEST CONDITIONS	MIN	TYP ⁽²⁾	MAX	UNIT		
V _{OH}	High-level output voltage	I _{OH} = -1 mA		3.5	V _{CC} - 0.4	V	
V _{OL}	Low-level output voltage	I _{OL} = 1.6 mA			0.4	V	
V _{IT+}	Positive-going input threshold voltage	V _{CC} = 5 V and T _A = 25°C		1.7	2.4	V	
V _{IT-}	Negative-going input threshold voltage	V _{CC} = 5 V and T _A = 25°C		0.8	1.2	V	
V _{hys}	Input hysteresis (V _{IT+} - V _{IT-})			0.2	0.5	1	V
r _i	Input resistance	V _I = ±3 V to ±25 V		3	5	7	kΩ

(1) Test conditions are C1 to C4 = 0.1 μF at V_{CC} = 5 V + 0.5 V.

(2) All typical values are at V_{CC} = 5 V and T_A = 25°C.

6.8 Switching Characteristics: Driver

over recommended ranges of supply voltage and operating free-air temperature (unless otherwise noted; see Figure 9)⁽¹⁾

PARAMETER	TEST CONDITIONS	MIN	TYP ⁽²⁾	MAX	UNIT
Maximum data rate	C _L = 50 to 1000 pF, one D _{OUT} switching, and R _L = 3 kΩ to 7 kΩ (see Figure 6)	120			kbit/s
t _{PLH(D)}	Propagation delay time, low- to high-level output C _L = 2500 pF, all drivers loaded, and R _L = 3 kΩ (see Figure 6)		2		μs
t _{PHL(D)}	Propagation delay time, high- to low-level output C _L = 2500 pF, all drivers loaded, and R _L = 3 kΩ (see Figure 6)		2		μs
t _{sk(p)}	Pulse skew ⁽³⁾ C _L = 150 to 2500 pF and R _L = 3 kΩ to 7 kΩ (see Figure 7)		300		ns
SR(tr)	Slew rate, transition region C _L = 50 to 1000 pF, V _{CC} = 5 V, and R _L = 3 kΩ to 7 kΩ (see Figure 6)	3	6	30	V/μs

- (1) Test conditions are C1 to C4 = 0.1 μF at V_{CC} = 5 V + 0.5 V.
- (2) All typical values are at V_{CC} = 5 V and T_A = 25°C.
- (3) Pulse skew is defined as |t_{PLH} - t_{PHL}| of each channel of the same device.

6.9 Switching Characteristics: Receiver

over recommended ranges of supply voltage and operating free-air temperature (unless otherwise noted; see Figure 8)⁽¹⁾

PARAMETER	TEST CONDITIONS	MIN	TYP ⁽²⁾	MAX	UNIT
t _{PLH(R)}	Propagation delay time, low- to high-level output C _L = 150 pF		0.5	10	μs
t _{PHL(R)}	Propagation delay time, high- to low-level output C _L = 150 pF		0.5	10	μs
t _{sk(p)}	Pulse skew ⁽³⁾		300		ns

- (1) Test conditions are C1 to C4 = 0.1 μF at V_{CC} = 5 V + 0.5 V.
- (2) All typical values are at V_{CC} = 5 V and T_A = 25°C.
- (3) Pulse skew is defined as |t_{PLH} - t_{PHL}| of each channel of the same device.

6.10 Typical Characteristics

T_A = 25°C (unless otherwise noted)

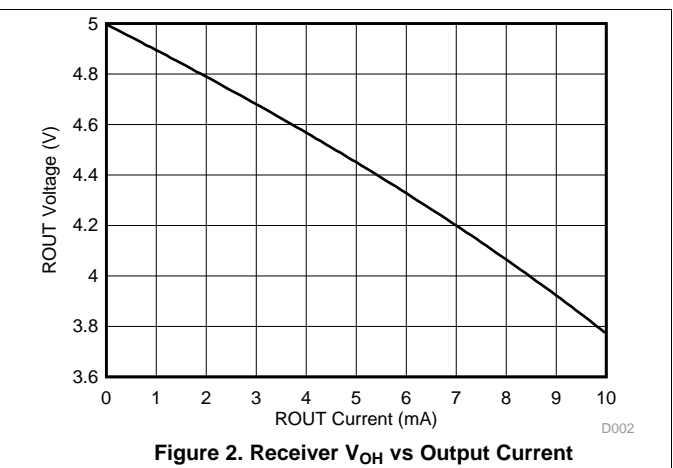
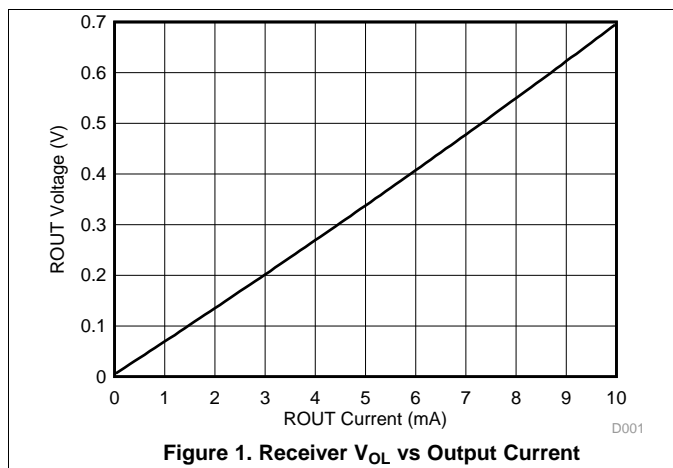

Typical Characteristics (continued)

T_A = 25°C (unless otherwise noted)

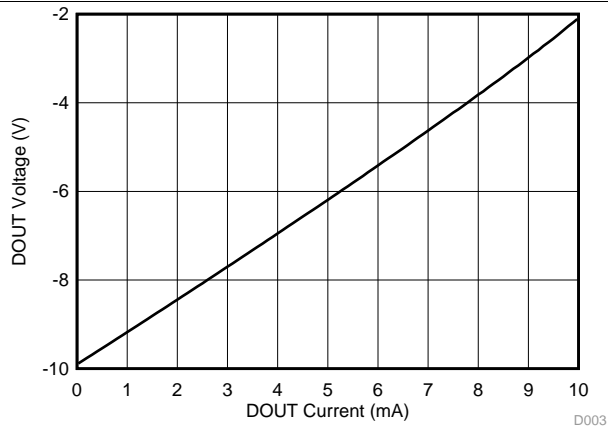

Figure 3. Driver V_{OL} vs Output Current

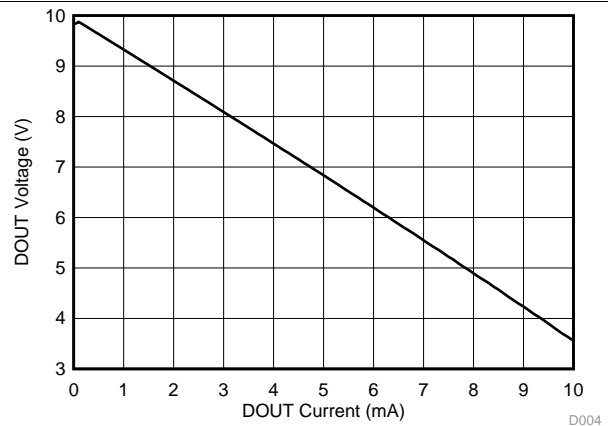

Figure 4. Driver V_{OH} vs Output Current

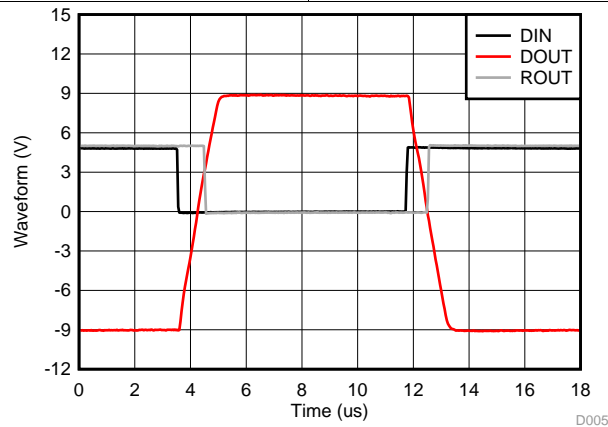
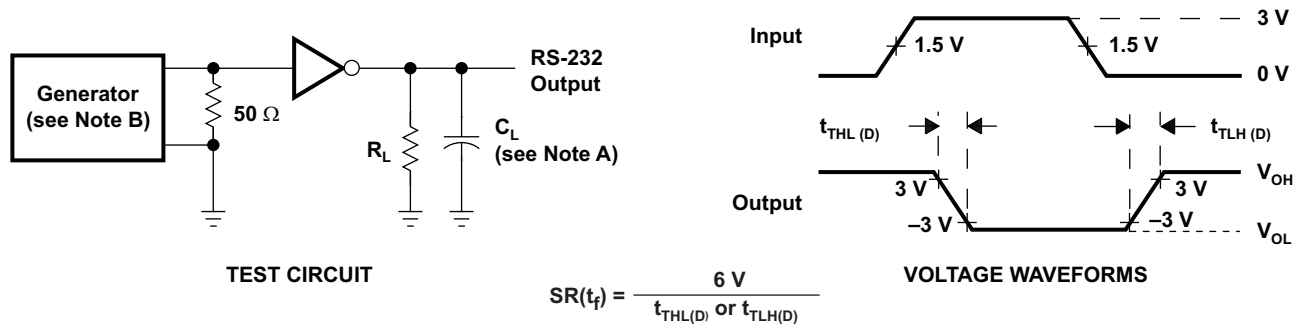

Figure 5. Driver and Receiver Loopback Waveforms

7 Parameter Measurement Information



NOTES: A. C_L includes probe and jig capacitance.

B. The pulse generator has the following characteristics: PRR = 120 kbit/s, $Z_O = 50\ \Omega$, 50% duty cycle, $t_r \leq 10\text{ ns}$, $t_f \leq 10\text{ ns}$.

Figure 6. Driver Slew Rate

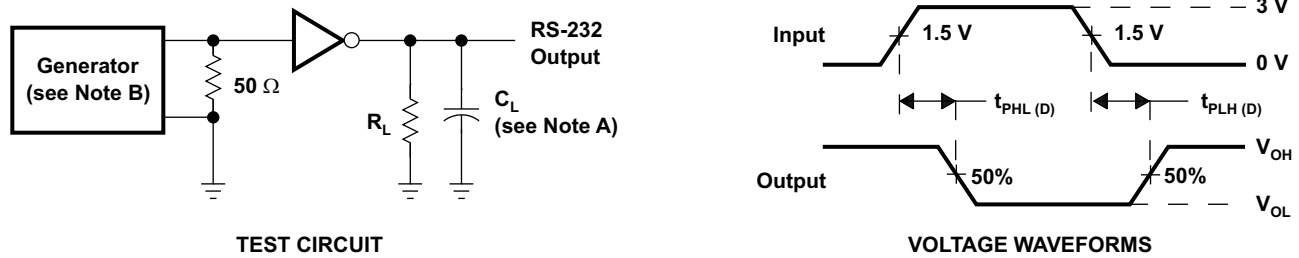

NOTES: A. C_L includes probe and jig capacitance.

B. The pulse generator has the following characteristics: PRR = 120 kbit/s, $Z_O = 50\ \Omega$, 50% duty cycle, $t_r \leq 10\text{ ns}$, $t_f \leq 10\text{ ns}$.

Figure 7. Driver Pulse Skew

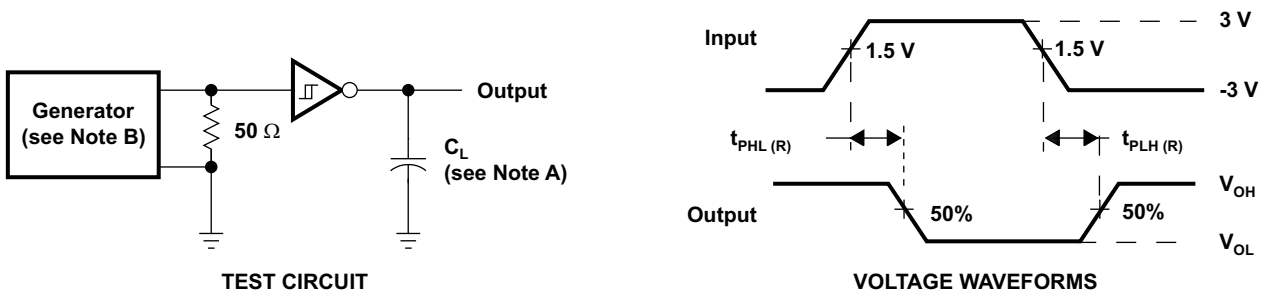

NOTES: A. C_L includes probe and jig capacitance.

B. The pulse generator has the following characteristics: $Z_O = 50\ \Omega$, 50% duty cycle, $t_r \leq 10\text{ ns}$, $t_f \leq 10\text{ ns}$.

Figure 8. Receiver Propagation Delay Times

8 Detailed Description

8.1 Overview

The TRS202E device is a dual driver and receiver that includes a capacitive voltage generator using four capacitors to supply TIA/EIA-232-F voltage levels from a single 5-V supply. All RS-232 pins have 15-kV HBM and IEC61000-4-2 Air-Gap discharge protection. RS-232 pins also have 8-kV IEC61000-4-2 contact discharge protection. Each receiver converts TIA/EIA-232-F inputs to 5-V TTL/CMOS levels. These receivers have shorted and open fail safe. The receiver can accept up to ± 30 -V inputs and decode inputs as low as ± 3 V. Each driver converts TTL/CMOS input levels into TIA/EIA-232-F levels. Outputs are protected against shorts to ground.

8.2 Functional Block Diagram

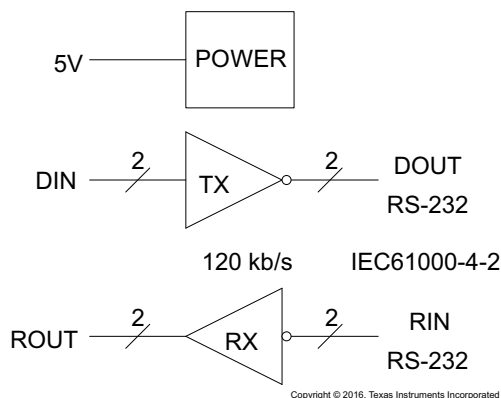

8.3 Feature Description

8.3.1 Power

The power block increases and inverts the 5-V supply for the RS-232 driver using a charge pump that requires four 0.1- μ F or 1- μ F external capacitors.

8.3.2 RS-232 Driver

Two drivers interface standard logic levels to RS-232 levels. The driver inputs do not have internal pullup resistors. Do not float the driver inputs.

8.3.3 RS-232 Receiver

Two Schmitt trigger receivers interface RS-232 levels to standard logic levels. Each receiver has an internal 5-k Ω load to ground. An open input results in a high output on R_{OUT}.

8.4 Device Functional Modes

8.4.1 V_{CC} Powered by 5 V

The device is in normal operation when powered by 5 V.

8.4.2 V_{CC} Unpowered

When TRS202E is unpowered, it can be safely connected to an active remote RS-232 device.

8.4.3 Truth Tables

[Table 1](#) and [Table 2](#) list the function for each driver and receiver (respectively).

Table 1. Function Table for Each Driver⁽¹⁾

INPUT DIN	OUTPUT DOUT
L	H
H	L

(1) H = high level, L = low level

Table 2. Function Table for Each Receiver⁽¹⁾

INPUT RIN	OUTPUT ROUT
L	H
H	L
Open	H

(1) H = high level, L = low level,
Open = input disconnected or connected driver off

9 Application and Implementation

NOTE

Information in the following applications sections is not part of the TI component specification, and TI does not warrant its accuracy or completeness. TI's customers are responsible for determining suitability of components for their purposes. Customers should validate and test their design implementation to confirm system functionality.

9.1 Application Information

For proper operation, add capacitors as shown in Figure 9. Pins 9 through 12 connect to UART or general purpose logic lines. RS-232 lines on pins 7, 8, 13, and 14 connect to a connector or cable.

9.2 Typical Application

Two driver and two receiver channels are supported for full duplex transmission with hardware flow control. The two 5kΩ-resistors are internal to the TRS202E.

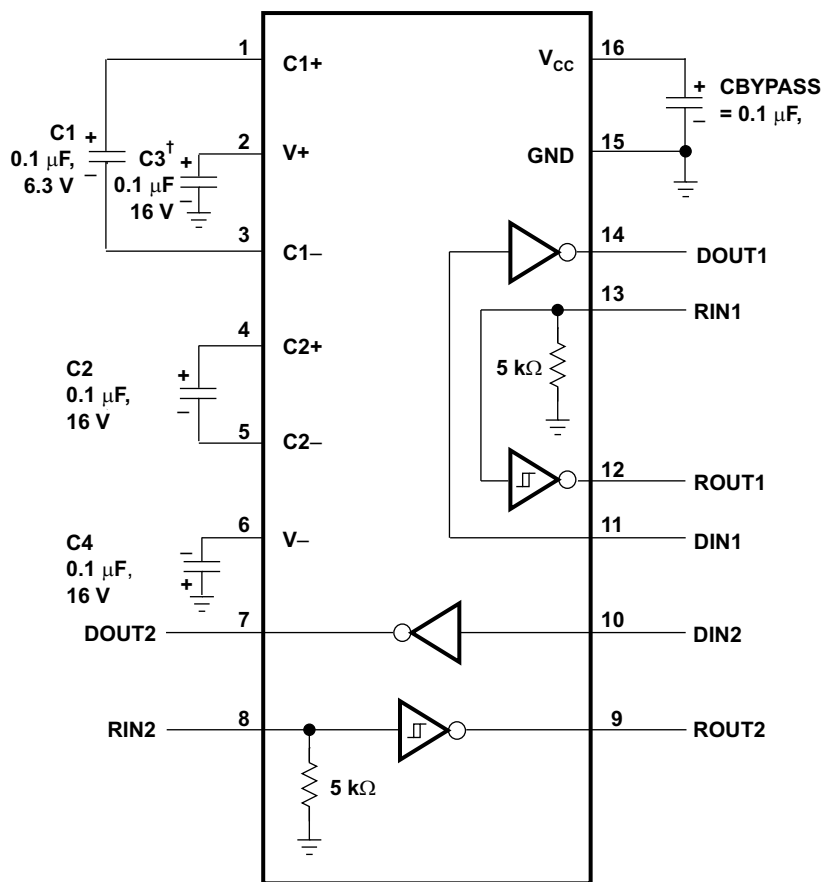

[†] C3 can be connected to V_{CC} or GND.

NOTES: A. Resistor values shown are nominal.

B. Nonpolarized ceramic capacitors are acceptable. If polarized tantalum or electrolytic capacitors are used, they should be connected as shown.

Copyright © 2016, Texas Instruments Incorporated

Figure 9. Typical Operating Circuit and Capacitor Values

Typical Application (continued)

9.2.1 Design Requirements

- V_{CC} minimum is 4.5 V and maximum is 5.5 V.
- Maximum recommended bit rate is 120 kbps.

9.2.2 Detailed Design Procedure

9.2.2.1 Capacitor Selection

The capacitor type used for C1 through C4 is not critical for proper operation. The TRS202E requires 0.1- μ F capacitors. 1- μ F capacitors are also acceptable. TI recommends ceramic dielectrics. When using the minimum recommended capacitor values, ensure the capacitance value does not degrade excessively as the operating temperature varies. If in doubt, use capacitors with a larger (for example, 2 \times) nominal value. The capacitors' effective series resistance (ESR), which usually rises at low temperatures, influences the amount of ripple on V_+ and V_- .

Bypass V_{CC} to ground with at least 0.1 μ F. In applications sensitive to power-supply noise generated by the charge pumps, decouple V_{CC} to ground with a capacitor the same size as (or larger than) the charge-pump capacitors (C1 to C4).

9.2.3 Application Curves

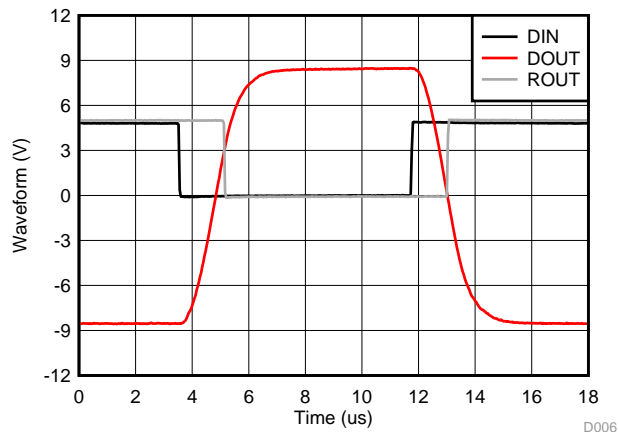

120 kbit/s, 1-nF load

Figure 10. Driver and Receiver Loopback Signal

10 Power Supply Recommendations

The V_{CC} voltage must be connected to the same power source used for logic device connected to DIN and ROUT pins. V_{CC} must be between 4.5 V and 5.5 V.

11 Layout

11.1 Layout Guidelines

Keep the external capacitor traces short. This is more important on C1 and C2 nodes that have the fastest rise and fall times. Make the impedance from TRS202E ground pin and circuit board's ground plane as low as possible for best ESD performance. Use wide metal and multiple vias on both sides of ground pin.

11.2 Layout Example

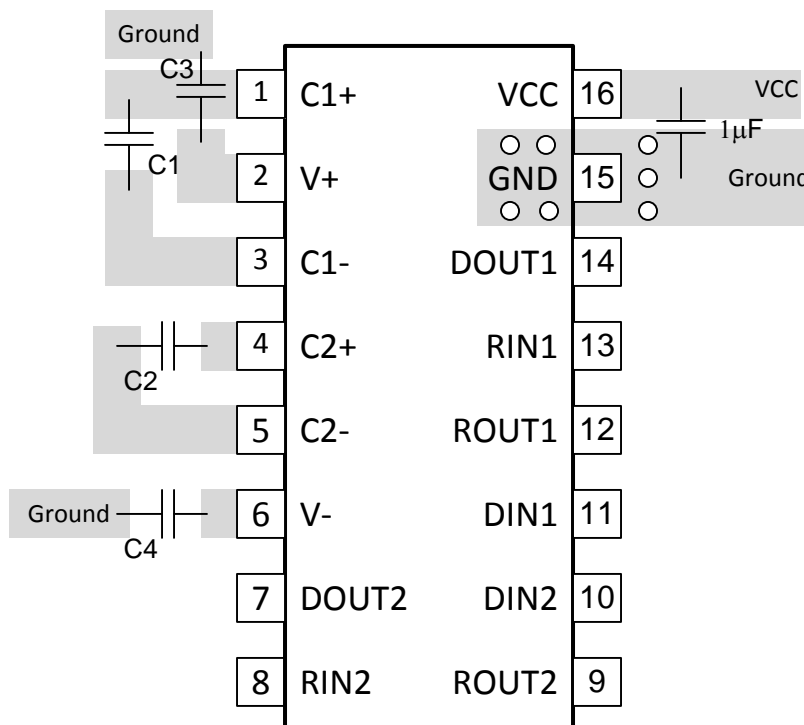

Figure 11. TRS202E Layout

12 Device and Documentation Support

12.1 Receiving Notification of Documentation Updates

To receive notification of documentation updates, navigate to the device product folder on ti.com. In the upper right corner, click on *Alert me* to register and receive a weekly digest of any product information that has changed. For change details, review the revision history included in any revised document.

12.2 Community Resources

The following links connect to TI community resources. Linked contents are provided "AS IS" by the respective contributors. They do not constitute TI specifications and do not necessarily reflect TI's views; see TI's [Terms of Use](#).

TI E2E™ Online Community *TI's Engineer-to-Engineer (E2E) Community*. Created to foster collaboration among engineers. At e2e.ti.com, you can ask questions, share knowledge, explore ideas and help solve problems with fellow engineers.

Design Support *TI's Design Support* Quickly find helpful E2E forums along with design support tools and contact information for technical support.

12.3 Trademarks

E2E is a trademark of Texas Instruments.
All other trademarks are the property of their respective owners.

12.4 Electrostatic Discharge Caution



These devices have limited built-in ESD protection. The leads should be shorted together or the device placed in conductive foam during storage or handling to prevent electrostatic damage to the MOS gates.



12.5 Glossary

[SLYZ022](#) — *TI Glossary*.

This glossary lists and explains terms, acronyms, and definitions.

PACKAGING INFORMATION

Orderable Device	Status (1)	Package Type	Package Drawing	Pins	Package Qty	Eco Plan (2)	Lead/Ball Finish (6)	MSL Peak Temp (3)	Op Temp (°C)	Device Marking (4/5)	Samples
TRS202ECD	ACTIVE	SOIC	D	16	40	Green (RoHS & no Sb/Br)	CU NIPDAU	Level-1-260C-UNLIM	0 to 70	TRS202EC	Samples
TRS202ECDR	ACTIVE	SOIC	D	16	2500	Green (RoHS & no Sb/Br)	CU NIPDAU	Level-1-260C-UNLIM	0 to 70	TRS202EC	Samples
TRS202ECDRG4	ACTIVE	SOIC	D	16	2500	Green (RoHS & no Sb/Br)	CU NIPDAU	Level-1-260C-UNLIM	0 to 70	TRS202EC	Samples
TRS202ECDWR	ACTIVE	SOIC	DW	16	2000	Green (RoHS & no Sb/Br)	CU NIPDAU	Level-1-260C-UNLIM	0 to 70	TRS202EC	Samples
TRS202ECN	ACTIVE	PDIP	N	16	25	Pb-Free (RoHS)	CU NIPDAU	N / A for Pkg Type	0 to 70	TRS202ECN	Samples
TRS202ECNE4	ACTIVE	PDIP	N	16	25	Pb-Free (RoHS)	CU NIPDAU	N / A for Pkg Type	0 to 70	TRS202ECN	Samples
TRS202ECPW	ACTIVE	TSSOP	PW	16	90	Green (RoHS & no Sb/Br)	CU NIPDAU	Level-1-260C-UNLIM	0 to 70	RU02EC	Samples
TRS202ECPWR	ACTIVE	TSSOP	PW	16	2000	Green (RoHS & no Sb/Br)	CU NIPDAU	Level-1-260C-UNLIM	0 to 70	RU02EC	Samples
TRS202ECPWRG4	ACTIVE	TSSOP	PW	16	2000	Green (RoHS & no Sb/Br)	CU NIPDAU	Level-1-260C-UNLIM	0 to 70	RU02EC	Samples
TRS202EID	ACTIVE	SOIC	D	16	40	Green (RoHS & no Sb/Br)	CU NIPDAU	Level-1-260C-UNLIM	-40 to 85	TRS202EI	Samples
TRS202EIDR	ACTIVE	SOIC	D	16	2500	Green (RoHS & no Sb/Br)	CU NIPDAU	Level-1-260C-UNLIM	-40 to 85	TRS202EI	Samples
TRS202EIDW	ACTIVE	SOIC	DW	16	40	Green (RoHS & no Sb/Br)	CU NIPDAU	Level-1-260C-UNLIM	-40 to 85	TRS202EI	Samples
TRS202EIDWR	ACTIVE	SOIC	DW	16	2000	Green (RoHS & no Sb/Br)	CU NIPDAU	Level-1-260C-UNLIM	-40 to 85	TRS202EI	Samples
TRS202EIN	ACTIVE	PDIP	N	16	25	Pb-Free (RoHS)	CU NIPDAU	N / A for Pkg Type	-40 to 85	TRS202EIN	Samples
TRS202EINE4	ACTIVE	PDIP	N	16	25	Pb-Free (RoHS)	CU NIPDAU	N / A for Pkg Type	-40 to 85	TRS202EIN	Samples
TRS202EIPW	ACTIVE	TSSOP	PW	16	90	Green (RoHS & no Sb/Br)	CU NIPDAU	Level-1-260C-UNLIM	-40 to 85	RU02EI	Samples
TRS202EIPWG4	ACTIVE	TSSOP	PW	16	90	Green (RoHS & no Sb/Br)	CU NIPDAU	Level-1-260C-UNLIM	-40 to 85	RU02EI	Samples

Orderable Device	Status (1)	Package Type	Package Drawing	Pins	Package Qty	Eco Plan (2)	Lead/Ball Finish (6)	MSL Peak Temp (3)	Op Temp (°C)	Device Marking (4/5)	Samples
TRS202EIPWR	ACTIVE	TSSOP	PW	16	2000	Green (RoHS & no Sb/Br)	CU NIPDAU	Level-1-260C-UNLIM	-40 to 85	RU02EI	
TRS202EIPWRG4	ACTIVE	TSSOP	PW	16	2000	Green (RoHS & no Sb/Br)	CU NIPDAU	Level-1-260C-UNLIM	-40 to 85	RU02EI	

(1) The marketing status values are defined as follows:

ACTIVE: Product device recommended for new designs.

LIFEBUY: TI has announced that the device will be discontinued, and a lifetime-buy period is in effect.

NRND: Not recommended for new designs. Device is in production to support existing customers, but TI does not recommend using this part in a new design.

PREVIEW: Device has been announced but is not in production. Samples may or may not be available.

OBSOLETE: TI has discontinued the production of the device.

(2) Eco Plan - The planned eco-friendly classification: Pb-Free (RoHS), Pb-Free (RoHS Exempt), or Green (RoHS & no Sb/Br) - please check <http://www.ti.com/productcontent> for the latest availability information and additional product content details.

TBD: The Pb-Free/Green conversion plan has not been defined.

Pb-Free (RoHS): TI's terms "Lead-Free" or "Pb-Free" mean semiconductor products that are compatible with the current RoHS requirements for all 6 substances, including the requirement that lead not exceed 0.1% by weight in homogeneous materials. Where designed to be soldered at high temperatures, TI Pb-Free products are suitable for use in specified lead-free processes.

Pb-Free (RoHS Exempt): This component has a RoHS exemption for either 1) lead-based flip-chip solder bumps used between the die and package, or 2) lead-based die adhesive used between the die and leadframe. The component is otherwise considered Pb-Free (RoHS compatible) as defined above.

Green (RoHS & no Sb/Br): TI defines "Green" to mean Pb-Free (RoHS compatible), and free of Bromine (Br) and Antimony (Sb) based flame retardants (Br or Sb do not exceed 0.1% by weight in homogeneous material)

(3) MSL, Peak Temp. - The Moisture Sensitivity Level rating according to the JEDEC industry standard classifications, and peak solder temperature.

(4) There may be additional marking, which relates to the logo, the lot trace code information, or the environmental category on the device.

(5) Multiple Device Markings will be inside parentheses. Only one Device Marking contained in parentheses and separated by a "~" will appear on a device. If a line is indented then it is a continuation of the previous line and the two combined represent the entire Device Marking for that device.

(6) Lead/Ball Finish - Orderable Devices may have multiple material finish options. Finish options are separated by a vertical ruled line. Lead/Ball Finish values may wrap to two lines if the finish value exceeds the maximum column width.

Important Information and Disclaimer: The information provided on this page represents TI's knowledge and belief as of the date that it is provided. TI bases its knowledge and belief on information provided by third parties, and makes no representation or warranty as to the accuracy of such information. Efforts are underway to better integrate information from third parties. TI has taken and continues to take reasonable steps to provide representative and accurate information but may not have conducted destructive testing or chemical analysis on incoming materials and chemicals. TI and TI suppliers consider certain information to be proprietary, and thus CAS numbers and other limited information may not be available for release.

In no event shall TI's liability arising out of such information exceed the total purchase price of the TI part(s) at issue in this document sold by TI to Customer on an annual basis.

TAPE AND REEL INFORMATION

QUADRANT ASSIGNMENTS FOR PIN 1 ORIENTATION IN TAPE

*All dimensions are nominal

Device	Package Type	Package Drawing	Pins	SPQ	Reel Diameter (mm)	Reel Width W1 (mm)	A0 (mm)	B0 (mm)	K0 (mm)	P1 (mm)	W (mm)	Pin1 Quadrant
TRS202ECDR	SOIC	D	16	2500	330.0	16.4	6.5	10.3	2.1	8.0	16.0	Q1
TRS202ECDWR	SOIC	DW	16	2000	330.0	16.4	10.75	10.7	2.7	12.0	16.0	Q1
TRS202ECPWR	TSSOP	PW	16	2000	330.0	12.4	6.9	5.6	1.6	8.0	12.0	Q1
TRS202EIDR	SOIC	D	16	2500	330.0	16.4	6.5	10.3	2.1	8.0	16.0	Q1
TRS202EIDWR	SOIC	DW	16	2000	330.0	16.4	10.75	10.7	2.7	12.0	16.0	Q1
TRS202EIPWR	TSSOP	PW	16	2000	330.0	12.4	6.9	5.6	1.6	8.0	12.0	Q1

TAPE AND REEL BOX DIMENSIONS

*All dimensions are nominal

Device	Package Type	Package Drawing	Pins	SPQ	Length (mm)	Width (mm)	Height (mm)
TRS202ECDR	SOIC	D	16	2500	367.0	367.0	38.0
TRS202ECDWR	SOIC	DW	16	2000	367.0	367.0	38.0
TRS202ECPWR	TSSOP	PW	16	2000	367.0	367.0	35.0
TRS202EIDR	SOIC	D	16	2500	367.0	367.0	38.0
TRS202EIDWR	SOIC	DW	16	2000	367.0	367.0	38.0
TRS202EIPWR	TSSOP	PW	16	2000	367.0	367.0	35.0

D (R-PDSO-G16)

PLASTIC SMALL OUTLINE



- NOTES:
- A. All linear dimensions are in inches (millimeters).
 - B. This drawing is subject to change without notice.
 - $\triangle C$ Body length does not include mold flash, protrusions, or gate burrs. Mold flash, protrusions, or gate burrs shall not exceed 0.006 (0,15) each side.
 - $\triangle D$ Body width does not include interlead flash. Interlead flash shall not exceed 0.017 (0,43) each side.
 - E. Reference JEDEC MS-012 variation AC.

D (R-PDSO-G16)

PLASTIC SMALL OUTLINE



- NOTES:
- A. All linear dimensions are in millimeters.
 - B. This drawing is subject to change without notice.
 - C. Publication IPC-7351 is recommended for alternate designs.
 - D. Laser cutting apertures with trapezoidal walls and also rounding corners will offer better paste release. Customers should contact their board assembly site for stencil design recommendations. Refer to IPC-7525 for other stencil recommendations.
 - E. Customers should contact their board fabrication site for solder mask tolerances between and around signal pads.

PW (R-PDSO-G16)

PLASTIC SMALL OUTLINE



4040064-4/G 02/11

- NOTES:
- A. All linear dimensions are in millimeters. Dimensioning and tolerancing per ASME Y14.5M-1994.
 - B. This drawing is subject to change without notice.
 - C. Body length does not include mold flash, protrusions, or gate burrs. Mold flash, protrusions, or gate burrs shall not exceed 0,15 each side.
 - D. Body width does not include interlead flash. Interlead flash shall not exceed 0,25 each side.
 - E. Falls within JEDEC MO-153

PW (R-PDSO-G16)

PLASTIC SMALL OUTLINE



- NOTES:
- All linear dimensions are in millimeters.
 - This drawing is subject to change without notice.
 - Publication IPC-7351 is recommended for alternate designs.
 - Laser cutting apertures with trapezoidal walls and also rounding corners will offer better paste release. Customers should contact their board assembly site for stencil design recommendations. Refer to IPC-7525 for other stencil recommendations.
 - Customers should contact their board fabrication site for solder mask tolerances between and around signal pads.

GENERIC PACKAGE VIEW

DW 16

SOIC - 2.65 mm max height

SMALL OUTLINE INTEGRATED CIRCUIT

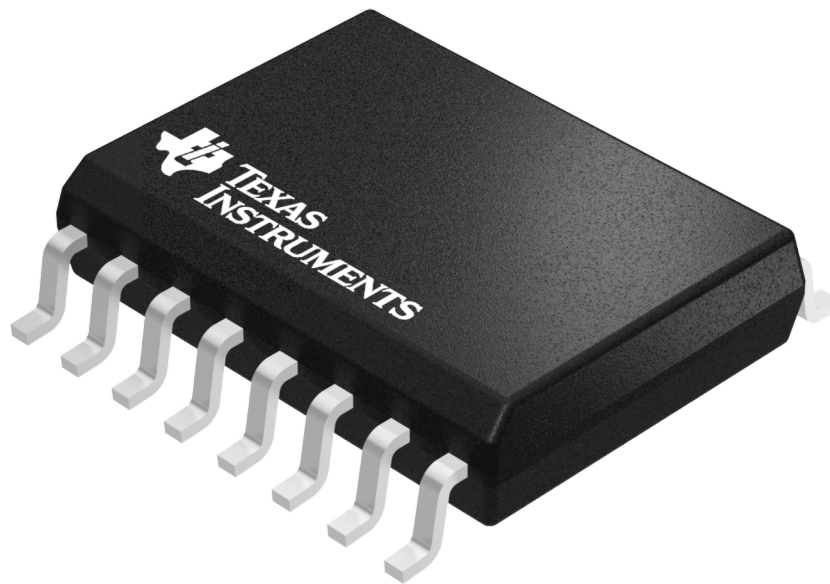

Images above are just a representation of the package family, actual package may vary.
Refer to the product data sheet for package details.

4040000-2/H



DW0016A

PACKAGE OUTLINE SOIC - 2.65 mm max height

SOIC



4220721/A 07/2016

NOTES:

1. All linear dimensions are in millimeters. Dimensions in parenthesis are for reference only. Dimensioning and tolerancing per ASME Y14.5M.
2. This drawing is subject to change without notice.
3. This dimension does not include mold flash, protrusions, or gate burrs. Mold flash, protrusions, or gate burrs shall not exceed 0.15 mm, per side.
4. This dimension does not include interlead flash. Interlead flash shall not exceed 0.25 mm, per side.
5. Reference JEDEC registration MS-013.

EXAMPLE BOARD LAYOUT

DW0016A

SOIC - 2.65 mm max height

SOIC



LAND PATTERN EXAMPLE
SCALE:7X



SOLDER MASK DETAILS

4220721/A 07/2016

NOTES: (continued)

6. Publication IPC-7351 may have alternate designs.

7. Solder mask tolerances between and around signal pads can vary based on board fabrication site.

EXAMPLE STENCIL DESIGN

DW0016A

SOIC - 2.65 mm max height

SOIC



SOLDER PASTE EXAMPLE
BASED ON 0.125 mm THICK STENCIL
SCALE:7X

4220721/A 07/2016

NOTES: (continued)

8. Laser cutting apertures with trapezoidal walls and rounded corners may offer better paste release. IPC-7525 may have alternate design recommendations.
9. Board assembly site may have different recommendations for stencil design.

N (R-PDIP-T**)

PLASTIC DUAL-IN-LINE PACKAGE

16 PINS SHOWN



- NOTES:
- A. All linear dimensions are in inches (millimeters).
 - B. This drawing is subject to change without notice.
 - Falls within JEDEC MS-001, except 18 and 20 pin minimum body length (Dim A).
 - The 20 pin end lead shoulder width is a vendor option, either half or full width.

IMPORTANT NOTICE

Texas Instruments Incorporated (TI) reserves the right to make corrections, enhancements, improvements and other changes to its semiconductor products and services per JESD46, latest issue, and to discontinue any product or service per JESD48, latest issue. Buyers should obtain the latest relevant information before placing orders and should verify that such information is current and complete.

TI's published terms of sale for semiconductor products (<http://www.ti.com/sc/docs/stdterms.htm>) apply to the sale of packaged integrated circuit products that TI has qualified and released to market. Additional terms may apply to the use or sale of other types of TI products and services.

Reproduction of significant portions of TI information in TI data sheets is permissible only if reproduction is without alteration and is accompanied by all associated warranties, conditions, limitations, and notices. TI is not responsible or liable for such reproduced documentation. Information of third parties may be subject to additional restrictions. Resale of TI products or services with statements different from or beyond the parameters stated by TI for that product or service voids all express and any implied warranties for the associated TI product or service and is an unfair and deceptive business practice. TI is not responsible or liable for any such statements.

Buyers and others who are developing systems that incorporate TI products (collectively, "Designers") understand and agree that Designers remain responsible for using their independent analysis, evaluation and judgment in designing their applications and that Designers have full and exclusive responsibility to assure the safety of Designers' applications and compliance of their applications (and of all TI products used in or for Designers' applications) with all applicable regulations, laws and other applicable requirements. Designer represents that, with respect to their applications, Designer has all the necessary expertise to create and implement safeguards that (1) anticipate dangerous consequences of failures, (2) monitor failures and their consequences, and (3) lessen the likelihood of failures that might cause harm and take appropriate actions. Designer agrees that prior to using or distributing any applications that include TI products, Designer will thoroughly test such applications and the functionality of such TI products as used in such applications.

TI's provision of technical, application or other design advice, quality characterization, reliability data or other services or information, including, but not limited to, reference designs and materials relating to evaluation modules, (collectively, "TI Resources") are intended to assist designers who are developing applications that incorporate TI products; by downloading, accessing or using TI Resources in any way, Designer (individually or, if Designer is acting on behalf of a company, Designer's company) agrees to use any particular TI Resource solely for this purpose and subject to the terms of this Notice.

TI's provision of TI Resources does not expand or otherwise alter TI's applicable published warranties or warranty disclaimers for TI products, and no additional obligations or liabilities arise from TI providing such TI Resources. TI reserves the right to make corrections, enhancements, improvements and other changes to its TI Resources. TI has not conducted any testing other than that specifically described in the published documentation for a particular TI Resource.

Designer is authorized to use, copy and modify any individual TI Resource only in connection with the development of applications that include the TI product(s) identified in such TI Resource. NO OTHER LICENSE, EXPRESS OR IMPLIED, BY ESTOPPEL OR OTHERWISE TO ANY OTHER TI INTELLECTUAL PROPERTY RIGHT, AND NO LICENSE TO ANY TECHNOLOGY OR INTELLECTUAL PROPERTY RIGHT OF TI OR ANY THIRD PARTY IS GRANTED HEREIN, including but not limited to any patent right, copyright, mask work right, or other intellectual property right relating to any combination, machine, or process in which TI products or services are used. Information regarding or referencing third-party products or services does not constitute a license to use such products or services, or a warranty or endorsement thereof. Use of TI Resources may require a license from a third party under the patents or other intellectual property of the third party, or a license from TI under the patents or other intellectual property of TI.

TI RESOURCES ARE PROVIDED "AS IS" AND WITH ALL FAULTS. TI DISCLAIMS ALL OTHER WARRANTIES OR REPRESENTATIONS, EXPRESS OR IMPLIED, REGARDING RESOURCES OR USE THEREOF, INCLUDING BUT NOT LIMITED TO ACCURACY OR COMPLETENESS, TITLE, ANY EPIDEMIC FAILURE WARRANTY AND ANY IMPLIED WARRANTIES OF MERCHANTABILITY, FITNESS FOR A PARTICULAR PURPOSE, AND NON-INFRINGEMENT OF ANY THIRD PARTY INTELLECTUAL PROPERTY RIGHTS. TI SHALL NOT BE LIABLE FOR AND SHALL NOT DEFEND OR INDEMNIFY DESIGNER AGAINST ANY CLAIM, INCLUDING BUT NOT LIMITED TO ANY INFRINGEMENT CLAIM THAT RELATES TO OR IS BASED ON ANY COMBINATION OF PRODUCTS EVEN IF DESCRIBED IN TI RESOURCES OR OTHERWISE. IN NO EVENT SHALL TI BE LIABLE FOR ANY ACTUAL, DIRECT, SPECIAL, COLLATERAL, INDIRECT, PUNITIVE, INCIDENTAL, CONSEQUENTIAL OR EXEMPLARY DAMAGES IN CONNECTION WITH OR ARISING OUT OF TI RESOURCES OR USE THEREOF, AND REGARDLESS OF WHETHER TI HAS BEEN ADVISED OF THE POSSIBILITY OF SUCH DAMAGES.

Unless TI has explicitly designated an individual product as meeting the requirements of a particular industry standard (e.g., ISO/TS 16949 and ISO 26262), TI is not responsible for any failure to meet such industry standard requirements.

Where TI specifically promotes products as facilitating functional safety or as compliant with industry functional safety standards, such products are intended to help enable customers to design and create their own applications that meet applicable functional safety standards and requirements. Using products in an application does not by itself establish any safety features in the application. Designers must ensure compliance with safety-related requirements and standards applicable to their applications. Designer may not use any TI products in life-critical medical equipment unless authorized officers of the parties have executed a special contract specifically governing such use. Life-critical medical equipment is medical equipment where failure of such equipment would cause serious bodily injury or death (e.g., life support, pacemakers, defibrillators, heart pumps, neurostimulators, and implantables). Such equipment includes, without limitation, all medical devices identified by the U.S. Food and Drug Administration as Class III devices and equivalent classifications outside the U.S.

TI may expressly designate certain products as completing a particular qualification (e.g., Q100, Military Grade, or Enhanced Product). Designers agree that it has the necessary expertise to select the product with the appropriate qualification designation for their applications and that proper product selection is at Designers' own risk. Designers are solely responsible for compliance with all legal and regulatory requirements in connection with such selection.

Designer will fully indemnify TI and its representatives against any damages, costs, losses, and/or liabilities arising out of Designer's non-compliance with the terms and provisions of this Notice.