

High Performance Power Factor Preregulator

FEATURES

- Controls Boost PWM to Near Unity Power Factor
- Fixed Frequency Average Current Mode Control Minimizes Line Current Distortion
- Built-in Active Snubber (ZVT) allows Operation to 500kHz, improved EMI and Efficiency
- Inductor Current Synthesizer allows Single Current Transformer Current Sense for Improved Efficiency and Noise Margin
- Accurate Analog Multiplier with Line Compensator allows for Universal Input Voltage Operation
- High Bandwidth (5MHz), Low Offset Current Amplifier
- Overvoltage and Overcurrent protection
- Two UVLO Threshold Options
- 150µA Startup Supply Current Typical
- Precision 1% 7.5V Reference

DESCRIPTION

The UC3855A/B provides all the control features necessary for high power, high frequency PFC boost converters. The average current mode control method allows for stable, low distortion AC line current programming without the need for slope compensation. In addition, the UC3855 utilizes an active snubbing or ZVT (Zero Voltage Transition technique) to dramatically reduce diode recovery and MOSFET turn-on losses, resulting in lower EMI emissions and higher efficiency. Boost converter switching frequencies up to 500kHz are now realizable, requiring only an additional small MOSFET, diode, and inductor to resonantly soft switch the boost diode and switch. Average current sensing can be employed using a simple resistive shunt or a current sense transformer. Using the current sense transformer method, the internal current synthesizer circuit buffers the inductor current during the switch on-time, and reconstructs the inductor current during the switch off-time. Improved signal to noise ratio and negligible current sensing losses make this an attractive solution for higher power applications.

The UC3855A/B also features a single quadrant multiplier, squarer, and divider circuit which provides the programming signal for the current loop. The internal multiplier current limit reduces output power during low line conditions. An overvoltage protection circuit disables both controller outputs in the event of a boost output OV condition.

Low startup supply current, UVLO with hysteresis, a 1% 7.5V reference, voltage amplifier with softstart, input supply voltage clamp, enable comparator, and overcurrent comparator complete the list of features. Available packages include: 20 pin N, DW, Q, J, and L.

BLOCK DIAGRAM

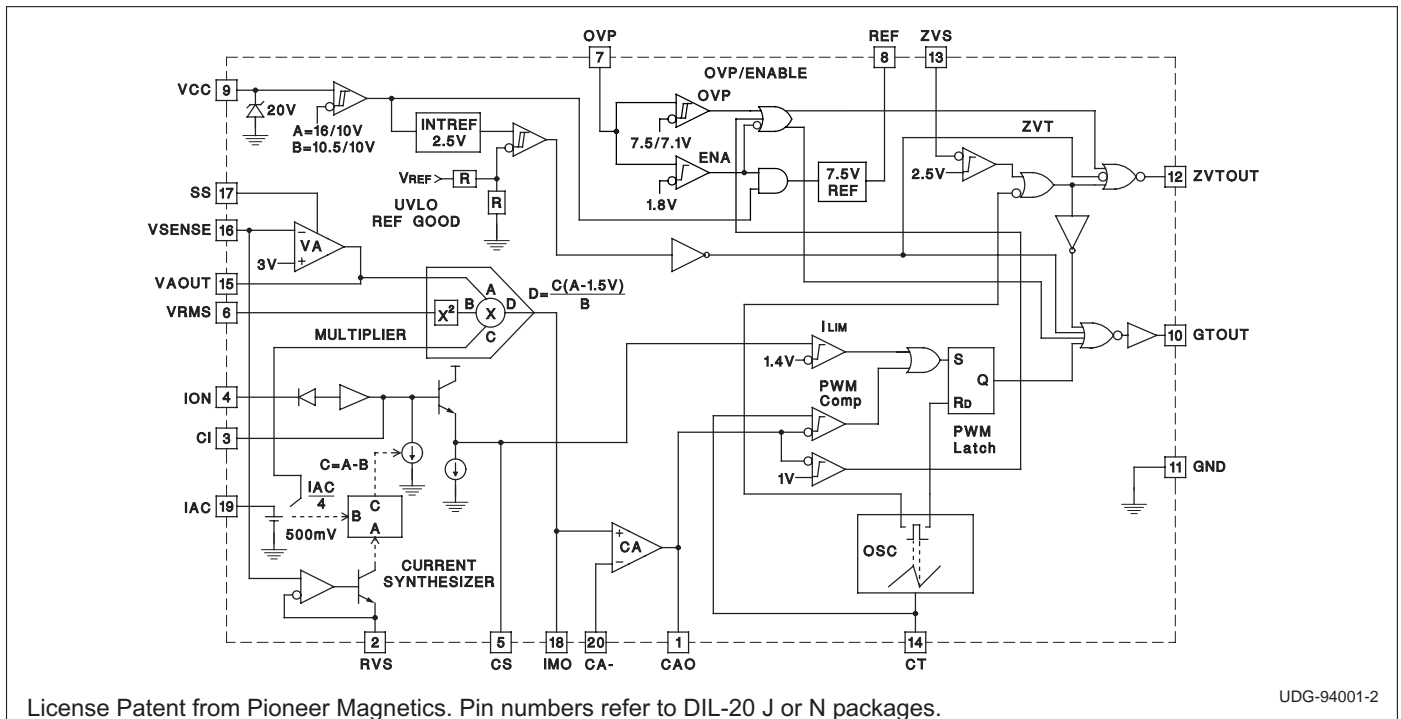

UDG-94001-2

ABSOLUTE MAXIMUM RATINGS

| | |
|---------------------------------------|--------------------|
| Supply Voltage VCC | Internally Limited |
| VCC Supply Clamp Current | 20mA |
| PFC Gate Driver Current (continuous) | ± 0.5A |
| PFC Gate Driver Current (peak) | ± 1.5A |
| ZVT Drive Current (continuous) | ± 0.25A |
| ZVT Drive Current (peak) | ± 0.75A |
| Input Current (IAC, RT, RVA) | 5mA |
| Analog Inputs (except Peak Limit) | -0.3 to 10V |
| Peak Limit Input | -0.3 to 6.5V |
| Softstart Sinking Current | 1.5mA |
| Storage Temperature | -65°C to +150°C |
| Junction Temperature | -55°C to +150°C |
| Lead Temperature (Soldering, 10 sec.) | +300°C |

Currents are positive into, negative out of the specified terminal. Consult Packaging Section of Databook for thermal limitations and considerations of packages. All voltages are referenced to GND.

CONNECTION DIAGRAMS

PLCC-20 & LCC-20 (Top View)
Q or L Package

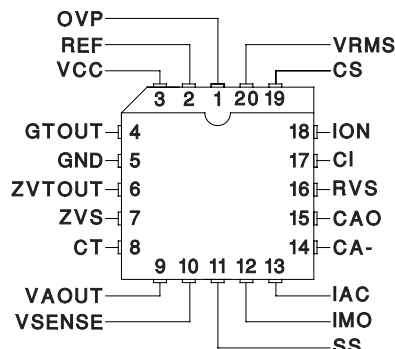

DIL-20 (Top View)
J or N Package

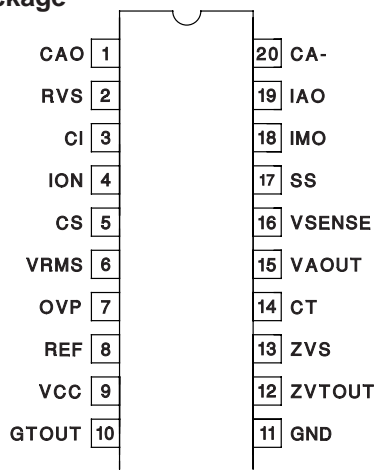

SOIC-20 (Top View)
DW Package

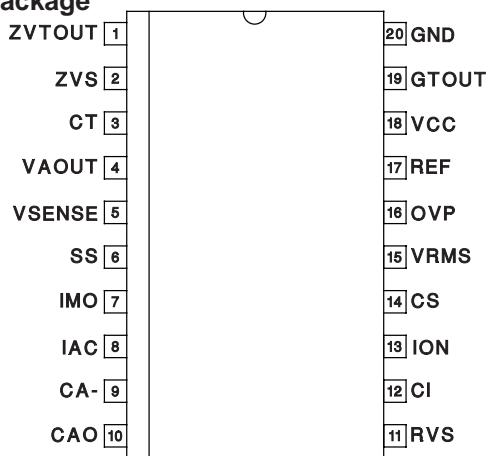

ELECTRICAL CHARACTERISTICS: Unless otherwise specified: VCC = 18V, RVS = 23k, CT = 470pF, CI = 150pF, VRMS = 1.5V, IAC = 100μA, ISENSE = 0V, CAO = 4V, VAOUT = 3.5V, VSENSE = 3V. -40°C to 85°C (UC2855A/B), 0°C to 70°C (UC3855A/B).

| PARAMETER | TEST CONDITIONS | MIN | TYP | MAX | UNITS |
|------------------------------|-----------------------------------|------|------|------|-------|
| Overall | | | | | |
| Supply Current, OFF | CAO, VAOUT = 0V, VCC = UVLO -0.3V | | 150 | 500 | μA |
| Supply Current, OPERATING | | | 17 | 25 | mA |
| VCC Turn-On Threshold | UC3855A | | 15.5 | 17.5 | V |
| VCCTurn-Off Threshold | UC3855A,B | 9 | 10 | | V |
| VCC Turn-On Threshold | UC3855B | | 10.5 | 10.8 | V |
| VCC Clamp | I(VCC) = ICC(on) + 5mA | 18 | 20 | 22 | V |
| Voltage Amplifier | | | | | |
| Input Voltage | | 2.9 | | 3.1 | V |
| VSENSE Bias Current | | -500 | 25 | 500 | nA |
| Open Loop Gain | VOUT = 2 to 5V | 65 | 80 | | dB |
| VOUT High | ILOAD = -300μA | 5.75 | 6 | 6.25 | V |
| VOUT Low | ILOAD = 300μA | | 0.3 | 0.5 | V |
| Output Short Circuit Current | VOUT = 0V | | 0.6 | 3 | mA |

ELECTRICAL CHARACTERISTICS: Unless otherwise specified: VCC = 18V, RVS = 23k, CT = 470pF, CI = 150pF, VRMS = 1.5V, IAC = 100μA, ISENSE = 0V, CAO = 4V, VAOUT = 3.5V, VSENSE = 3V. -40°C to 85°C (UC2855A/B), 0°C to 70°C (UC3855A/B).

| PARAMETER | TEST CONDITIONS | MIN | TYP | MAX | UNITS |
|---------------------------------|--|-------|-------|-------|-------|
| Current Amplifier | | | | | |
| Input Offset Voltage | V _{CM} = -2.5V | -4 | | 4 | mV |
| Input Bias Current (Sense) | V _{CM} = 2.5V | -500 | | 500 | nA |
| Open Loop Gain | V _{CM} = 2.5V, V _{OUT} = 2 to 6V | 80 | 110 | | dB |
| V _{OUT} High | I _{LOAD} = -500μA | | 6 | | V |
| V _{OUT} Low | I _{LOAD} = 500μA | | 0.3 | 0.5 | V |
| Output Short Circuit Current | V _{OUT} = 0V | | 1 | 3 | mA |
| Common Mode Range | | -0.3 | | 5 | V |
| Gain Bandwidth Product | F _{IN} = 100kHz, 10mV, P-P, T _A = 25°C | 2.5 | 5 | | MHz |
| Reference | | | | | |
| Output Voltage | I _{REF} = 0mA, T _A = 25°C | 7.388 | 7.5 | 7.613 | V |
| | I _{REF} = 0mA | 7.313 | 7.5 | 7.688 | V |
| Load Regulation | I _{REF} = 1 to 10 mA | -15 | | 15 | mV |
| Line Regulation | V _{CC} = 15 to 35V | -10 | | 10 | mV |
| Short Circuit Current | REF = 0V | 20 | 45 | 65 | mA |
| Oscillator | | | | | |
| Initial Accuracy | T _A = 25°C | 170 | 200 | 230 | kHz |
| Voltage Stability | V _{CC} = 12 to 18V | | 1 | | % |
| Total Variation | Line, Temp. | 160 | | 240 | kHz |
| Ramp Amplitude (P-P) | Outputs at 0% duty cycle | 4.7 | | 5.7 | V |
| Ramp Valley Voltage | | 1.1 | | 1.6 | V |
| Enable/OVP/Current Limit | | | | | |
| Enable Threshold | | | 1.8 | 2.2 | V |
| OVP Threshold | | | 7.5 | 7.66 | V |
| OVP Hysteresis | | 200 | 400 | 600 | mV |
| OVP Propagation Delay | | | 200 | | ns |
| OVP Input Bias Current | V = 7.5V | | 1 | 10 | μA |
| PKLIMIT Threshold | | 1.25 | 1.5 | 1.75 | V |
| PKLIMIT Input Current | V _{PKLIMIT} = 1.5V | | 100 | | μA |
| PKLIMIT Prop. Delay | | | 100 | | ns |
| Soft Start | | | | | |
| Soft Start Charge Current | | -10 | -13 | -20 | μA |
| Soft Start Discharge Current | | 2 | 10 | 20 | mA |
| Multiplier | | | | | |
| Output Current - IAC Limited | IAC = 100μA, VRMS = 1V | -235 | -205 | -175 | μA |
| Output Current - Zero | IAC = 0μA | -2 | -0.2 | 2 | μA |
| Output Current - Power Limited | VRMS = 1.5V, VAOUT = 5.5V | -250 | -209 | -160 | μA |
| Output Current | VRMS = 1.5V, VAOUT = 2V | | -26 | | μA |
| | VRMS = 1.5V VAOUT = 5V | | -190 | | μA |
| | VRMS = 5V, VAOUT = 2V | | -3 | | μA |
| | VRMS = 5V, VAOUT = 5V | | -17 | | μA |
| Gain Constant | Refer to Note 1 | -0.95 | -0.85 | -0.75 | 1/V |

ELECTRICAL CHARACTERISTICS: Unless otherwise specified: VCC = 18V, RVS = 23k, CT = 470pF, CI = 150pF, VRMS = 1.5V, IAC = 100μA, ISENSE = 0V, CAO = 4V, VAOUT = 3.5V, VSENSE = 3V. -40°C to 85°C (UC2855A/B), 0°C to 70°C (UC3855A/B).

| PARAMETER | TEST CONDITIONS | MIN | TYP | MAX | UNITS |
|------------------------------------|--------------------------------------|------|------|------|-------|
| Gate Driver Output | | | | | |
| Output High Voltage | I _{OUT} = -200mA, VCC = 15V | 12 | 12.8 | | V |
| Output Low Voltage | I _{OUT} = 200mA | | 1 | 2.2 | V |
| Output Low Voltage | I _{OUT} = 10mA | | 300 | 500 | mV |
| Output Low (UVLO) | I _{OUT} = 50mA, VCC = 0V | | 0.9 | 1.5 | V |
| Output RISE/FALL Time | C _{LOAD} = 1nF | | 35 | | ns |
| Output Peak Current | C _{LOAD} = 10nF | 0.5 | 1.5 | | A |
| ZVT | | | | | |
| ZVS Threshold | | 2.3 | 2.6 | 2.9 | V |
| Input Bias Current | V = 2.5V, V _{CT} = 0 | | 6 | 20 | μA |
| Propagation Delay | Measured at ZVTOUT | | 100 | | ns |
| Maximum Pulse Width | | | 400 | | ns |
| Output High Voltage | I _{OUT} = -100mA, VCC = 15V | 12 | 12.8 | | V |
| Output Low Voltage | I _{OUT} = 100mA | | 1 | 2.2 | V |
| Output Low Voltage | I _{OUT} = 10mA | | 300 | 900 | mV |
| Output Low (UVLO) | I _{OUT} = 50mA, VCC = 0V | | 0.9 | 1.5 | V |
| Output RISE/FALL Time | C _{LOAD} = 1nF | | 35 | | ns |
| Output Peak Current | C _{LOAD} = 10nF | 0.25 | 0.75 | | A |
| Current Synthesizer | | | | | |
| I _{ON} to CS Offset | V _{ION} = 0V | | 30 | 50 | mV |
| CI Discharge Current | IAC = 50μA | 105 | 118 | 140 | μA |
| | IAC = 500μA | | 5 | | μA |
| IAC Offset Voltage | | 0.3 | 0.65 | 1.1 | V |
| I _{ON} Buffer Slew Rate | | | 10 | | V/μs |
| I _{ON} Input Bias Current | V _{ION} = 2V | | 2 | 15 | μA |
| RVS Output Voltage | 23k from RVS to GND | 2.87 | 3 | 3.13 | V |

Note 1: Gain constant (K) = $\frac{IAC \cdot (VA_{OUT} - 1.5V)}{(V_{RMS}^2 \cdot IMO)}$ at V_{RMS} = 1.5V, VA_{OUT} = 5.5V.

PIN DESCRIPTIONS

CA This is the inverting input to the current amplifier. Connect the required compensation components between this pin and CAOUT. The common mode operating range for this input is between -0.3V and 5V.

CAO: This is the output of the wide bandwidth current amplifier and one of the inputs to the PWM duty cycle comparator. The output signal generated by this amplifier commands the PWM to force the correct input current. The output can swing from 0.1V to 7.5V.

CI: The level shifted current sense signal is impressed upon a capacitor connected between this pin and GND. The buffered current sense transformer signal charges the capacitor when the boost switch is on. When the switch is off, the current synthesizer discharges the capacitor at a rate proportional to the di/dt of the boost inductor current. In this way, the discharge current is approximately equal to

$$\frac{3V}{RRVS} - \frac{IAC}{4}$$

Discharging the CI capacitor in this fashion, a “reconstructed” version of the inductor current is generated using only one current sense transformer.

PIN DESCRIPTIONS (cont.)

CS: The reconstructed inductor current waveform generated on the CI pin is level shifted down a diode drop to this pin. Connect the current amplifier input resistor between CS and the inverting input of the current amplifier. The waveform on this pin is compared to the multiplier output waveform through the average current sensing current amplifier. The input to the peak current limiting comparator is also connected to this pin. A voltage level greater than 1.5 volts on this pin will trip the comparator and disable the gate driver output.

CT: A capacitor from CT to GND sets the PWM oscillator frequency according to the following equation:

$$f \approx \frac{1}{11200 \bullet CT}$$

Use a high quality ceramic capacitor with low ESL and ESR for best results. A minimum CT value of 200pF insures good accuracy and less susceptibility to circuit layout parasitics. The oscillator and PWM are designed to provide practical operation to 500kHz.

GND: All voltages are measured with respect to this pin. All bypass and timing capacitors connected to GND should have leads as short and direct as possible.

GTOUT: The output of the PWM is a 1.5A peak totem pole MOSFET gate driver on GTOUT. A series resistor between GTOUT and the MOSFET gate of at least 10 ohms should be used to limit the overshoot on GTOUT. In addition, a low Vf Schottky diode should be connected between GTOUT and GND to limit undershoot and possible erratic operation.

IAC: This is a current input to the multiplier. The current into this pin should correspond to the instantaneous value of the rectified AC input line voltage. This is accomplished by connecting a resistor directly between IAC and the rectified input line voltage. The nominal 650mV level present on IAC negates the need for any additional compensating resistors to accommodate for the zero crossings of the line. A current equal to one fourth of the IAC current forms one of the inductor current synthesizer inputs.

IMO: This is the output of the multiplier, and the non-inverting input of the current amplifier. Since this output is a current, connect a resistor between this pin and ground equal in value to the input resistor of the current amplifier. The common mode operating range for this pin is -0.3V to 5V.

ION: This pin is the current sensing input. It should be connected to the secondary side output of a current sensing transformer whose primary winding is in series with the boost switch. The resultant signal applied to this input is buffered and level shifted up a diode to the CI capacitor on the CI pin. The ION buffer has a source only output. Discharge of the CI cap is enabled through the current synthesizer circuitry. The current sense transformer termination resistor should be designed to obtain a 1V input signal amplitude at peak switch current.

OVP: This pin senses the boost output voltage through a voltage divider. The enable comparator input is TTL compatible and can be used as a remote shutdown port. A voltage level below 1.8V, disables VREF, oscillator, and the PWM circuitry via the enable comparator. Between 1.8V and VREF (7.5V) the UC is enabled. Voltage levels above 7.5V will set the PWM latch via the hysteretic OVP comparator and disable both ZVTOUT and GTOUT until the OVP level has decayed by the nominal hysteresis of 400mV. If the voltage divider is designed to initiate an OVP fault at 5% of OV, the internal hysteresis enables normal operation again when the output voltage has reached its nominal regulation level. Both the OVP and enable comparators have direct logical connections to the PWM output and exhibit typical propagation delays of 200ns.

REF: REF is the output of the precision reference. The output is capable of supplying 25mA to peripheral circuitry and is internally short circuit current limited. REF is disabled and low whenever VCC is below the UVLO threshold, and when OVP is below 1.8V. A REF "GOOD" comparator senses REF and disables the stage until REF has attained approximately 90% of its nominal value. Bypass REF to GND with a 0.1μF or larger ceramic capacitor for best stability.

RVS: The nominal 3V signal present on the VSENSE pin is buffered and brought out to the RVS pin. A current proportional to the output voltage is generated by connecting a resistor between this pin and GND. This current forms the second input to the current synthesizer.

SS: Soft-start V_{SS} is discharged for V_{VCC} low conditions. When enabled, SS charges an external capacitor with a current source. This voltage is used as the voltage error signal during start-up, enabling the PWM duty cycle to increase slowly. In the event of a V_{VCC} dropout, the OVP/EN is forced below 1.8V (typ), SS quickly discharges to disable the PWM.

PIN DESCRIPTIONS (cont.)

VAO: This is the output of the voltage amplifier. At a given input RMS voltage, the voltage on this pin will vary directly with the output load. The output swing is limited from approximately 100mV to 6V. Voltage levels below 1.5V on this pin will inhibit the multiplier output.

VCC: Positive supply rail for the IC. Bypass this pin to GND with a 1 μ F low ESL, ESR ceramic capacitor. This pin is internally clamped to 20V. Current into this clamp should be limited to less than 10mA. The UC3855A has a 15.5V (nominal) turn on threshold with 6 volts of hysteresis while the UC3855B turns on at 10.5V with 500mV of hysteresis.

VRMS: This pin is the feedforward line voltage compensation input to the multiplier. A voltage on VRMS proportional to the AC input RMS voltage commands the multiplier to alter the current command signal by $1/VRMS^2$ to maintain a constant power balance. The input to VRMS is generally derived from a two pole low pass filter/voltage divider connected to the rectified AC input voltage. This feature allows universal input supply voltage operation and faster response to input line fluctuations for the PFC boost preregulator. For most designs, a voltage level of 1.5V on this pin should correspond to low line, and 4.7V for high line. The input range for this pin extends from 0 to 5.5V.

VSENSE: This pin is the inverting input of the voltage amplifier and serves as the output voltage feedback point for the PFC boost converter. It senses the output voltage through a voltage divider which produces a nominal 3V. The voltage loop compensation is normally connected between this pin and VAO. The VSENSE pin must be above 1.5V at 25°C, (1.9V at -55°C) for the current synthesizer to work properly.

ZVS: This pin senses when the drain voltage of the main MOSFET switch has reached approximately zero volts, and resets the ZVT latch via the ZVT comparator. A minimum and maximum ZVTOUT pulse width are programmable from this pin. To directly sense the $\approx 400V$ drain voltage of the main switch, a blocking diode is connected between ZVS and the high voltage drain. When the drain reaches 0V, the level on ZVS is $\approx 0.7V$ which is below the 2.6V ZVT comparator threshold. The maximum ZVTOUT pulse width is approximately equal to the oscillator blanking period time.

ZVTOUT: The output of the ZVT block is a 750mA peak totem pole MOSFET gate driver on ZVTOUT. Since the ZVT MOSFET switch is typically 3X smaller than the main switch, less peak current is required from this output. Like GTOUT, a series gate resistor and Schottky diode to GND are recommended. This pin may also be used as a high current synchronization output driver.

For more information see Unitrode Applications Note U-153.

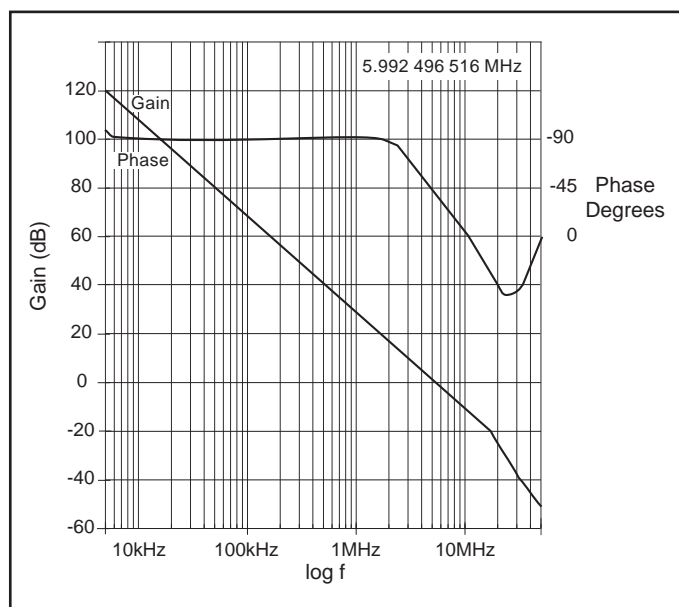

Figure 1. Current Amplifier Frequency Response

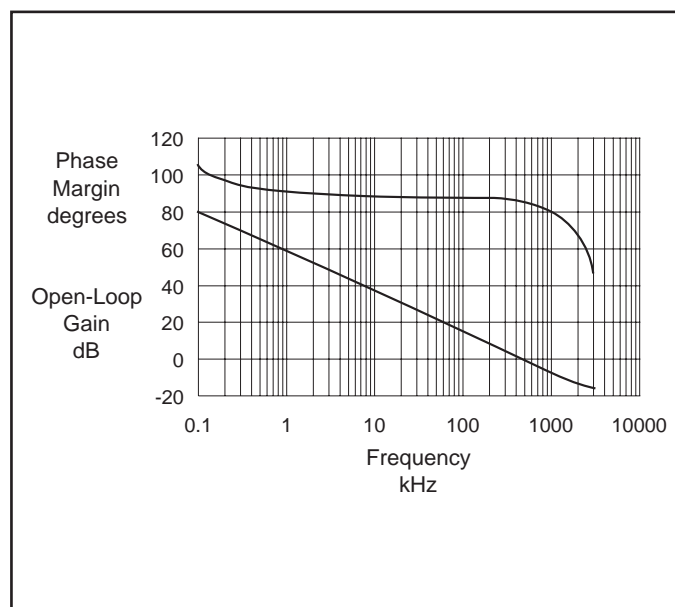

Figure 2. Voltage Amplifier Gain Phase vs Frequency

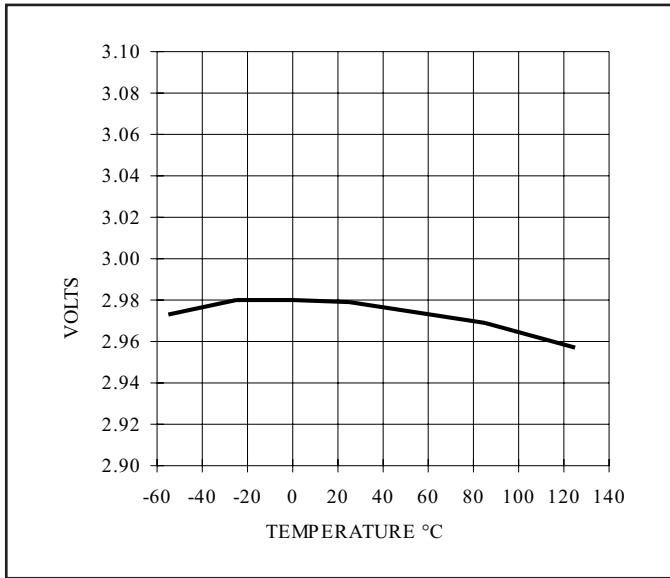

Figure 3. Voltage Amplifier Input Threshold

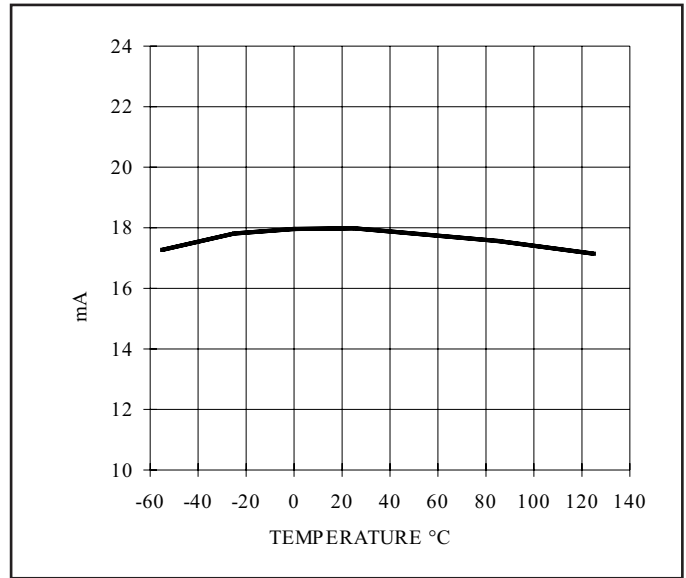

Figure 4. Supply Current ON

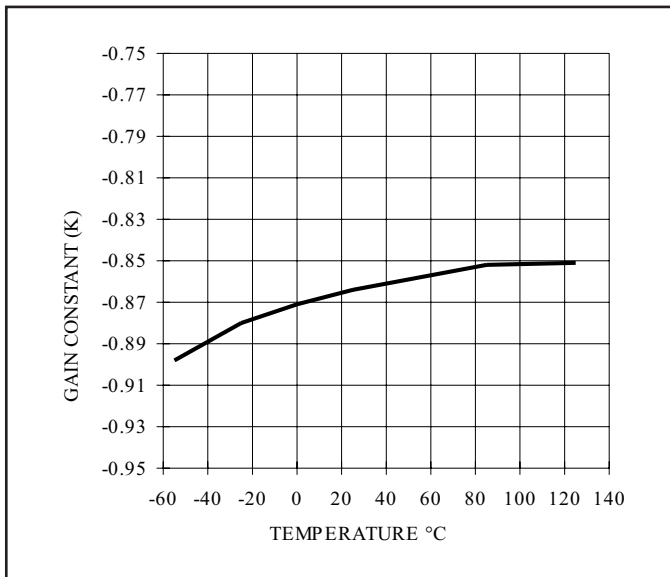

Figure 5. Multiplier Current Gain Constant

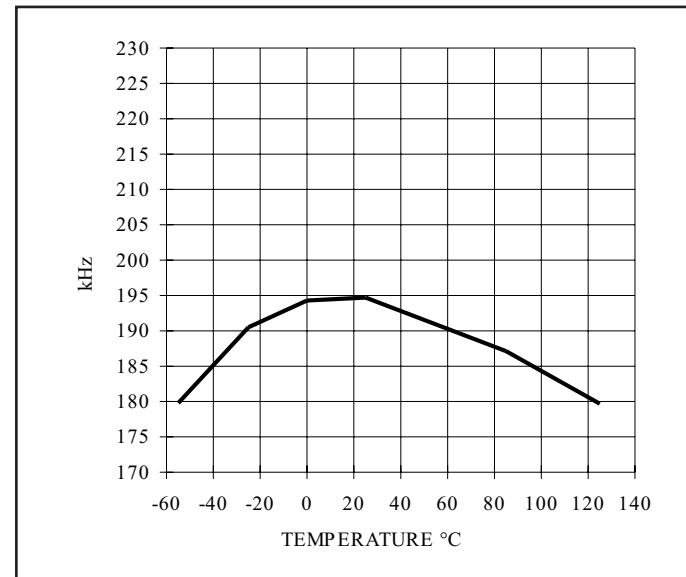

Figure 6. Oscillator Initial Accuracy

PACKAGING INFORMATION

| Orderable Device | Status (1) | Package Type | Package Drawing | Pins | Package Qty | Eco Plan (2) | Lead/Ball Finish (6) | MSL Peak Temp (3) | Op Temp (°C) | Device Marking (4/5) | Samples |
|------------------|---------------|--------------|-----------------|------|-------------|-------------------------|-------------------------|----------------------|--------------|-------------------------|-------------------------|
| UC2855ADW | ACTIVE | SOIC | DW | 20 | 25 | Green (RoHS & no Sb/Br) | CU NIPDAU | Level-2-260C-1 YEAR | -40 to 85 | UC2855ADW | Samples |
| UC2855BDW | ACTIVE | SOIC | DW | 20 | 25 | Green (RoHS & no Sb/Br) | CU NIPDAU | Level-2-260C-1 YEAR | -40 to 85 | UC2855BDW | Samples |
| UC2855BDWG4 | ACTIVE | SOIC | DW | 20 | 25 | Green (RoHS & no Sb/Br) | CU NIPDAU | Level-2-260C-1 YEAR | -40 to 85 | UC2855BDW | Samples |
| UC2855BDWTR | ACTIVE | SOIC | DW | 20 | 2000 | Green (RoHS & no Sb/Br) | CU NIPDAU | Level-2-260C-1 YEAR | -40 to 85 | UC2855BDW | Samples |
| UC2855BDWTRG4 | ACTIVE | SOIC | DW | 20 | 2000 | Green (RoHS & no Sb/Br) | CU NIPDAU | Level-2-260C-1 YEAR | -40 to 85 | UC2855BDW | Samples |
| UC2855BN | ACTIVE | PDIP | N | 20 | 18 | Green (RoHS & no Sb/Br) | CU NIPDAU Call TI | N / A for Pkg Type | -40 to 85 | UC2855BN | Samples |
| UC2855BNG4 | ACTIVE | PDIP | N | 20 | 18 | Green (RoHS & no Sb/Br) | Call TI | N / A for Pkg Type | -40 to 85 | UC2855BN | Samples |
| UC3855ADW | ACTIVE | SOIC | DW | 20 | 25 | Green (RoHS & no Sb/Br) | CU NIPDAU | Level-2-260C-1 YEAR | 0 to 70 | UC3855ADW | Samples |
| UC3855ADWG4 | ACTIVE | SOIC | DW | 20 | 25 | Green (RoHS & no Sb/Br) | CU NIPDAU | Level-2-260C-1 YEAR | 0 to 70 | UC3855ADW | Samples |
| UC3855ADWTR | ACTIVE | SOIC | DW | 20 | 2000 | Green (RoHS & no Sb/Br) | CU NIPDAU | Level-2-260C-1 YEAR | 0 to 70 | UC3855ADW | Samples |
| UC3855BDW | ACTIVE | SOIC | DW | 20 | 25 | Green (RoHS & no Sb/Br) | CU NIPDAU | Level-2-260C-1 YEAR | 0 to 70 | UC3855BDW | Samples |
| UC3855BDWG4 | ACTIVE | SOIC | DW | 20 | 25 | Green (RoHS & no Sb/Br) | CU NIPDAU | Level-2-260C-1 YEAR | 0 to 70 | UC3855BDW | Samples |
| UC3855BDWTR | ACTIVE | SOIC | DW | 20 | 2000 | Green (RoHS & no Sb/Br) | CU NIPDAU | Level-2-260C-1 YEAR | 0 to 70 | UC3855BDW | Samples |
| UC3855BDWTRG4 | ACTIVE | SOIC | DW | 20 | 2000 | Green (RoHS & no Sb/Br) | CU NIPDAU | Level-2-260C-1 YEAR | 0 to 70 | UC3855BDW | Samples |
| UC3855BN | ACTIVE | PDIP | N | 20 | 18 | Green (RoHS & no Sb/Br) | CU NIPDAU Call TI | N / A for Pkg Type | 0 to 70 | UC3855BN | Samples |
| UC3855BNG4 | ACTIVE | PDIP | N | 20 | 18 | Green (RoHS & no Sb/Br) | Call TI | N / A for Pkg Type | 0 to 70 | UC3855BN | Samples |

(1) The marketing status values are defined as follows:
ACTIVE: Product device recommended for new designs.

LIFEBUY: TI has announced that the device will be discontinued, and a lifetime-buy period is in effect.

NRND: Not recommended for new designs. Device is in production to support existing customers, but TI does not recommend using this part in a new design.

PREVIEW: Device has been announced but is not in production. Samples may or may not be available.

OBSELETE: TI has discontinued the production of the device.

⁽²⁾ **RoHS:** TI defines "RoHS" to mean semiconductor products that are compliant with the current EU RoHS requirements for all 10 RoHS substances, including the requirement that RoHS substance do not exceed 0.1% by weight in homogeneous materials. Where designed to be soldered at high temperatures, "RoHS" products are suitable for use in specified lead-free processes. TI may reference these types of products as "Pb-Free".

RoHS Exempt: TI defines "RoHS Exempt" to mean products that contain lead but are compliant with EU RoHS pursuant to a specific EU RoHS exemption.

Green: TI defines "Green" to mean the content of Chlorine (Cl) and Bromine (Br) based flame retardants meet JS709B low halogen requirements of ≤ 1000 ppm threshold. Antimony trioxide based flame retardants must also meet the ≤ 1000 ppm threshold requirement.

⁽³⁾ MSL, Peak Temp. - The Moisture Sensitivity Level rating according to the JEDEC industry standard classifications, and peak solder temperature.

⁽⁴⁾ There may be additional marking, which relates to the logo, the lot trace code information, or the environmental category on the device.

⁽⁵⁾ Multiple Device Markings will be inside parentheses. Only one Device Marking contained in parentheses and separated by a "~" will appear on a device. If a line is indented then it is a continuation of the previous line and the two combined represent the entire Device Marking for that device.

⁽⁶⁾ Lead/Ball Finish - Orderable Devices may have multiple material finish options. Finish options are separated by a vertical ruled line. Lead/Ball Finish values may wrap to two lines if the finish value exceeds the maximum column width.

Important Information and Disclaimer:The information provided on this page represents TI's knowledge and belief as of the date that it is provided. TI bases its knowledge and belief on information provided by third parties, and makes no representation or warranty as to the accuracy of such information. Efforts are underway to better integrate information from third parties. TI has taken and continues to take reasonable steps to provide representative and accurate information but may not have conducted destructive testing or chemical analysis on incoming materials and chemicals. TI and TI suppliers consider certain information to be proprietary, and thus CAS numbers and other limited information may not be available for release.

In no event shall TI's liability arising out of such information exceed the total purchase price of the TI part(s) at issue in this document sold by TI to Customer on an annual basis.

TAPE AND REEL INFORMATION



QUADRANT ASSIGNMENTS FOR PIN 1 ORIENTATION IN TAPE



*All dimensions are nominal

| Device | Package Type | Package Drawing | Pins | SPQ | Reel Diameter (mm) | Reel Width W1 (mm) | A0 (mm) | B0 (mm) | K0 (mm) | P1 (mm) | W (mm) | Pin1 Quadrant |
|-------------|--------------|-----------------|------|------|--------------------|--------------------|---------|---------|---------|---------|--------|---------------|
| UC3855ADWTR | SOIC | DW | 20 | 2000 | 330.0 | 24.4 | 10.8 | 13.3 | 2.7 | 12.0 | 24.0 | Q1 |

TAPE AND REEL BOX DIMENSIONS

*All dimensions are nominal

| Device | Package Type | Package Drawing | Pins | SPQ | Length (mm) | Width (mm) | Height (mm) |
|-------------|--------------|-----------------|------|------|-------------|------------|-------------|
| UC3855ADWTR | SOIC | DW | 20 | 2000 | 367.0 | 367.0 | 45.0 |

N (R-PDIP-T**)

PLASTIC DUAL-IN-LINE PACKAGE

16 PINS SHOWN



- NOTES:
- A. All linear dimensions are in inches (millimeters).
 - B. This drawing is subject to change without notice.
 - $\triangle C$ Falls within JEDEC MS-001, except 18 and 20 pin minimum body length (Dim A).
 - $\triangle D$ The 20 pin end lead shoulder width is a vendor option, either half or full width.

4040049/E 12/2002

DW0020A



PACKAGE OUTLINE

SOIC - 2.65 mm max height

SOIC



4220724/A 05/2016

NOTES:

- All linear dimensions are in millimeters. Dimensions in parenthesis are for reference only. Dimensioning and tolerancing per ASME Y14.5M.
- This drawing is subject to change without notice.
- This dimension does not include mold flash, protrusions, or gate burrs. Mold flash, protrusions, or gate burrs shall not exceed 0.15 mm per side.
- This dimension does not include interlead flash. Interlead flash shall not exceed 0.43 mm per side.
- Reference JEDEC registration MS-013.

EXAMPLE BOARD LAYOUT

DW0020A

SOIC - 2.65 mm max height

SOIC



LAND PATTERN EXAMPLE
SCALE:6X



SOLDER MASK DETAILS

4220724/A 05/2016

NOTES: (continued)

- 6. Publication IPC-7351 may have alternate designs.
- 7. Solder mask tolerances between and around signal pads can vary based on board fabrication site.

EXAMPLE STENCIL DESIGN

DW0020A

SOIC - 2.65 mm max height

SOIC



SOLDER PASTE EXAMPLE
BASED ON 0.125 mm THICK STENCIL
SCALE:6X

4220724/A 05/2016

NOTES: (continued)

8. Laser cutting apertures with trapezoidal walls and rounded corners may offer better paste release. IPC-7525 may have alternate design recommendations.
9. Board assembly site may have different recommendations for stencil design.

IMPORTANT NOTICE

Texas Instruments Incorporated (TI) reserves the right to make corrections, enhancements, improvements and other changes to its semiconductor products and services per JESD46, latest issue, and to discontinue any product or service per JESD48, latest issue. Buyers should obtain the latest relevant information before placing orders and should verify that such information is current and complete.

TI's published terms of sale for semiconductor products (<http://www.ti.com/sc/docs/stdterms.htm>) apply to the sale of packaged integrated circuit products that TI has qualified and released to market. Additional terms may apply to the use or sale of other types of TI products and services.

Reproduction of significant portions of TI information in TI data sheets is permissible only if reproduction is without alteration and is accompanied by all associated warranties, conditions, limitations, and notices. TI is not responsible or liable for such reproduced documentation. Information of third parties may be subject to additional restrictions. Resale of TI products or services with statements different from or beyond the parameters stated by TI for that product or service voids all express and any implied warranties for the associated TI product or service and is an unfair and deceptive business practice. TI is not responsible or liable for any such statements.

Buyers and others who are developing systems that incorporate TI products (collectively, "Designers") understand and agree that Designers remain responsible for using their independent analysis, evaluation and judgment in designing their applications and that Designers have full and exclusive responsibility to assure the safety of Designers' applications and compliance of their applications (and of all TI products used in or for Designers' applications) with all applicable regulations, laws and other applicable requirements. Designer represents that, with respect to their applications, Designer has all the necessary expertise to create and implement safeguards that (1) anticipate dangerous consequences of failures, (2) monitor failures and their consequences, and (3) lessen the likelihood of failures that might cause harm and take appropriate actions. Designer agrees that prior to using or distributing any applications that include TI products, Designer will thoroughly test such applications and the functionality of such TI products as used in such applications.

TI's provision of technical, application or other design advice, quality characterization, reliability data or other services or information, including, but not limited to, reference designs and materials relating to evaluation modules, (collectively, "TI Resources") are intended to assist designers who are developing applications that incorporate TI products; by downloading, accessing or using TI Resources in any way, Designer (individually or, if Designer is acting on behalf of a company, Designer's company) agrees to use any particular TI Resource solely for this purpose and subject to the terms of this Notice.

TI's provision of TI Resources does not expand or otherwise alter TI's applicable published warranties or warranty disclaimers for TI products, and no additional obligations or liabilities arise from TI providing such TI Resources. TI reserves the right to make corrections, enhancements, improvements and other changes to its TI Resources. TI has not conducted any testing other than that specifically described in the published documentation for a particular TI Resource.

Designer is authorized to use, copy and modify any individual TI Resource only in connection with the development of applications that include the TI product(s) identified in such TI Resource. NO OTHER LICENSE, EXPRESS OR IMPLIED, BY ESTOPPEL OR OTHERWISE TO ANY OTHER TI INTELLECTUAL PROPERTY RIGHT, AND NO LICENSE TO ANY TECHNOLOGY OR INTELLECTUAL PROPERTY RIGHT OF TI OR ANY THIRD PARTY IS GRANTED HEREIN, including but not limited to any patent right, copyright, mask work right, or other intellectual property right relating to any combination, machine, or process in which TI products or services are used. Information regarding or referencing third-party products or services does not constitute a license to use such products or services, or a warranty or endorsement thereof. Use of TI Resources may require a license from a third party under the patents or other intellectual property of the third party, or a license from TI under the patents or other intellectual property of TI.

TI RESOURCES ARE PROVIDED "AS IS" AND WITH ALL FAULTS. TI DISCLAIMS ALL OTHER WARRANTIES OR REPRESENTATIONS, EXPRESS OR IMPLIED, REGARDING RESOURCES OR USE THEREOF, INCLUDING BUT NOT LIMITED TO ACCURACY OR COMPLETENESS, TITLE, ANY EPIDEMIC FAILURE WARRANTY AND ANY IMPLIED WARRANTIES OF MERCHANTABILITY, FITNESS FOR A PARTICULAR PURPOSE, AND NON-INFRINGEMENT OF ANY THIRD PARTY INTELLECTUAL PROPERTY RIGHTS. TI SHALL NOT BE LIABLE FOR AND SHALL NOT DEFEND OR INDEMNIFY DESIGNER AGAINST ANY CLAIM, INCLUDING BUT NOT LIMITED TO ANY INFRINGEMENT CLAIM THAT RELATES TO OR IS BASED ON ANY COMBINATION OF PRODUCTS EVEN IF DESCRIBED IN TI RESOURCES OR OTHERWISE. IN NO EVENT SHALL TI BE LIABLE FOR ANY ACTUAL, DIRECT, SPECIAL, COLLATERAL, INDIRECT, PUNITIVE, INCIDENTAL, CONSEQUENTIAL OR EXEMPLARY DAMAGES IN CONNECTION WITH OR ARISING OUT OF TI RESOURCES OR USE THEREOF, AND REGARDLESS OF WHETHER TI HAS BEEN ADVISED OF THE POSSIBILITY OF SUCH DAMAGES.

Unless TI has explicitly designated an individual product as meeting the requirements of a particular industry standard (e.g., ISO/TS 16949 and ISO 26262), TI is not responsible for any failure to meet such industry standard requirements.

Where TI specifically promotes products as facilitating functional safety or as compliant with industry functional safety standards, such products are intended to help enable customers to design and create their own applications that meet applicable functional safety standards and requirements. Using products in an application does not by itself establish any safety features in the application. Designers must ensure compliance with safety-related requirements and standards applicable to their applications. Designer may not use any TI products in life-critical medical equipment unless authorized officers of the parties have executed a special contract specifically governing such use. Life-critical medical equipment is medical equipment where failure of such equipment would cause serious bodily injury or death (e.g., life support, pacemakers, defibrillators, heart pumps, neurostimulators, and implantables). Such equipment includes, without limitation, all medical devices identified by the U.S. Food and Drug Administration as Class III devices and equivalent classifications outside the U.S.

TI may expressly designate certain products as completing a particular qualification (e.g., Q100, Military Grade, or Enhanced Product). Designers agree that it has the necessary expertise to select the product with the appropriate qualification designation for their applications and that proper product selection is at Designers' own risk. Designers are solely responsible for compliance with all legal and regulatory requirements in connection with such selection.

Designer will fully indemnify TI and its representatives against any damages, costs, losses, and/or liabilities arising out of Designer's non-compliance with the terms and provisions of this Notice.