

未注公差/General tolerances (mm)											D 0.1/10		
0	>3	>6	>10	>18	>30	>50	>80	>120	>180	>250		>315	>400
~ 3	~ 6	~ 10	~ 18	~ 30	~ 50	~ 80	~ 120	~ 180	~ 250	~ 315	~ 400	~ 500	~ >500
±0.12	±0.18	±0.22	±0.26	±0.31	±0.37	±0.57	±0.80	±0.93	±1.05	±1.15	±1.60	±2.20	±2.50

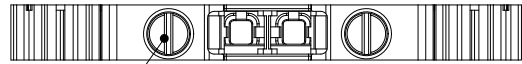

4

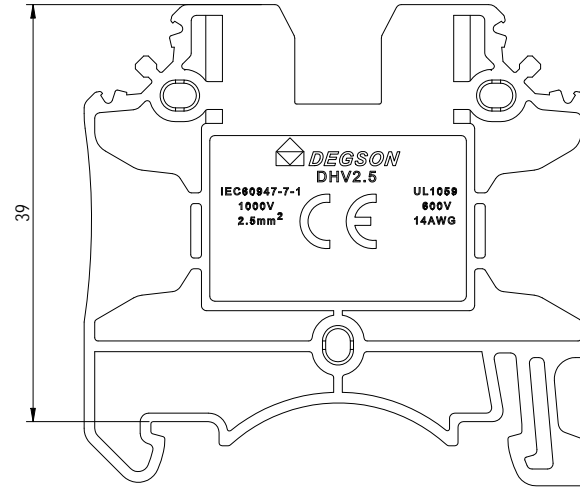
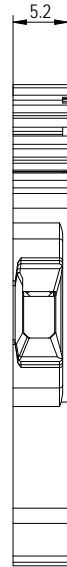
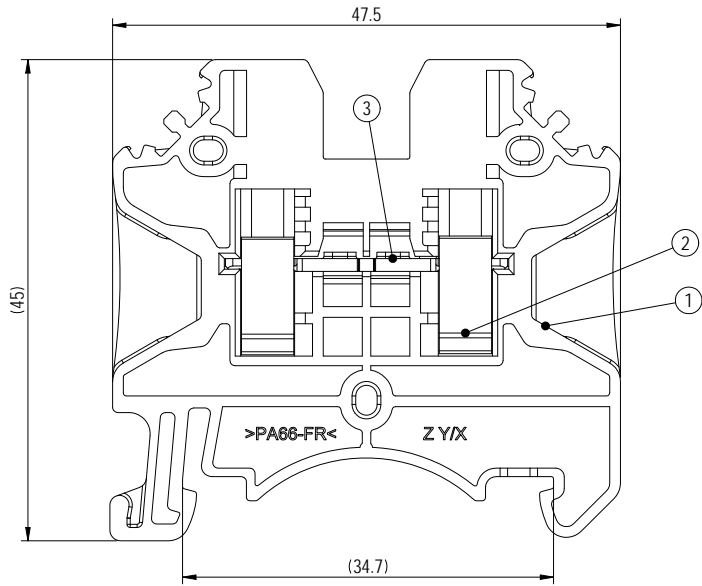

ITEM	NAME OF PART	MATERIAL	NOTES
4	Screw	Copper Alloy	M3,Ni Plated
3	Current carrier	Copper Alloy	Sn Plated
2	Cage	Copper Alloy	Ni Plated
1	Housing	PA66	UL94 V-0

UL 标准/UL Standard	B	C	D
额定电压/电压/Rated Voltage(V)/Current(A)	600/20	600/20	/
IEC 标准/IEC Standard			
过压类别/Overvoltage Category/污染等级/Pollution Degree	III/3	III/2	II/2
额定电压/电压/Rated Voltage(V)/Current(A)	1000/24	/	/
额定脉冲电压(kV)/Rate Impulse Voltage(kV)	8	/	/
螺丝扭矩/Torque Tightening(N·m/Lbin)	M3, 0.5- 0.6/4.43- 5.32		
线径范围(硬线和软线)/Wire Range(rigid and flexible)(AWG/mm²)	26- 14,12(SQ)0.14- 2.5,4(SQ)		
间距/Pitch(mm)/线数范围/Roles	5.20/N= 01P		
剥线长度/Stripping length(mm)	9- 10		
使用温度范围/Operating temperature(°C)	-60- + 105		
符合RoHS环保要求/Conform to RoHS	Yes		

DEGSON	MATERIAL:	SURFACE/COLOR:
	MAT NO./REV: 11010001081-1 / 01	MAT STATUS: 批量

APPD: 彭敏	2023.10.20	NAME	DHV2.5-01P-1Y-00A&Z(H)		
CHKD: 高正国	2023.10.20	DRAWING NO.	200105006	TYPE	CUSTOMER DRAWING
DRFT: 刘玉	2023.10.20	DRAWING STATUS	已发布	SCALE	1:1
REV	ECN	DESCRIPTION	DRFT	DATE	SHEET
					1/1

03		Release drawing for MP.	刘玉	2023.10.20
REV	ECN	DESCRIPTION	DRFT	DATE

Transfer or duplication of this document as well as the utilization of its contents in any form without the written permission of DEGSON is prohibited. All rights reserved for patent. 本文件及其内容之复制或在本文件内容之基础上进行任何形式的再复制或再生产，均须经本公司事先书面许可。本公司保留所有权利。