

REVISION RECORD				
REV	ECO	DESCRIPTION	DRFT	DATE
△		品名、料号增加环保标示“(H)”	LJH	12/08/07
△	P9-0119	增加VDE刻字及参数	GHY	11/24/08

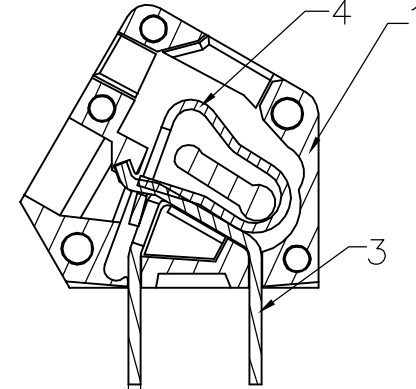
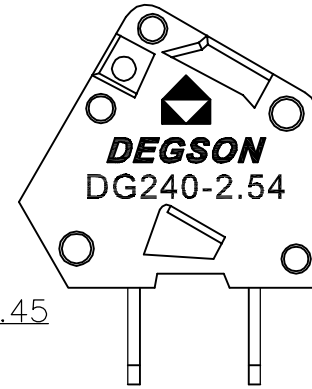
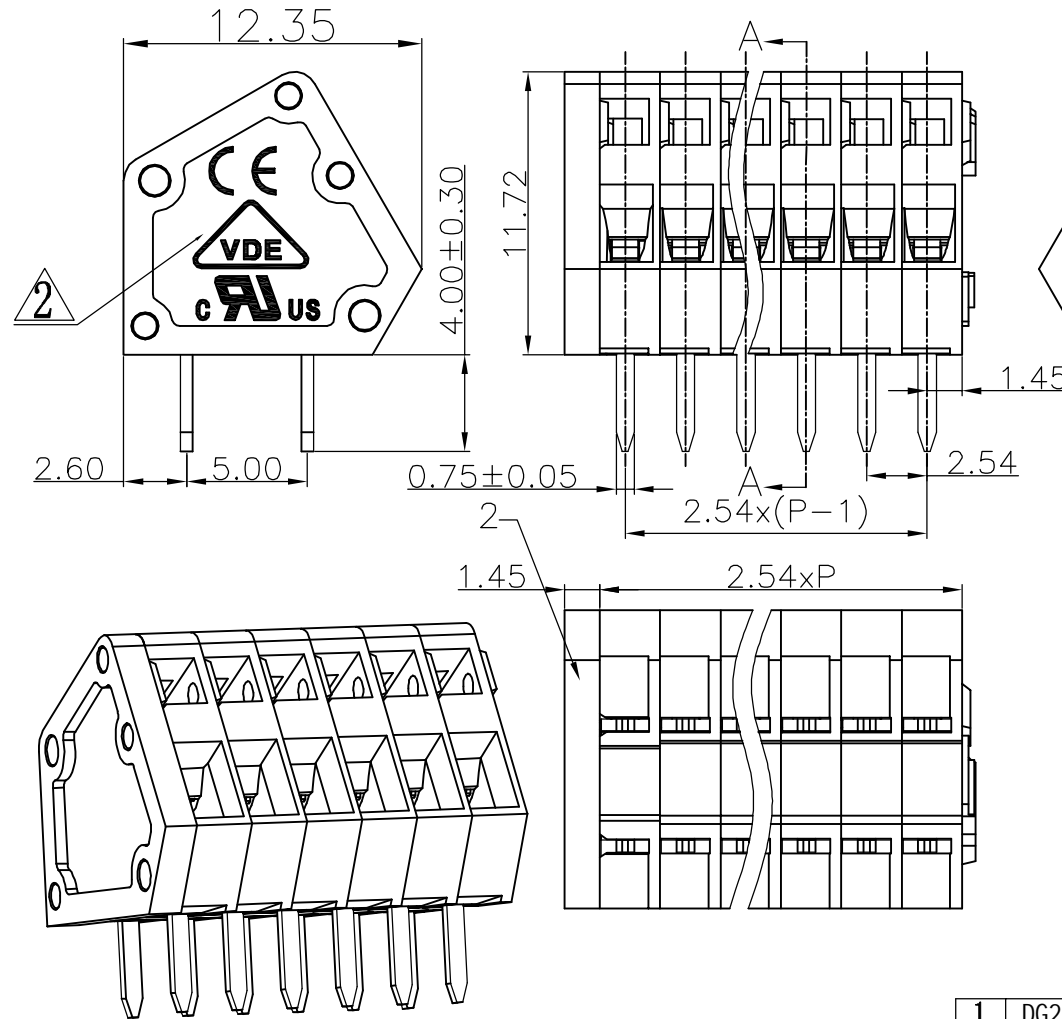

SECTION A-A

Notes:

- Pitch: 2.54mm, Poles: 2-24P
- Rated voltage / current: UL 150V/4A
VDE 130V/6A
- Operation temperatures: -40°C ~ +105°C
- Withstanding Voltage: AC1500V/1Min
- Insulation Resistance: 5000MΩ / DC1000V
- Wire Range: 28~20AWG, 0.2~0.5mm²
- Undimensioned Tolerances:

Pitch range in mm		Nominal dimension range in mm				
to 6	over 6 to 10	over 10 to 24	over 30 to 60	over 60 to 100	over 100 to 150	—
±0.10	±0.15	±0.25	±0.2	±0.3	±0.5	±0.7
						±1.0 0.05/10

4	DG240 Spring	X000001020(H)	XX	Stainless steel	
3	DG240 Pin header	3013B00010(H)	XX	Phosphor bronze	SnCe plated
2	DG240-2.54-Cover	3013C0Y01A(H)1		PA66	UL94V-0

ITEM	NAME OF PART	NO. OF PART	Q'TY	MATERIAL	NOTES
1	DG240-2.54- Housing	3013A0Y01A(H)	XX	PA66	UL94V-0

DFTO L1N DATE 11/16/06" CHKD DATE MFO DATE APPVL DATE MATERIAL : ANGLES ± 1° FINISH : SCALE : THIRD ANGLE PROJECTION	宁波高正电子有限公司 DEGSON® DEGSON ELECTRONICS CO., LTD NAME DG240W-2.54-XXP-1Y-00A(H) DRAWING NO. DG240W-2.54-E01 /PART NO. DO NOT SCALE DRAWING	SIZE A3 REV T2 11/24/08
--	--	-------------------------------------