

## DETAILS

<b>Product Number</b>	CA10823_STRADA-A
<b>Family</b>	Strada
<b>Type</b>	Assembly
<b>Color</b>	clear
<b>Diameter</b>	19,6 x 15,5 mm
<b>Height</b>	10,65 mm
<b>Style</b>	rectang
<b>Optic Material</b>	PMMA
<b>Holder Material</b>	
<b>Fastening</b>	tape, screw
<b>Status</b>	production ready
<b>ROHS Compliant</b>	Yes
<b>Date Updated</b>	10/05/2017



## OPTICAL PROPERTIES

LED	Viewing Angle	Light Beam	Efficiency	cd/lm	Connector
XP-E	68+136 deg	Streetligh...	93 %	1.100	-
XP-G	80+144 deg	Streetligh...	93 %	0.850	-
H35C0 (LEMWA33)	82+139 deg	Streetligh...	91 %	1.000	-
Z5	sim: 35+65	Streetligh...	92 %	-	-

D

C

B

A

4

4

Tape 0.4mm

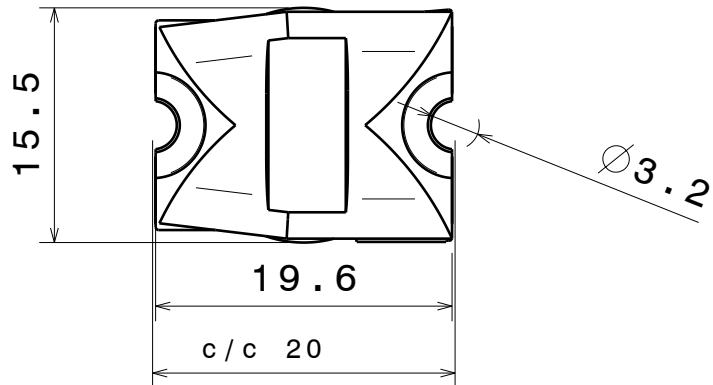
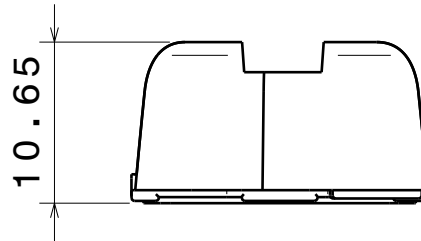
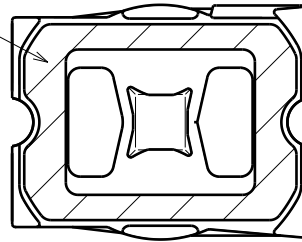

Material:  
 Lens PMMA  
 Tape PU foam with PSA

2

2

This drawing is our property.  
 It can't be reproduced  
 or communicated without  
 our written agreement.



L  
T  
F  
F

e  
e  
i  
i  
n  
n

d  
h

DRAWING TITLE

Datasheet Strada-A-XP assy

1

1

DRAWN BY

DATE

p

05.08.2011

CHECKED BY

DATE

t

k

07.07.2011

DESIGNED BY

DATE

hh

20.11.2008

SIZE

DRAWING NUMBER

REV

A4

1

SCALE

2:1

WEIGHT (g)

SHEET

1/1

D

A

Luminaire: Ledil Oy CA10823\_Strada-A-XP CA10823\_Strada-A-XP  
Lamps: 1 x Cree XP-E (white)

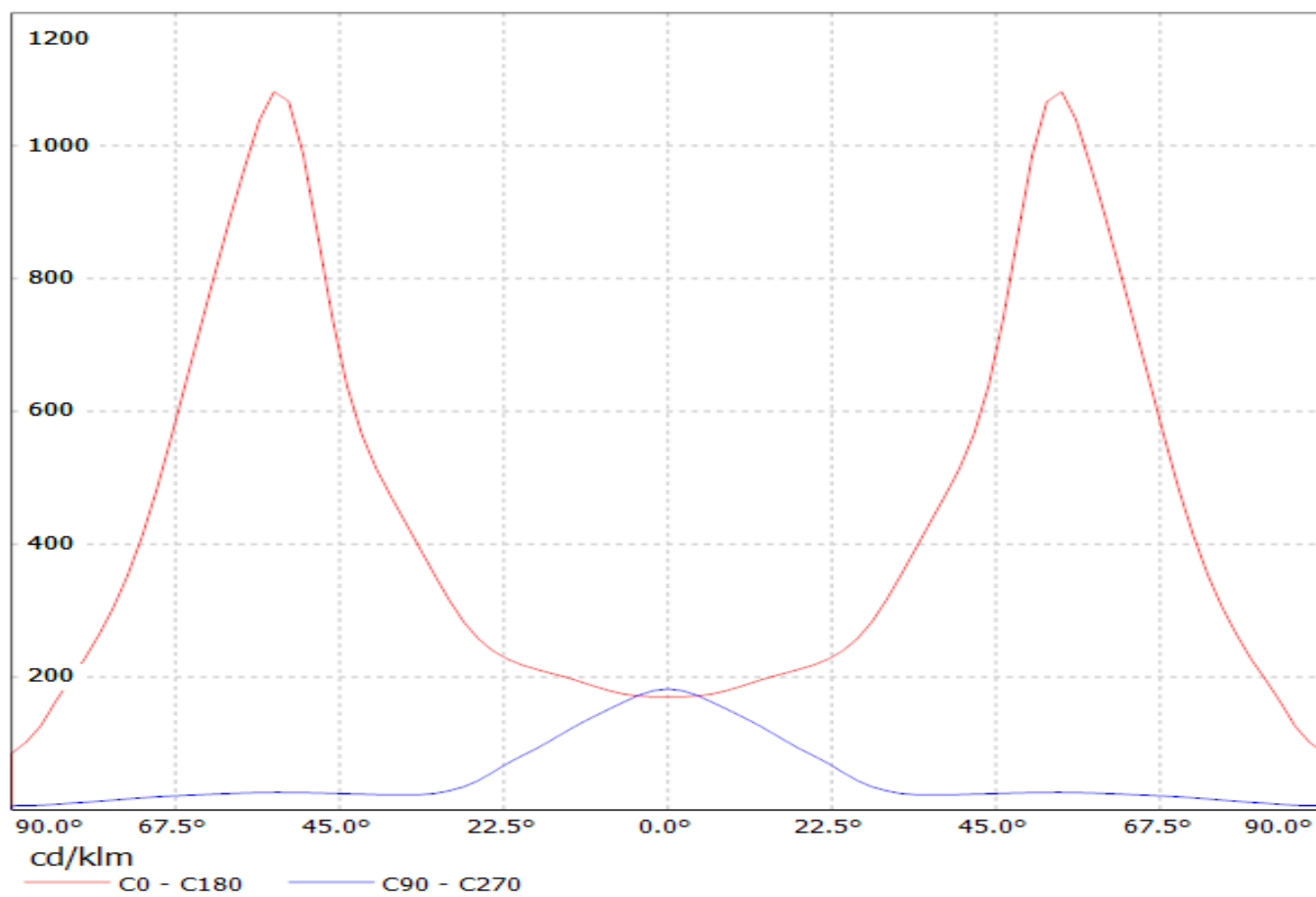

Luminaire: Ledil Oy CA10823\_Strada-A-XPG CA10823\_Strada-A-XPG  
Lamps: 1 x Cree XP-G (White)

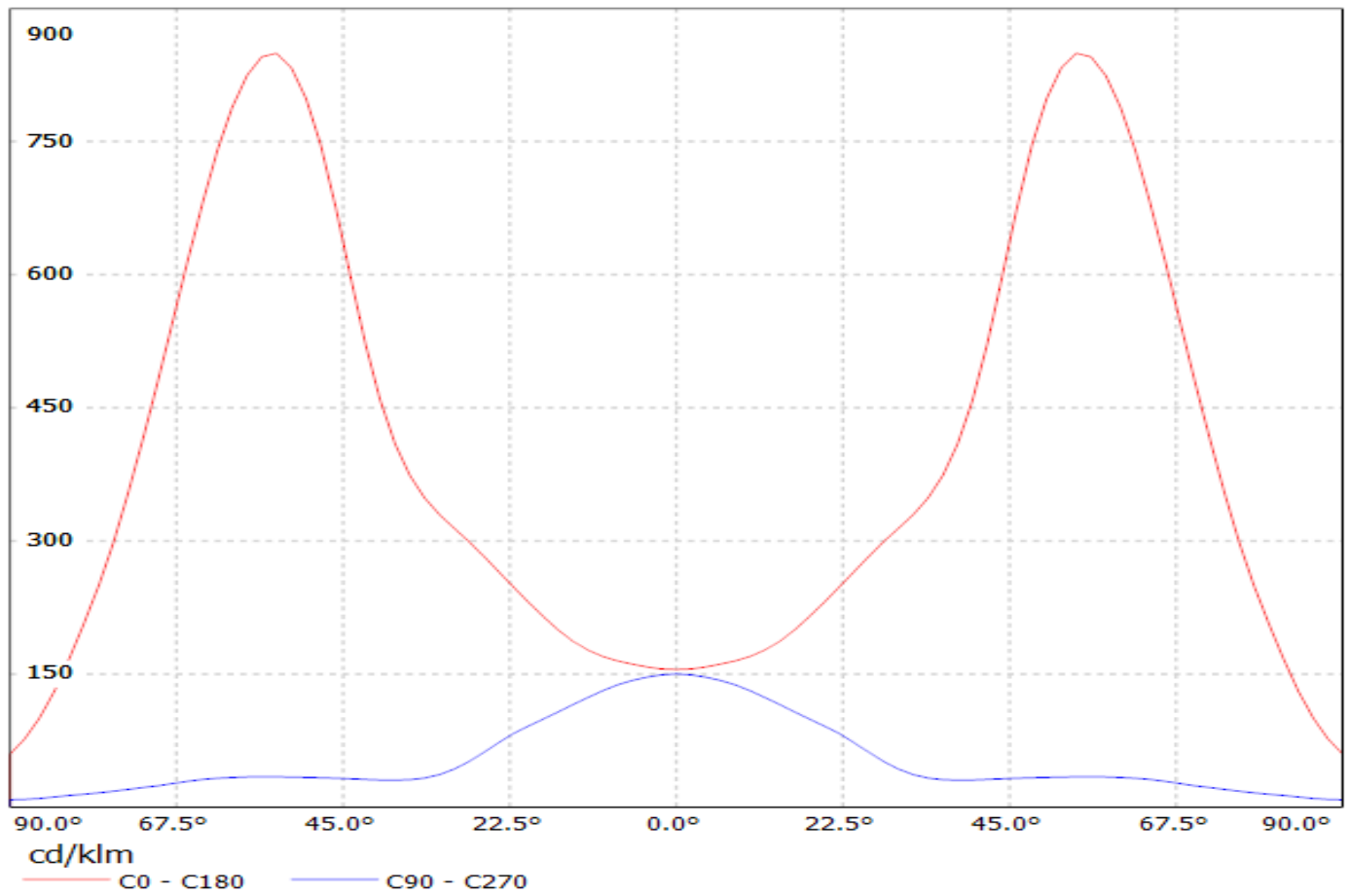

Luminaire: Ledil Oy CA10823\_Strada-A-XP CA10823\_Strada-A-XP  
Lamps: 1 x Cree XP-E (white)

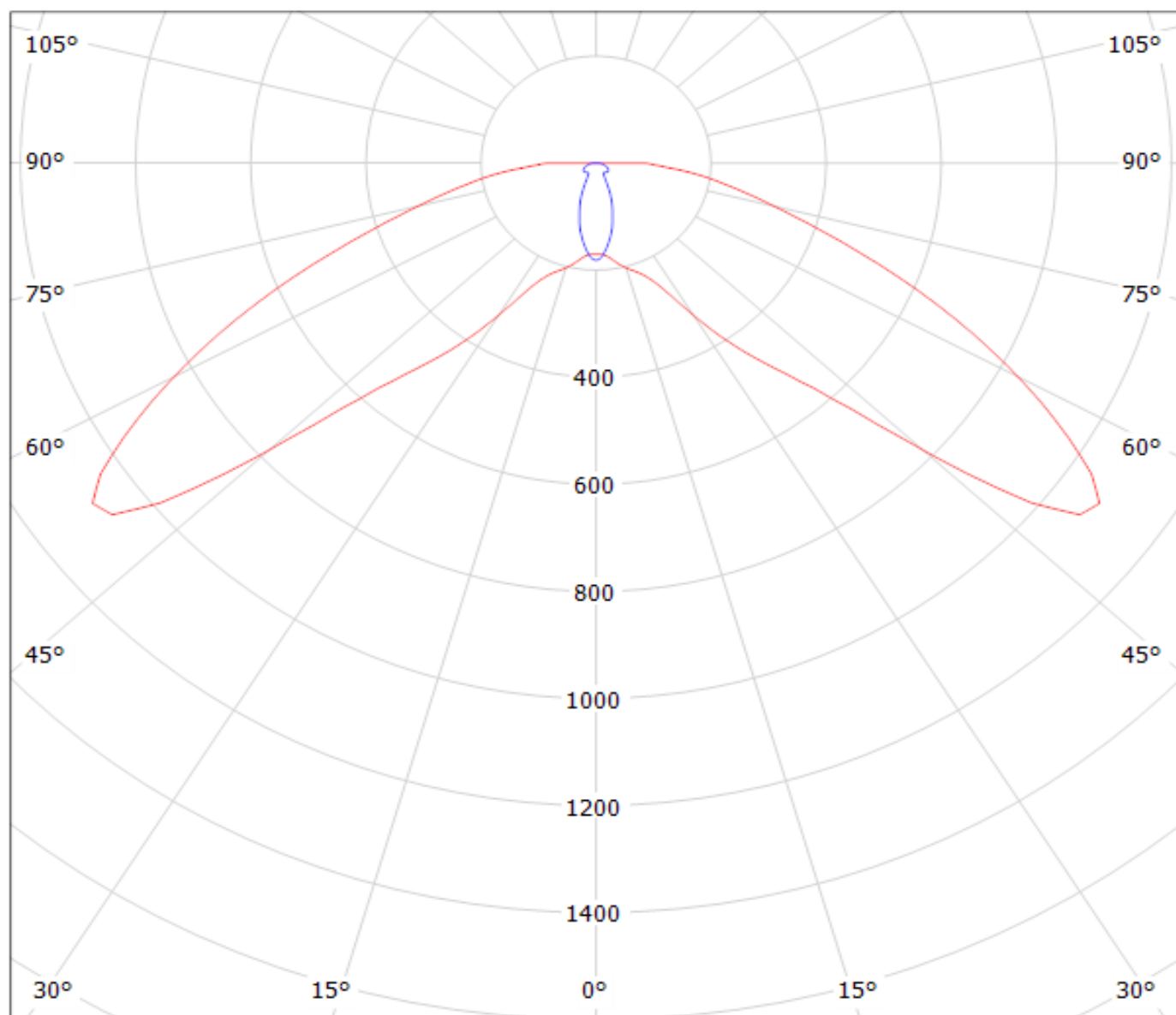

cd/klm

— C0 - C180

— C90 - C270

Luminaire: Ledil Oy CA10823\_Strada-A-XPG CA10823\_Strada-A-XPG  
Lamps: 1 x Cree XP-G (White)

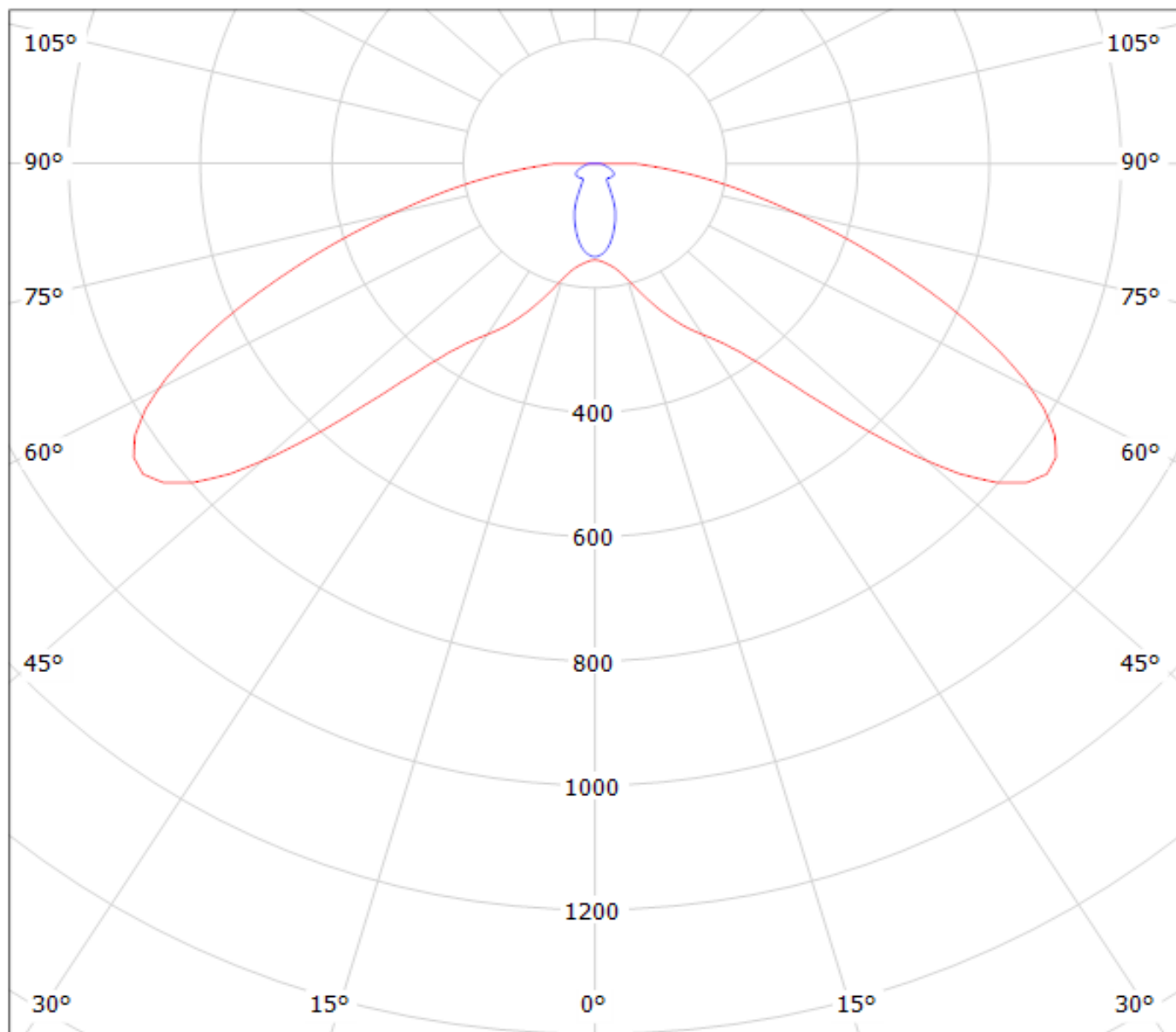

cd/klm

— C0 - C180

— C90 - C270

**NOTE: The typical divergence will be changed by different color, chip size and chip position tolerance. The typical total divergence is the full angle measured where the luminous intensity is half of the peak value.**