

**Magnetic Transducer****EMX- 7T12PA**RoHS
Compliant

Rev.2

**FEATURES:** □

- Low Frequency
- Low Voltage
- Small and Slim Size

APPLICATIONS:

- Automatic Control Equipment
- Communication Equipment
- Electronic Instruments

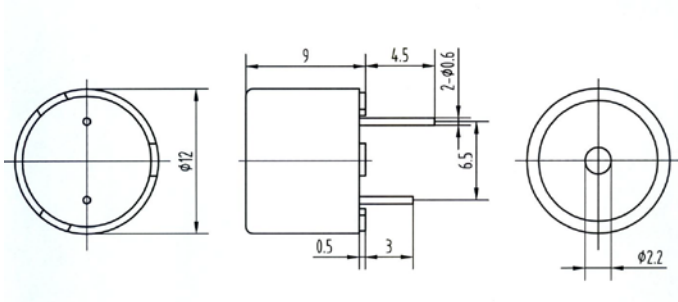
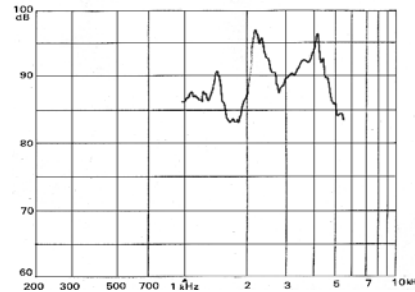
DIMENSIONS: (Unit: mm)**CHARACTERISTICS:****ELECTRICAL SPECIFICATIONS:**

Min. Sound Pressure Level at 12V/2400Hz/10cm.....	85dB(A)
Rated Voltage.....	12V
Operating Voltage.....	6~15V
Max. Consumption at 2400Hz/12Vp-p Square Wave.....	40mA/12V _{DC}
Resonant Frequency.....	2400Hz
D.C Resistance.....	140±14Ω
Operating Temperature.....	-40~+85°C
Storage Temperature.....	-40~+85°C
Case Material.....	PBT
Weight.....	1.7g

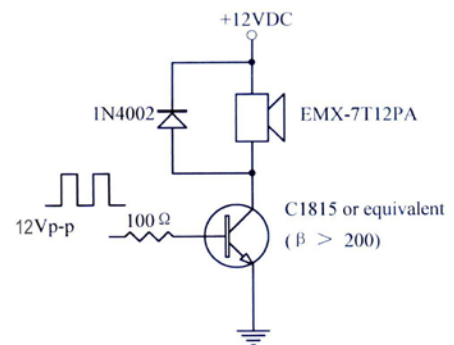
TEST CIRCUIT:**PACKING INFORMATION:**

Packing: 3000 pcs per export carton

Carton Size: 47x25x28cm

G. Weight: 6.6 kgs N. Weight: 5.1 kgs

Address: No. 88. Jinhui East Road Yinzhou, Ningbo, 315104 P. R. China

Sales Tel: +86-574-87809820(International)/87805605(Domestic)

Fax: +86-574-87803761