



Winstar Display Co., LTD

華凌光電股份有限公司



住址: 407 台中市中清路 163 號
No.163 Chung Ching RD.,
Taichune, Taiwan, R.O.C

WEB: <http://www.winstar.com.tw>
<http://ic-contract.ru>
E-mail: winstar@winstar.com.tw
Tel:886-4-24262208 Fax : 886-4-24262207

SPECIFICATION

CUSTOMER : IC Contract

MODULE NO.: WF57DTIBCDBT0#

20130424

<p style="text-align: center;">APPROVED BY:</p> <p>(FOR CUSTOMER USE ONLY)</p>	<p>PCB VERSION: DATA:</p>
---	--

SALES BY	APPROVED BY	CHECKED BY	PREPARED BY
			丘惠城
ISSUED DATE:	2013-7-13		



MODLE NO :

RECORDS OF REVISION

DOC. FIRST ISSUE

VERSION	DATE	REVISED PAGE NO.	SUMMARY
0	2013.7.2		First issue
A	2013.7.13	10	Correction of the interface

Contents

- 1. Module Classification Information**
- 2. Summary**
- 3. General Specification**
- 4. Absolute Maximum Ratings**
- 5. Electrical Characteristics**
- 6. DC Characteristics**
- 7. Interface Timing**
- 8. Optical Characteristics**
- 9. Interface**
- 10. Block Diagram**
- 11. Reliability**
- 12. Touch Panel Information**
- 13. Contour Drawing**
- 14. Package Specification**
- 15. Initial Code For Reference**

1.Module Classification Information

W F 57 D T I B C D B T 0 #
 ○,1 ○,2 ○,3 ○,4 ○,5 ○,6 ○,7 ○,8 ○,9 ○,10 ○,11 ○,12 ○,13 ○,14

①	Brand : WINSTAR DISPLAY CORPORATION						
②	Display Type : H→Character Type, G→Graphic Type F→TFT Type						
③	Display Size : 5.7” TFT						
④	Model serials no.						
⑤	Backlight Type :	F→CCFL, White			T→LED, White		
⑥	LCD Polarize Type/ Temperature range/ Gray Scale Inversion Direction	I→Transmissive, W. T, 6:00 L→Transmissive, W.T,12:00					
⑦	A : TFT LCD B : TFT+FR+CONTROL BOARD C : TFT+FR+A/D BOARD D : TFT+FR+A/D BOARD+CONTROL BOARD E : TFT+FR+POWER BOARD F : TFT+CONTROL BOARD			G : TFT+FR H : TFT+D/V BOARD I : TFT+FR+D/V BOARD J : TFT+POWER BD			
⑧	Solution:						
	A: 128160	B:320234	C:320240	D:480234	E:480272	F: 640480	G: 800480
	H:1024600	I:320480	J:240320	K:800600	L:240400	M :1024768	
On	D: Digital L : LVDS						
On	Interface : N : without control board A : 8Bit B : 16Bit						
On	TS : N : Without TS T : resistive touch panel C : capacitive touch panel						
On	Version						
On	Special Code	#.Fit in with ROHS directive regulations					
On	TBD						

2.Summary

This technical specification applies to 5.7' color TFT-LCD panel. The 5.7' color TFT-LCD panel is designed for camcorder, digital camera application and other electronic products which require high quality flat panel displays. This module follows RoHS.

3.General Specification

Item	Dimension	Unit
Dot Matrix	320 x RGBx240(TFT)	dots
Module dimension	126x 101.55 x 12.0	mm
Active area	115.2 x 86.76	mm
Dot pitch	0.12 x 0.36	mm
LCD type	TFT, Negative, Transmissive	
View Direction	12 o'clock	
Gray Scale Inversion Direction	6 o'clock	
Backlight Type	LED ,Normally White	
Controller IC	SSD1963	
Interface	Digital 8080 family MPU	

*Color tone slight changed by temperature and driving voltage.

4.Absolute Maximum Ratings

Item	Symbol	Min	Typ	Max	Unit
Operating Temperature	TOP	-20	—	+70	°C
Storage Temperature	TST	-30	—	+80	°C

Note: Device is subject to be damaged permanently if stresses beyond those absolute maximum ratings listed above

1. Temp. $\leq 60^{\circ}\text{C}$, 90% RH MAX. Temp. $> 60^{\circ}\text{C}$, Absolute humidity shall be less than 90% RH at 60°C

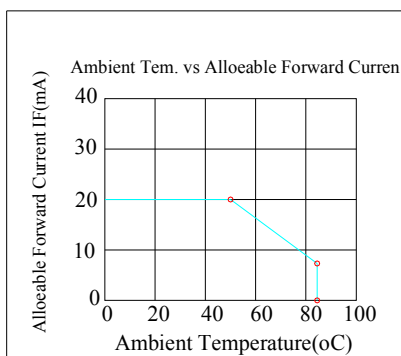

5. Electrical Characteristics

5.1. Operating conditions:

Item	Symbol	Condition	Min	Typ	Max	Unit
Supply Voltage For Logic	VDD	—	3.0	3.3	3.6	V

5.2 LED driving conditions

Parameter	Symbol	Min.	Typ.	Max.	Unit	Remark
LED current		-	140	-	mA	
Power Consumption		1260	-	1470	mW	
LED voltage	VBL+	9.0	-	10.5	V	Note 1
LED Life Time		-	50,000	-	Hr	Note 2,3,4

Note 1 : There are 1 Groups LED

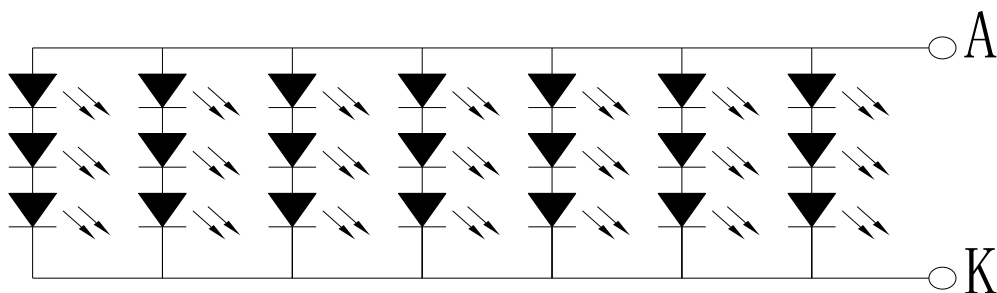

Note 2 : $T_a = 25\text{ }^\circ\text{C}$

Note 3 : Brightness to be decreased to 50% of the initial value

Note 4 : The single LED lamp case

6. DC Characteristics

Parameter	Symbol	Rating			Unit	Condition
		Min	Typ	Max		
Low level input voltage	V_{IL}	0	-	0.3 VDD	V	
Hight level input voltage	V_{IH}	0.7 VDD	-	VDD	V	

7. Interface Timing

7.1.1 8080 Mode

The 8080 mode MCU interface consist of CS#, D/C#, RD#, WR#, D[23:0] and TE signals (Please refer to Table 6-1 for pin multiplexed with 6800 mode). This interface use WR# to define a write cycle and RD# for read cycle. If the WR# goes low when the CS# signal is low, the data or command will be latched into the system at the rising edge of WR#. Similarly, the read cycle will start when RD# goes low and end at the rising edge of RD#.

7.1.2 8080 Mode Write Cycle

Symbol	Parameter	Min	Typ	Max	Unit
t_{cyc}	Reference Clock Cycle Time	9	-	-	ns
t_{PWCSL}	Pulse width CS# low	1	-	-	t_{cyc}
t_{PWCSH}	Pulse width CS# high	1	-	-	t_{cyc}
t_{FDRD}	First Read Data Delay	5	-	-	t_{cyc}
t_{AS}	Address Setup Time	1	-	-	ns
t_{AH}	Address Hold Time	1	-	-	ns
t_{DSW}	Data Setup Time	4	-	-	ns
t_{DHW}	Data Hold Time	1	-	-	ns
t_{DSR}	Data Access Time	-	-	5	ns
t_{DHR}	Output Hold Time	1	-	-	ns

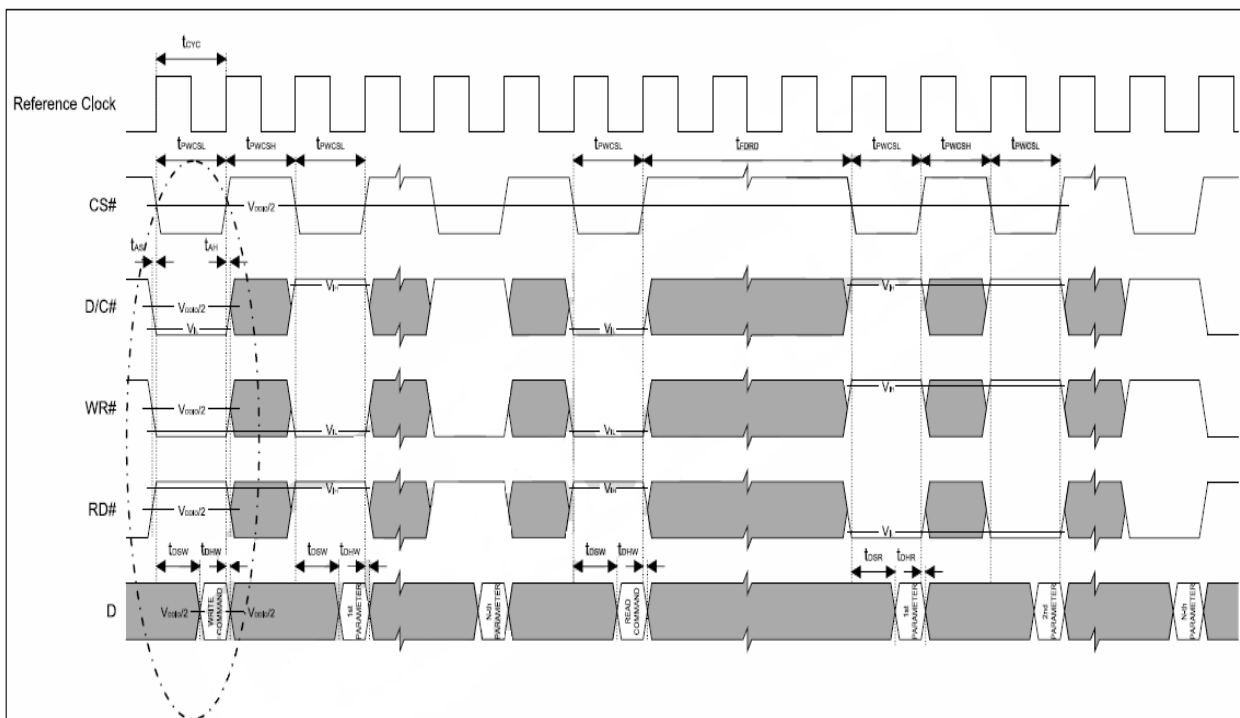

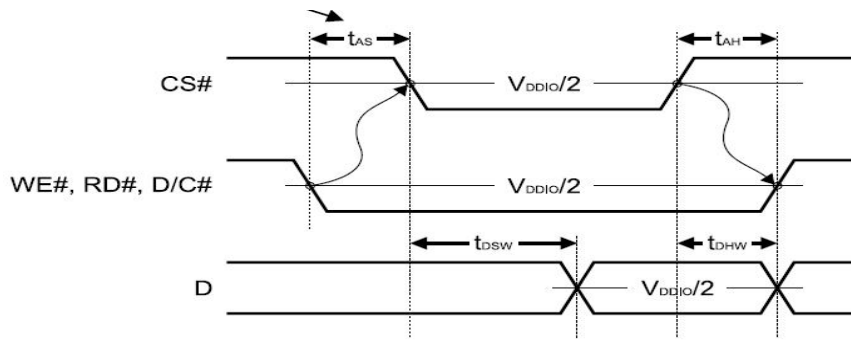

7.1.3 Pixel Data Format

Interface	Cycle	D[23]	D[22]	D[21]	D[20]	D[19]	D[18]	D[17]	D[16]	D[15]	D[14]	D[13]	D[12]	D[11]	D[10]	D[9]	D[8]	D[7]	D[6]	D[5]	D[4]	D[3]	D[2]	D[1]	D[0]	
24 bits	1 st	R7	R6	R5	R4	R3	R2	R1	R0	G7	G6	G5	G4	G3	G2	G1	G0	B7	B6	B5	B4	B3	B2	B1	B0	
18 bits	1 st							R5	R4	R3	R2	R1	R0	G5	G4	G3	G2	G1	G0	B5	B4	B3	B2	B1	B0	
16 bits (565 format)	1 st									R5	R4	R3	R2	R1	G5	G4	G3	G2	G1	G0	B5	B4	B3	B2	B1	
16 bits	1 st									R5	R4	R3	R2	R1	R0	X	X	G5	G4	G3	G2	G1	G0	X	X	
	2 nd									B5	B4	B3	B2	B1	B0	X	X	R5	R4	R3	R2	R1	R0	X	X	
	3 rd									G5	G4	G3	G2	G1	G0	X	X	B5	B4	B3	B2	B1	B0	X	X	
9 bits	1 st																	R5	R4	R3	R2	R1	R0	G5	G4	G3
	2 nd																	G2	G1	G0	B5	B4	B3	B2	B1	B0
8 bits	1 st																	R5	R4	R3	R2	R1	R0	X	X	
	2 nd																	G5	G4	G3	G2	G1	G0	X	X	
	3 rd																	B5	B4	B3	B2	B1	B0	X	X	

X: Don't Care

8. Optical Characteristic

Item	Symbol	Condition.	Min	Typ.	Max.	Unit	Remark	
Response time	Tr	$\theta=0^\circ$ 、 $\Phi=0^\circ$	15	30		.ms	Note 3,5	
	Tf		35	50		.ms		
Contrast ratio	CR	At optimized viewing angle	150	200	-	-	Note 4,5	
Color Chromaticity	White	Wx	$\theta=0^\circ$ 、 $\Phi=0$	0.27	0.32	0.37		Note 2,6,7
		Wy		0.30	0.35	0.40		
Viewing angle	Hor.	Θ_R	CR ≥ 10	60	70		Deg.	Note 1
		Θ_L		60	70			
	Ver.	Φ_T		40	50			
		Φ_B		60	70			
Brightness	-	-	240	400		cd/m ²	Center of display	

Ta=25±2°C, IL=20mA

Note 1: Definition of viewing angle range

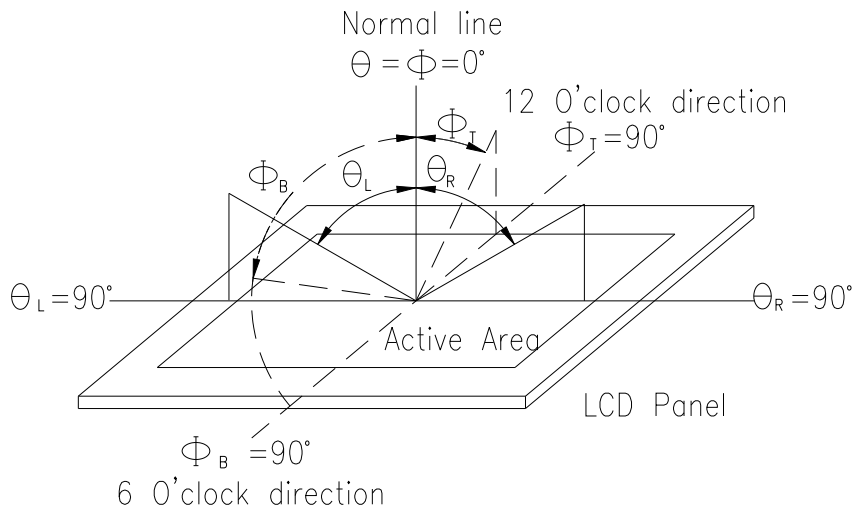

Fig. 8-1 Definition of viewing angle

Note 2: Test equipment setup:

After stabilizing and leaving the panel alone at a driven temperature for 10 minutes, the measurement should be executed. Measurement should be executed in a stable, windless, and dark room. Optical specifications are measured by Topcon BM-7 or BM-5 luminance meter 1.0° field of view at a distance of 50cm and normal direction.

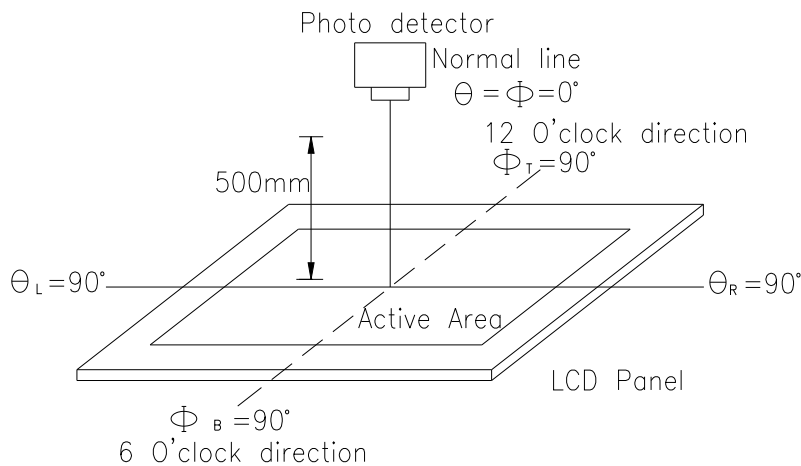
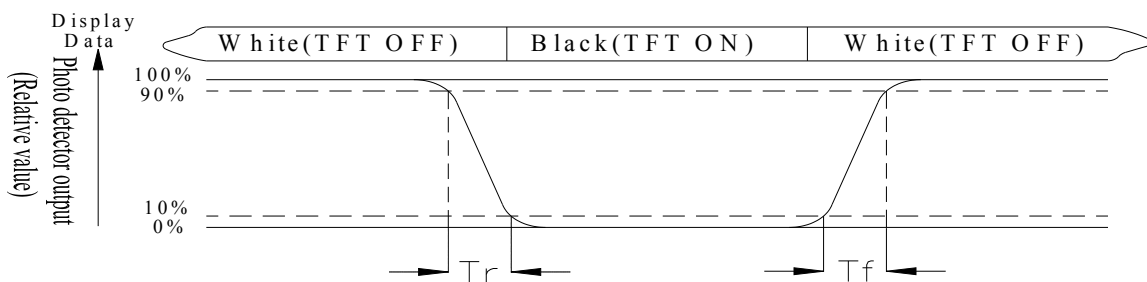

Fig. 8-2 Optical measurement system setup

Note 3: Definition of Response time:

The response time is defined as the LCD optical switching time interval between “White” state and “Black” state. Rise time, T_r , is the time between photo detector output intensity changed from 90% to 10%. And fall time, T_f , is the time between photo detector output intensity changed from 10% to 90%



Note 4: Definition of contrast ratio:

The contrast ratio is defined as the following expression.

$$\text{Contrast ratio (CR)} = \frac{\text{Luminance measured when LCD on the "White" state}}{\text{Luminance measured when LCD on the "Black" state}}$$

Note 5: White $V_i = V_{i50} \pm 1.5V$

Black $V_i = V_{i50} \pm 2.0V$

“±” means that the analog input signal swings in phase with VCOM signal.

“±” means that the analog input signal swings out of phase with VCOM signal.

The 100% transmission is defined as the transmission of LCD panel when all the input terminals of module are electrically opened.

Note 6: Definition of color chromaticity (CIE 1931)

Color coordinates measured at the center point of LCD

Note 7: Measured at the center area of the panel when all the input terminals of LCD panel are electrically opened.

9. Interface

9.1. LCM PIN Definition

Pin	Symbol	Function	Remark
1	GND	System ground pin of the IC. Connect to system ground.	
2	VCC	Power Supply : +3.3V	
3	NC	No connect	
4	D/C	Data/Command select	
5	WR	Write strobe signal	
6	RD	Read strobe signal	
7	DB0	Data bus	
8	DB1	Data bus	
9	DB2	Data bus	
10	DB3	Data bus	
11	DB4	Data bus	
12	DB5	Data bus	
13	DB6	Data bus	
14	DB7	Data bus	
15	DB8	Data bus	
16	DB9	Data bus	
17	DB10	Data bus	

18	DB11	Data bus	
19	DB12	Data bus	
20	DB13	Data bus	
21	DB14	Data bus	
22	DB15	Data bus	
23	NC	No connect	
24	NC	No connect	
25	CS	Chip select	
26	RST	Hardware reset	
27	RL	Left /right selection	
28	UD	Up/down selection	
29	NC	No connect	
30	NC	No connect	
31	NC	No connect	
32	NC	No connect	

10. Block Diagram

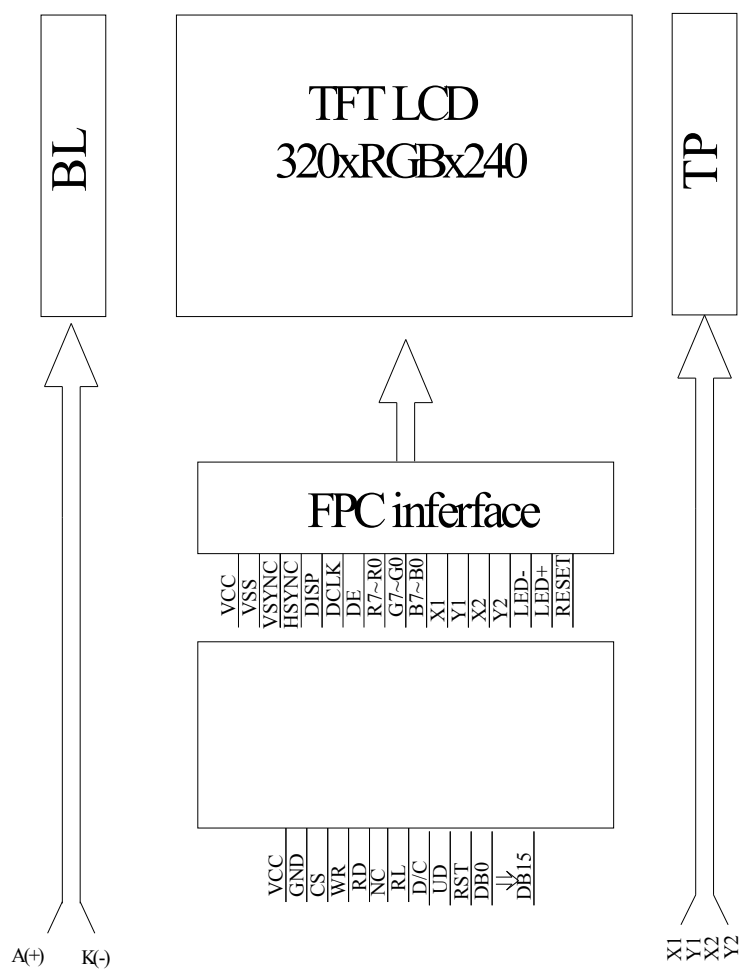

11. Reliability

Content of Reliability Test (Wide temperature, -20°C~70°C)

Environmental Test			
Test Item	Content of Test	Test Condition	Note
High Temperature storage	Endurance test applying the high storage temperature for a long time.	80°C 200hrs	2
Low Temperature storage	Endurance test applying the high storage temperature for a long time.	-30°C 200hrs	1,2
High Temperature Operation	Endurance test applying the electric stress (Voltage & Current) and the thermal stress to the element for a long time.	70°C 200hrs	—
Low Temperature Operation	Endurance test applying the electric stress under low temperature for a long time.	-20°C 200hrs	1
High Temperature/ Humidity Operation	The module should be allowed to stand at 60°C, 90%RH max For 96hrs under no-load condition excluding the polarizer, Then taking it out and drying it at normal temperature.	60°C, 90%RH 96hrs	1,2
Thermal shock resistance	The sample should be allowed stand the following 10 cycles of operation <div style="text-align: center;"> <p style="text-align: center;">-20°C 25°C 70°C</p> <p style="text-align: center;"> </p> <p style="text-align: center;">30min 5min 30min</p> <p style="text-align: center;">1 cycle</p> </div>	-20°C/70°C 10 cycles	—
Vibration test	Endurance test applying the vibration during transportation and using.	Total fixed amplitude : 15mm Vibration Frequency : 10~55Hz One cycle 60 seconds to 3 directions of X,Y,Z for Each 15 minutes	3
Static electricity test	Endurance test applying the electric stress to the terminal.	VS=800V, RS=1.5kΩ CS=100pF 1 time	—

Note1: No dew condensation to be observed.

Note2: The function test shall be conducted after 4 hours storage at the normal Temperature and humidity after remove from the test chamber.

Note3: Vibration test will be conducted to the product itself without putting it in a container.

12. Touch Panel Information

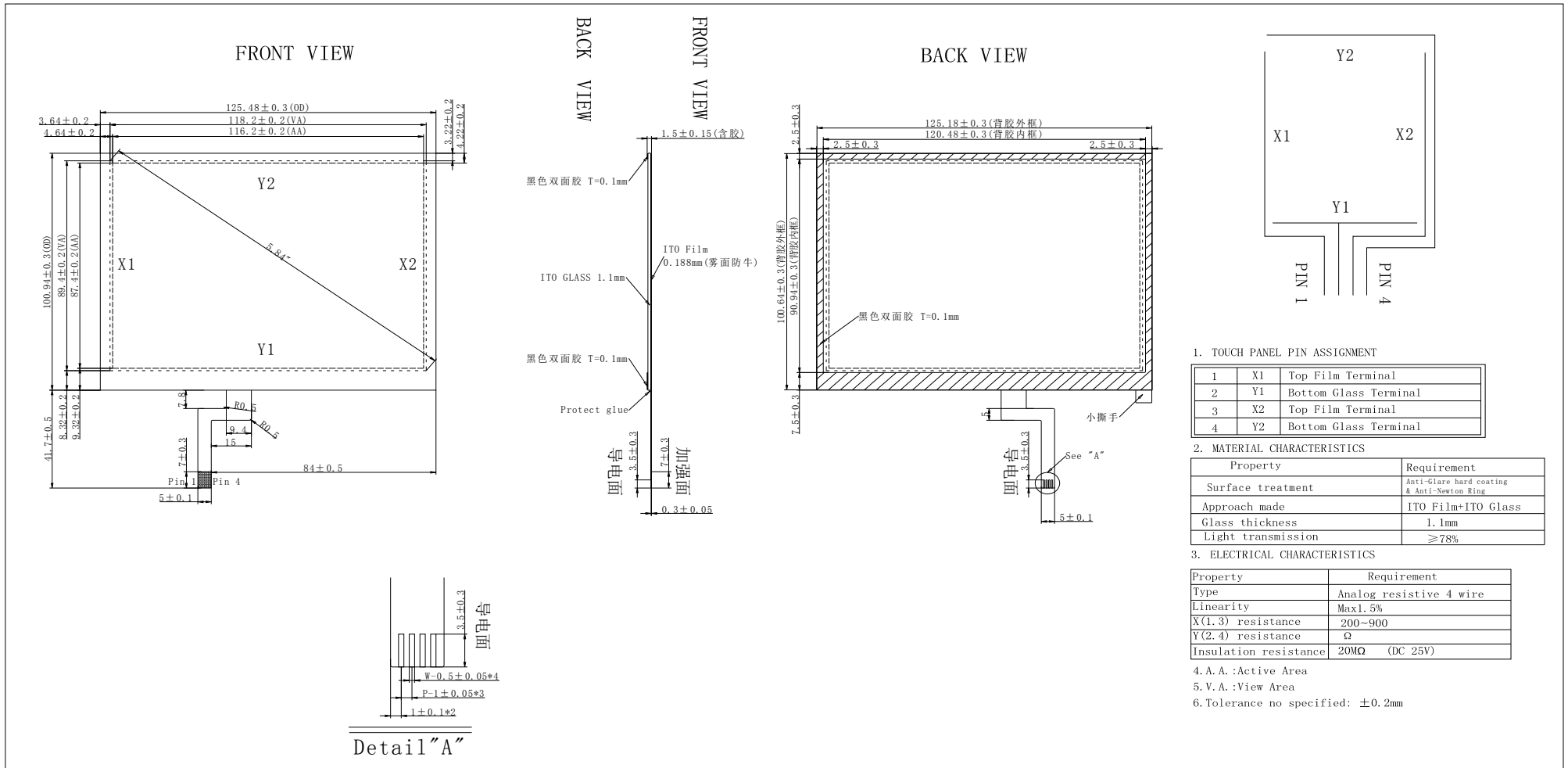

13. Contour Drawing

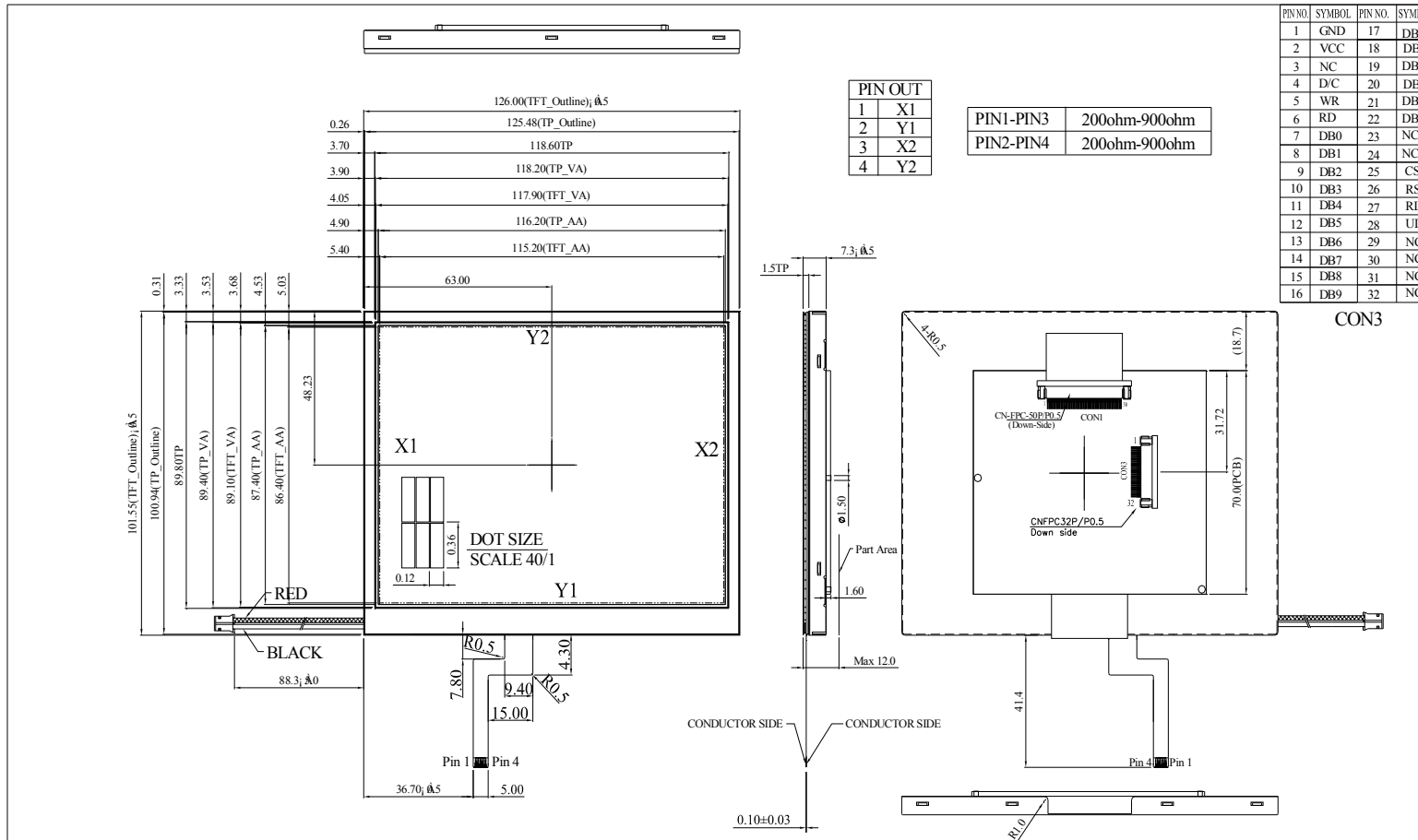

PIN OUT	
1	X1
2	Y1
3	X2
4	Y2

PIN1-PIN3	200ohm-900ohm
PIN2-PIN4	200ohm-900ohm

PIN NO.	SYMBOL	PIN NO.	SYMBOL
1	GND	17	DB10
2	VCC	18	DB11
3	NC	19	DB12
4	D/C	20	DB13
5	WR	21	DB14
6	RD	22	DB15
7	DB0	23	NC
8	DB1	24	NC
9	DB2	25	CS
10	DB3	26	RST
11	DB4	27	RL
12	DB5	28	UD
13	DB6	29	NC
14	DB7	30	NC
15	DB8	31	NC
16	DB9	32	NC

1	Lcd Type	TFT
2	Gray Scale Inversion Direction	6 o'clock
3	screen size	5.7(diagonal)
4	Number of Pixels	320x3(RGB)x240
5	Operating Temperature	-20°C ~70°C
6	Storage Temperature	-30°C ~80°C
7	pixel configuration	RGB-STRIP
8	Brightness	(320cd/m2 TYP)

SCALE:	1/1	UNIT:	mm	È Á ě a Š É Ů Ď ě ¾ WINSTAR DISPLAY CO.
REV:	0	PAGE:	1/1	
APPROVE		MODEL	WF57DTIBCDBT0#	
CHECK		TITLE	LCM DRAWING	
DRAW	Xujia 2013.05.02	DWG NO.	T-020458	

14. Package Specification

LCM Model	WF57DTIBCDBT0#	LCM 包裝規格書 LCM Packaging Specifications	Approve	Check	Contact
Drawing NO.			DATE	初版	版次 Ver
			13'7/2	13'7/2	0

1. 包裝材料規格表 (Packaging Material) :(per carton)

NO.	Item	Model	Dimensions	Quantity
1	成品 (LCM)	WF57DTIBCDBT0#	126mm*101.55mm * 12.0mm	60
2	TRAY 盤 (2)	PKCA1XXXXXXXXXXXX0291	315mm*265mm	30
3	BP01 內盒(3)Product Box	PK3R1XXXXXXXXXXXX0001	332*280*100mm	6
4	泡棉(4)Foam	-----	283*230*8mm	6
5	外紙箱(5)Carton	PK4Q1XXXXXXXXXXXX0000	565*340*320mm	1
6				
7				
8				
9				

2. 單箱數量規格表(Packaging Specifications and Quantity) :

(1) LCM quantity per box : no per tray 2 x no of tray 5 = 10

(2) Total LCM quantity in carton : quantity per box 10 x no of boxes 6 = 60

特 記 事 項 (REMARK)

<p>1. Label Specifications :</p> <table border="1" style="width:100%; height: 40px;"> <tr> <td style="padding: 2px;">MOOEL:</td> </tr> <tr> <td style="padding: 2px;">LOT NO :</td> </tr> <tr> <td style="padding: 2px;">QUANTITY:</td> </tr> <tr> <td style="padding: 2px;">CHECK:</td> </tr> </table>	MOOEL:	LOT NO :	QUANTITY:	CHECK:	
MOOEL:					
LOT NO :					
QUANTITY:					
CHECK:					

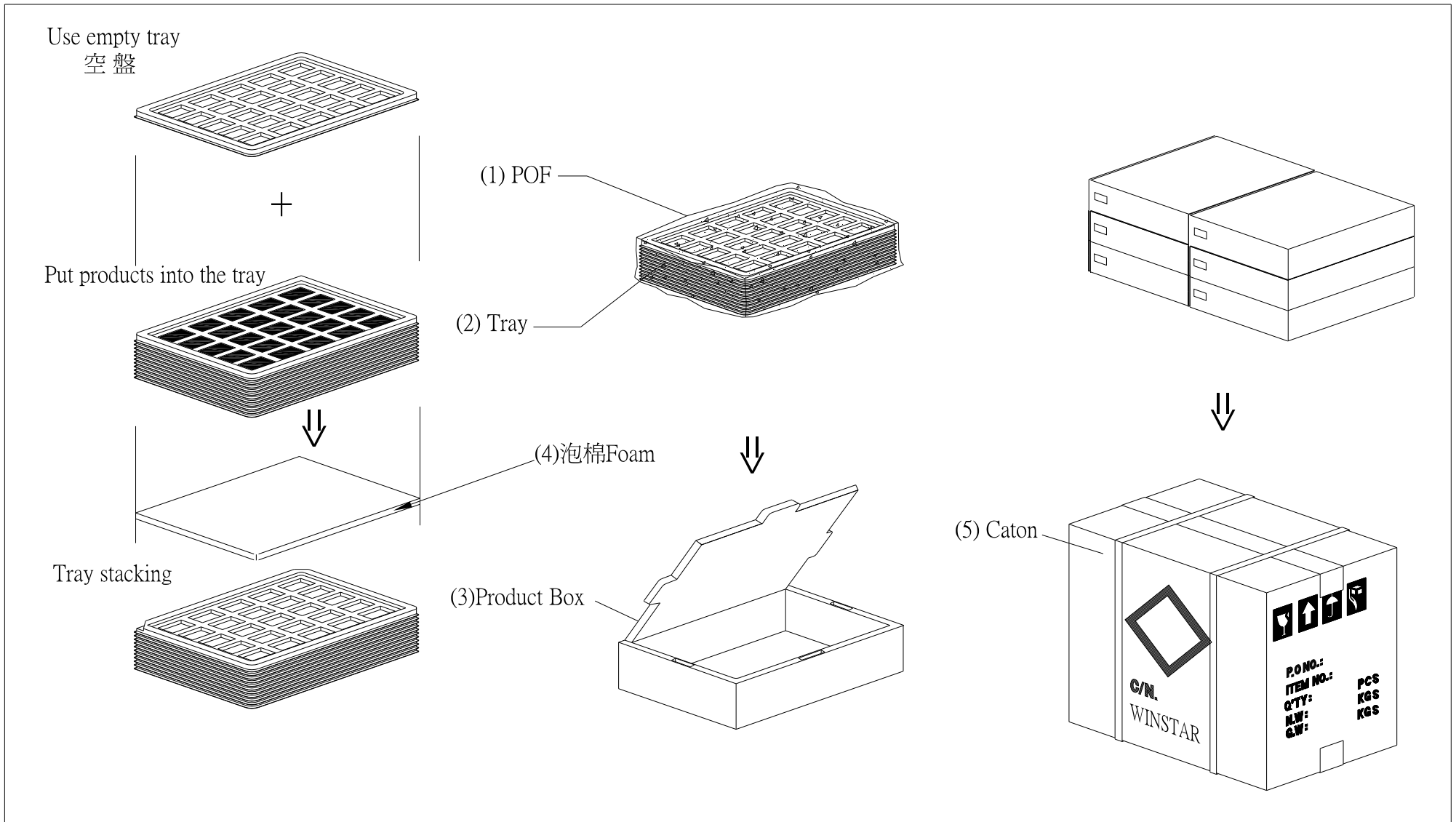

15. Initial Code For Reference

```
void Initial_SSD1963()
```

```
{
```

```
    Write_Command(0x01);
```

```
    Delay_ms(10);
```

```
    Write_Command(0xe0);
```

```
    Write_Parameter(0x01);
```

```
    Delay_ms(5);
```

```
    Write_Command(0xe0);
```

```
    Write_Parameter(0x03);
```

```
    Delay_ms(5);
```

```
    Write_Command(0xb0);
```

```
    Write_Parameter(0x0c);
```

```
    Write_Parameter(0x80);
```

```
    Write_Parameter(0x01);
```

```
    Write_Parameter(0x3f);
```

```
    Write_Parameter(0x00);
```

```
    Write_Parameter(0xef);
```

```
    Write_Parameter(0x00);
```

```
    Write_Command(0xf0);
```

```
    Write_Parameter(0x00);
```

```
    Write_Command(0x3a);
```

```
    Write_Parameter(0x60);
```

```
    Write_Command(0xe2);
```

```
    Write_Parameter(0x1d);
```

```
    Write_Parameter(0x02);
```

```
    Write_Parameter(0x54);
```

```
    Write_Command(0xe6);
```

```
    Write_Parameter(0x01);
```

```
    Write_Parameter(0x40);
```

```
    Write_Parameter(0xff);
```

```
    Write_Command(0xb4);
```

```
    Write_Parameter(0x01);
```

Write_Parameter(0xb8);
Write_Parameter(0x00);
Write_Parameter(0x44);
Write_Parameter(0x07);
Write_Parameter(0x00);
Write_Parameter(0x00);
Write_Parameter(0x00);

Write_Command(0xb6);
Write_Parameter(0x01);
Write_Parameter(0x08);
Write_Parameter(0x00);
Write_Parameter(0x13);
Write_Parameter(0x07);
Write_Parameter(0x00);
Write_Parameter(0x00);

Write_Command(0x2a);
Write_Parameter(0x00);
Write_Parameter(0x00);
Write_Parameter(0x01);
Write_Parameter(0x3f);

Write_Command(0x2b);
Write_Parameter(0x00);
Write_Parameter(0x00);
Write_Parameter(0x00);
Write_Parameter(0xef);

Write_Command(0x29);
Write_Command(0x2c);

}



Module Number : _____

Page: 1

1、Panel Specification :

- 1. Panel Type : Pass NG , _____
- 2. View Direction : Pass NG , _____
- 3. Numbers of Dots : Pass NG , _____
- 4. View Area : Pass NG , _____
- 5. Active Area : Pass NG , _____
- 6. Operating Temperature : Pass NG , _____
- 7. Storage Temperature : Pass NG , _____
- 8. Others : _____

2、Mechanical Specification :

- 1. PCB Size : Pass NG , _____
- 2. Frame Size : Pass NG , _____
- 3. Material of Frame : Pass NG , _____
- 4. Connector Position : Pass NG , _____
- 5. Fix Hole Position : Pass NG , _____
- 6. Backlight Position : Pass NG , _____
- 7. Thickness of PCB : Pass NG , _____
- 8. Height of Frame to PCB : Pass NG , _____
- 9. Height of Module : Pass NG , _____
- 10. Others : Pass NG , _____

3、Relative Hole Size :

- 1. Pitch of Connector : Pass NG , _____
- 2. Hole size of Connector : Pass NG , _____
- 3. Mounting Hole size : Pass NG , _____
- 4. Mounting Hole Type : Pass NG , _____
- 5. Others : Pass NG , _____

4、Backlight Specification :

- 1. B/L Type : Pass NG , _____
- 2. B/L Color : Pass NG , _____
- 3. B/L Driving Voltage (Reference for LED Type) : Pass NG , _____
- 4. B/L Driving Current : Pass NG , _____
- 5. Brightness of B/L : Pass NG , _____
- 6. B/L Solder Method : Pass NG , _____
- 7. Others : Pass NG , _____

>> **Go to page 2** <<



Module Number : _____

Page: 2

5、Electronic Characteristics of Module :

- | | | |
|------------------------------|-------------------------------|-------------------------------------|
| 1. Input Voltage : | <input type="checkbox"/> Pass | <input type="checkbox"/> NG , _____ |
| 2. Supply Current : | <input type="checkbox"/> Pass | <input type="checkbox"/> NG , _____ |
| 3. Driving Voltage for LCD : | <input type="checkbox"/> Pass | <input type="checkbox"/> NG , _____ |
| 4. Contrast for LCD : | <input type="checkbox"/> Pass | <input type="checkbox"/> NG , _____ |
| 5. B/L Driving Method : | <input type="checkbox"/> Pass | <input type="checkbox"/> NG , _____ |
| 6. Negative Voltage Output : | <input type="checkbox"/> Pass | <input type="checkbox"/> NG , _____ |
| 7. Interface Function : | <input type="checkbox"/> Pass | <input type="checkbox"/> NG , _____ |
| 8. LCD Uniformity : | <input type="checkbox"/> Pass | <input type="checkbox"/> NG , _____ |
| 9. ESD test : | <input type="checkbox"/> Pass | <input type="checkbox"/> NG , _____ |
| 10. Others : | <input type="checkbox"/> Pass | <input type="checkbox"/> NG , _____ |

6、Summary :

Sales signature : _____

Customer Signature : _____

Date : _____ / _____ / _____