



LB1889, 1889M, 1889D

3-phase Brushless Motor Driver for VTR Capstans

Functions

- 3-phase full-wave current linear drive system
- Torque ripple correction circuit built in (variable compensation ratio)
- Current limiting circuit built in/with control characteristic gain switch
- Output stage upper/lower oversaturation prevention circuit built in (no external capacitor required)
- FG amplifier built in
- Thermal shutdown circuit built in

Package Dimensions

unit : mm

3206-QFP34H

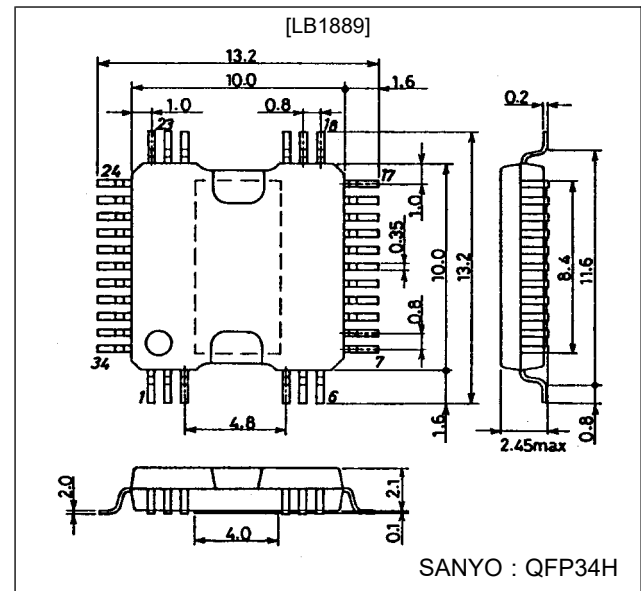

3147A-DIP28HS

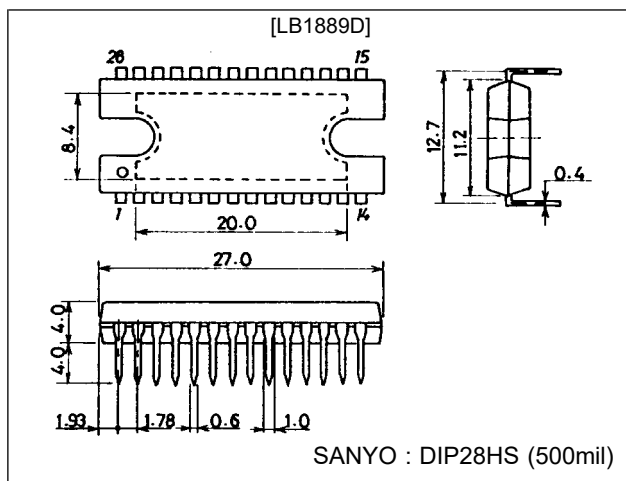

3129-MFP36S

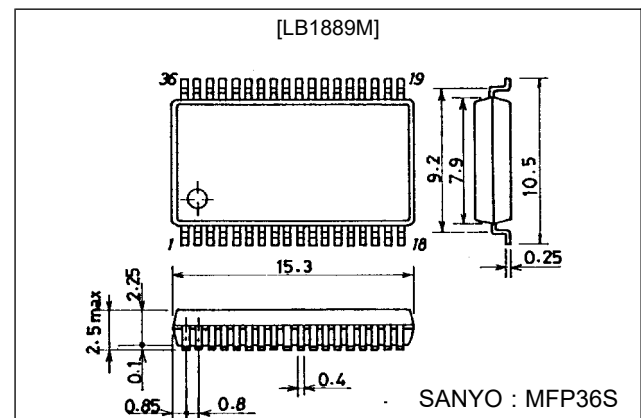

LB1889, 1889M, 1889D

Specifications

Absolute Maximum Ratings at $T_a = 25\text{ }^\circ\text{C}$

Parameter	Symbol	Conditions	Ratings	Unit
Maximum supply voltage	V_{CC} max		7	V
	V_S max		24	V
Maximum output current	I_O max		1.3	A
Allowable power dissipation	Pd max	Arbitrarily large heat sink LB1889	12.5	W
		Arbitrarily large heat sink LB1889D	15.0	W
		Independent IC LB1889	0.77	W
		Independent IC LB1889M	0.95	W
		Independent IC LB1889D	3.0	W
Operating temperature	Topr		-20 to +75	$^\circ\text{C}$
Storage temperature	Tstg		-55 to +150	$^\circ\text{C}$

Allowable Operating Ranges at $T_a = 25\text{ }^\circ\text{C}$

Parameter	Symbol	Conditions	Ratings	Unit
Supply voltage	V_S		5 to 22	V
	V_{CC}		4.5 to 5.5	V
Hall input amplitude	V_{HALL}	Between Hall inputs	± 30 to ± 80	mV _{O-P}
GSENSE input range	V_{GSENSE}	Relative to control system GND	-0.20 to +0.20	V

Electrical Characteristics at $T_a = 25\text{ }^\circ\text{C}$, $V_{CC} = 5\text{ V}$, $V_S = 15\text{ V}$

Parameter	Symbol	Conditions	min	typ	max	Unit
V_{CC} supply current	I_{CC}	$R_L = \infty$ (when stopped), $V_{CTL} = 0\text{ V}$, $V_{LIM} = 0\text{ V}$		12	18	mA
[Output]						
Output saturation voltage	V_{Osat1}	$I_O = 500\text{ mA}$, $R_f = 0.5\ \Omega$, Sink + Source $V_{CTL} = V_{LIM} = 5\text{ V}$ (with saturation prevention)		2.1	2.6	V
	V_{Osat2}	$I_O = 1.0\text{ A}$, $R_f = 0.5\ \Omega$, Sink + Source $V_{CTL} = V_{LIM} = 5\text{ V}$ (with saturation prevention)		2.6	3.5	V
Output leakage current	I_{oleak}				1.0	mA
[FR]						
FR pin input threshold voltage	V_{FSR}		2.25	2.50	2.75	V
FR pin input bias current	I_b (FSR)		-5.0			μA
[Control]						
CTLREF pin voltage	V_{CREF}		2.37	2.50	2.63	V
CTLREF pin input range	V_{CREFIN}		1.70		3.50	V
CTL pin input bias current	I_b (CTL)	$V_{CTL} = 5\text{ V}$, CTLREF : Open			8.0	μA
CTL pin control start voltage	V_{CTL} (ST)	With $R_f = 0.5\ \Omega$, $V_{LIM} = 5\text{ V}$, $I_O \geq 10\text{ mA}$, Hall input logic fixed, (u, v, w = H, H, L)	2.20	2.35	2.50	V
CTL pin control switch voltage	V_{CTL} (ST2)	$R_f = 0.5\ \Omega$, $V_{LIM} = 5\text{ V}$	3.00	3.15	3.30	V
CTL pin control Gm1	Gm1 (CTL)	With $R_f = 0.5\ \Omega$, $\Delta I_O = 200\text{ mA}$, Hall input logic fixed, (u, v, w = H, H, L)	0.52	0.65	0.78	A/V
CTL pin control Gm2	Gm2 (CTL)	With $R_f = 0.5\ \Omega$, $\Delta V_{CTL} = 200\text{ mV}$, Hall input logic fixed, (u, v, w = H, H, L)	1.20	1.50	1.80	A/V
[Current Limit]						
LIM current limit offset voltage	V_{off} (LIM)	With $R_f = 0.5\ \Omega$, $V_{CTL} = 5\text{ V}$, $I_O \geq 10\text{ mA}$, Hall input logic fixed, (u, v, w = H, H, L)	140	200	260	mV
LIM pin input bias current	I_b (LIM)	With $V_{CTL} = 5\text{ V}$, CTLREF : Open, $V_{LIM} = 0\text{ V}$	-2.5			μA
LIM pin current limit level	I_{lim}	With $R_f = 0.5\ \Omega$, $V_{CTL} = 5\text{ V}$, $V_{LIM} = 2.06\text{ V}$, Hall input logic fixed, (u, v, w = H, H, L)	830	900	970	mA
[Hall Amplifier]						
Hall amplifier input offset voltage	V_{off} (HALL)		-6		+6	mV
Hall amplifier input bias current	I_b (HALL)			1.0	3.0	μA
Hall amplifier common-mode input voltage	V_{cm} (HALL)		1.3		3.3	V

Continued on next page.

LB1889, 1889M, 1889D

Continued from preceding page.

Parameter	Symbol	Conditions	min	typ	max	Unit
[TRC]						
Torque ripple correction factor	T_{RC}	At bottom and peak in Rf waveform at $I_O = 200$ mA (RF = 0.5 Ω , ADJ-OPEN) Note 2		9		%
ADJ pin voltage	V_{adj}		2.37	2.50	2.63	V
[FG Amplifier]						
FG amplifier input offset voltage	V_{off} (FG)		-8		+8	mV
FG amplifier input bias current	I_b (FG)		-100			nA
FG amplifier output saturation voltage	V_{Osat} (FG)	At internal pull-up resistor load on sink side			0.5	V
FG amplifier common-mode input voltage	V_{CM} (FG)		0.5		4.0	V
[Saturation]						
Saturation prevention circuit lower set voltage	V_{Osat} (DET)	Voltage between each OUT and Rf at $I_O = 10$ mA, Rf = 0.5 Ω , $V_{CTL} = V_{LIM} = 5$ V	0.175	0.25	0.325	V
[TSD]						
TSD operation temperature	T-TSD	(Design target) Note 1		180		$^{\circ}$ C
TSD temperature hysteresis width	Δ TSD	(Design target) Note 1		20		$^{\circ}$ C

Note 1: No measurements are performed for any values listed in the conditions column as design targets.

Note 2: The torque ripple correction factor is calculated using the Rf voltage waveform as follows.

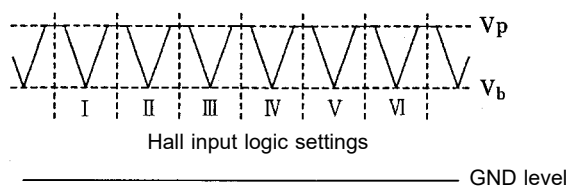

$$\text{Correction factor} = \frac{2 \times (V_p - V_b)}{V_p + V_b} \times 100 (\%)$$

A03956

Truth Table & Control Function

	Source \rightarrow Sink	Hall input			FR
		U	V	W	
1	V \rightarrow W	H	H	L	H
	W \rightarrow V				L
2	U \rightarrow W	H	L	L	H
	W \rightarrow U				L
3	U \rightarrow V	H	L	H	H
	V \rightarrow U				L
4	W \rightarrow V	L	L	H	H
	V \rightarrow W				L
5	W \rightarrow U	L	H	H	H
	U \rightarrow W				L
6	V \rightarrow U	L	H	L	H
	U \rightarrow V				L

Note: "H" in the FR column represents a voltage of 2.75 V or more; "L" represents a voltage of 2.25 V or less.
(At $V_{CC} = 5$ V)

Note: "H" in the Hall input columns represents a state in which "+" has a potential which is higher by 0.01 V or more than that of the "-" phase inputs. Conversely, "L" represents a state in which "+" has a potential which is lower by 0.01 V or more than that of the "-" phase input.

Note: Since 180 $^{\circ}$ energized system is used as the drive system, other phases than the sink and source phases are turned off.

Control Function & Current Limit Function

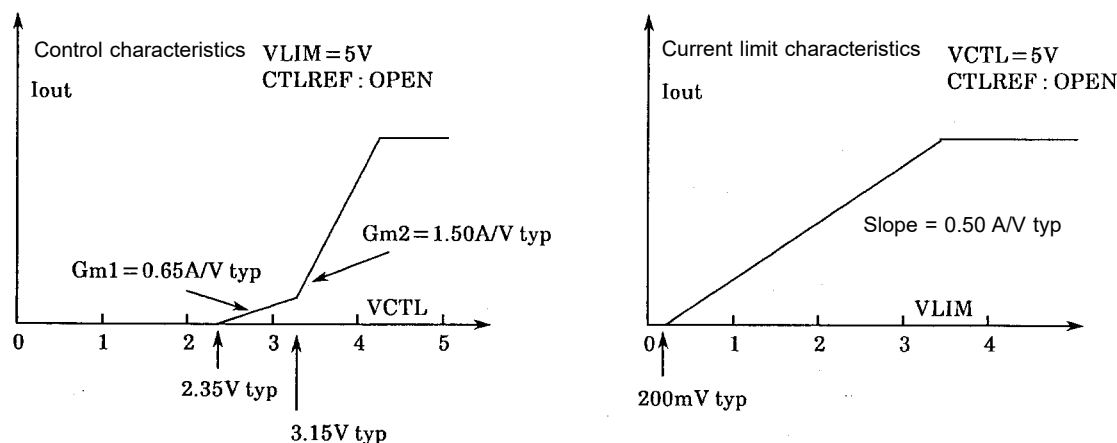

Pin Functions

The pin number in () is for MFP, that in < > is for DIP, and other than these is for QFP.

Pin name	Pin No.	Function
FR	1 (33) <26>	Forward/reverse select pin. The pin voltage selects forward/reverse. ($V_{th} = 2.5 \text{ V typ}$ at $V_{CC} = 5 \text{ V}$)
GND	2 (34) <27>	GND for other than output transistor. Minimum potential of output transistor is at Rf pin.
FGin (-)	5 (3) <28>	Input pin when FG amplifier is used with inverted input. Feedback resistor is connected between this pin and FG-OUT.
FGin (+)	6 (4) <1>	Noninverting input pin when FG amplifier is used with differential input. Internal bias is not applied.
FG-OUT	8 (5) <3>	FG amplifier output pin. Resistive load provided internally.
CTL	9 (6) <4>	Speed control pin. Control is exercised by constant-current drive with current feedback applied from Rf. $G_m = 0.65 \text{ A/V} \ \& \ 1.50 \text{ A/V typ}$ at $R_f = 0.5 \ \Omega$
CTLREF	10 (7) <5>	Control reference voltage pin. The voltage is set internally to approx. $V_{CC}/2$ but this can be varied by applying voltage through a low impedance (input impedance = approx. $2.5 \text{ k}\Omega$).
LIM	11 (8) <6>	Current limiting function control pin. The output current is varied linearly by this pin voltage; slope = 0.5 A/V typ at $R_f = 0.5 \ \Omega$.
FC	12 (9) <7>	Speed control loop frequency characteristic correction pin
Uin+, Uin- Vin+, Vin- Win+, Win-	13, 14 (10, 11) <8, 9> 15, 16 (12, 13) <10, 11> 17, 18 (14, 15) <12, 13>	U-phase Hall device input pin; logic "H" represents $IN+ > IN-$. V-phase Hall device input pin; logic "H" represents $IN+ > IN-$. W-phase Hall device input pin; logic "H" represents $IN+ > IN-$.
VCC	19 (16) <14>	Power supply pin for supplying power to all circuits except output section in IC; this voltage must be stabilized so as to eliminate ripple and noise.
VS	22 (21) <15>	Output selection power supply pin
ADJ	23 (22) <16>	Pin for external adjustment of torque ripple correction factor. When this factor is to be adjusted, a voltage is externally applied to the ADJ pin through a low impedance. If the voltage applied is increased, the factor drops; conversely, if it is reduced, the factor rises. The factor varies between 0 and 2 times that of the open state. (The voltage is set inside to approx. $V_{CC}/2$ internally, and the input impedance is approx. $5 \text{ k}\Omega$.)
Rf (PWR) Rf (SNS)	24 (23) <17> 33 (31) <24>	Output current detection pin. Current feedback is applied to the control section by connecting Rf between this pin and GND. The lower oversaturation prevention circuit and torque ripple correction circuit are activated in accordance with this pin voltage. Since the oversaturation prevention level is set with this voltage, the lower oversaturation prevention effect may deteriorate in the high current range if the Rf value is reduced to an extremely low level. The PWR and SENSE pins must always be connected.
Uout Vout Wout	27 (26) <21> 29 (27) <22> 31 (28) <23>	U-phase output pin V-phase output pin (Built-in spark killer diode) W-phase output pin
GSENSE	34 (32) <25>	GND sensing pin. By connecting this pin to the neighboring GND on the Rf resistor side of the motor GND wire which contains Rf, the effect that GND common impedance exerts on Rf can be eliminated. (This pin must not be left open.)

Block Diagram

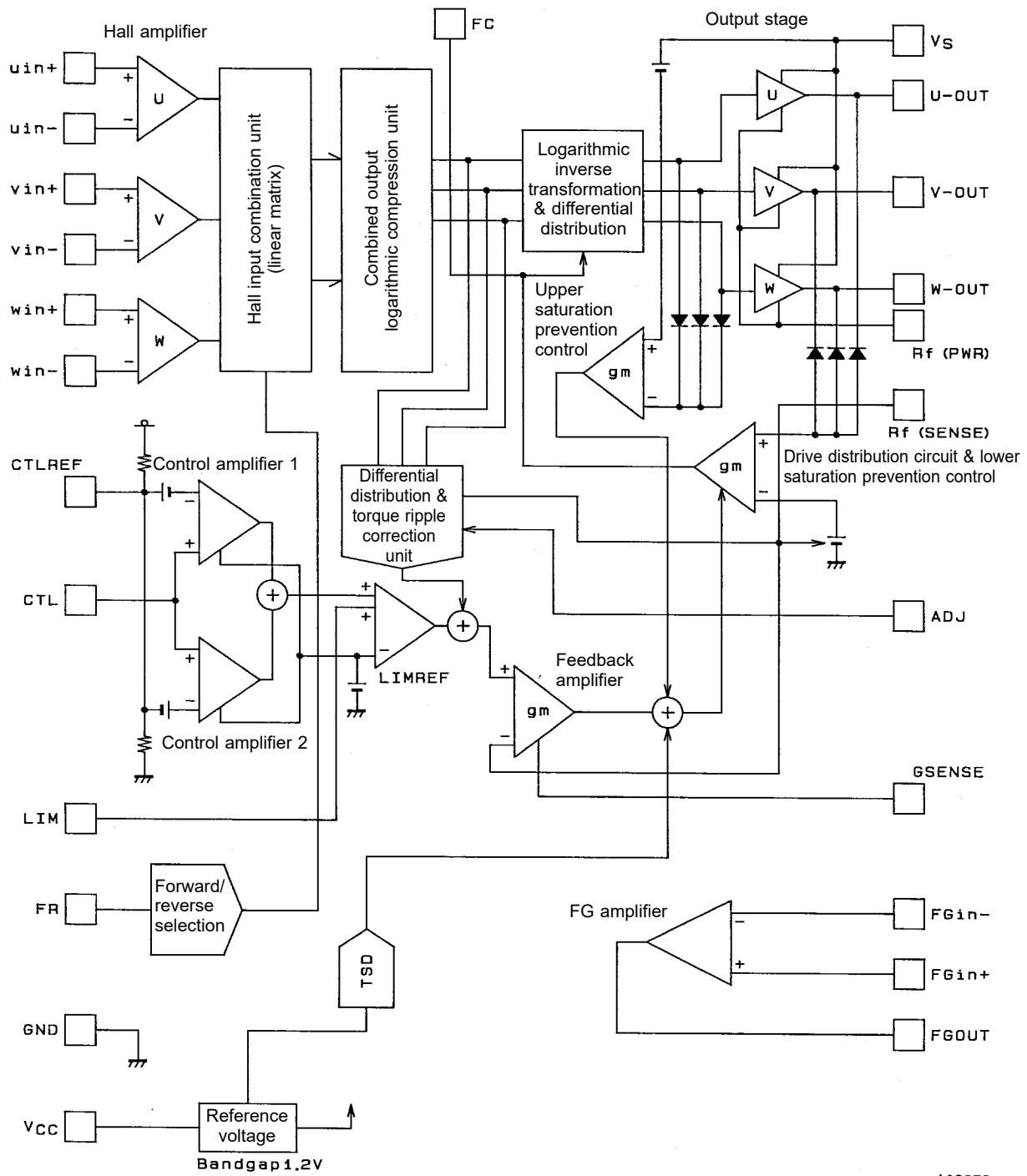

A03959

LB1889, 1889M, 1889D

Pin Assignment [LB1889]

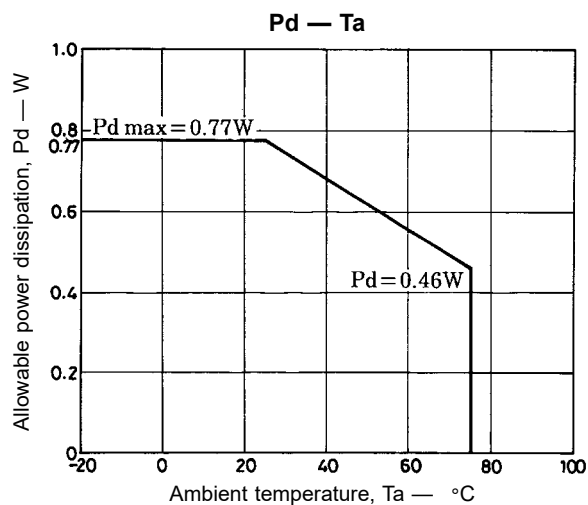
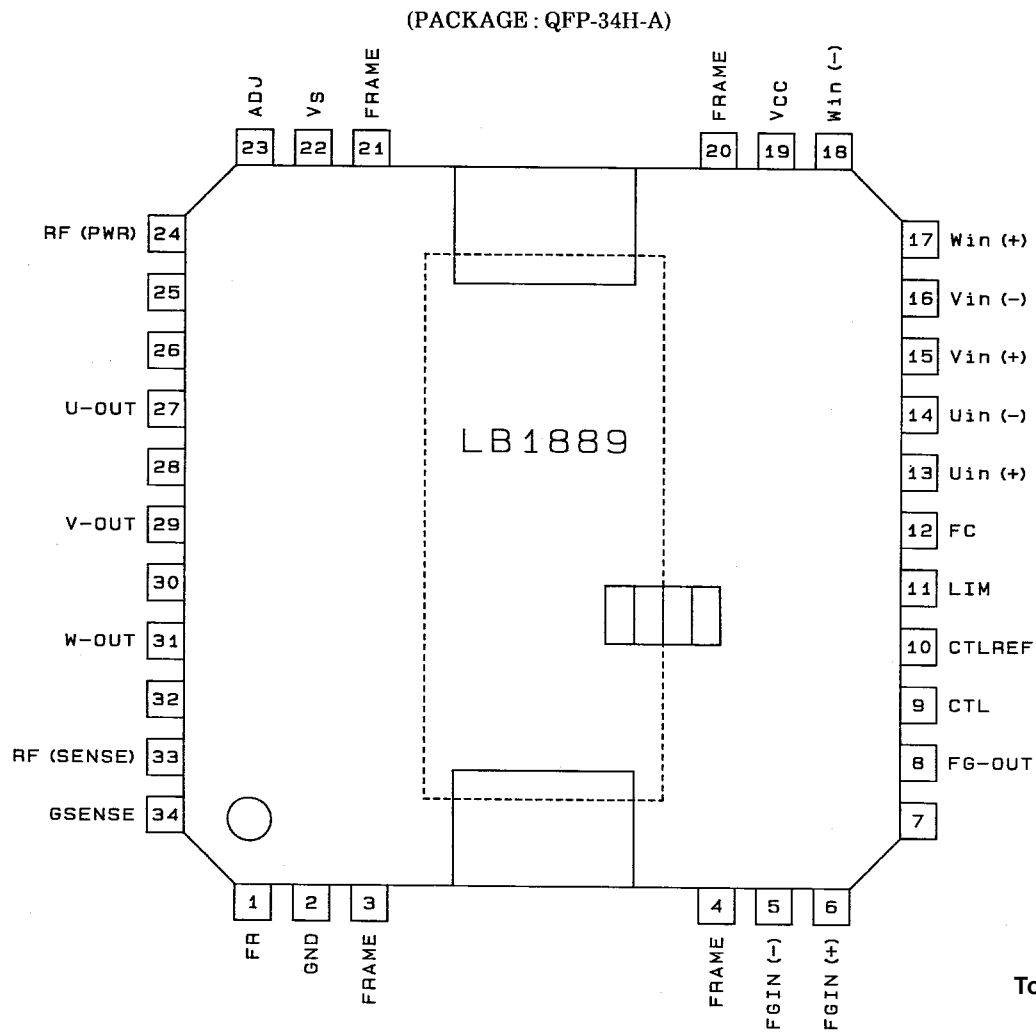

LB1889, 1889M, 1889D

Pin Assignment [LB1889M]

(PACKAGE : MFP-36S-LF)

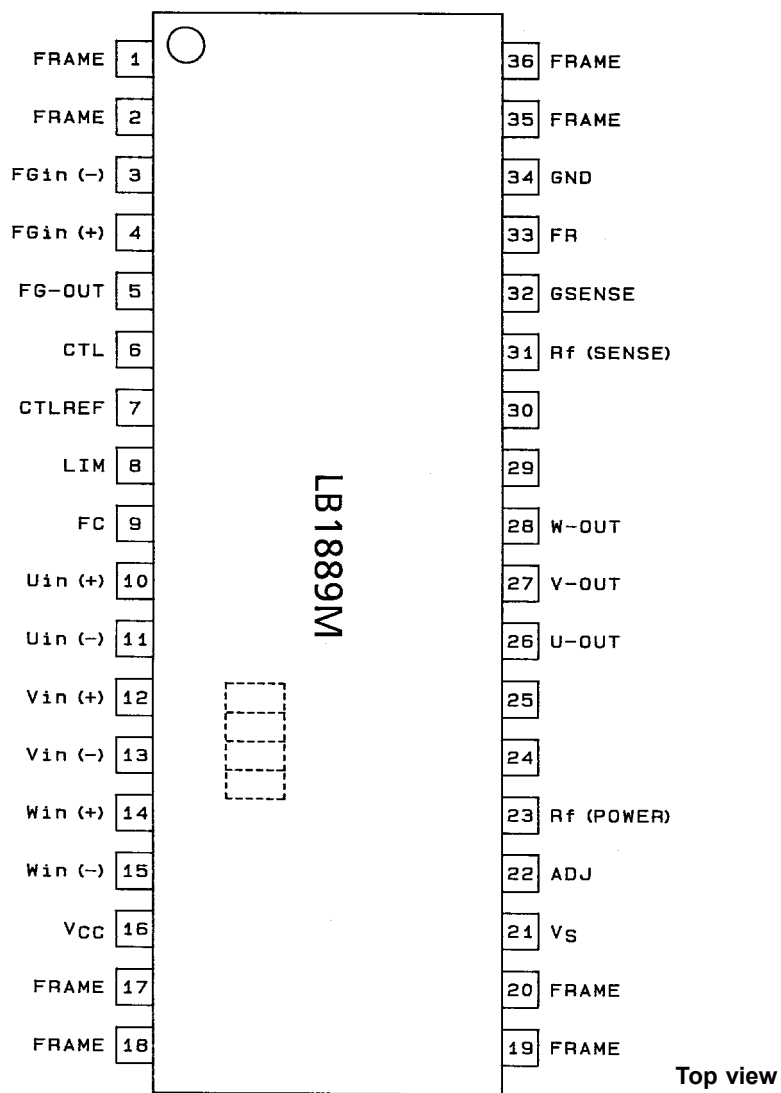

A03961

Note: Although there is no internal connection between the FRAME pin and GND, FRAME must be connected to GND externally for GND potential stabilization.

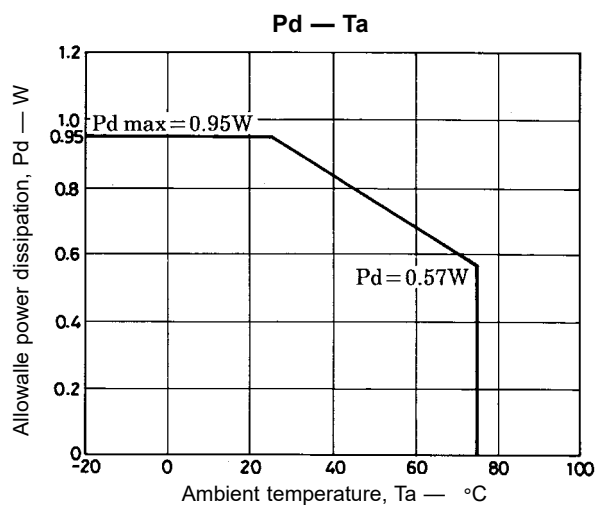

LB1889, 1889M, 1889D

Pin Assignment [LB1889D]

DIP-28HS bent opposite

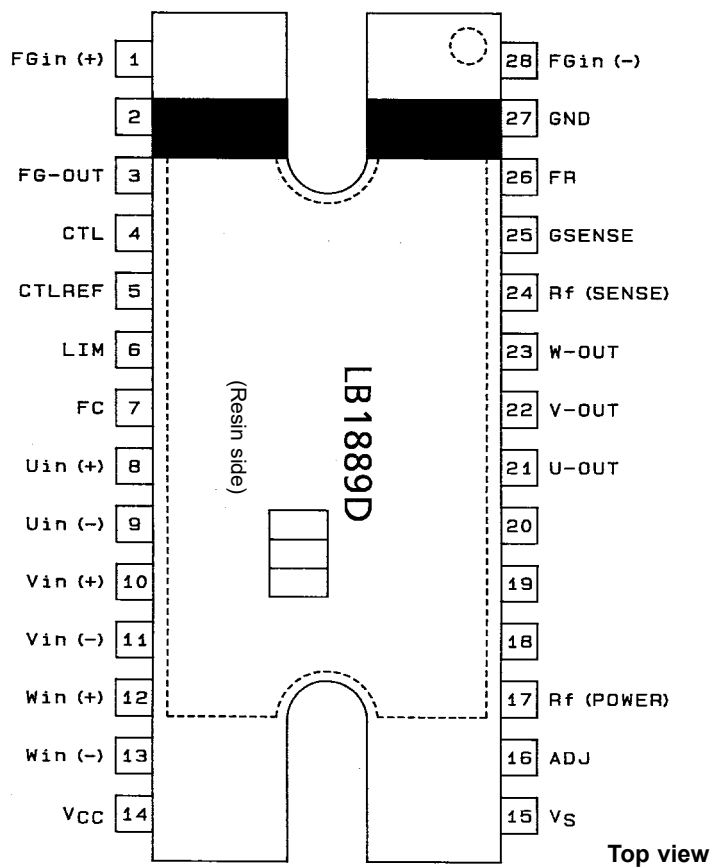

A03962

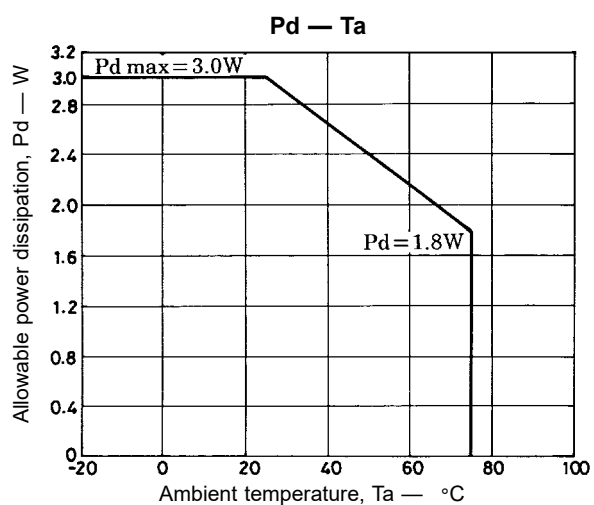

Sample Application Circuit [LB1889]

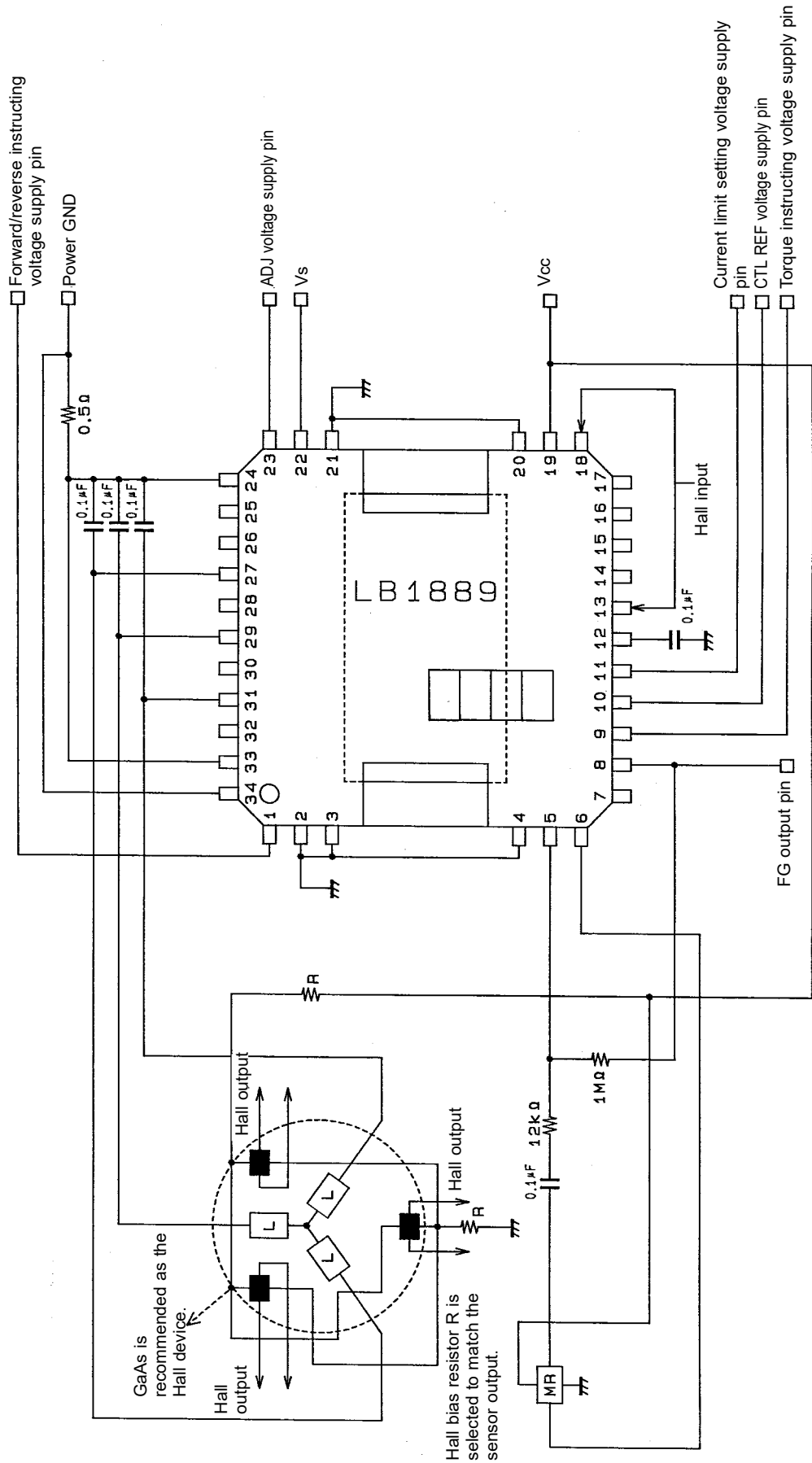

AC3963

Sample Application Circuit [LB1889M]

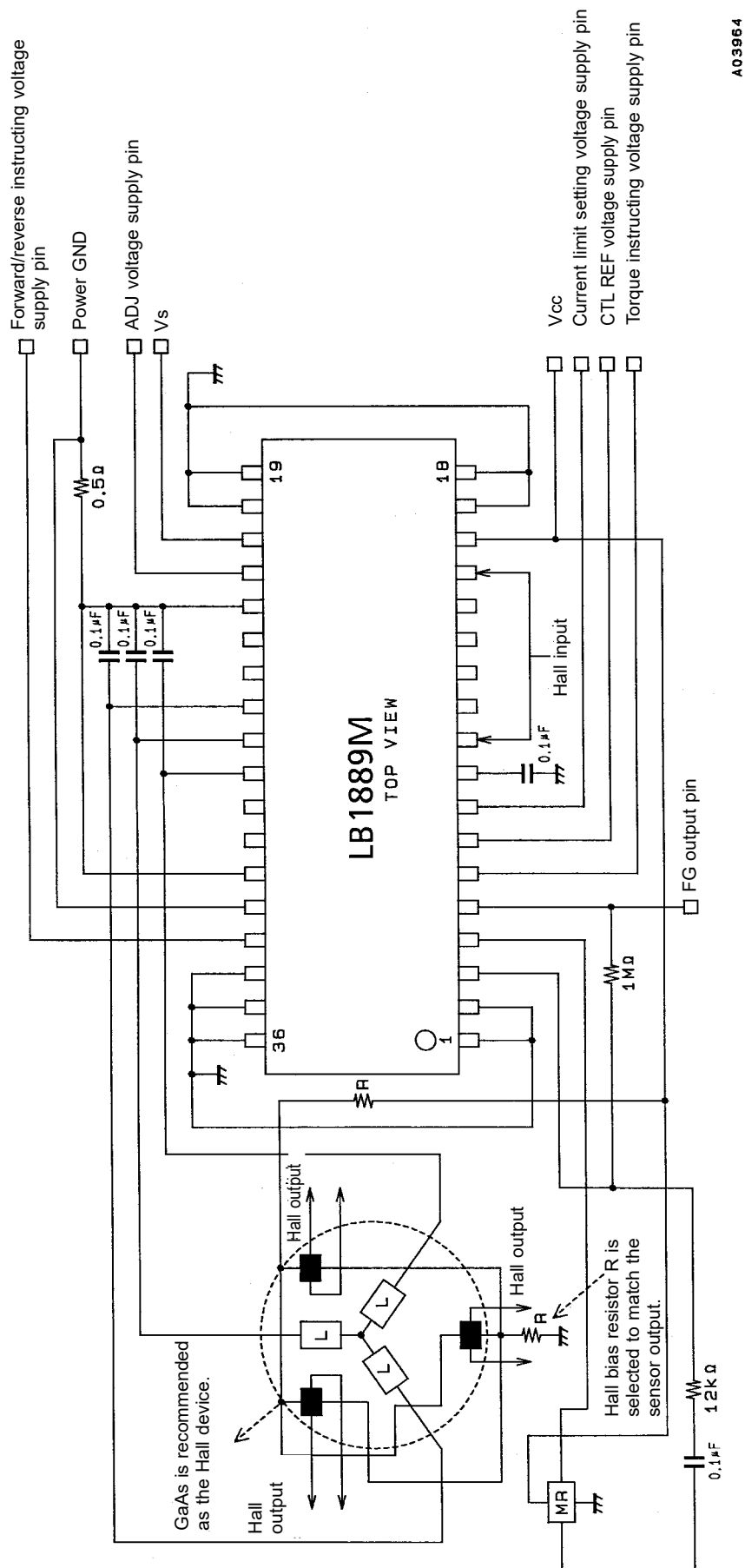

A03964

Note: The constants provided in this sample application circuit are provided by way of example and are not intended to guarantee the characteristics.

Sample Application Circuit [LB1889D]

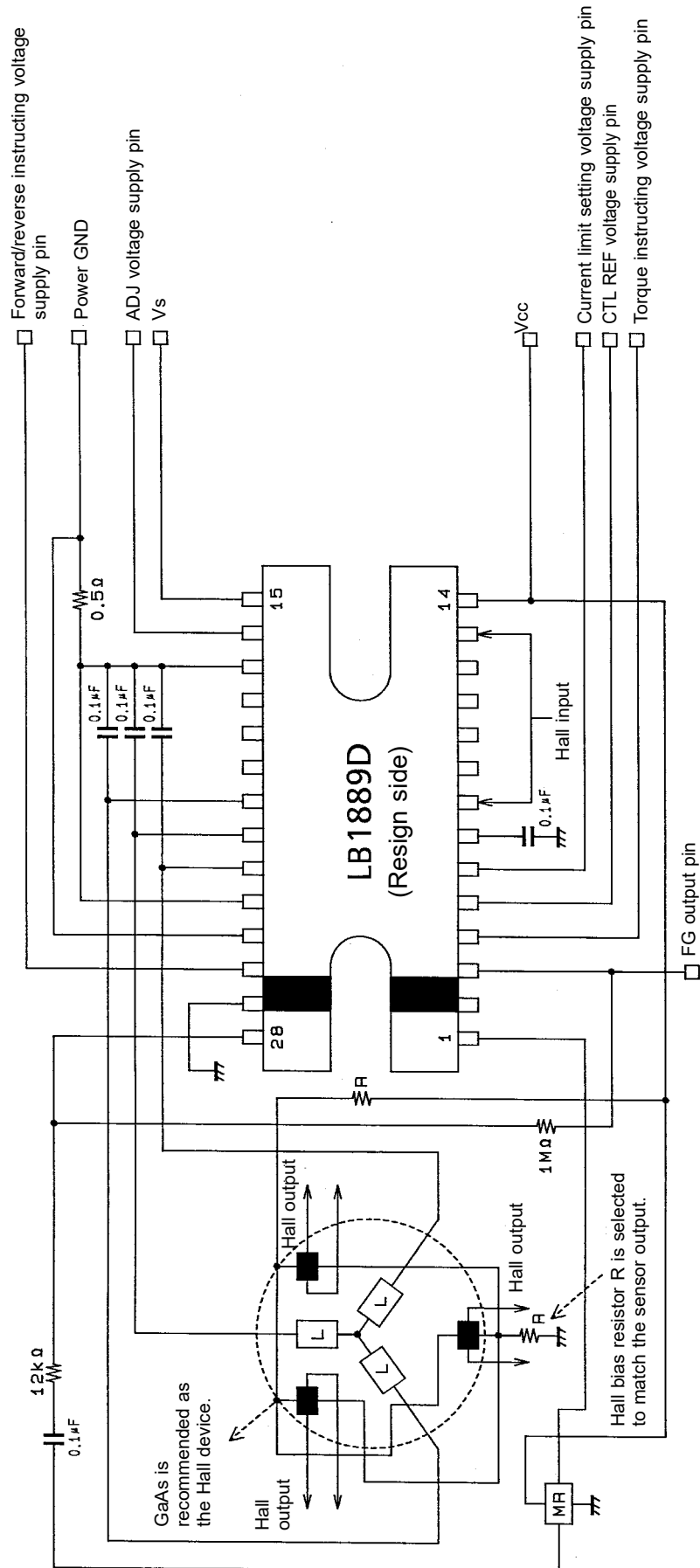

A03965

Note: The constants provided in this sample application circuit are provided by way of example and are not intended to guarantee the characteristics.

LB1889, 1889M, 1889D

Pin Input/Output Equivalent Circuit

Pin name	Input/Output Equivalent Circuit
Uin (+) Uin (-) Vin (+) Vin (-) Win (+) Win (-)	<p style="text-align: center;">Each (+) input Each (-) input</p> <p style="text-align: right;">A03966</p>
U-OUT V-OUT W-OUT Vs Rf (POWER) Rf (SENSE)	<p style="text-align: center;">Each output</p> <p style="text-align: right;">Lower oversaturation prevention circuit input block</p> <p style="text-align: right;">A03967</p>
CTL LIM CTLREF	<p style="text-align: right;">A03968</p>
FR ADJ	<p style="text-align: right;">A03969</p>

Continued on next page.

LB1889, 1889M, 1889D

Continued from preceding page.

Pin name	Input/Output Equivalent Circuit
FGin (-) FGin (+)	<p style="text-align: right;">A03970</p>
FGOUT FC	<p style="text-align: right;">A03971</p>

- No products described or contained herein are intended for use in surgical implants, life-support systems, aerospace equipment, nuclear power control systems, vehicles, disaster/crime-prevention equipment and the like, the failure of which may directly or indirectly cause injury, death or property loss.
- Anyone purchasing any products described or contained herein for an above-mentioned use shall:
 - ① Accept full responsibility and indemnify and defend SANYO ELECTRIC CO., LTD., its affiliates, subsidiaries and distributors and all their officers and employees, jointly and severally, against any and all claims and litigation and all damages, cost and expenses associated with such use:
 - ② Not impose any responsibility for any fault or negligence which may be cited in any such claim or litigation on SANYO ELECTRIC CO., LTD., its affiliates, subsidiaries and distributors or any of their officers and employees jointly or severally.
- Information (including circuit diagrams and circuit parameters) herein is for example only; it is not guaranteed for volume production. SANYO believes information herein is accurate and reliable, but no guarantees are made or implied regarding its use or any infringements of intellectual property rights or other rights of third parties.

This catalog provides information as of September, 1995. Specifications and information herein are subject to change without notice.