

未注公差/General tolerances (mm)													0.1/10	
0	>3	>6	>10	>18	>30	>50	>80	>120	>180	>250	>315	>400		
~3	~6	~10	~18	~30	~50	~80	~120	~180	~250	~315	~400	~500	>500	
±0.12	±0.18	±0.22	±0.26	±0.31	±0.37	±0.57	±0.80	±0.93	±1.05	±1.15	±1.60	±2.20	±2.50	±2'

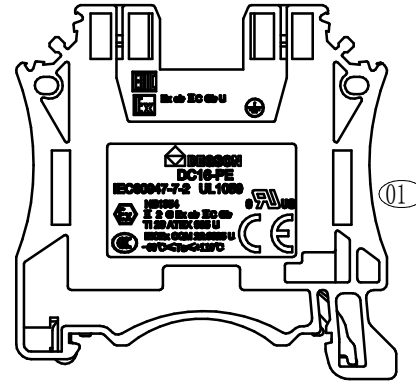
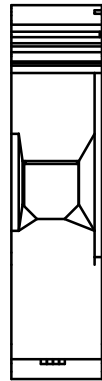
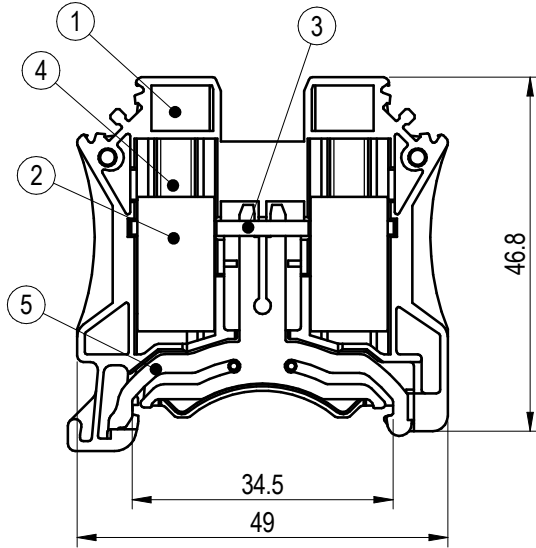
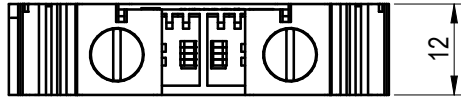

ITEM	NAME OF PART	MATERIAL	NOTES
5	Current contact	Copper alloy	Sn Plated
4	Screw	Stainless steel	M5
3	Current carrier	Copper	Sn Plated
2	Cage	Copper alloy	Ni Plated(2-4um)
1	Housing	PA66	UL94V-0

UL 标准/UL Standard:	B	C	D
额定电压/电流/Rated Voltage(V)/Current(A)	/	/	/
IEC 标准/IEC Standard:			
过压类别/Overtoltage Category/污染等级/Pollution Degree	III/3	III/2	II/2
额定电压/电流/Rated Voltage(V)/Current(A)	/	/	/
额定脉冲电压(KV)/Rate Impulse Voltage(KV)	8	/	/
螺丝扭矩/Torque Tightening(N·m/Lb.in)	M5, 2.5/27		
线径范围(硬线和软线)/Wire Range(rigid and flexible)(AWG mm <sup>2</sup> )	14~ 3/ 1.5~ 25		
间距/Pitch(mm)/线数范围/Poles	12/01P		
剥线长度/Stripping length(mm)	12~ 13		
使用温度范围/Operating temperature(°C)	-40~ + 105		
符合RoHS环保要求/Conform to RoHS	Yes		

		MATERIAL:	SURFACE/COLOR:		
APPD: Peng M 2024.01.30		MAT NO./REV: 11020000291-1 / 00		MAT STATUS: 批量	
CHKD: Gao WG 2024.01.30		NAME			
DRFT: Deng L 2024.01.30		DC16-PE-Cu-01P-1C-200A(H)			
DRAWING NO.	TYPE	DRAWING STATUS	SCALE	SHEET	
200087553	CUSTOMER DRAWING	已发布	1:1	1/1	

REV	ECN	DESCRIPTION	DRFT	DATE
01		Add 3C and explosion-proof mark	Deng L	2024.01.30

Transfer or duplication of this document as well as the utilization or communication of its contents are prohibited unless and until authorization is granted. All rights reserved for patent, utility model or design registrations. 除专利、实用新型、外观设计、发明专利、软件著作权、集成电路布图设计专有权、商业秘密等权利外，本公司保留对外的所有权利。