

TONE/PULSE DIALER WITH REDIAL

The KS5820 is a DTMF/PULSE switchable dialer with a 32-digit redial memory. Through pin selection, switching from pulse to DTMF mode can be done using a slide switch. All necessary dual-tone frequencies are derived from a 3.579545MHz TV crystal, providing very high accuracy and stability. The required sinusoidal wave form for each individual tone is digitally synthesized on the chip. The wave form so generated has very low total harmonic distortion (7% Max). A voltage reference is generated on the chip which is stable over the operating voltage and temperature range and regulates the single levels of the dual tone to meet telephone industry specifications. CMOS technology is applied to this device, for very low power requirements high noise immunity, and easy interface to a variety of telephones requiring external components.

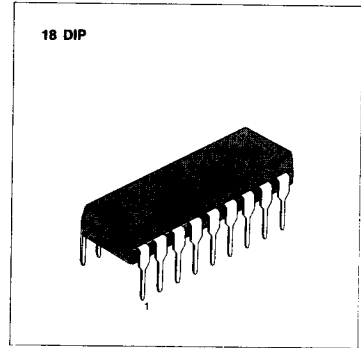

FEATURES

- Tone/Pulse switchable (slide switch).
- 32 digit capacity for redial
- Automatic mix redialing (last number dial) of PULSE → DTMF with multiple auto access pause
- PABX auto-pause for 3.5 sec.
- 4 × 4 or (2 of 8) keyboard available
- Low power CMOS process (2.0 to 5.5V)
- Numbers dialed manually after redial are cascaded and stored as additional numbers for next redialing
- Uses inexpensive TV crystal (3.579545MHz)
- Make/Break ratio (33 1/3 ~ 66 2/3 or 40/60) pin selectable
- Touch key hooking (604ms)
- Low standby current

ORDERING INFORMATION

Device	Dial Pulse	PPS	Make/Break Ratio
KS58A20N	DP	10	V _{DD} : 33.3/66.6
			V _{SS} : 40/60
KS58B20N	DP	20	V _{DD} : 33.3/66.6
			V _{SS} : 40/60
KS58C20N	DP̄	10	V _{DD} : 33.3/16.6
			V _{SS} : 40/60
KS58D20N	DP̄	20	V _{DD} : 33.3/66.6
			V _{SS} : 40/60

PIN CONFIGURATION

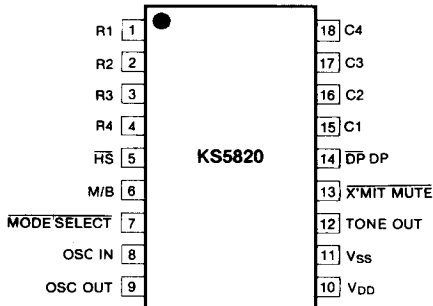

ARRANGEMENT OF KEYBOARD

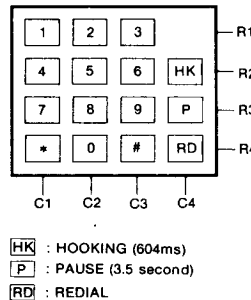

BLOCK DIAGRAM

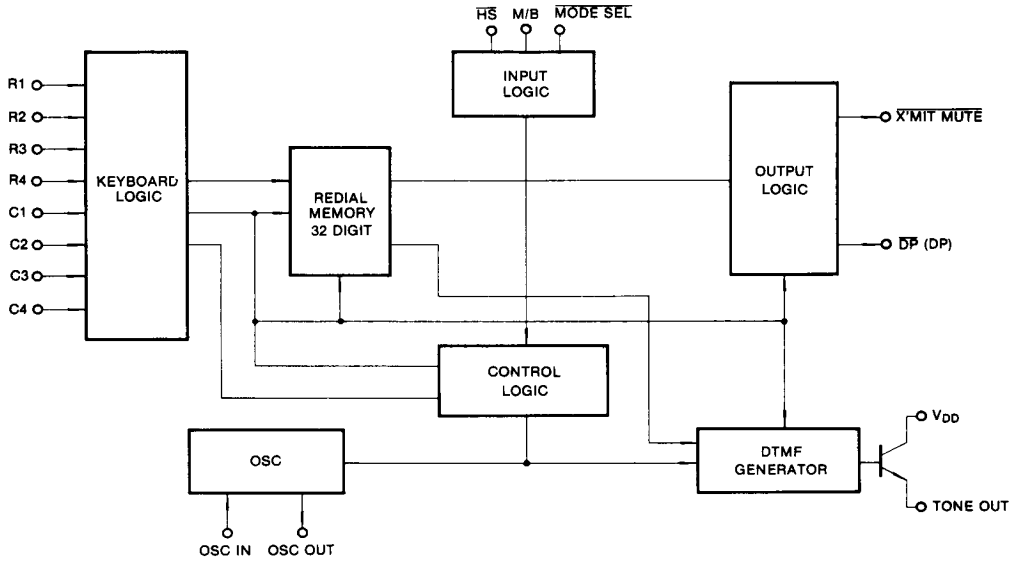

3

TONE DURATION & PAUSE IN REDIAL

Characteristic	Symbol	Typ	Unit
Tone Duration	T_D	110	mS
Minimum Pause	ITP	110	mS
Cycle Time	T_C	220	mS

TONE FREQUENCIES

Input	Specified	Actual	% Error
R1	697	699.1	+ 0.31
R2	770	766.2	- 0.49
R3	852	847.4	- 0.54
R4	941	948.0	+ 0.74
C1	1209	1215.7	+ 0.57
C2	1336	1331.7	- 0.32
C3	1477	1471.9	- 0.35

ABSOLUTE MAXIMUM RATINGS (Ta = 25°C)

Characteristics	Symbol	Value	Unit
Supply Voltage	V _{DD}	6.0	V
Input Voltage	V _{IN}	V _{SS} - 0.3, V _{DD} + 0.3	V
Output Voltage	V _{OUT}	V _{SS} - 0.3, V _{DD} + 0.3	
Output Voltage	V _{OUT}	≤ V _{DD} (\overline{DP} , X'MITMUTE)	V
Tone Output Current	I _{TONE}	50	mA
Power Dissipation	P _D	500	mW
Operating Temperature	T _{opr}	- 20 ~ + 70	°C
Storage Temperature	T _{stg}	- 40 ~ + 125	

ELECTRICAL CHARACTERISTICS(V_{SS} = 0V, V_{DD} = 3.5V, fx'tal = 3.579545MHz, Ta = 25°C, unless otherwise noted)

Characteristic	Symbol	Test Conditions		Min	Typ	Max	Unit
Operating Voltage Range	V _{DDP}	Pulse Mode	All inputs connected to V _{DD} or V _{SS}	2.0		5.5	V
	V _{DDT}	Tone Mode		2.0		5.5	
Memory Retention Voltage	V _{DR}			1.0			
Operating Supply Current	I _{DDP}	MODE = V _{DD}	One key selected HS = V _{SS} . All outputs unloaded		0.3	0.5	mA
	I _{DDT}	MODE = V _{SS}			0.5	1.0	
Standby Current	I _{SD1}	HS = V _{DD} = 1.5V	No key selected. All outputs unloaded			0.05	μA
	I _{SD2}	HS = V _{SS}				50	
Output Current	I _{OD1}	\overline{DP}	V _{OL} = 0.4V	V _{DD} = 3.5V	1.7	5.0	mA
	I _{OD2}	X'MIT MUTE		V _{DD} = 2.5V	0.5	1.5	
Input Voltage	V _{IH}	R1-R4, C1-C3, HS, M/B		0.8V _{DD}		V _{DD}	V
	V _{IL}	MODE SELECT		V _{SS}		0.2V _{DD}	
Input Current	I _{IN1}	V _{DD} = 3.5V V _{IN} = 0V	R1-R4			116	μA
	I _{IN2}	V _{DD} = 2.5V V _{IN} = 0V				50	
Valid Key Entry Time	T _{kd}			23		25.3	mS
Column and Row Scanning Frequency	F _{cr}				437		Hz
Auto Access Pause Time	T _{ap}				3.5		sec
Tone Output	V _{or}	ROW TONE ONLY	V _{DD} = 2.5V R _L = 5K	- 16.0		- 12.0	dBV
			V _{DD} = 3.5V R _L = 5K	- 14.0		- 11.0	
Ratio of Column to Row Tone	dB _{cr}	V _{DD} = 3.5V		1.0	2.0	3.0	dB
Distortion	%DIS	V _{DD} = 3.5V				7	%
Tone Output Delay Time	T _{psd}				1.5		mS

PIN DESCRIPTION

3

Pin	Name	Description									
1-4 15-18	R1-R4 C1-C4	Keyboard (R1, R2, R3, R4, C1, C2, C3, C4) These inputs can be interfaced to an XY matrix keyboard. C1-C4 & R1-R4 are set to low at On Hook (\overline{HS} = high). C1-C4 key inputs are set to low and R1-R4 are set to high at OFF HOOK (\overline{HS} = low) which enables the key-input operation. The oscillator starts running when a keypress is detected. Scanning signals are presented at both column and row inputs (TYP: 437Hz) until the input key is released. Key inputs are compatible with standard 2-of-8 form or single-contact keyboard. Debouncing is provided to avoid false entry (TYP: 25mS).									
5	\overline{HS}	Hook Switch This input detects the state of the hook switch contact. "Off Hook" corresponds to V_{SS} condition. "On Hook" corresponds to V_{DD} condition.									
6	M/B	Make/Break Ratio This input provides the selection of the Make/Break ratio (33.3: 66.6/40:60) when M/B is connected to V_{DD}/V_{SS} .									
7	MODE SELECT	Mode Select Input Pulse/DTMF mode is selected as shown in the following table. Initial Mode means the state after going Off Hook ($\overline{HS} \rightarrow "V_{SS}"$) <table border="1" style="margin: 10px auto;"> <thead> <tr> <th>MODE SELECT</th> <th>INITIAL MODE</th> <th>SWITCHING ENTRY MODE</th> </tr> </thead> <tbody> <tr> <td>V_{DD}</td> <td>Pulse</td> <td>MODE SELECT Input = V_{SS}</td> </tr> <tr> <td>V_{SS}</td> <td>Tone</td> <td>N/A</td> </tr> </tbody> </table>	MODE SELECT	INITIAL MODE	SWITCHING ENTRY MODE	V_{DD}	Pulse	MODE SELECT Input = V_{SS}	V_{SS}	Tone	N/A
MODE SELECT	INITIAL MODE	SWITCHING ENTRY MODE									
V_{DD}	Pulse	MODE SELECT Input = V_{SS}									
V_{SS}	Tone	N/A									
8-9	OSC IN OSC OUT	Oscillator Input/Output These pins are provided to connect an external 3.58MHz crystal. Oscillator starts (at Off Hook) and is sustained until pulse or DTMF signals are finished.									
10-11	V_{DD} , V_{SS}	Power These are the power supply inputs. The device is designed to be operated on 2.0V to 5.5V.									
12	TONE OUT	DTMF Signal Output When a valid keypress is detected in DTMF mode appropriate low and high group frequencies are generated which hybrid the Dual Tone Output. Tone out is Off State in pulse mode.									
13	X'MIT MUTE	X'mit Mute Output <table border="1" style="margin: 10px auto;"> <tr> <td>HS</td> <td>X'mit Mute Output</td> </tr> <tr> <td>V_{DD}</td> <td>"ON"</td> </tr> <tr> <td>V_{SS}</td> <td>Normally "OFF" "ON" during pulse and DTMF dialing</td> </tr> </table> (N channel open drain)	HS	X'mit Mute Output	V_{DD}	"ON"	V_{SS}	Normally "OFF" "ON" during pulse and DTMF dialing			
HS	X'mit Mute Output										
V_{DD}	"ON"										
V_{SS}	Normally "OFF" "ON" during pulse and DTMF dialing										
14	DP, DP	Dial Pulse Out DP: The normal output will be "OFF" during break and "ON" during make at "OFF HOOK." The output will be "ON" at "ON HOOK," DP: The normal output will be "ON" during break and "OFF" during make at "OFF HOOK." The output will be "OFF" at "ON HOOK."									



KEYBOARD OPERATION

1. SINGLE MODE OPERATION

• Pulse Mode Operation

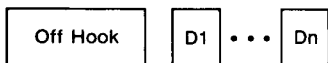

Pulse mode is defined by the initial mode after going Off Hook and latched at $\overline{D1}$ key entry. This is the condition under $\text{Mode Select} = V_{DD}$.

• Tone Mode Operation



Tone mode is defined by the initial mode after going Off Hook and latched at $\overline{D1}$ key entry. This condition is under $\text{Mode Select} = V_{SS}$.

• Manual Dialing with Automatic Access Pause



Multiple Pause key entries can be accepted and stored in the redial memory, each as a digit. Each \overline{P} key provides 3.5 seconds pause time, but the \overline{P} key entry as the first digit after going Off Hook is ignored. The $\overline{*}$ key can also be used as a pause key in the pulse mode. Pause (s) can be cancelled with the \overline{P} or \overline{RD} key during pause time in redialing.

\overline{D} = Any numeric key.

• Redialing

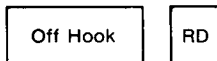

Up to 32 digits can be dialed with the \overline{RD} key. The \overline{RD} key is disabled while pulse or DTMF signals are transmitted. When more than 32 digits are stored, redial is also inhibited. The $\overline{\#}$ key can be used as the \overline{RD} key in the pulse mode.

• Inhibiting Redial

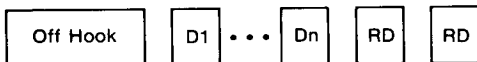

Redial can be inhibited by depressing the \overline{RD} key twice after DTMF or pulse signals are transmitted.

2. PULSE/TONE SWITCHABLE OPERATION

- Mode Switching by **MODE SELECT** Input

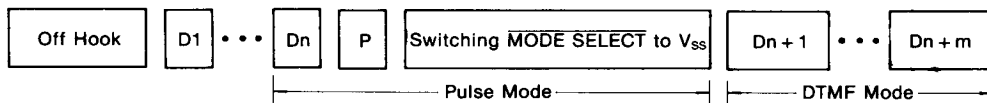

The pulse mode is initially defined $\overline{\text{MODE SELECT}} = V_{DD}$. Mode switching to the DTMF mode can be accepted by $\overline{\text{MODE SELECT}} = V_{SS}$, the DTMF mode will be set up after the pulse mode is finished. In this mode, digits $\overline{D_{n+1}}$... $\overline{D_{n+m}}$ are transmitted from Tone Out as DTMF signals by depressing the corresponding keys.

If no \overline{P} key is contained serially before or after mode switching, the following condition is obtained.

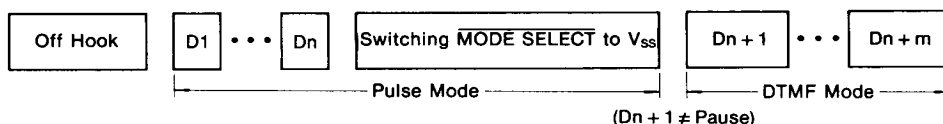

If digit $\overline{D_{n+1}}$ is depressed after the pulse mode is finished, the DTMF mode will be set up after the last pulse signal ($\overline{D_n}$) is generated. In this mode, digits $\overline{D_{n+1}}$... $\overline{D_{n+m}}$ are transmitted from Tone Out as DTMF signals by depressing the corresponding keys. If digit $\overline{D_{n+1}}$ is depressed during dialing pulse signals, DTMF mode, in the Hold State, will be set after the last pulse signal $\overline{D_n}$ is finished. MODE OUT will flash to indicate this Hold State $\overline{D_{n+1}}$... $\overline{D_{n+m}}$ is stored in the radial memory as DTMF data and not transmitted from Tone Out. When it is ready to transmit the DTMF data in radial memory, the \overline{T} , \overline{RD} or \overline{P} key is depressed to reset this Hold State and $\overline{D_{n+1}}$... $\overline{D_{n+m}}$ data are serially transmitted.

Single Tone Operation in DTMF Mode (Test mode)

1. The M/B pin is used to trigger the chip into the test mode by applying a positive or negative pulse after "Off Hook." The test mode is sustained until On Hook. The single tone is shown in the following table which contrast with the normal mode.

Normal mode

R1	1	2	3
R2	4	5	6
R3	7	8	9
R4	*	0	#
	C1	C2	C3

Single tone mode

R1	R1	C2	C3
R2	C1	C2	R2
R3	R3	C2	C3
R4	C1	R4	C3
	C1	C2	C3

2. The single tone can be generated by simultaneously depressing two digit keys in the appropriate Row and Column. If the two digit keys are not in the same Row or Column, the dual tone is disabled and no output is provided.



TONE MODE TIMING ($\overline{\text{MODE SELECT}} = V_{SS}$)

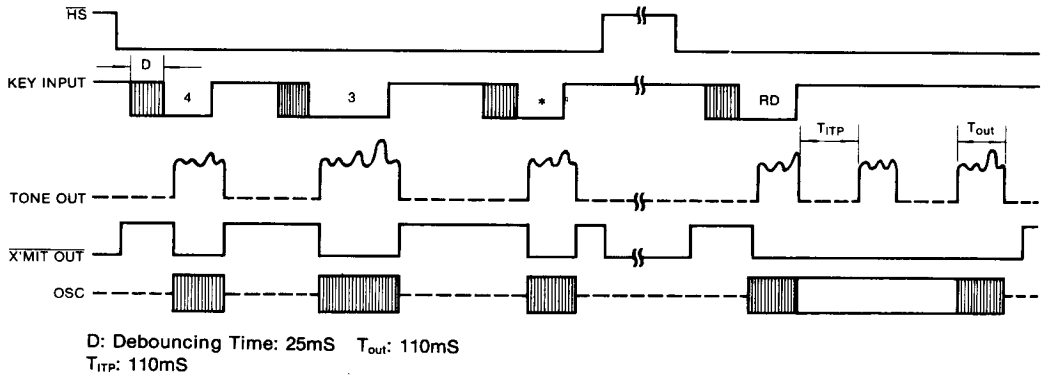

PULSE MODE TIMING ($\overline{\text{MODE SELECT}} = V_{DD}$)

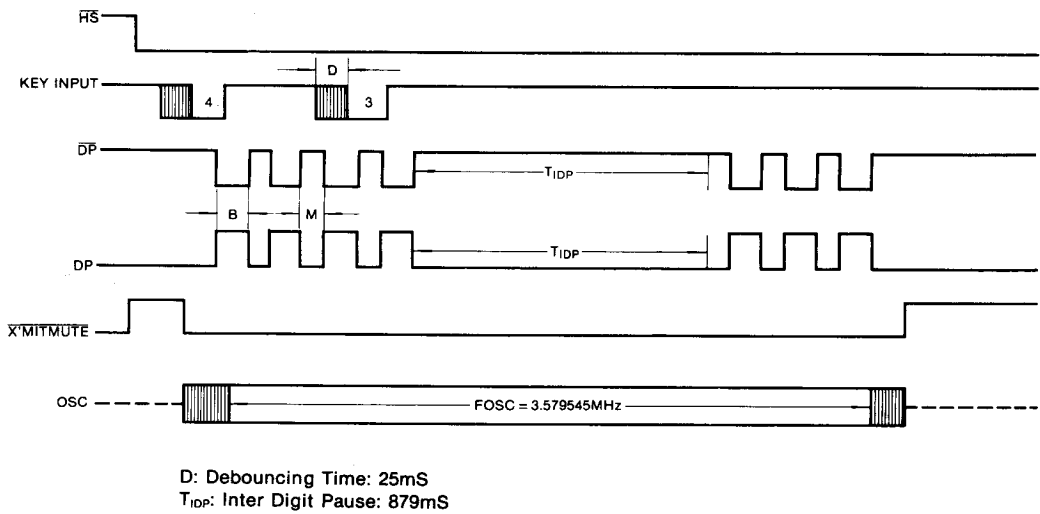

TIMING DIAGRAM (for Switching Mode Operation by $\overline{\text{MODE SELECT}}$ Input)

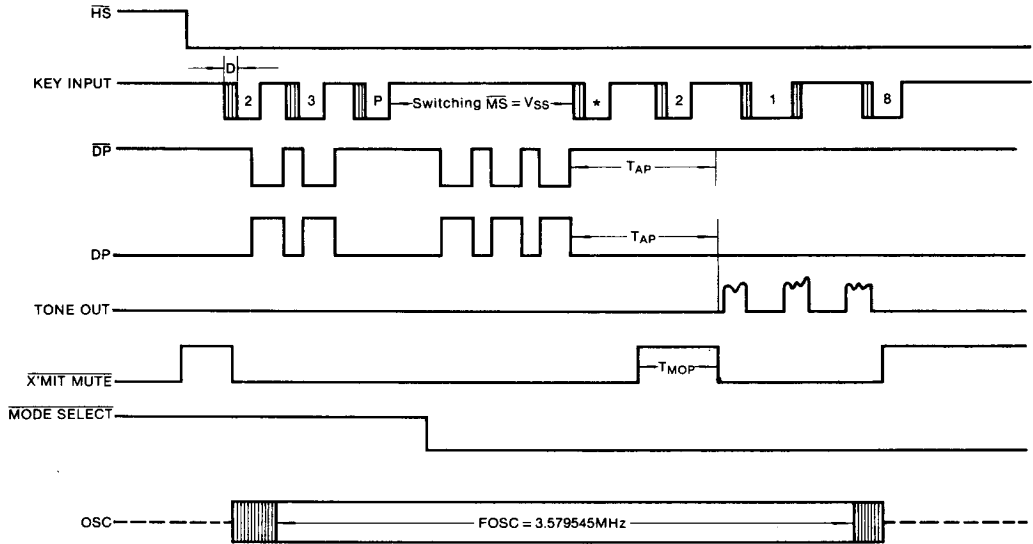

T_{AP} : Auto Pause Time 3.5sec

3