

High Voltage IGBT

IXSH 45N120B
IXST 45N120B

"S" Series - Improved SCSOA Capability

$$I_{C25} = 75 \text{ A}$$

$$V_{CES} = 1200 \text{ V}$$

$$V_{CE(sat)} = 3.0 \text{ V}$$

Preliminary data

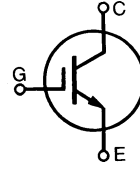

Symbol	Test Conditions	Maximum Ratings	
V_{CES}	$T_J = 25^\circ\text{C}$ to 150°C	1200	V
V_{CGR}	$T_J = 25^\circ\text{C}$ to 150°C ; $R_{GE} = 1 \text{ M}\Omega$	1200	V
V_{GES}	Continuous	± 20	V
V_{GEM}	Transient	± 30	V
I_{C25}	$T_C = 25^\circ\text{C}$ (limited by leads)	75	A
I_{C90}	$T_C = 90^\circ\text{C}$	45	A
I_{CM}	$T_C = 25^\circ\text{C}$, 1 ms	180	A
SSOA (RBSOA)	$V_{GE} = 15 \text{ V}$, $T_J = 125^\circ\text{C}$, $R_G = 5 \Omega$ Clamped inductive load	$I_{CM} = 90$ @ $0.8 V_{CES}$	A
t_{SC}	$T_J = 125^\circ\text{C}$, $V_{GE} = 720 \text{ V}$; $V_{GE} = 15 \text{ V}$, $R_G = 5 \Omega$	10	μs
P_C	$T_C = 25^\circ\text{C}$	300	W
T_J		-55 ... +150	$^\circ\text{C}$
T_{JM}		150	$^\circ\text{C}$
T_{stg}		-55 ... +150	$^\circ\text{C}$
M_d	Mounting torque (TO-247)	1.13/10	Nm/lb.in.
Maximum lead temperature for soldering 1.6 mm (0.062 in.) from case for 10 s		300	$^\circ\text{C}$
Weight	TO-247	6	g

TO-247 AD (IXSH)

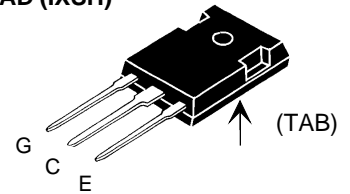

TO-268 (IXST)

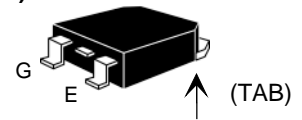

G = Gate
S = Emitter

C = Collector
TAB = Collector

Features

- Epitaxial Silicon drift region
 - fast switching
 - small tail current
- MOS gate turn-on for drive simplicity

Applications

- AC motor speed control
- DC servo and robot drives
- Uninterruptible power supplies (UPS)
- Switched-mode and resonant-mode power supplies
- Welding

Symbol	Test Conditions	Characteristic Values ($T_J = 25^\circ\text{C}$, unless otherwise specified)		
		min.	typ.	max.
BV_{CES}	$I_C = 1.0 \text{ mA}$, $V_{GE} = 0 \text{ V}$	1200		V
$V_{GE(th)}$	$I_C = 250 \mu\text{A}$, $V_{CE} = V_{GE}$	3		6 V
I_{CES}	$V_{CE} = 0.8 \cdot V_{CES}$ Note 1 $T_J = 125^\circ\text{C}$			50 μA 2.5 mA
I_{GES}	$V_{CE} = 0 \text{ V}$, $V_{GE} = \pm 20 \text{ V}$			$\pm 100 \text{ nA}$
$V_{CE(sat)}$	$I_C = I_{C90}$, $V_{GE} = 15 \text{ V}$ Note 2 $T_J = 125^\circ\text{C}$	2.5	3.0	V
		2.6		V

Symbol	Test Conditions	Characteristic Values ($T_J = 25^\circ\text{C}$, unless otherwise specified)		
		min.	typ.	max.
g_{fs}	$I_C = I_{C90}, V_{CE} = 10\text{ V}$, Note 2	16	23	S
C_{ies}	$V_{CE} = 25\text{ V}, V_{GE} = 0\text{ V}, f = 1\text{ MHz}$		3300	pF
C_{oes}			240	pF
C_{res}			65	pF
Q_g	$I_C = I_{C90}, V_{GE} = 15\text{ V}, V_{CE} = 0.5 V_{CES}$		120	nC
Q_{ge}			40	nC
Q_{gc}			45	nC
$t_{d(on)}$	Inductive load, $T_J = 25^\circ\text{C}$		36	ns
t_{ri}	$I_C = I_{C90}, V_{GE} = 15\text{ V}$		27	ns
$t_{d(off)}$	$R_G = 5\ \Omega$ $V_{CE} = 0.8 V_{CES}$ Note 3		360	500 ns
t_{fi}			380	750 ns
E_{off}			13	22 mJ
$t_{d(on)}$	Inductive load, $T_J = 125^\circ\text{C}$		38	ns
t_{ri}	$I_C = I_{C90}, V_{GE} = 15\text{ V}$		29	ns
E_{on}	$R_G = 5\ \Omega, V_{CE} = 0.8 V_{CES}$ Note 3		2.9	mJ
$t_{d(off)}$			440	ns
t_{fi}			700	ns
E_{off}			22	mJ
R_{thJC}				0.42 K/W
R_{thCK}	(TO-247)		0.25	K/W

- Notes: 1. Device must be heatsunk for high temperature leakage current measurements to avoid thermal runaway.
 2. Pulse test, $t \leq 300\ \mu\text{s}$, duty cycle $\leq 2\%$
 3. Switching times may increase for V_{CE} (Clamp) $> 0.8 \cdot V_{CES}$, higher T_J or increased R_G .

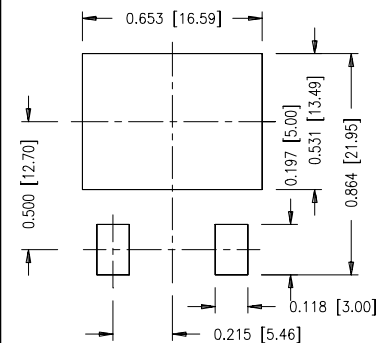
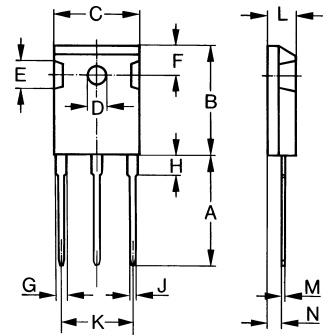
Min. Recommended Footprint

TO-247 AD (IXSH) Outline

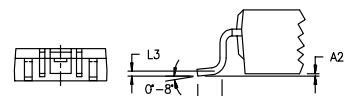
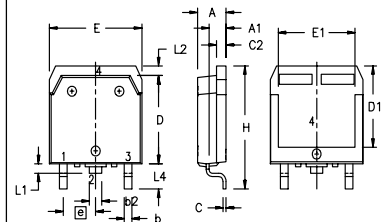
Dim.	Millimeter		Inches	
	Min.	Max.	Min.	Max.
A	19.81	20.32	0.780	0.800
B	20.80	21.46	0.819	0.845
C	15.75	16.26	0.610	0.640
D	3.55	3.65	0.140	0.144
E	4.32	5.49	0.170	0.216
F	5.4	6.2	0.212	0.244
G	1.65	2.13	0.065	0.084
H	-	4.5	-	0.177
J	1.0	1.4	0.040	0.055
K	10.8	11.0	0.426	0.433
L	4.7	5.3	0.185	0.209
M	0.4	0.8	0.016	0.031
N	1.5	2.49	0.087	0.102

TO-268AA (D³ PAK)

Dim.	Millimeter		Inches	
	Min.	Max.	Min.	Max.
A	4.9	5.1	.193	.201
A ₁	2.7	2.9	.106	.114
A ₂	.02	.25	.001	.010
b	1.15	1.45	.045	.057
b ₂	1.9	2.1	.75	.83
C	.4	.65	.016	.026
D	13.80	14.00	.543	.551
E	15.85	16.05	.624	.632
E ₁	13.3	13.6	.524	.535
e	5.45 BSC		.215 BSC	
H	18.70	19.10	.736	.752
L	2.40	2.70	.094	.106
L ₁	1.20	1.40	.047	.055
L ₂	1.00	1.15	.039	.045
L ₃	0.25 BSC		.010 BSC	
L ₄	3.80	4.10	.150	.161