



Magnetic Transducer EMX-11T05P

Rev.2**FEATURES:**

- Low Frequency
- Small Size and Compact
- Rich Sound

APPLICATIONS:

- Automatic Control Equipment
- Communication Equipment
- Electronic Instruments

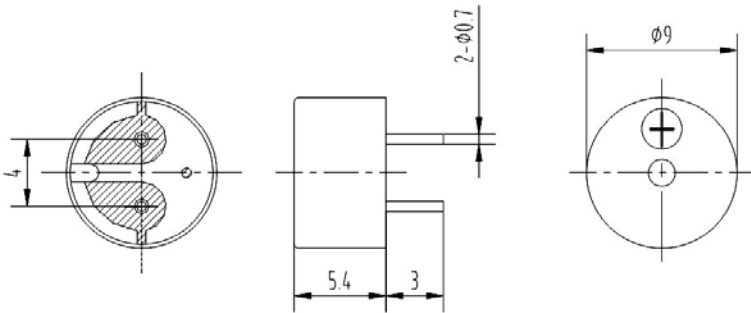
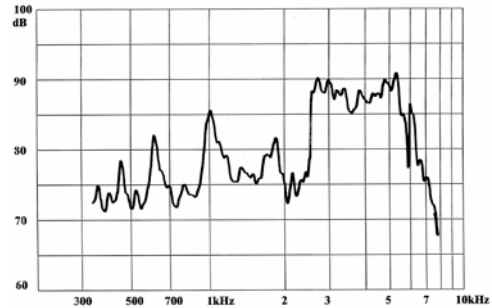
DIMENSIONS: (Unit: mm)**CHARACTERISTICS:****ELECTRICAL SPECIFICATIONS:**

Min. Sound Pressure Level at
 5V Square Wave /10cm/2731Hz.....85dB(A)
 Rated Voltage.....5V
 Operating Voltage.....4.5~5.5V
 Max Consumption at
 2731Hz/10Vp-p Square Wave.....75mA/5V_{DC}
 Resonant Frequency2731Hz
 Coil Resistance.....25±4Ω
 Operating Temperature-20~+70°C
 Storage Temperature-30~+80°C
 Weight1.0g

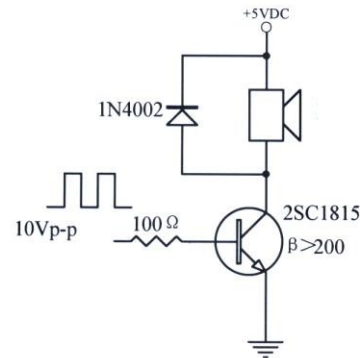
TEST CIRCUIT:**PACKING INFORMATION:**

Packing: 3000pcs per export carton
 Carton Size: 47x25x27 cm
 G. Weight: 4.5 kgs N. Weight: 3.0 kgs
 Address: No. 88 Jinhui East Road Yinzhou, Ningbo, 315040 P. R. China
 Sales Tel: +86-574-87809820(International)/87805605(Domestic)
 Fax: +86-574-87803761