

1 Introduction

1.1 Features

- Four Separate Video Decoder Channels With Features for Each Channel:
 - Accept NTSC (M, 4.43), PAL (B, D, G, H, I, M, N), and SECAM (B, D, G, K, K1, L) Video Data
 - Support ITU-R BT.601 Standard Sampling
 - High-Speed 9-Bit Analog-to-Digital Converter (ADC)
 - Two Composite Inputs or One S-video Input (for Each Channel)
 - Fully Differential CMOS Analog Preprocessing Channels With Clamping and Automatic Gain Control (AGC) for Best Signal to Noise (SNR) Performance
 - Brightness, Contrast, Saturation, Hue, and Sharpness Control Through Inter-Integrated Circuit (I²C)
 - Complementary 4-Line (3-H Delay) Adaptive Comb Filters for Both Cross-Luminance and Cross-Chrominance Noise Reduction
 - Patented Architecture for Locking to Weak, Noisy, or Unstable Signals
- Four Independent Polymorphic Scalers
- Single or Concurrent Scaled and Unscaled Outputs Via Dual Clocking Data, Interleaved 54-MHz Data or Single 27-MHz Clock
- Scaled/Unscaled Image Toggle Mode Gives Variable Field Rate for Both Scaled and Unscaled Video
- Low Power Consumption: 700 mW Typical
- 128-Pin Thin Quad Flat Pack (TQFP) Package
- Single 14.31818-MHz Crystal for All Standards and All Channels
- Internal Phase-Locked Loop (PLL) for Line-Locked Clock (Separate for Each Channel) and Sampling
- Sub-Carrier Genlock Output for Synchronizing Color Sub-Carrier of External Encoder
- Standard Programmable Video Output Format
 - ITU-R BT.656, 8-Bit 4:2:2 With Embedded Syncs
 - 8-Bit 4:2:2 With Discrete Syncs
- Advanced Programmable Video Output Formats
 - 2× Over-Sampled Raw Vertical Blanking Interval (VBI) Data During Active Video
 - Sliced VBI Data During Horizontal Blanking or Active Video
- VBI Modes Supported:
 - Teletext (NABTS, WST)
 - Closed-Caption Decode With FIFO, and Extended Data Services (EDS)
 - Wide Screen Signaling (WSS), Video Program System (VPS), Copy Generation Management System (CGMS), Vertical Interval Time Code (VITC)
 - Gemstar 1×/2× Electronic Program Guide Compatible Mode
 - Custom Configuration Mode Allows User to Program the Slice Engine for Unique VBI Data Signals
- Improved Fast Lock Mode Can Be Used When Input Video Standard Is Known and Signals on Switching Channels Are Clean
- Four Possible I²C Addresses Allowing 16 Decoder Channels on a Single I²C Bus

1.2 Applications

- The following is a partial list of suggested applications:
 - Security Camera Systems
 - Large Format Video Wall Displays
 - Games Systems



Please be aware that an important notice concerning availability, standard warranty, and use in critical applications of Texas Instruments semiconductor products and disclaimers thereto appears at the end of this document.

PowerPAD is a trademark of Texas Instruments.

1.3 Description

The TVP5154 device is a 4-channel, low-power, NTSC/PAL/SECAM video decoder. Available in a space-saving 128-pin thin quad flat pack (TQFP) package, each channel of the TVP5154 decoder converts NTSC, PAL, or SECAM video signals to 8-bit ITU-R BT.656 format. Discrete syncs are also available. All four channels of the TVP5154 are independently controllable. The decoders share one crystal for all channels and for all supported standards. The TVP5154 can be programmed using a single inter-integrated circuit (I²C) serial interface. The decoder uses a 1.8-V supply for its analog and digital supplies, and a 3.3-V supply for its I/O. The optimized architecture of the TVP5154 decoder allows for low power consumption. The decoder consumes less than 720 mW of power in typical operation.

Each channel of the TVP5154 is an independent video decoder with a programmable polymorphic scaler. Each channel converts baseband analog video into digital YCbCr 4:2:2 component video, which can then be scaled down to any resolution to 1/256 vertical and 15-bit horizontal in 2-pixel decrements. Composite and S-video inputs are supported. Each channel includes one 9-bit analog-to-digital converter (ADC) with 2× sampling. Sampling is ITU-R BT.601 (27.0) MHz, generated from a single 14.31818-MHz crystal or oscillator input) and is line locked. The output formats can be 8-bit 4:2:2 with discrete syncs or 8-bit ITU-R BT.656 with embedded synchronization.

The TVP5154 utilizes Texas Instruments patented technology for locking to weak, noisy, or unstable signals. A real-time control (RTC) output is generated for each channel for synchronizing downstream video encoders.

Complementary 4-line adaptive comb filtering is available per channel for both the luma and chroma data paths to reduce both cross-luma and cross-chroma artifacts. A chroma trap filter also is available.

An improved fast lock mode can be used when the input video standard is known and the signals on the switching channels are clean. Note, switching from snow and/or noisy channels to good channels takes longer. In fast lock mode, video lock is achieved in three fields or less.

Video characteristics, including hue, contrast, brightness, saturation, and sharpness, may be independently programmed for each channel using the industry standard I²C serial interface. The TVP5154 generates synchronization, blanking, lock, and clock signals in addition to digital video outputs for each channel. The TVP5154 includes methods for advanced vertical blanking interval (VBI) data retrieval. The VBI data processor slices, parses, and performs error checking on teletext, closed caption, and other data in several formats.

I²C commands can be sent to one or more decoder cores simultaneously, reducing the amount of I²C activity necessary to configure each core. A register controls which decoder core receives I²C commands, and can be configured such that all four decoders receive commands at the same time.

The main blocks for each of the channels of the TVP5154 decoder include:

- Robust sync detector
- ADC with analog processor
- Y/C separation using 4-line adaptive comb filter
- Independent, concurrent scaler outputs
- Chrominance processor
- Luminance processor
- Video clock/timing processor and power-down control
- I²C interface
- VBI data processor

1.3.1 Related Products

- TVP5150
- TVP5150AM1
- TVP5145
- TVP5146
- TVP5147
- TVP5160

1.3.2 Ordering Information

T_A	PACKAGED DEVICES	PACKAGE OPTION
	128-PIN TQFP-PowerPAD™	
0°C to 70°C	TVP5154PNP	Tray
	TVP5154PNPR	Tape and reel

2 Functional Block Diagram

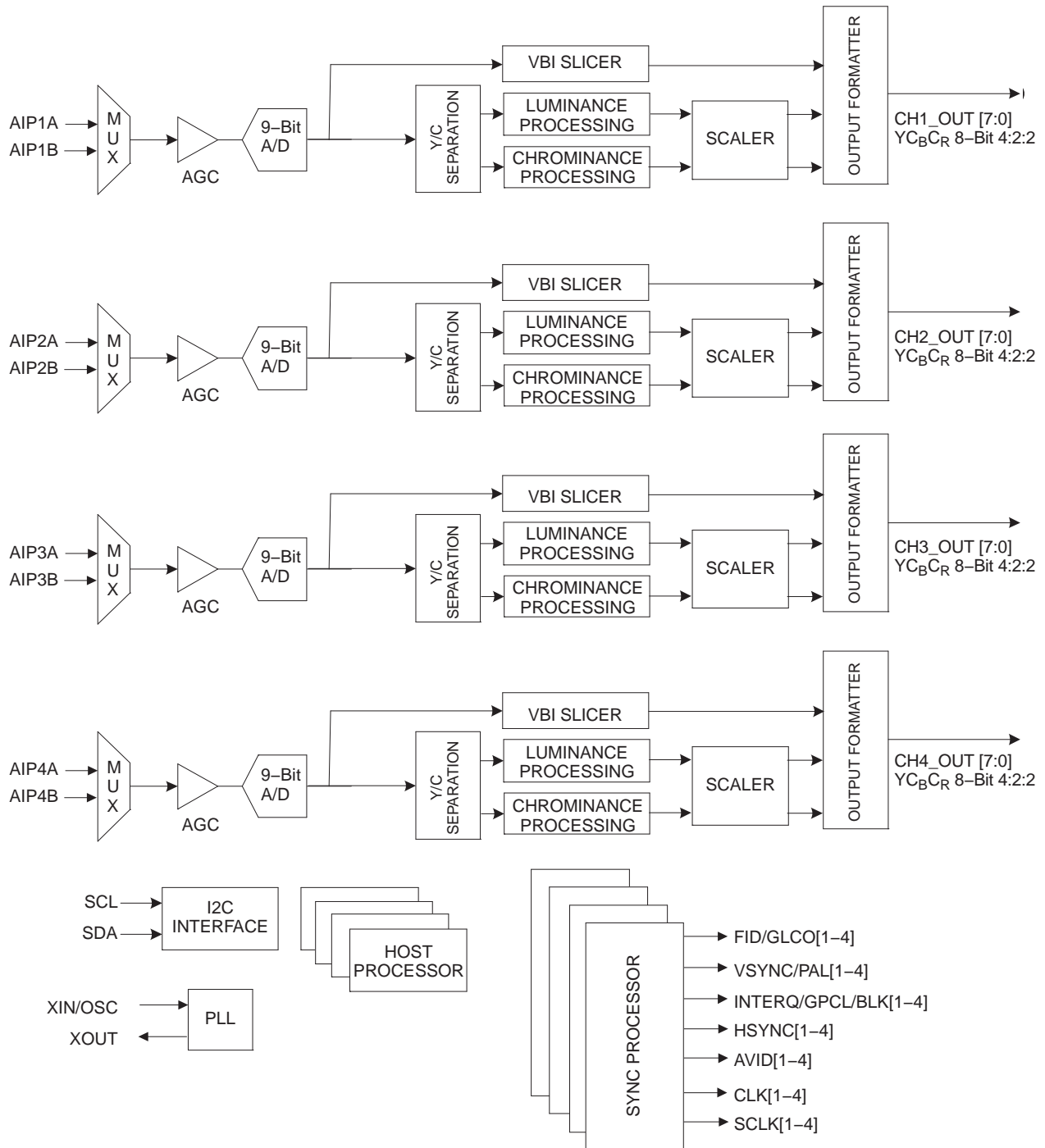
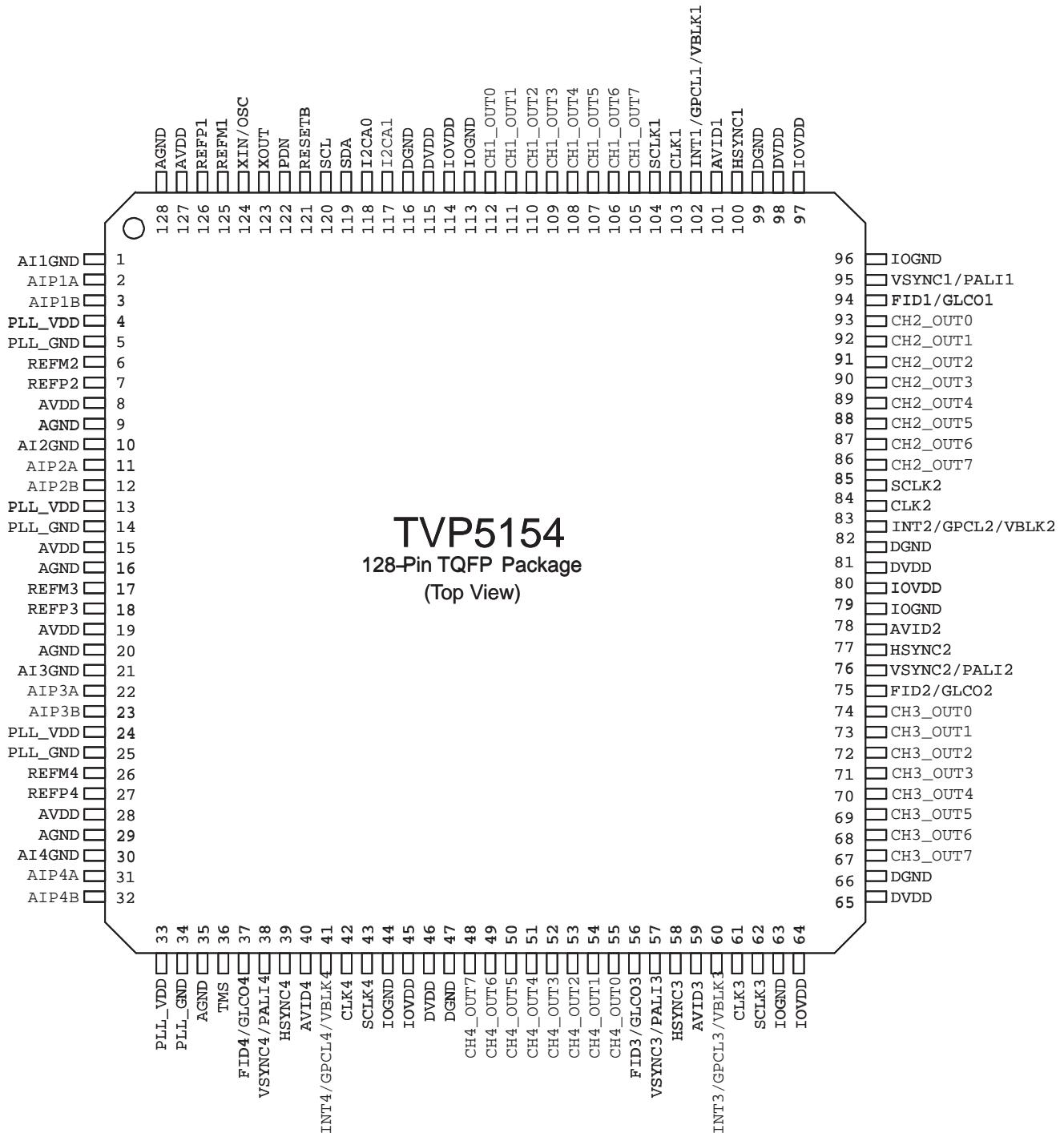

Figure 2-1. Functional Block Diagram

3 Terminal Assignments

3.1 Pinout



TVP5154

4-CHANNEL LOW-POWER PAL/NTSC/SECAM VIDEO DECODER WITH INDEPENDENT SCALERS AND FAST LOCK

SLES163A—MARCH 2006—REVISED JULY 2006

3.2 Terminal Functions

TERMINAL		I/O	DESCRIPTION
NAME	NO.		
Analog Section			
AIP1A AIP1B	2 3	I	Analog inputs for Channel 1. Connect to the video analog input via a 0.1- μ F capacitor. The maximum input range is 0–0.75 V_{PP} , and may require an attenuator to reduce the input amplitude to the desired level. If not used, connect to AGND via a 0.1- μ F capacitor. Refer to the schematic in Section 12.
AIP2A AIP2B	11 12	I	Analog inputs for Channel 2. Connect to the video analog input via a 0.1- μ F capacitor. The maximum input range is 0–0.75 V_{PP} , and may require an attenuator to reduce the input amplitude to the desired level. If not used, connect to AGND via a 0.1- μ F capacitor. Refer to the schematic in Section 12.
AIP3A AIP3B	22 23	I	Analog inputs for Channel 3. Connect to the video analog input via a 0.1- μ F capacitor. The maximum input range is 0–0.75 V_{PP} , and may require an attenuator to reduce the input amplitude to the desired level. If not used, connect to AGND via a 0.1- μ F capacitor. Refer to the schematic in Section 12.
AIP4A AIP4B	31 32	I	Analog inputs for Channel 4. Connect to the video analog input via a 0.1- μ F capacitor. The maximum input range is 0–0.75 V_{PP} , and may require an attenuator to reduce the input amplitude to the desired level. If not used, connect to AGND via a 0.1- μ F capacitor. Refer to the schematic in Section 12.
AVDD	8, 15, 19, 28, 127	P	Analog power supply. Connect to 1.8-V analog supply.
AGND	9, 16, 20, 29, 35, 128	P	Analog power supply return. Connect to analog ground.
AixGND	1, 10, 21, 30	P	Analog input signal return. Connect to analog ground.
PLL_GND	5, 14, 25, 34	P	PLL power supply return. Connect to analog ground.
PLL_VDD	4, 13, 24, 33	P	PLL power supply. Connect to 1.8-V analog supply.
REFMx	6, 17, 26, 125	I	Reference supply decoupling . Connect to analog ground through a 1- μ F capacitor. Connect to REFPx through a 1- μ F capacitor.
REFPx	7, 18, 27, 126	I	Reference supply decoupling . Connect to analog ground through a 1- μ F capacitor. Connect to REFMx through a 1- μ F capacitor.
Digital Section			
DGND	47, 66, 82, 99, 116	P	Digital power supply return. Connect to digital ground
DVDD	46, 65, 81, 98, 115	P	Digital power supply. Connect to 1.8-V digital supply.
IOGND	44, 63, 79, 96, 113	P	I/O power supply return. Connect to digital ground.
IOVDD	45, 64, 80, 97, 114	P	I/O power supply. Connect to 3.3-V digital supply
FID1/GLCO1 FID2/GLCO2 FID3/GLCO3 FID4/GLCO4	94 75 56 37	O	1. FID: Odd/even field indicator or vertical lock indicator. For the odd/even indicator, a 1 indicates the odd field. 2. GLCO: This serial output carries color PLL information. A slave device can decode the information to allow chroma frequency control from the TVP5154 decoder. Data is transmitted at the CLK rate in Genlock mode.
AVID1 AVID2 AVID3 AVID4	101 78 59 40	O	Active video indicator. This signal is high during the horizontal active time of the video output.
INTREQ1/GPCL1/VBLK1 INTREQ2/GPCL2/VBLK2 INTREQ3/GPCL3/VBLK3 INTREQ4/GPCL4/VBLK4	102 83 60 41	I/O	1. Interrupt request : Open drain when active low. 2. GPCL: General-purpose output. In this mode, the state of GPCL is directly programmed via I ² C. 3. VBLK: Vertical blank output. In this mode, the GPCL terminal is used to indicate the VBI of the output video. The beginning and end times of this signal are programmable via I ² C.

TERMINAL		I/O	DESCRIPTION
NAME	NO.		
HSYNC1 HSYNC2 HSYNC3 HSYNC4	100 77 58 39	O	Horizontal synchronization
VSYNC1 /PAL1 VSYNC2 /PAL2 VSYNC3 /PAL3 VSYNC4 /PAL4	95 76 57 38	O	1. VSYNC: Vertical synchronization 2. PAL: PAL line indicator or horizontal lock indicator. For the PAL line indicator, a 1 indicates a noninverted line, and a 0 indicates an inverted line.
PDN	122	I	Power down (active low). A 0 on this pin puts the decoder in standby mode. PDN preserves the value of the registers.
RESETB	121	I	Active-low reset. RESETB can be used only when PDN = 1. When RESETB is pulled low, it resets all the registers and restarts the internal microprocessor.
SCL	120	I/O	I ² C serial clock (open drain)
SDA	119	I/O	I ² C serial data (open drain)
I2CA0	118	I	During power-on reset, this pin is sampled along with pin 117 (I2CA1) to determine the I ² C address the device is configured to. A 10-k Ω resistor should pull this either high (to IOVDD) or low to select different I ² C device addresses.
I2CA1	117	I	During power-on reset, this pin is sampled along with pin 118 (I2CA0) to determine the I ² C address the device is configured to. A 10-k Ω resistor should pull this either high (to IOVDD) or low to select different I ² C device addresses.
CLK1 CLK2 CLK3 CLK4	103 84 61 42	O	Unscaled system data clock at either 27 MHz or 54 MHz
SCLK1 SCLK2 SCLK3 SCLK4	104 85 62 43	O	Scaled system data clock at 27 MHz. This signal can be used to qualify scaled/unscaled data when the unscaled system data clock is set to 54 MHz.
XIN/OSC XOUT	124 123	I O	External clock reference. The user may connect XIN to an oscillator or to one terminal of a crystal oscillator. The user may connect XOUT to the other terminal of the crystal oscillator or not connect XOUT at all. One single 14.31818-MHz crystal or oscillator is needed for ITU-R BT.601 sampling, for all supported standards.
CH1_OUT[7:0]	105–112	O	Decoded ITU-R BT.656 output/YCbCr 4:2:2 output with discrete sync for channel 1
CH2_OUT[7:0]	86–93	O	Decoded ITU-R BT.656 output/YCbCr 4:2:2 output with discrete sync for channel 2
CH3_OUT[7:0]	67–74	O	Decoded ITU-R BT.656 output/YCbCr 4:2:2 output with discrete sync for channel 3
CH4_OUT[7:0]	48–55	O	Decoded ITU-R BT.656 output/YCbCr 4:2:2 output with discrete sync for channel 4
TMS	36	I	Test-mode select. This pin should be connected to digital ground for correct device operation.

4 Functional Description

4.1 Analog Front End

Each channel of the TVP5154 decoder has an analog input channel that accepts two video inputs, which should be ac coupled through 0.1- μ F capacitors. The decoder supports a maximum input voltage range of 0.75 V; therefore, an attenuation of one-half is needed for standard input signals with a peak-to-peak variation of 1.5 V. The maximum parallel termination before the input to the device is 75 Ω . Refer to schematic at the end of this document for recommended configuration. The two analog input ports can be connected as follows:

- Two selectable composite video inputs or
- One S-video input

An internal clamping circuit restores the ac-coupled video signal to a fixed dc level.

The programmable gain amplifier (PGA) and the automatic gain control (AGC) circuit work together to ensure that the input signal is amplified or attenuated correctly, ensuring the proper input range for the ADC.

When switching CVBS inputs from one input to the other, the AGC settings are internally stored and the previous settings for the new input are restored. This eliminates flashes and dark frames associated with switching between inputs that have different signal amplitudes.

The ADC has nine bits of resolution and runs at a maximum speed of 27 MHz. The clock input for the ADC comes from the PLL.

4.2 Composite Processing Block Diagram

The composite processing block processes NTSC/PAL/SECAM signals into the YCbCr color space. [Figure 2-1](#) shows the basic architecture of this processing block.

[Figure 2-1](#) shows the luminance/chrominance (Y/C) separation process in the TVP5154 decoders. The composite video is multiplied by sub-carrier signals in the quadrature modulator to generate the color difference signals Cb and Cr. Cb and Cr are then low pass (LP) filtered to achieve the desired bandwidth and to reduce crosstalk.

An adaptive 4-line comb filter separates CbCr from Y. Chroma is remodulated through another quadrature modulator and subtracted from the line-delayed composite video to generate luma. Contrast, brightness, hue, saturation, and sharpness (using the peaking filter) are programmable via I²C.

The Y/C separation is bypassed for S-video input. For S-video, the remodulation path is disabled.

4.3 Adaptive Comb Filtering

The 4-line comb filter can be selectively bypassed in the luma or chroma path. If the comb filter is bypassed in the luma path, chroma notch filters are used. TI's patented adaptive 4-line comb filter algorithm reduces artifacts, such as hanging dots at color boundaries, and detects and properly handles false colors in high-frequency luminance images, such as a multiburst pattern or circle pattern.

4.4 Color Low-Pass Filter

In some applications, it is desirable to limit the Cb/Cr bandwidth to avoid crosstalk. This is especially true in the case of video signals that have asymmetrical Cb/Cr sidebands. The color LP filters provided limit the bandwidth of the Cb/Cr signals.

Color LP filters are needed when the comb filtering turns off, due to extreme color transitions in the input image. Refer to *Chrominance Control #2 Register*, for the response of these filters. The filters have three options that allow three different frequency responses based on the color frequency characteristics of the input video.

4.5 Luminance Processing

The luma component is derived from the composite signal by subtracting the remodulated chroma information. A line delay exists in this path to compensate for the line delay in the adaptive comb filter in the color processing chain. The luma information is then fed into the peaking circuit, which enhances the high-frequency components of the signal, thus, improving sharpness.

4.6 Chrominance Processing

For NTSC/PAL formats, the color processing begins with a quadrature demodulator. The Cb/Cr signals then pass through the gain control stage for chroma saturation adjustment. An adaptive comb filter is applied to the demodulated signals to separate chrominance and eliminate cross-chrominance artifacts. An automatic color-killer circuit is also included in this block. The color killer suppresses the chroma processing when the color burst of the video signal is weak or not present. The SECAM standard is similar to PAL except for the modulation of color, which is FM instead of QAM.

4.7 Timing Processor

The timing processor is a combination of hardware and software running in the internal microprocessor that serves to control horizontal lock to the input sync pulse edge, AGC and offset adjustment in the analog front end, and vertical sync detection.

4.8 VBI Data Processor

The TVP5154 VBI data processor (VDP) slices various data services, such as teletext (WST, NABTS), closed caption (CC), wide screen signaling (WSS), etc. These services are acquired by programming the VDP to enable standards in the VBI. The results are stored in a FIFO and/or registers. The teletext results are stored in a FIFO only. [Table 4-1](#) lists a summary of the types of VBI data supported according to the video standard. It supports ITU-R BT. 601 sampling for each.

Table 4-1. Data Types Supported by the VDP

LINE MODE REGISTER (D0h–FCh) BITS [3:0]	NAME	DESCRIPTION
0000b	WST SECAM	Teletext, SECAM
0001b	WST PAL B	Teletext, PAL, System B
0010b	WST PAL C	Teletext, PAL, System C
0011b	WST, NTSC B	Teletext, NTSC, System B
0100b	NABTS, NTSC C	Teletext, NTSC, System C
0101b	NABTS, NTSC D	Teletext, NTSC, System D (Japan)
0110b	CC, PAL	Closed caption PAL
0111b	CC, NTSC	Closed caption NTSC
1000b	WSS, PAL	Wide-screen signal, PAL
1001b	WSS, NTSC	Wide-screen signal, NTSC
1010b	VITC, PAL	Vertical interval timecode, PAL
1011b	VITC, NTSC	Vertical interval timecode, NTSC
1100b	VPS, PAL	Video program system, PAL
1111b	Active Video	Active video/full field

At power up, the host interface is required to program the VDP-configuration RAM (VDP-CRAM) contents with the lookup table (see Section 9.2.63). This is done through port address C3h. Each read from or write to this address auto increments an internal counter to the next RAM location. To access the VDP-CRAM, the line mode registers (D0h–FCh) must be programmed with FFh to avoid a conflict with the internal microprocessor and the VDP in both writing and reading. Full field mode must also be disabled.

Available VBI lines are from line 6 to line 27 of both field 1 and field 2. Each line can be any VBI mode.

Output data is available either through the VBI-FIFO (B0h) or through dedicated registers at 90h–AFh, both of which are available through the I²C port.

4.9 VBI FIFO and Ancillary Data in Video Stream

Sliced VBI data can be output as ancillary data in the video stream in the ITU-R BT.656 mode. VBI data is output during the horizontal blanking period following the line from which the data was retrieved. [Table 4-2](#) shows the header format and sequence of the ancillary data inserted into the video stream. This format is also used to store any VBI data into the FIFO. The size of FIFO is 512 bytes. Therefore, the FIFO can store up to 11 lines of teletext data with the NTSC NABTS standard.

Table 4-2. Ancillary Data Format and Sequence

BYTE NO.	D7 (MSB)	D6	D5	D4	D3	D2	D1	D0 (LSB)	DESCRIPTION		
0	0	0	0	0	0	0	0	0	Ancillary data preamble		
1	1	1	1	1	1	1	1	1			
2	1	1	1	1	1	1	1	1			
3	NEP	EP	0	1	0	DID2	DID1	DID0	Data ID (DID)		
4	NEP	EP	F5	F4	F3	F2	F1	F0	Secondary data ID (SDID)		
5	NEP	EP	N5	N4	N3	N2	N1	N0	Number of 32 bit data (NN)		
6	Video line # [7:0]								Internal data ID0 (IDID0)		
7	0	0	0	Data error	Match #1	Match #2	Video line # [9:8]		Internal data ID1 (IDID1)		
8	1. Data								Data byte	1st word	
9	2. Data								Data byte		
10	3. Data								Data byte		
11	4. Data								Data byte		
•	•								•	Nth word	
•	•								•		
	— 1. Data								Data byte		
	m. Data								Data byte		
	NEP	EP	CS[5:0]						Check sum		
4(N+2)-1	0	0	0	0	0	0	0	0	Fill byte		

EP: Even parity for D0–D5

NEP: Negated even parity

DID: 91h: Sliced data of VBI lines of first field
53h: Sliced data of line 24 to end of first field
55h: Sliced data of VBI lines of second field
97h: Sliced data of line 24 to end of second field

SDID: This field holds the data format taken from the line mode register of the corresponding line.

NN: Number of Dwords beginning with byte 8 through 4(N+2). This value is the number of Dwords where each Dword is 4 bytes.

IDID0: Transaction video line number [7:0]

IDID1: Bit 0/1 = Transaction video line number [9:8]

Bit 2 = Match 2 flag

Bit 3 = Match 1 flag

Bit 4 = 1 if an error was detected in the EDC block. 0 if not.

CS: Sum of D0–D7 of DID through last data byte

Fill byte: Fill bytes make a multiple of four bytes from byte 0 to last fill byte. For teletext modes, byte 8 is the sync pattern byte. Byte 9 is 1. Data (the first data byte).

4.10 Raw Video Data Output

The TVP5154 decoder can output raw A/D video data at 2× sampling rate for external VBI slicing. This is transmitted as an ancillary data block during the active horizontal portion of the line and during vertical blanking.

4.11 Output Formatter

The output formatter is responsible for generating the output digital video stream. The YCbCr digital output can be programmed as 8-bit 4:2:2 or 8-bit ITU-R BT.656 parallel interface standard. Depending on which output mode is selected, the output for each channel can be unscaled data, scaled data, or both scaled and unscaled data interleaved in various ways.

Table 4-3. Summary of Line Frequencies, Data Rates, and Pixel Counts

STANDARDS	HORIZONTAL LINE RATE (kHz)	PIXELS PER LINE	ACTIVE PIXELS PER LINE	CLK FREQUENCY (MHz)
NTSC (M, 4.43), ITU-R BT.601	15.73426	858	720	27.00
PAL (B, D, G, H, I), ITU-R BT.601	15.625	864	720	27.00
PAL (M), ITU-R BT.601	15.73426	858	720	27.00
PAL (N), ITU-R BT.601	15.625	864	720	27.00
SECAM, ITU-R BT.601	15.625	864	720	27.00

4.12 Synchronization Signals

External (discrete) syncs are provided via the following signals:

- VSYNC (vertical sync)
- FID/VLK (field indicator or vertical lock indicator)
- GPCL/VBLK (general-purpose I/O or vertical blanking indicator)
- PALI/HLK (PAL switch indicator or horizontal lock indicator)
- HSYNC (horizontal sync)
- AVID (active video indicator)

VSYNC, FID, PALI, and VBLK are software set and programmable to the CLK pixel count. This allows any possible alignment to the internal pixel count and line count. The default settings for a 525-/625-line video output are shown in [Figure 4-1](#).

TVP5154
4-CHANNEL LOW-POWER PAL/NTSC/SECAM VIDEO DECODER
WITH INDEPENDENT SCALERS AND FAST LOCK

SLES163A—MARCH 2006—REVISED JULY 2006

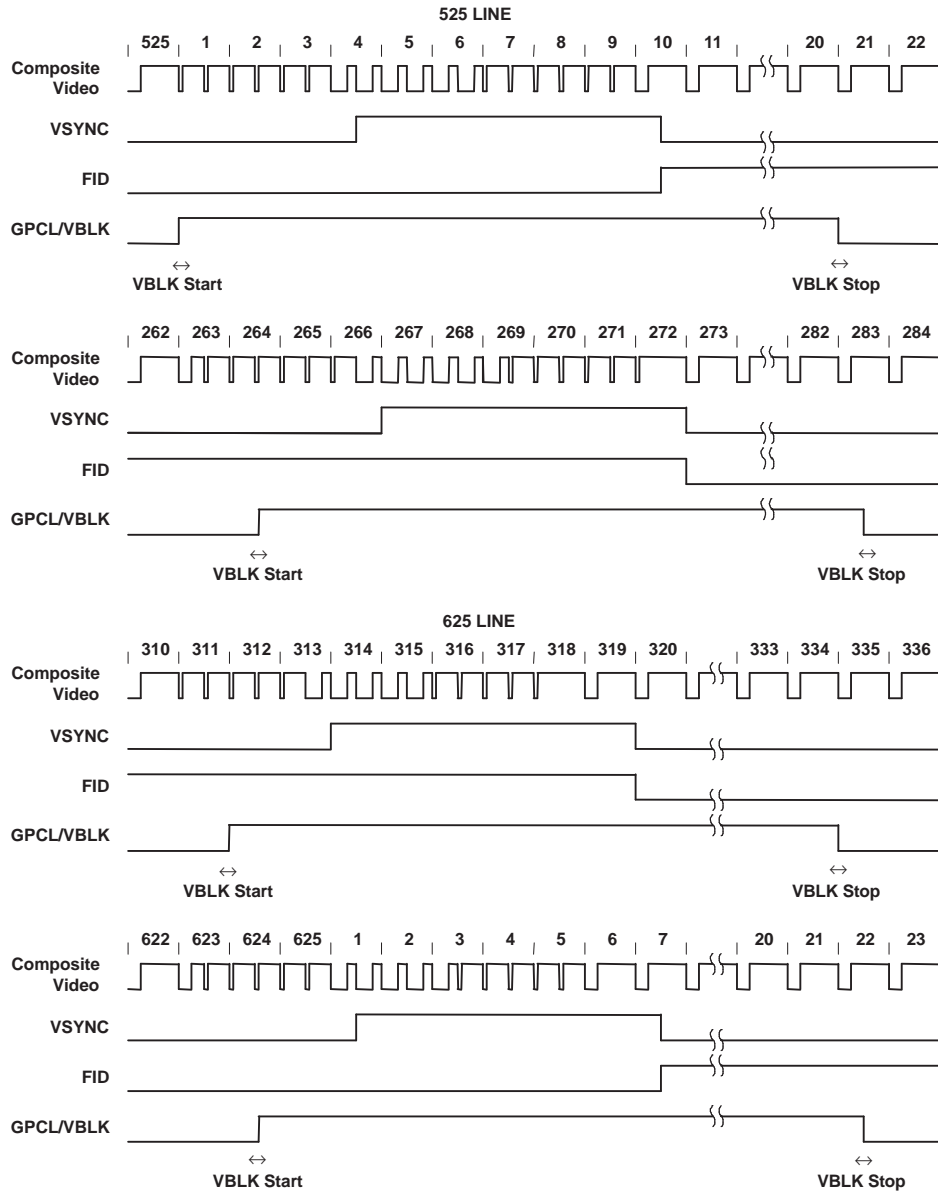

Line numbering conforms to ITU-R BT.470.

Figure 4-1. 8-Bit 4:2:2, Timing With 2× Pixel Clock (CLK) Reference

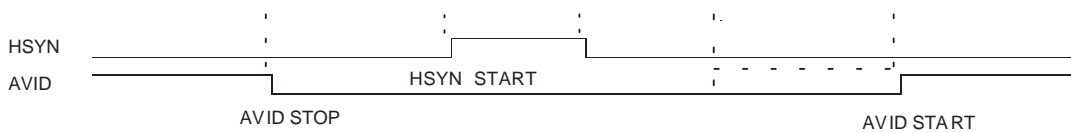

NOTE: AVID rising edge occurs four CLK cycles early when in ITU-R BT.656 output mode.

Figure 4-2. Horizontal Synchronization Signals

4.13 Active Video (AVID) Cropping

AVID cropping provides a means to decrease the amount of video data output. This is accomplished by horizontally blanking a number of AVID pulses and by vertically blanking a number of lines per frame. The horizontal AVID cropping is controlled using registers 11h and 12h for start pixels MSB and LSB, respectively.

Registers 13h and 14h provide access to stop pixels MSB and LSB, respectively. The vertical AVID cropping is controlled using the vertical blanking (VBLK) start and stop registers at addresses 18h and 19h. [Figure 4-3](#) shows an AVID application.

AVID cropping can be independently controlled for scaled (registers 25h, 26h, 29h, and 2Ah) and unscaled (registers 11h thru 14h) data streams. AVID start and stop must be changed in multiples of two pixels to ensure correct UV alignment.

Additionally, AVID start and stop can be configured to include the SAV- and EAV-embedded sync signals or to exclude them, and to either include or exclude ITU656 ancillary data.

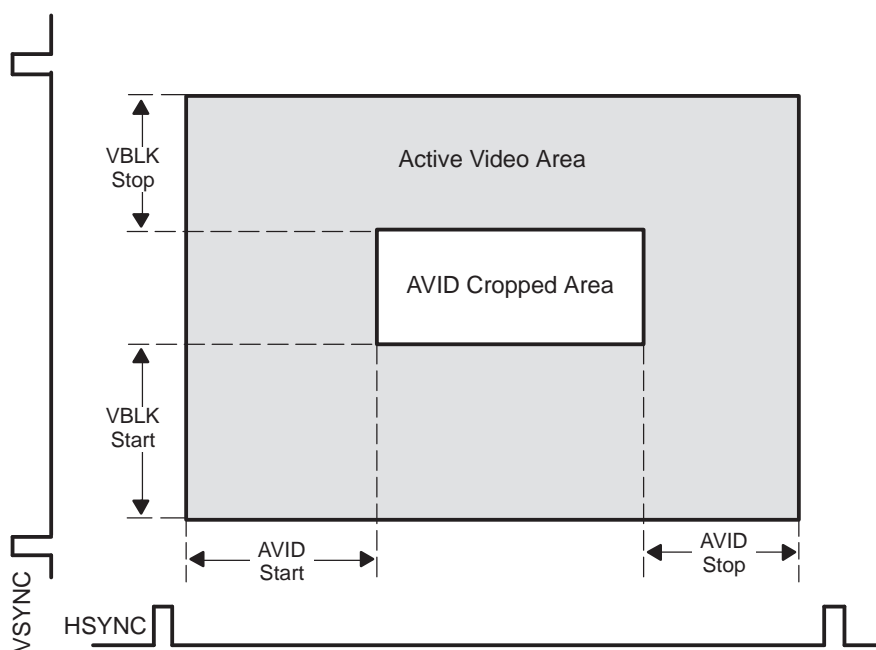

Figure 4-3. AVID Application

4.14 Embedded Syncs

Standards with embedded syncs insert SAV and EAV codes into the data stream at the beginning and end of horizontal blanking. These codes contain the V and F bits that also define vertical timing. F and V change on EAV. [Table 4-4](#) gives the format of the SAV and EAV codes.

H equals 1 always indicates EAV. H equals 0 always indicates SAV. The alignment of V and F to the line and field counter varies depending on the standard. Please refer to ITU-R BT.656 for more information on embedded syncs.

The P bits are protection bits:

- P3 = V x or
- H P2 = F x or
- H P1 = F x or
- V P0 = F x or
- V x or H

Table 4-4. EAV and SAV Sequence

	8-BIT DATA							
	D7 (MSB)	D6	D5	D4	D3	D2	D1	D0
Preamble	1	1	1	1	1	1	1	1
Preamble	0	0	0	0	0	0	0	0
Preamble	0	0	0	0	0	0	0	0
Status word	1	F	V	H	P3	P2	P1	P0

The status word may be modified in order to pass information about whether the current data corresponds to scaled or unscaled data. See register 1Fh for more information.

4.15 Clock and Data Control

Figure 4-4 shows a logical schematic of the data and clock control signals.

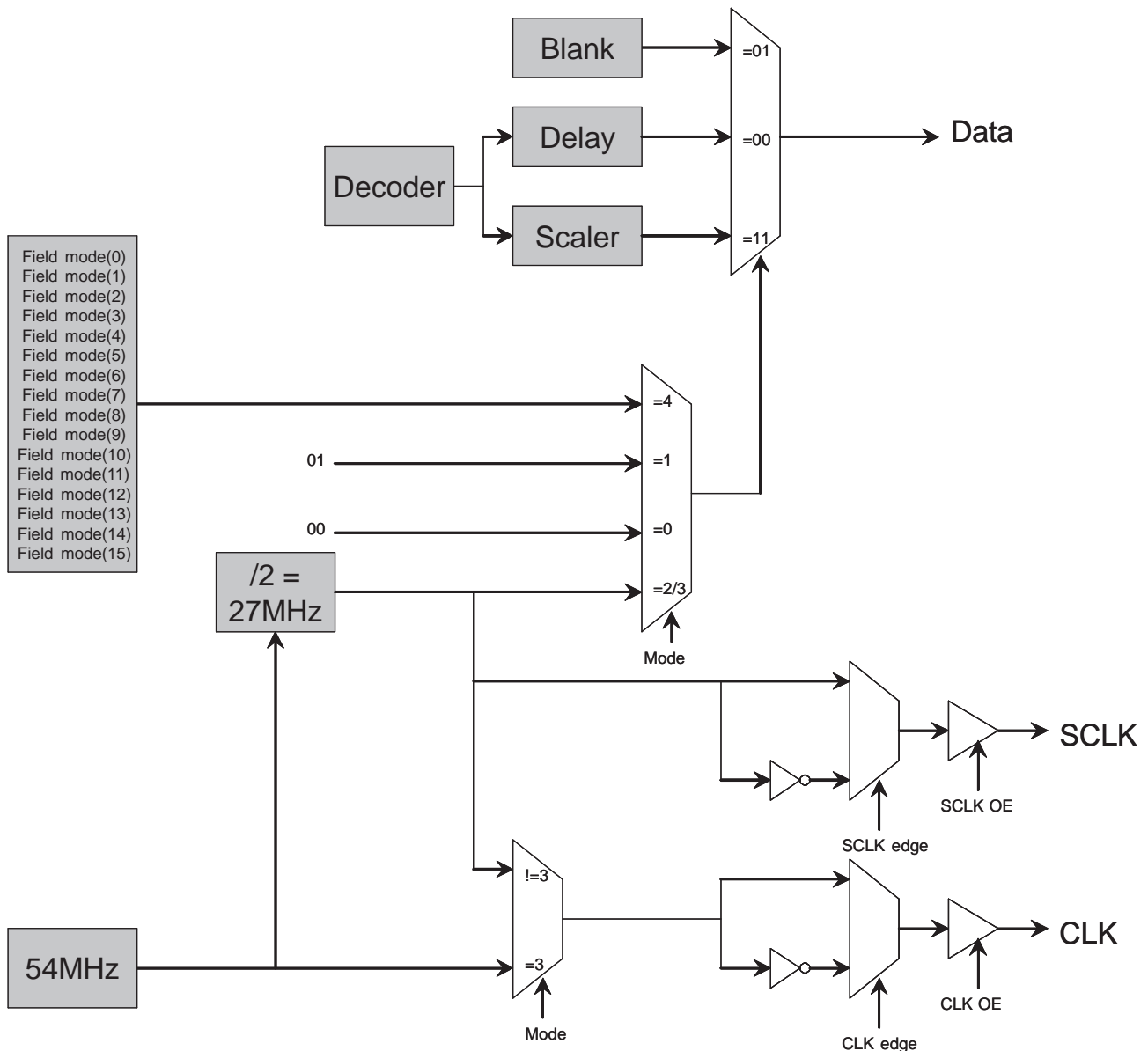

Figure 4-4. Clock and Data Control

5 I²C Host Interface

The I²C standard consists of two signals, serial input/output data line (SDA) and input/output clock line (SCL), which carry information between the devices connected to the bus. The input pins I2CA0 and I2CA1 are used to select the slave address to which the device responds. Although the I²C system can be multimastered, the TVP5154 decoder functions as a slave device only.

Both SDA and SCL must be connected to IOVDD via pullup resistors. When the bus is free, both lines are high. The slave address select terminals (I2CA0 and I2CA1) enable the use of four TVP5154 decoders on the same I²C bus. At the trailing edge of reset, the status of the I2CA0 and I2CA1 lines are sampled to determine the device address used. [Table 5-1](#) summarizes the terminal functions of the I²C-mode host interface. [Table 5-2](#) shows the device address selection options.

Table 5-1. I²C Terminal Description

SIGNAL	TYPE	DESCRIPTION
I2CA0	I	Slave address selection
I2CA1	I	Slave address selection
SCL	I/O (open drain)	Input/output clock line
SDA	I/O (open drain)	Input/output data line

Table 5-2. I²C Host Interface Device Addresses

A6	A5	A4	A3	A2	A1 (I2CA1)	A0 (I2CA0)	R/W	HEX
1	0	1	1	1	0	0	1/0	B9/B8
1	0	1	1	1	0	1	1/0	BB/BA
1	0	1	1	1	1	0	1/0	BD/BC
1	0	1	1	1	1	1	1/0	BF/BE

Data transfer rate on the bus is up to 400 kbit/s. The number of interfaces connected to the bus is dependent on the bus capacitance limit of 400 pF. The data on the SDA line must be stable during the high period of the SCL, except for start and stop conditions. The high or low state of the data line can only change with the clock signal on the SCL line being low. A high-to-low transition on the SDA line while the SCL is high indicates an I²C start condition. A low-to-high transition on the SDA line while the SCL is high indicates an I²C stop condition.

Every byte placed on the SDA must be eight bits long. The number of bytes that can be transferred is unrestricted. Each byte must be followed by an acknowledge bit. The acknowledge-related clock pulse is generated by the I²C master.

To simplify programming of each of the four decoder channels, a single I²C write transaction can be transmitted to any one or more of the four cores in parallel. This reduces the time required to download firmware or to configure the device when all channels are to be configured in the same manner. It also enables the addresses for all registers to be common across all decoders.

I²C sub-address 0xFE contains four bits, with each bit corresponding to one of the decoder cores. If this bit is set, I²C write transactions are sent to the corresponding decoder core. If the bit is 0, the corresponding decoder does not receive the I²C write transactions.

I²C sub-address 0xFF contains four bits, with each bit corresponding to one of the decoder cores. If this bit is set, I²C read transactions are sent to the corresponding decoder core. Note, only one of the bits in this register should be set at a given time, ensuring that only one decoder core is accessed at a time for read operations. If more than one bit is set, the lowest set bit number corresponds to the core that responds to the read transaction.

Note, when register 0xFE is written to with any value, register 0xFF is set to 0x00. Likewise, when register 0xFF is written to with any value, register 0xFE is set to 0x00.

5.1 I²C Write Operation

Data transfers occur utilizing the following illustrated formats.

An I²C master initiates a write operation to the TVP5154 decoder by generating a start condition (S) followed by the TVP5154 I²C address (as shown below), in MSB first bit order, followed by a 0 to indicate a write cycle. After receiving an acknowledge from the TVP5154 decoder, the master presents the sub-address of the register, or the first of a block of registers it wants to write, followed by one or more bytes of data, MSB first. The TVP5154 decoder acknowledges each byte after completion of each transfer. The I²C master terminates the write operation by generating a stop condition (P).

Step 1	0							
I ² C start (master)	S							
Step 2	7	6	5	4	3	2	1	0
I ² C general address (master)	1	0	1	1	1	0	X	0
Step 3	9							
I ² C acknowledge (slave)	A							
Step 4	7	6	5	4	3	2	1	0
I ² C write register address (master)	addr	addr	addr	addr	addr	addr	addr	addr
Step 5	9							
I ² C acknowledge (slave)	A							
Step 6	7	6	5	4	3	2	1	0
I ² C write data (master)	Data	Data	Data	Data	Data	Data	Data	Data
Step 7⁽¹⁾	9							
I ² C acknowledge (slave)	A							
Step 8	0							
I ² C stop (master)	P							

(1) Repeat steps 6 and 7 until all data have been written.

5.2 I²C Read Operation

The read operation consists of two phases. The first phase is the address phase. In this phase, an I²C master initiates a write operation to the TVP5154 decoder by generating a start condition (S) followed by the TVP5154 I²C address, in MSB first bit order, followed by a 0 to indicate a write cycle. After receiving acknowledges from the TVP5154 decoder, the master presents the sub-address of the register or the first of a block of registers it wants to read. After the cycle is acknowledged, the master terminates the cycle immediately by generating a stop condition (P).

The second phase is the data phase. In this phase, an I²C master initiates a read operation to the TVP5154 decoder by generating a start condition followed by the TVP5154 I²C address (as shown below for a read operation), in MSB first bit order, followed by a 1 to indicate a read cycle. After an acknowledge from the TVP5154 decoder, the I²C master receives one or more bytes of data from the TVP5154 decoder. The I²C master acknowledges the transfer at the end of each byte. After the last data byte desired has been transferred from the TVP5154 decoder to the master, the master generates a not acknowledge followed by a stop.

Read Phase 1

Step 1	0							
I ² C start (master)	S							
Step 2	7	6	5	4	3	2	1	0
I ² C general address (master)	1	0	1	1	1	0	X	0
Step 3	9							
I ² C acknowledge (slave)	A							
Step 4	7	6	5	4	3	2	1	0
I ² C read register address (master)	addr	addr	addr	addr	addr	addr	addr	addr
Step 5	9							
I ² C acknowledge (slave)	A							
Step 6	0							
I ² C stop (master)	P							

Read Phase 2

Step 7	0							
I ² C start (master)	S							
Step 8	7	6	5	4	3	2	1	0
I ² C general address (master)	1	0	1	1	1	0	X	1
Step 9	9							
I ² C acknowledge (slave)	A							
Step 10	7	6	5	4	3	2	1	0
I ² C read data (slave)	Data	Data	Data	Data	Data	Data	Data	Data
Step 11⁽¹⁾	9							
I ² C not acknowledge (master)	A							
Step 12	0							
I ² C stop (master)	P							

(1) Repeat steps 10 and 11 for all bytes read. Master does not acknowledge the last read data received.

5.2.1 I²C Timing Requirements

The TVP5154 decoder requires delays in the I²C accesses to accommodate its internal processor's timing. In accordance with I²C specifications, the TVP5154 decoder holds the I²C clock line (SCL) low to indicate the wait period to the I²C master. If the I²C master is not designed to check for the I²C clock line held-low condition, the maximum delays must always be inserted where required. These delays are of variable length; maximum delays are indicated in the following diagram:

Table 5-3. I²C Timing

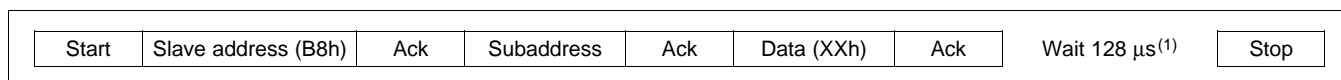

(1) If the SCL pin is not monitored by the master to enable pausing, a delay of 128 μs should be inserted between transactions for registers 00h through 8Fh.

6 Clock Circuits

An internal line-locked PLL generates the system and pixel clocks. A 14.31818-MHz clock is required to drive the PLL. This may be input to the TVP5154 decoder on terminal 124 (XIN), or a crystal of 14.31818-MHz fundamental resonant frequency may be connected across terminals 123 and 124 (XIN and XOUT). [Figure 6-1](#) shows the reference clock configurations. For the example crystal circuit shown (a parallel-resonant crystal with 14.31818-MHz fundamental frequency), the external capacitors must have the following relationship:

$$C_{L1} = C_{L2} = 2C_L - C_{STRAY}$$

where C_{STRAY} is the terminal capacitance with respect to ground. [Figure 6-1](#) shows the reference clock configurations.

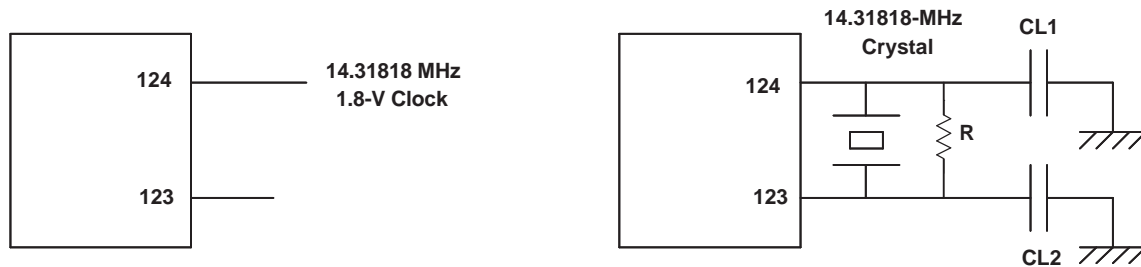

Figure 6-1. Clock and Crystal Connectivity

7 Genlock Control and RTC

A Genlock control (GLCO) function is provided to support a standard video encoder to synchronize its internal color oscillator for properly reproduced color with unstable timebase sources like VCRs.

The frequency control word of the internal color subcarrier digital control oscillator (DTO) and the subcarrier phase reset bit are transmitted via the GLCO terminal. The frequency control word is a 23-bit binary number. The frequency of the DTO can be calculated from the following equation:

$$F_{dto} = \frac{F_{ctrl}}{2^{23}} \times F_{clk} \quad (1)$$

where F_{dto} is the frequency of the DTO, F_{ctrl} is the 23-bit DTO frequency control, and F_{clk} is the frequency of the CLK.

7.1 TVP5154 Genlock Control Interface

A write of 1 to bit 4 of the chrominance control register at I²C subaddress 1Ah causes the subcarrier DTO phase reset bit to be sent on the next scan line on GLCO. The active-low reset bit occurs seven CLKs after the transmission of the last bit of DCO frequency control. Upon the transmission of the reset bit, the phase of the TVP5154 internal subcarrier DCO is reset to zero.

A Genlock slave device can be connected to the GLCO terminal and uses the information on GLCO to synchronize its internal color phase DCO to achieve clean line and color lock.

7.2 RTC Mode

[Figure 7-1](#) shows the timing diagram of the RTC mode. Clock rate for the RTC mode is four times slower than the GLCO clock rate. For PLL frequency control, the upper 22 bits are used. Each frequency control bit is two clock cycles long. The active-low reset bit occurs six CLKs after the transmission of the last bit of PLL frequency control.

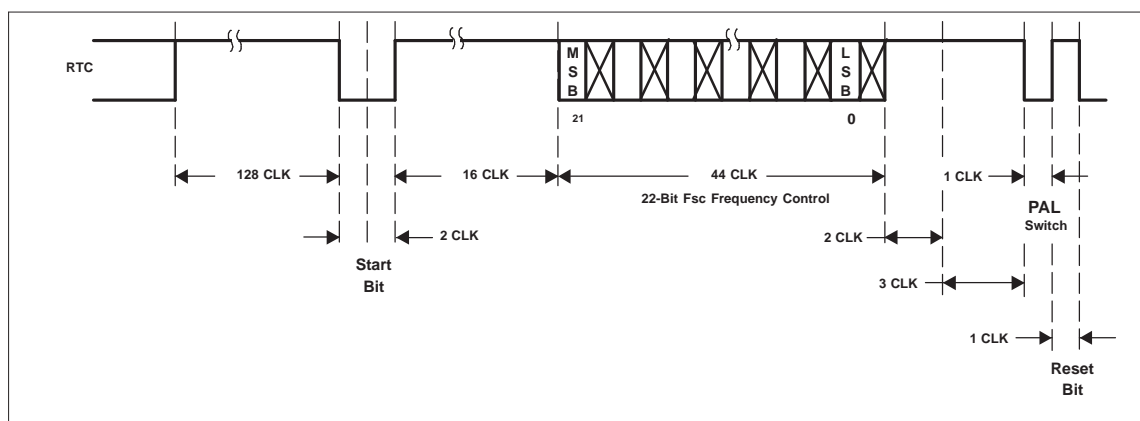
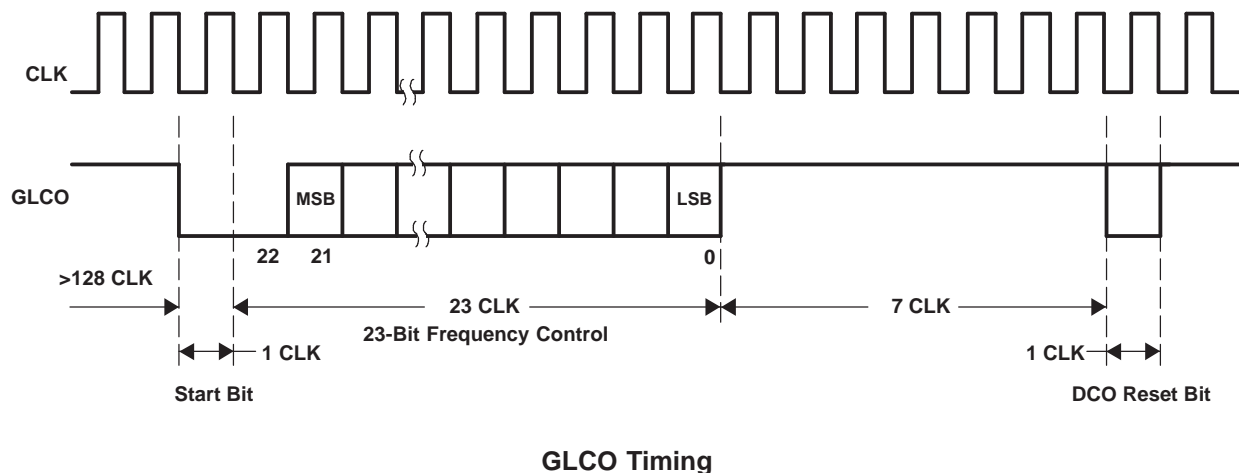

Figure 7-1. RTC Timing

8 Power-Up, Reset, and Power-Down Sequence (Required)

Terminals 121 (RESETB) and 122 (PDN) work together to put the TVP5154 decoder into one of three modes. [Table 8-1](#) shows the configuration.

After power up, the device is in an unknown state with its outputs undefined until it receives a RESETB active low for at least 200 ns. The power supplies should be active and stable for 10 ms before RESETB becomes inactive. There are no power-sequencing requirements, except that all power supplies should become active and stable within 500 ms of each other.

After each power-up and hardware reset, this procedure must be followed:

1. Wait at least 1 ms. Each decoder must be started by writing 0x00h to register 7Fh for all four decoders.
2. Wait at least 1 ms. Check the status of the TVP5154 by doing an I²C read of the version number, register 81h, for all four decoders.
3. Verify that the value 0x54h is read.
4. If the value 0x54h is **not** read, toggle the TVP5154 reset pin (RESETB, pin number 121).

This procedure should be repeated if necessary until the value 0x54h is read from register 81h for all four decoders.

Table 8-1. Reset and Power-Down Modes

PDN	RESETB	CONFIGURATION
0	0	Reserved (undefined state)
0	1	Powers down the decoder
1	0	Resets the decoder
1	1	Normal operation

9 Internal Control Registers

9.1 Overview

The TVP5154 decoder is initialized and controlled by sets of internal registers that set all device operating parameters. Communication between the external controller and the TVP5154 decoder is through the I²C. Two sets of registers exist, direct and indirect. Table 9-1 shows the summary of the direct registers. Reserved registers must not be written. Reserved bits in the defined registers must be written with 0s, unless otherwise noted. The detailed programming information of each register is described in the following sections.

I²C register 0xFE controls which of the four decoders receives I²C commands. I²C register 0xFF controls which decoder core responds to I²C reads. Note, for a read operation, it is necessary to perform a write first, in order to set the desired sub-address for reading.

After power up and the hardware reset, each decoder must be started by writing 0x00h to register 7Fh for all four decoders.

Table 9-1. Direct Register Summary

REGISTER FUNCTION	ADDRESS	DEFAULT	R/W ⁽¹⁾
Video input source selection #1	00h	00h	R/W
Analog channel controls	01h	15h	R/W
Operation mode controls	02h	00h	R/W
Miscellaneous controls	03h	01h	R/W
Autoswitch mask	04h	DCh	R/W
Clock control	05h	08h	R/W
Color killer threshold control	06h	10h	R/W
Luminance processing control #1	07h	60h	R/W
Luminance processing control #2	08h	00h	R/W
Brightness control	09h	80h	R/W
Color saturation control	0Ah	80h	R/W
Hue control	0Bh	00h	R/W
Contrast control	0Ch	80h	R/W
Outputs and data rates select	0Dh	47h	R/W
Luminance processing control #3	0Eh	00h	R/W
Configuration shared pins	0Fh	08h	R/W
Reserved	10h		
Active video cropping start MSB for unscaled data	11h	00h	R/W
Active video cropping start LSB for unscaled data	12h	00h	R/W
Active video cropping stop MSB for unscaled data	13h	00h	R/W
Active video cropping stop LSB for unscaled data	14h	00h	R/W
Genlock/RTC	15h	01h	R/W
Horizontal sync start	16h	80h	R/W

(1) R = Read only, W = Write only, R/W = Read and write

Table 9-1. Direct Register Summary (continued)

REGISTER FUNCTION	ADDRESS	DEFAULT	R/W ⁽¹⁾
Ancillary SAV/EAV control	17h	52h	R/W
Vertical blanking start	18h	00h	R/W
Vertical blanking stop	19h	00h	R/W
Chrominance processing control #1	1Ah	0Ch	R/W
Chrominance processing control #2	1Bh	14h	R/W
Interrupt reset register B	1Ch	00h	R/W
Interrupt enable register B	1Dh	00h	R/W
Interrupt configuration register B	1Eh	00h	R/W
Output control	1Fh	00h	R/W
Reserved	20h		
I ² C indirect registers	21h–24h	00h	R/W
AVID start/control for scaled data	25h–26h	00h	R/W
Reserved	27h		
Video standard	28h	00h	R/W
AVID stop for scaled data	29h–2Ah	00h	R/W
Reserved	2Bh		
Cb gain factor	2Ch		R
Cr gain factor	2Dh		R
Reserved	2Eh–2Fh		
656 Revision Select	30	00h	R/W
Reserved	31h–7Fh		
MSB of device ID	80h	51h	R
LSB of device ID	81h	54h	R
ROM major version	82h	02h	R
ROM minor version	83h	00h	R
Vertical line count MSB	84h		R
Vertical line count LSB	85h		R
Interrupt status register B	86h		R
Interrupt active register B	87h		R
Status register #1	88h		R
Status register #2	89h		R
Status register #3	8Ah		R
Status register #4	8Bh		R
Status register #5	8Ch		R
Reserved	8Dh–8Fh		
Closed caption data registers	90h–93h		R
WSS data registers	94h–99h		R
VPS data registers	9Ah–A6h		R
VITC data registers	A7h–AFh		R
VBI FIFO read data	B0h		R
Teletext filter 1	B1h–B5h	00h	R/W
Teletext filter 2	B6h–BAh	00h	R/W
Teletext filter enable	BBh	00h	R/W
Reserved	BCh–BFh		
Interrupt status register A	C0h	00h	R/W
Interrupt enable register A	C1h	00h	R/W
Interrupt configuration	C2h	04h	R/W

Table 9-1. Direct Register Summary (continued)

REGISTER FUNCTION	ADDRESS	DEFAULT	R/W ⁽¹⁾
VDP configuration RAM data	C3h	B8h	R/W
Configuration RAM address low byte	C4h	1Fh	R/W
Configuration RAM address high byte	C5h	00h	R/W
VDP status register	C6h		R
FIFO word count	C7h		R
FIFO interrupt threshold	C8h	80h	R/W
FIFO reset	C9h	00h	W
Line number interrupt	CAh	00h	R/W
Pixel alignment register low byte	CBh	4Eh	R/W
Pixel alignment register high byte	CCh	00h	R/W
FIFO output control	CDh	01h	R/W
Reserved	CEh		
Full field enable	CFh	00h	R/W
Line mode registers	D0h D1h–FBh	00h FFh	R/W
Full field mode register	FC h	7Fh	R/W
Reserved	FDh		
Decoder core write enables	FEh	0Fh	R/W
Decoder core read enables	FFh	00h	R/W

9.2 Direct Register Definitions

Direct registers are written to by performing a 3-byte I²C transaction:

START : DEVICE_ID : SUB_ADDRESS : DATA : STOP

Each direct register is eight bits wide.

9.2.1 Video Input Source Selection #1 Register

Address	00h						
Default	00h						
7	6	5	4	3	2	1	0
Reserved			Black output	Reserved	Channel n source selection		S-video selection

Channel n source selection:

0 = AIPnA selected (default)

1 = AIPnB selected

Table 9-2. Analog Channel and Video Mode Selection

	INPUT(S) SELECTED	ADDRESS 00	
		BIT 1	BIT 0
Composite	AIPnA (default)	0	0
	AIPnB	1	0
S-Video	AIPnA (luma), AIPnB (chroma)	x	1

Where n = 1, 2, 3, 4

Black output:

- 0 = Normal operation (default)
- 1 = Force black screen output (outputs synchronized)
 - a. Forced to 10h in normal mode
 - b. Forced to 01h in extended mode

9.2.2 Analog Channel Controls Register

Address	01h						
Default	15h						
7	6	5	4	3	2	1	0
Reserved			1	Automatic offset control		Automatic gain control	

Automatic offset control:

- 00 = Disabled
- 01 = Automatic offset enabled (default)
- 10 = Reserved
- 11 = Offset level frozen to the previously set value

Automatic gain control (AGC):

- 00 = Disabled (fixed gain value)
- 01 = AGC enabled (default)
- 10 = Reserved
- 11 = AGC frozen to the previously set value

9.2.3 Operation Mode Controls Register

Address	02h						
Default	00h						

7	6	5	4	3	2	1	0
Fast lock mode	Color burst reference enable	TV/VCR mode		White peak disable	Color subcarrier PLL frozen	Luma peak disable	Power down mode

Fast lock mode:

- 0 = Normal operation (default)
- 1 = Fast lock mode. Locks within three fields if stable input signal and forced video standard.

Color burst reference enable:

- 0 = Color burst reference for AGC disabled (default)
- 1 = Color burst reference for AGC enabled

TV/VCR mode:

- 00 = Automatic mode determined by the internal detection circuit (default)
- 01 = Reserved
- 10 = VCR (nonstandard video) mode
- 11 = TV (standard video) mode

With automatic detection enabled, unstable or nonstandard syncs on the input video forces the detector into the VCR mode. This turns off the comb filters and turns on the chroma trap filter.

White peak disable:

- 0 = White peak protection enabled (default)
- 1 = White peak protection disabled

Color subcarrier PLL frozen:

- 0 = Color subcarrier PLL increments by the internally generated phase increment (default). GLCO pin outputs the frequency increment.
- 1 = Color subcarrier PLL stops operating. GLCO pin outputs the frozen frequency increment.

Luma peak disable

- 0 = Luma peak processing enabled (default)
- 1 = Luma peak processing disabled

Power-down mode:

- 0 = Normal operation (default)
- 1 = Power-down mode. A/Ds are turned off and internal clocks are reduced to minimum.

9.2.4 Miscellaneous Control Register

Address	03h						
Default	01h						
7	6	5	4	3	2	1	0
VBKO	GPCL pin	GPCL output enable	Lock status (HVLK)	YCbCr output enable(TVPOE)	HSYNC, VSYNC/PALI, AVID, FID/GLCO output enable	Vertical blanking on/off	CLK output enable

VBKO (pins 41, 60, 83, 102) function select:

- 0 = GPCL (default)
- 1 = VBLK

Note, if these pins are not configured as outputs, they must not be left floating. A 10-kΩ pulldown resistor is recommended if not driven externally.

GPCL (data is output based on state of bit 5):

- 0 = GPCL outputs 0 (default)
- 1 = GPCL outputs 1

GPCL output enable:⁽¹⁾

- 0 = GPCL is inactive (default).
- 1 = GPCL is output.

Note, if these pins are not configured as outputs, they must not be left floating. A 10-kΩ pulldown resistor is recommended if not driven externally.

⁽¹⁾GPCL should not be programmed to be 0 when register 0Fh bit 1 is '1 (programmed to be GPCL/VBLK).

Lock status (HVLK) (configured along with register 0Fh, see [Figure 9-1](#) for the relationship between the configuration shared pins):

- 0 = Terminal VSYNC/PALI outputs the PAL indicator (PALI) signal and terminal FID/GLCO outputs the field ID (FID) signal (default) (if terminals are configured to output PALI and FID in register 0Fh).
- 1 = Terminal VSYNC/PALI outputs the horizontal lock indicator (HLK) and terminal FID outputs the vertical lock indicator (VLK) (if terminals are configured to output PALI and FID in register 0Fh).

These are additional functionalities that are provided for ease of use.

YCbCr output enable:

- 0 = YOUT[7:0] high impedance (default)
- 1 = YOUT[7:0] active

Note, if these pins are not configured as outputs, they must not be left floating. A 10-kΩ pulldown resistor is recommended if not driven externally.

HSYNC, VSYNC/PALI, active video indicator (AVID), and FID/GLCO output enables:

- 0 = HSYNC, VSYNC/PALI, AVID, and FID/GLCO are high impedance (default).
- 1 = HSYNC, VSYNC/PALI, AVID, and FID/GLCO are active.

Note, if these pins are not configured as outputs, they must not be left floating. A 10-kΩ pulldown resistor is recommended if not driven externally.

Vertical blanking on/off:

- 0 = Vertical blanking (VBLK) off (default)
- 1 = Vertical blanking (VBLK) on

CLK output enable:

- 0 = CLK output is high impedance.
- 1 = CLK output is enabled (default).

Note: CLK edge and SCLK are configured through register 05h.

Table 9-3. Digital Output Control

REGISTER 03h, BIT 3 (TVPOE) ⁽¹⁾	REGISTER C2h, BIT 2 (VDPOE) ⁽¹⁾	YCbCr OUTPUT
0	X	High impedance
X	0	High impedance
1	1	Active

(1) VDPOE default is 1 and TVPOE default is 0.

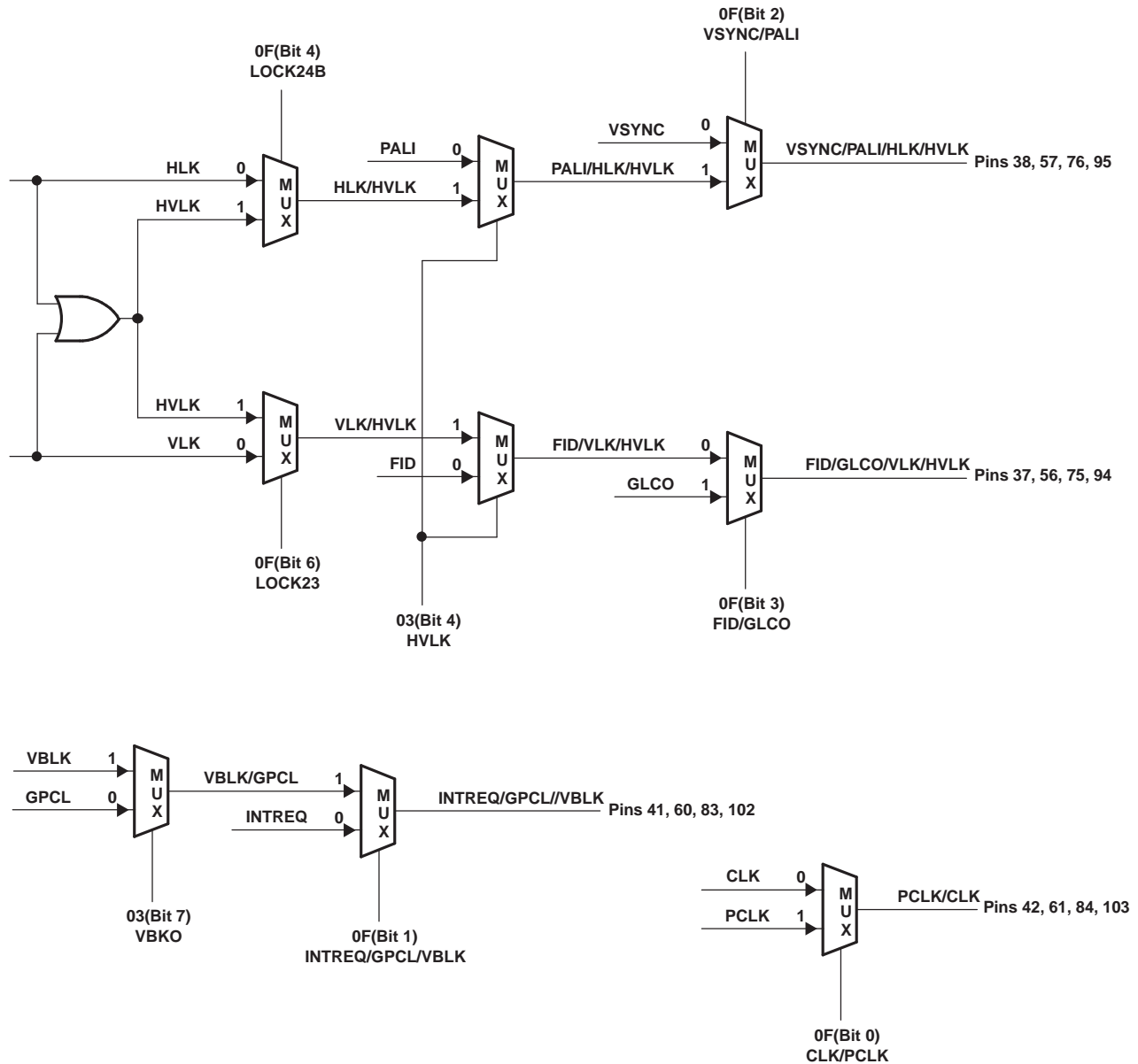

NOTE: Also refer to the configuration shared pins register at subaddress 0Fh.

Figure 9-1. Configuration Shared Pins

9.2.5 Autoswitch Mask Register

Address	04h	
Default	DCh	

7	6	5	4	3	2	1	0
Reserved		SEC_OFF	N443_OFF	PALN_OFF	PALM_OFF	Reserved	

N443_OFF:

- 0 = NTSC443 is unmasked from the autoswitch process. Autoswitch does switch to NTSC443.
- 1 = NTSC443 is masked from the autoswitch process. Autoswitch does not switch to NTSC443 (default).

PALN_OFF:

- 0 = PAL-N is unmasked from the autoswitch process. Autoswitch does switch to PAL-N.
- 1 = PAL-N is masked from the autoswitch process. Autoswitch does not switch to PAL-N (default).

PALM_OFF:

- 0 = PAL-M is unmasked from the autoswitch process. Autoswitch does switch to PAL-M.
- 1 = PAL-M is masked from the autoswitch process. Autoswitch does not switch to PAL-M (default).

SEC_OFF:

- 0 = SECAM is unmasked from the autoswitch process. Autoswitch does switch to SECAM (default).
- 1 = SECAM is masked from the autoswitch process. Autoswitch does not switch to SECAM.

9.2.6 Clock Control Register

Address	05h	
Default	08h	

7	6	5	4	3	2	1	0
Reserved				SCLK OE	Reserved	SCLK edge	CLK edge

CLK edge

- 0 = CLK data changes on falling edge of CLK.
- 1 = CLK data changes on rising edge of CLK.

SCLK edge

- 0 = SCLK data changes on falling edge of SCLK.
- 1 = SCLK data changes on rising edge of SCLK.

SCLK OE

- 0 = SCLK output disabled. Output is high impedance.
- 1 = SCLK output enabled.

NOTE: CLK OE is configured through register 0x03 to maintain compatibility with the TVP5150 family of devices.

9.2.7 Color Killer Threshold Control Register

Address	06h	
Default	10h	

7	6	5	4	3	2	1	0
Reserved	Automatic color killer		Color killer threshold				

Automatic color killer:

- 00 = Automatic mode (default)
- 01 = Reserved
- 10 = Color killer enabled, the CbCr terminals are forced to a zero color state.
- 11 = Color killer disabled

Color killer threshold:

- 11111 = -30 dB (minimum)
- 10000 = -24 dB (default)
- 00000 = -18 dB (maximum)

9.2.8 Luminance Processing Control #1 Register

Address	07h	
Default	60h	

7	6	5	4	3	2	1	0
2× luma output enable	Pedestal not present	Disable raw header	Luma bypass enabled during vertical blanking	Luminance signal delay with respect to chrominance signal			

2× luma output enable:

- 0 = Output depends on bit 4, luminance bypass enabled during vertical blanking (default).
- 1 = Outputs 2× luma samples during the entire frame. This bit takes precedence over bit 4.

Pedestal not present:

- 0 = 7.5 IRE pedestal is present on the analog video input signal.
- 1 = Pedestal is not present on the analog video input signal (default).

Disable raw header:

- 0 = Insert 656 ancillary headers for raw data
- 1 = Disable 656 ancillary headers and instead force dummy ones (0x40) (default)

Luminance bypass enabled during vertical blanking:

- 0 = Disabled. If bit 7, 2× luma output enable, is 0, normal luminance processing occurs and YCbCr samples are output during the entire frame (default).
- 1 = Enabled. If bit 7, 2× luma output enable, is 0, normal luminance processing occurs and YCbCr samples are output during VACTIVE and 2× luma samples are output during VBLK. Luminance bypass occurs for the duration of the vertical blanking as defined by registers 18h and 19h.

Luma signal delay with respect to chroma signal in pixel clock increments (range –8 to 7 pixel clocks):

- 1111 = –8 pixel clocks delay
- 1011 = –4 pixel clocks delay
- 1000 = –1 pixel clocks delay
- 0000 = 0 pixel clocks delay (default)
- 0011 = 3 pixel clocks delay
- 0111 = 7 pixel clocks delay

9.2.9 Luminance Processing Control #2 Register

Address	08h	
Default	00h	

7	6	5	4	3	2	1	0
Reserved	Luminance filter select	Reserved		Peaking gain		Reserved	

Luminance filter select:

- 0 = Luminance comb filter enabled (default)
- 1 = Luminance chroma trap filter enabled

Peaking gain (sharpness):

- 00 = 0 (default)
- 01 = 0.5
- 10 = 1
- 11 = 2

Information on peaking frequency: ITU-R BT.601 sampling rate: all standards — peaking center frequency is 2.6 MHz

9.2.10 Brightness Control Register

Address	09h	
Default	80h	

7	6	5	4	3	2	1	0
Brightness control							

Brightness control:

- 1111 1111 = 255 (bright)
- 1000 0000 = 128 (default)
- 0000 0000 = 0 (dark)

9.2.11 Color Saturation Control Register

Address	0Ah						
Default	80h						
7	6	5	4	3	2	1	0
Saturation control							

Saturation control:

1111 1111 = 255 (maximum)
 1000 0000 = 128 (default)
 0000 0000 = 0 (no color)

9.2.12 Hue Control Register (does not apply to SECAM)

Address	0Bh						
Default	00h						
7	6	5	4	3	2	1	0
Hue control							

Hue control:

0111 1111 = +180 degrees
 0000 0000 = 0 degrees (default)
 1000 0000 = – 180 degrees

9.2.13 Contrast Control Register

Address	0Ch						
Default	80h						
7	6	5	4	3	2	1	0
Contrast control							

Contrast control:

1111 1111 = 255 (maximum contrast)
 1000 0000 = 128 (default)
 0000 0000 = 0 (minimum contrast)

TVP5154

4-CHANNEL LOW-POWER PAL/NTSC/SECAM VIDEO DECODER WITH INDEPENDENT SCALERS AND FAST LOCK

SLES163A—MARCH 2006—REVISED JULY 2006

9.2.14 Outputs and Data Rates Select Register

Address	0Dh	
Default	47h	

7	6	5	4	3	2	1	0
Reserved	YCbCr output code range	CbCr code format	YCbCr data path bypass	YCbCr output format			

YCbCr output code range:

0 = ITU-R BT.601 coding range (Y ranges from 16 to 235. U and V range from 16 to 240)

1 = Extended coding range (Y, U, and V range from 1 to 254) (default)

CbCr code format:

0 = Offset binary code (2s complement + 128) (default)

1 = Straight binary code (2s complement)

YCbCr data path bypass:

00 = Normal operation (default)

01 = Decimation filter output connects directly to the YCbCr output pins. This data is similar to the digitized composite data, but the HBLANK area is replaced with ITU-R BT.656 digital blanking.

10 = Digitized composite (or digitized S-video luma). A/D output connects directly to the YCbCr output pins.

11 = Reserved

YCbCr output format:

000 = 8-bit 4:2:2 YCbCr with discrete sync output

001 = Reserved

010 = Reserved

011 = Reserved

100 = Reserved

101 = Reserved

110 = Reserved

111 = 8-bit ITU-R BT.656 interface with embedded sync output (default)

9.2.15 Luminance Processing Control #3 Register

Address	0Eh	
Default	00h	

7	6	5	4	3	2	1	0
Reserved						Luminance trap filter select	

Luminance filter stop band bandwidth (MHz):

00 = No notch (default)

01 = Notch 1

10 = Notch 2

11 = Notch

Luminance filter select [1:0] selects one of the four chroma trap (notch) filters to produce luminance signal by removing the chrominance signal from the composite video signal. The stopband of the chroma trap filter is centered at the chroma subcarrier frequency, with stopband bandwidth controlled by the two control bits. Refer to [Table 9-4](#) for the stopband bandwidths. The WCF bit is controlled in the chrominance control #2 register.

Table 9-4. Luma Filter Selection

WCF	FILTER SELECT	NTSC/PAL/SECAM ITU-R BT.601
0	00	1.2214
	01	0.8782
	10	0.7297
	11	0.4986
1	00	1.4170
	01	1.0303
	10	0.8438
	11	0.5537

9.2.16 Configuration Shared Pins Register

Address	0Fh
Default	08h

7	6	5	4	3	2	1	0
Reserved	FID PIN	Reserved	PALI PIN	FID/GLCO	VSYNC/PALI	INTREQ/GPCL/VBLK	CLK/PCLK

FID PIN function select:

- 0 = FID (default, if bit 3 is selected to output FID)
- 1 = Lock indicator (indicates whether the device is locked vertically)

PALI PIN function select:

- 0 = PALI (default, if bit 2 is selected to output PALI)
- 1 = Lock indicator (indicates whether the device is locked horizontally)

FID/GLCO function select (also refer to register 03h for enhanced functionality):

- 0 = FID
- 1 = GLCO (default)

VSYNC/PALI function select (also refer to register 03h for enhanced functionality):

- 0 = VSYNC (default)
- 1 = PALI

INTREQ/GPCL/VBLK function select:

- 0 = INTREQ (default)
- 1 = GPCL or VBLK depending on bit 7 of register 03h

CLK/PCLK (pins 42, 61, 84, 103) function select:

- 0 = CLK at 27 MHz (default)
- 1 = PCLK (1× pixel clock frequency at 13.5 MHz)

See Figure 9-1 for the relationship between the configuration shared pins.

9.2.17 Active Video Cropping Start Pixel MSB for Unscaled Data Register

Address	11h
Default	00h

7	6	5	4	3	2	1	0
AVID start pixel MSB [9:2]							

Active video cropping start pixel MSB [9:2], set this register first before setting register 12h. The TVP5154 decoder updates the AVID start values only when register 12h is written to. This start pixel value is relative to the default values of the AVID start pixel.

TVP5154
4-CHANNEL LOW-POWER PAL/NTSC/SECAM VIDEO DECODER
WITH INDEPENDENT SCALERS AND FAST LOCK



SLES163A–MARCH 2006–REVISED JULY 2006

9.2.18 Active Video Cropping Start Pixel LSB for Unscaled Data Register

Address	12h	
Default	00h	

7	6	5	4	3	2	1	0
Reserved					AVID active	AVID start pixel LSB [1:0]	

AVID active:

- 0 = AVID out active in VBLK (default)
- 1 = AVID out inactive in VBLK

AVID start [9:0] (combined registers 11h and 12h):

- 01 1111 1111 = 511
- 00 0000 0001 = 1
- 00 0000 0000 = 0 (default)
- 11 1111 1111 = - 1
- 10 0000 0000 = - 512

Active video cropping start pixel LSB [1:0]: The TVP5154 decoder updates the AVID start values only when this register is written to.

9.2.19 Active Video Cropping Stop Pixel MSB LSB for Unscaled Data Register

Address	13h	
Default	00h	

7	6	5	4	3	2	1	0
AVID stop pixel MSB [9:2]							

Active video cropping stop pixel MSB [9:2], set this register first before setting the register 14h. The TVP5154 decoder updates the AVID stop values only when register 14h is written to. This stop pixel value is relative to the default values of the AVID stop pixel.

9.2.20 Active Video Cropping Stop Pixel LSB for Unscaled Data Register

Address	14h	
Default	00h	

7	6	5	4	3	2	1	0
Reserved						AVID stop pixel LSB [1:0]	

Active video cropping stop pixel LSB [1:0]: The number of pixels of active video must be an even number. The TVP5154 decoder updates the AVID stop values only when this register is written to.

AVID stop [9:0] (combined registers 13h and 14h):

- 01 1111 1111 = 511
- 00 0000 0001 = 1
- 00 0000 0000 = 0 (default) (see [Figure 4-2](#)) and [Figure 4-3](#))
- 11 1111 1111 = - 1
- 10 0000 0000 = - 512

9.2.21 Genlock and RTC Register

Address	15h	
Default	01h	

7	6	5	4	3	2	1	0
Stable syncs	Reserved	F/V bit control	Auto inc	GLCO/RTC			

Stable syncs

0 = Output F and V bits follow the input signal producing fixed vertical blanking periods by adapting the active video.

1 = Output F and V bits produce fixed active video periods by adapting the vertical blanking.

F/V bit control

Table 9-5. F/V Bit Control

BIT 5	BIT 4	NUMBER OF LINES	F BIT	V BIT
0	0	Standard	ITU-R BT.656	ITU-R BT.656
		Nonstandard even	Force to 1	Switch at field boundary
		Nonstandard odd	Toggles	Switch at field boundary
0	1	Standard	ITU-R BT.656	ITU-R BT.656
		Nonstandard	Toggles	Switch at field boundary
1	0	Standard	ITU-R BT.656	ITU-R BT.656
		Nonstandard	Pulse mode	Switch at field boundary
1	1	Illegal		

Auto inc: When this bit is set to 1, subsequent reading/writing from/to back door registers automatically increment the address index.

GLCO/RTC: [Table 9-6](#) for different modes.

Table 9-6. GLCO/RTC Control

BIT 2	BIT 1	BIT 0	GENLOCK/RTC MODE
0	x	0	GLCO
0	x	1	RTC output mode 0 (default)
1	x	0	GLCO
1	x	1	RTC output mode 1

All other values are reserved.

[Figure 7-1](#) shows the timing of GLCO and the timing of RTC.

9.2.22 Horizontal Sync (HSYNC) Start Register

Address	16h								
Default	80h								
		7	6	5	4	3	2	1	0
HSYNC start									

HSYNC start:

- 1111 1111 = - 127 × 4 pixel clocks
- 1111 1110 = - 126 × 4 pixel clocks
- 1000 0001 = - 1 × 4 pixel clocks
- 1000 0000 = 0 pixel clocks (default)
- 0111 1111 = 1 × 4 pixel clocks
- 0111 1110 = 2 × 4 pixel clocks
- 0000 0000 = 128 × 4 pixel clocks

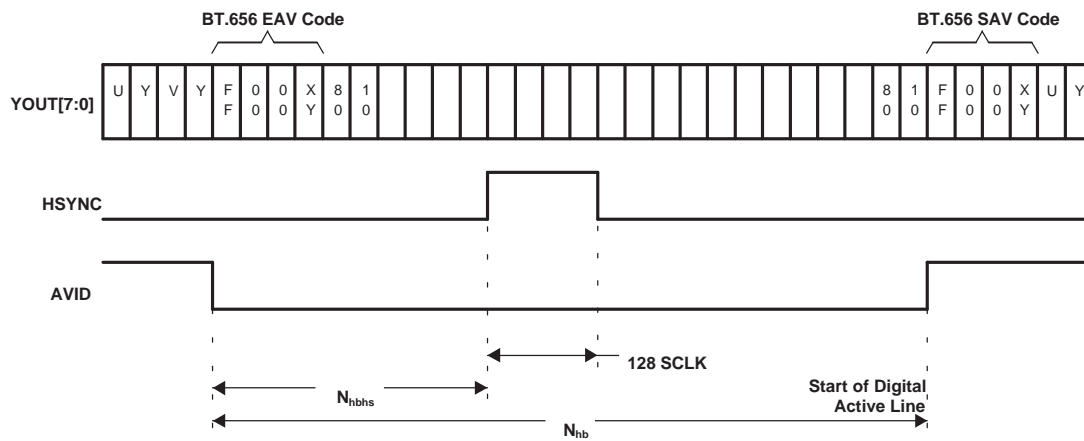

Figure 9-2. Horizontal Sync

Table 9-7. Clock Delays (CLKs)

STANDARD	N_{hbhs}	N_{hb}
NTSC	16	272
PAL	20	284
SECAM	40	280

Detailed timing information is also available in [Section 4.12, Synchronization Signals](#).

9.2.23 Ancillary SAV/EAV Control

Address	17h
Default	52h

7	6	5	4	3	2	1	0
Reserved	Scaler PD	Include scale ancillary	Include scale SAV	Include scale EAV	Include unscale ancillary	Include unscale SAV	Include unscale EAV

Include unscaled EAV:

- 0 = AVID period does not include the EAV sync codes (default).
- 1 = AVID period includes the EAV sync codes.

Include unscaled SAV:

- 0 = AVID period does not include the SAV sync codes.
- 1 = AVID period includes the SAV sync codes (default).

Include unscaled ancillary data:

- 0 = AVID period includes the ancillary data region (default).
- 1 = AVID period does not include the ancillary data region.

Include scaled EAV:

- 0 = AVID period does not include the EAV sync codes (default).
- 1 = AVID period includes the EAV sync codes.

Include scaled SAV:

- 0 = AVID period does not include the SAV sync codes.
- 1 = AVID period includes the SAV sync codes (default).

Include scaled ancillary data:

- 0 = AVID period includes the ancillary data region (default).
- 1 = AVID period does not include the ancillary data region.

Scaler PD (scaler power down):

- 0 = Scaler active
- 1 = Scaler powered down (default)

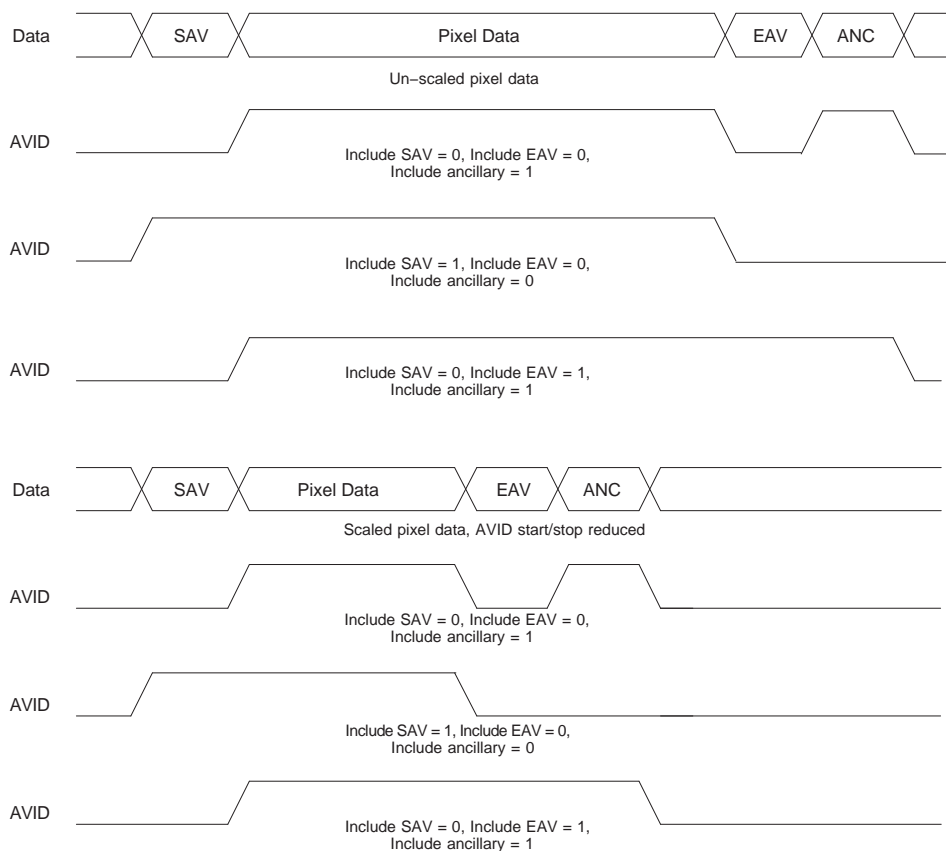

Figure 9-3. AVID Behavior When Ancillary Data Present

TVP5154
4-CHANNEL LOW-POWER PAL/NTSC/SECAM VIDEO DECODER
WITH INDEPENDENT SCALERS AND FAST LOCK

SLES163A—MARCH 2006—REVISED JULY 2006

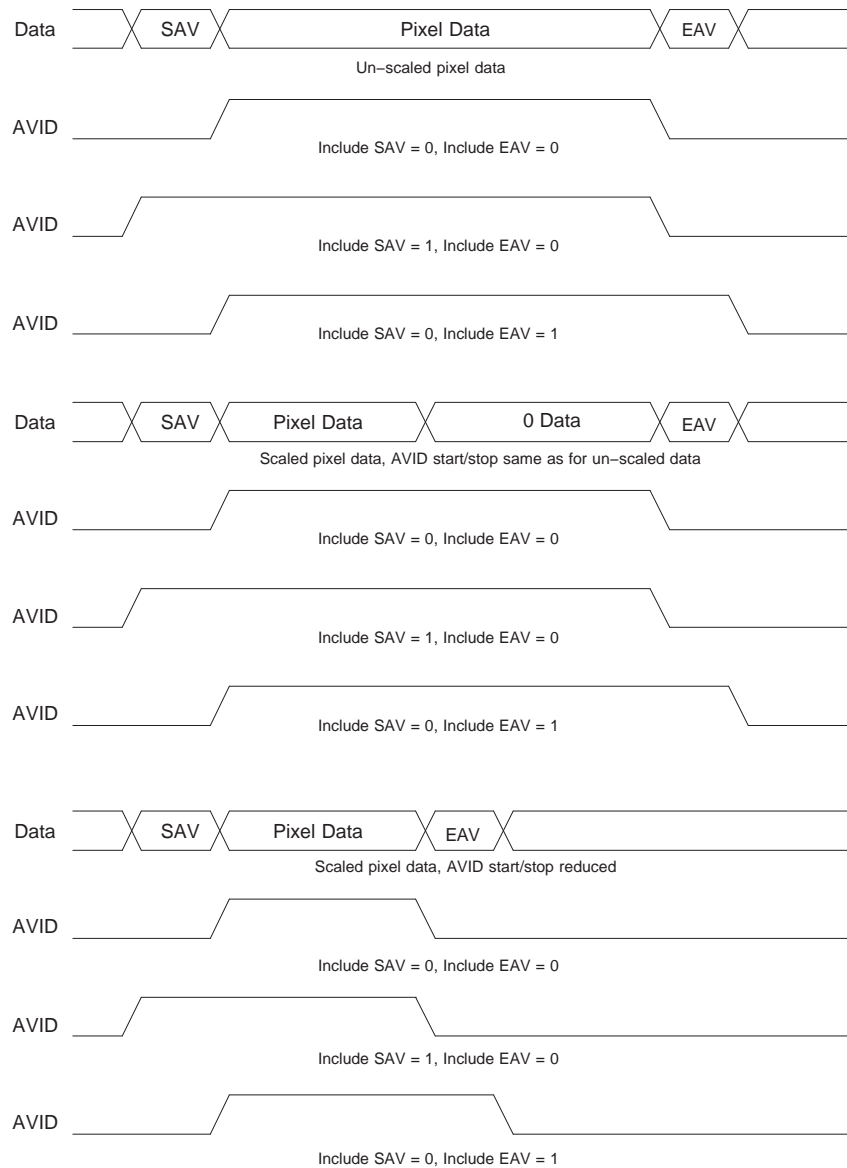

Figure 9-4. AVID Behavior When No Ancillary Data Present

9.2.24 Vertical Blanking Start Register

Address	18h						
Default	00h						
7	6	5	4	3	2	1	0
Vertical blanking start							

Vertical blanking (VBLK) start:

- 0111 1111 = 127 lines after start of vertical blanking interval
- 0000 0001 = 1 line after start of vertical blanking interval
- 0000 0000 = Same time as start of vertical blanking interval (default) (see [Figure 4-1](#), [Figure 4-2](#), and [Figure 4-3](#))
- 1111 1111 = 1 line before start of vertical blanking interval
- 1000 0000 = 128 lines before start of vertical blanking interval

Vertical blanking is adjustable with respect to the standard vertical blanking intervals. The setting in this register determines the timing of the GPCL/VBLK signal when it is configured to output vertical blank (see register 03h). The setting in this register also determines the duration of the luma bypass function (see register 07h).

9.2.25 Vertical Blanking Stop Register

Address	19h						
Default	00h						
7	6	5	4	3	2	1	0
Vertical blanking stop							

Vertical blanking (VBLK) stop:

- 0111 1111 = 127 lines after stop of vertical blanking interval
- 0000 0001 = 1 line after stop of vertical blanking interval
- 0000 0000 = Same time as stop of vertical blanking interval (default) (see [Figure 4-1](#), [Figure 4-2](#), and [Figure 4-3](#))
- 1111 1111 = 1 line before stop of vertical blanking interval
- 1000 0000 = 128 lines before stop of vertical blanking interval

Vertical blanking is adjustable with respect to the standard vertical blanking intervals. The setting in this register determines the timing of the GPCL/VBLK signal when it is configured to output vertical blank (see register 03h). The setting in this register also determines the duration of the luma bypass function (see register 07h).

9.2.26 Chrominance Control #1 Register

Address	1Ah						
Default	0Ch						
7	6	5	4	3	2	1	0
Reserved color		PLL reset	Chrominance adaptive comb filter enable (ACE)		Chrominance comb filter enable (CE)		Automatic color gain control

Color PLL reset:

- 0 = Color PLL not reset (default)
- 1 = Color PLL reset

Writing a 1 to this bit resets the color PLL and transmits a 1 in the reset bit of the GLCO output stream.

Chrominance adaptive comb filter enable (ACE):

- 0 = Disable
- 1 = Enable (default)

Chrominance comb filter enable (CE):

- 0 = Disable
- 1 = Enable (default)

Automatic color gain control (ACGC):

- 00 = ACGC enabled (default)
- 01 = Reserved
- 10 = ACGC disabled
- 11 = ACGC frozen to the previously set value

TVP5154
4-CHANNEL LOW-POWER PAL/NTSC/SECAM VIDEO DECODER
WITH INDEPENDENT SCALERS AND FAST LOCK

SLES163A–MARCH 2006–REVISED JULY 2006

9.2.27 Chrominance Control #2 Register

Address	1Bh						
Default	14h						
7	6	5	4	3	2	1	0
Reserved				Reserved	WCF	Chrominance filter select	

Wideband chroma filter (WCF):

- 0 = Disable
- 1 = Enable (default)

Chrominance filter select:

- 00 = No notch (default)
- 01 = Notch 1
- 10 = Notch 2
- 11 = Notch 3

Chrominance output bandwidth (MHz), see [Table 9-8](#)

Table 9-8. Chroma Output Bandwidth Select

WCF	FILTER SELECT	NTSC/PAL/SECAM ITU-R BT.601
0	00	1.2214
	01	0.8782
	10	0.7297
	11	0.4986
1	00	1.4170
	01	1.0303
	10	0.8438
	11	0.5537

9.2.28 Interrupt Reset Register B

Address	1Ch	
Default	00h	

7	6	5	4	3	2	1	0
Software initialization reset	Reserved	Reserved	Field rate changed reset	Line alternation changed reset	Color lock changed reset	H/V lock changed reset	TV/VCR changed reset

Interrupt reset register B is used by the external processor to reset the interrupt status bits in interrupt status register B. Bits loaded with a 1 allow the corresponding interrupt status bit to reset to 0. Bits loaded with a 0 have no effect on the interrupt status bits.

Software initialization reset:

- 0 = No effect (default)
- 1 = Reset software initialization bit

Field rate changed reset:

- 0 = No effect (default)
- 1 = Reset field rate changed bit

Line alternation changed reset:

- 0 = No effect (default)
- 1 = Reset line alternation changed bit

Color lock changed reset:

- 0 = No effect (default)
- 1 = Reset color lock changed bit

H/V lock changed reset:

- 0 = No effect (default)
- 1 = Reset H/V lock changed bit

TV/VCR changed reset [TV/VCR mode is determined by counting the total number of lines/frame. The mode switches to VCR for nonstandard number of lines]:

- 0 = No effect (default)
- 1 = Reset TV/VCR changed bit

9.2.29 Interrupt Enable Register B

Address	1Dh	
Default	00h	

7	6	5	4	3	2	1	0
Software initialization occurred enable	Reserved	Reserved	Field rate changed	Line alternation changed	Color lock changed	H/V lock changed	TV/VCR changed

TVP5154
4-CHANNEL LOW-POWER PAL/NTSC/SECAM VIDEO DECODER
WITH INDEPENDENT SCALERS AND FAST LOCK



SLES163A—MARCH 2006—REVISED JULY 2006

Software initialization occurred enable:

- 0 = Disabled (default)
- 1 = Enabled

Field rate changed:

- 0 = Disabled (default)
- 1 = Enabled

Line alternation changed:

- 0 = Disabled (default)
- 1 = Enabled

Color lock changed:

- 0 = Disabled (default)
- 1 = Enabled

H/V lock changed:

- 0 = Disabled (default)
- 1 = Enabled

TV/VCR changed:

- 0 = Disabled (default)
- 1 = Enabled

Interrupt enable register B is used by the external processor to mask unnecessary interrupt sources for interrupt B. Bits loaded with a 1 allow the corresponding interrupt condition to generate an interrupt on the external pin. Conversely, bits loaded with 0s mask the corresponding interrupt condition from generating an interrupt on the external pin. This register only affects the external pin; it does not affect the bits in the interrupt status register. A given condition can set the appropriate bit in the status register and not cause an interrupt on the external pin. To determine if this device is driving the interrupt pin, either AND interrupt status register B with interrupt enable register B, or check the state of interrupt B in the interrupt B active register.

9.2.30 Interrupt Configuration Register B

Address	1Eh						
Default	00h						

7	6	5	4	3	2	1	0
Reserved							Interrupt polarity B

Interrupt polarity B:

- 0 = Interrupt B is active low (default).
- 1 = Interrupt B is active high.

Interrupt polarity B must be same as interrupt polarity A bit at bit 0 of the interrupt configuration register A at address C2h.

Interrupt configuration register B is used to configure the polarity of interrupt B on the external interrupt pin. When the interrupt B is configured for active low, the pin is driven low when active and high impedance when inactive (open drain). Conversely, when the interrupt B is configured for active high, it is driven high for active and driven low for inactive.

9.2.31 Output Control

Address	1Fh
Default	00h

7	6	5	4	3	2	1	0
	Bit swap	Ancillary Enable	Parity modifier	SAV/EAV modifier	Output mode		

Output mode:

- 000 = Mode 0 : Unscaled data clocked by clock 1
- 001 = Mode 1 : Scaled data clocked by clock 1
- 010 = Mode 2 : Multiplexed data with separate clocks
- 011 = Mode 3 : Multiplexed data with clock 1 at 54 MHz
- 100 = Mode 4 : Unscaled/scaled field toggled data clocked by clock 1

SAV/EAV modifier:

- 0 = SAV/EAV codes not modified
- 1 = SAV/EAV MSB modified. MSB = 1 indicates unscaled data, MSB = 0 indicates scaled data

Parity modifier:

- 0 = Parity calculation includes SAV/EAV MSB.
- 1 = Parity calculation does not include SAV/EAV MSB.

Ancillary enable:

- 0 = Ancillary data not enabled
 - 1 = Ancillary data packet added to indicate scaled or unscaled data
- Note : Scaled/unscaled ancillary data cannot be enabled at the same time as VBI ancillary data

Bit swap:

- 0 = chx_out(0) corresponds to data LSB, chx_out(7) corresponds to data MSB
- 1 = chx_out(0) corresponds to data MSB, chx_out(7) corresponds to data LSB

Table 9-9. Ancillary Data Format and Sequence

BYTE NO.	D7 (MSB)	D6	D5	D4	D3	D2	D1	D0 (LSB)	DESCRIPTION	
0	0	0	0	0	0	0	0	0	Ancillary data preamble	
1	1	1	1	1	1	1	1	1		
2	1	1	1	1	1	1	1	1		
3	NEP	EP	0	1	DID3	DID2	DID1	DID0	Data ID (DID)	
4	1	0	0	0	0	0	0	0	Secondary data ID (SDID)	
5	0	1	0	0	0	0	0	1	Number of 32 bit data (NN)	
6	Video line # [7:0]								Internal data ID0 (IDID0)	
Z	0	0	0	0	0	0	Video line # [9:8]		Internal data ID1 (IDID1)	
8	00h								Data byte	Data
9	00h								Data byte	
10	1	0	00h						Check sum	
11	1	0	0	0	0	0	0	0	Fill byte	

TVP5154

4-CHANNEL LOW-POWER PAL/NTSC/SECAM VIDEO DECODER WITH INDEPENDENT SCALERS AND FAST LOCK

SLES163A–MARCH 2006–REVISED JULY 2006

- EP: Even parity for D0–D5
- NEP: Negated even parity
- DID: For unscaled data D0–D3 taken from EAV DID value for unscaled data stream register low nibble for field 0 and from high nibble for field 1
For scaled data D0–D3 taken from EAV DID value for scaled data stream register low nibble for field 0 and from high nibble for field 1
- SDID: Zero data
- NN: Indicates 1 D word of data
- IDID0: Transaction video line number [7:0]
- IDID1: Bit 0/1 = Transaction video line number [9:8]
- CS: Sum of D0–D7 of DID through last data byte
- Fill byte: Fill bytes make a multiple of four bytes from byte 0 to last fill byte. For teletext modes, byte 8 is the sync pattern byte. Byte 9 is 1. Data (the first data byte).

9.2.32 Active Video Cropping Start Pixel MSB for Scaled Data Register

Address	25h								
Default	00h								
		7	6	5	4	3	2	1	0
AVID start pixel MSB [9:2]									

Active video cropping start pixel MSB [9:2], set this register first before setting register 26h. The TVP5154 decoder updates the AVID start values only when register 26h is written to. This start pixel value is relative to the default values of the AVID start pixel.

9.2.33 Active Video Cropping Start Pixel LSB for Scaled Data Register

Address	26h								
Default	00h								
		7	6	5	4	3	2	1	0
Reserved							Active	AVID start pixel LSB [1:0]	

AVID active:

- 0 = AVID out active in VBLK (default)
- 1 = AVID out inactive in VBLK

Active video cropping start pixel LSB [1:0]: The TVP5154 decoder updates the AVID start values only when this register is written to.

AVID start [9:0]:

- 01 1111 1111 = 511
- 00 0000 0001 = 1
- 00 0000 0000 = 0 (default)
- 11 1111 1111 = –1
- 10 0000 0000 = –512

9.2.34 Video Standard Register

Address	28h						
Default	00h						
7	6	5	4	3	2	1	0
Reserved				Video standard			

Video standard:

0000 = Autoswitch mode (default)
 0001 = Reserved
 0010 = (M) NTSC ITU-R BT.601
 0011 = Reserved
 0100 = (B, G, H, I, N) PAL ITU-R BT.601
 0101 = Reserved
 0110 = (M) PAL ITU-R BT.601
 0111 = Reserved
 1000 = (Combination-N) PAL ITU-R BT.601
 1001 = Reserved
 1010 = NTSC 4.43 ITU-R BT.601
 1011 = Reserved
 1100 = SECAM ITU-R BT.601

With the autoswitch code running, the user can force the device to operate in a particular video standard mode and sample rate by writing the appropriate value into this register.

9.2.35 Active Video Cropping Stop Pixel MSB for Scaled Data Register

Address	29h						
Default	00h						
7	6	5	4	3	2	1	0
AVID stop pixel MSB [9:2]							

Active video cropping stop pixel MSB [9:2], set this register first before setting the register 2Ah. The TVP5154 decoder updates the AVID stop values only when register 2Ah is written to. This stop pixel value is relative to the default values of the AVID stop pixel.

9.2.36 Active Video Cropping Stop Pixel LSB for Scaled Data Register

Address	2Ah						
Default	00h						
7	6	5	4	3	2	1	0
Reserved					AVID stop pixel LSB [1:0]		

AVID stop [9:0]:

01 1111 1111 = 511
 00 0000 0001 = 1
 00 0000 0000 = 0 (default) (see [Figure 4-1](#), [Figure 4-2](#), and [Figure 4-3](#))
 11 1111 1111 = -1
 10 0000 0000 = -512

Active video cropping stop pixel LSB [1:0]: The number of pixels of active video must be an even number. The TVP5154 decoder updates the AVID stop values only when this register is written to.

TVP5154
4-CHANNEL LOW-POWER PAL/NTSC/SECAM VIDEO DECODER
WITH INDEPENDENT SCALERS AND FAST LOCK



SLES163A—MARCH 2006—REVISED JULY 2006

9.2.37 Cb Gain Factor Register

Address	2Ch						
7	6	5	4	3	2	1	0
Cb gain factor							

This is a read-only register that provides the gain applied to the Cb in the YCbCr data stream.

9.2.38 Cr Gain Factor Register

Address	2Dh						
7	6	5	4	3	2	1	0
Cr gain factor							

This is a read-only register that provides the gain applied to the Cr in the YCbCr data stream.

9.2.39 656 Revision Select Register

Address	30h						
Default	00h						
7	6	5	4	3	2	1	0
							656 Rev

656 revision select:

- 0 = Adheres to ITU-R BT656.4 timing
- 1 = Adheres to ITU-R BT656.3 timing

9.2.40 MSB of Device ID Register

Address	80h						
Default	51h						
7	6	5	4	3	2	1	0
MSB of device ID							

This register identifies the MSB of the device ID. Value = 0x51.

9.2.41 LSB of Device ID Register

Address	81h						
Default	54h						
7	6	5	4	3	2	1	0
LSB of device ID							

This register identifies the LSB of the device ID. Value = 0x54.

9.2.42 ROM Major Version Register

Address	82h						
Default	02h						
7	6	5	4	3	2	1	0
ROM major version ⁽¹⁾							

(1) This register can contain a number from 0x01 to 0xFF.

9.2.43 ROM Minor Version Register

Address	83h						
Default	00h						
7	6	5	4	3	2	1	0
ROM minor version ⁽¹⁾							

(1) This register can contain a number from 0x01 to 0xFF.

9.2.44 Vertical Line Count MSB Register

Address	84h						
7	6	5	4	3	2	1	0
Reserved						Vertical line count MSB	

Vertical line count bits [9:8]

9.2.45 Vertical Line Count LSB Register

Address	85h						
7	6	5	4	3	2	1	0
Vertical line count LSB							

Vertical line count bits [7:0]

Registers 84h and 85h can be read and combined to extract the detected number of lines per frame. This can be used with nonstandard video signals, such as a VCR in fast-forward or rewind modes, to synchronize the downstream video circuitry.

9.2.46 Interrupt Status Register B

Address	86h						
7	6	5	4	3	2	1	0
Software initialization	Reserved	Command ready	Field rate changed	Line alternation changed	Color lock changed	H/V lock changed	TV/VCR changed

Software initialization:

- 0 = Software initialization is not ready (default).
- 1 = Software initialization is ready.

Command ready:

- 0 = TVP5154 is not ready to accept a new command (default).
- 1 = TVP5154 is ready to accept a new command.

Field rate changed:

- 0 = Field rate has not changed (default).
- 1 = Field rate has changed.

Line alternation changed:

- 0 = Line alteration has not changed (default).
- 1 = Line alternation has changed.

Color lock changed:

- 0 = Color lock status has not changed (default).
- 1 = Color lock status has changed.

H/V lock changed:

- 0 = H/V lock status has not changed (default).
- 1 = H/V lock status has changed.

TV/VCR changed:

- 0 = TV/VCR status has not changed (default).
- 1 = TV/VCR status has changed.

Interrupt status register B is polled by the external processor to determine the interrupt source for interrupt B. After an interrupt condition is set, it can be reset by writing to the interrupt reset register B at subaddress 1Ch with a 1 in the appropriate bit.

9.2.47 Interrupt Active Register B

Address	87h						
7	6	5	4	3	2	1	0
Reserved							Interrupt B

Interrupt B:

- 0 = Interrupt B is not active on the external terminal (default).
- 1 = Interrupt B is active on the external terminal.

The interrupt active register B is polled by the external processor to determine if interrupt B is active.

9.2.48 Status Register #1

Address	88h						
7	6	5	4	3	2	1	0
Peak white detect status	Line-alternating status	Field rate status	Lost lock detect	Color subcarrier lock status	Vertical sync lock status	Horizontal sync lock status	TV/VCR status

Peak white detect status:

- 0 = Peak white is not detected.
- 1 = Peak white is detected.

Line-alternating status:

- 0 = Nonline alternating
- 1 = Line alternating

Field rate status:

- 0 = 60 Hz
- 1 = 50 Hz

Lost lock detect:

- 0 = No lost lock since status register #1 was last read
- 1 = Lost lock since status register #1 was last read

Color subcarrier lock status:

- 0 = Color subcarrier is not locked.
- 1 = Color subcarrier is locked.

Vertical sync lock status:

- 0 = Vertical sync is not locked.
- 1 = Vertical sync is locked.

Horizontal sync lock status:

- 0 = Horizontal sync is not locked.
- 1 = Horizontal sync is locked.

TV/VCR status. TV mode is determined by detecting standard line-to-line variations and specific chroma SCH phases based on the standard input video format. VCR mode is determined by detecting variations in the chroma SCH phases compared to the chroma SCH phases of the standard input video format.

- 0 = TV
- 1 = VCR

9.2.49 Status Register #2

Address	89h						
7	6	5	4	3	2	1	0
Reserved	Weak signal detection	PAL switch polarity	Field sequence status	AGC and offset frozen status	Reserved		

Weak signal detection:

- 0 = No weak signal
- 1 = Weak signal mode

PAL switch polarity of first line of odd field:

- 0 = PAL switch is 0.
- 1 = PAL switch is 1.

Field sequence status:

- 0 = Even field
- 1 = Odd field

AGC and offset frozen status:

- 0 = AGC and offset are not frozen.
- 1 = AGC and offset are frozen.

9.2.50 Status Register #3

Address	8Ah						
7	6	5	4	3	2	1	0
Front-end AGC gain value (analog and digital) ⁽¹⁾							

(1) Represents eight bits (MSB) of a 10-bit value
This register provides the front-end AGC gain value of both analog and digital gains.

9.2.51 Status Register #4

Address	8Bh						
7	6	5	4	3	2	1	0
Subcarrier to horizontal (SCH) phase							

SCH (color PLL subcarrier phase at 50% of the falling edge of horizontal sync of line one of odd field; step size 360°/256):

0000 0000 = 0.00°
 0000 0001 = 1.41°
 0000 0010 = 2.81°
 1111 1110 = 357.2°
 1111 1111 = 358.6°

9.2.52 Status Register #5

Address	8Ch						
7	6	5	4	3	2	1	0
Autoswitch mode		Reserved		Video standard		Sampling rate	

Autoswitch mode:
 0 = Stand-alone (forced video standard) mode
 1 = Autoswitch mode

This register contains information about the detected video standard and the sampling rate at which the device is currently operating. When autoswitch code is running, this register must be tested to determine which video standard has been detected.

Table 9-10. Auto Switch Video Standard

VIDEO STANDARD [3:1]			SR ⁽¹⁾	VIDEO STANDARD
BIT 3	BIT 2	BIT 1	BIT 0	
0	0	0	0	Reserved
0	0	0	1	(M) NTSC ITU-R BT.601
0	0	1	0	Reserved
0	0	1	1	(B, G, H, I, N) PAL ITU-R BT.601
0	1	0	0	Reserved
0	1	0	1	(M) PAL ITU-R BT.601
0	1	1	0	Reserved
0	1	1	1	PAL-N ITU-R BT.601
1	0	0	0	Reserved
1	0	0	1	NTSC 4.43 ITU-R BT.601
1	0	1	0	Reserved
1	0	1	1	SECAM ITU-R BT.601

(1) Sampling rate (SR): 0 = Reserved, 1 = ITU-R BT.601

9.2.53 Closed Caption Data Registers

Address	90h–93h							
Address	7	6	5	4	3	2	1	0
90h	Closed caption field 1 byte 1							
91h	Closed caption field 1 byte 2							
92h	Closed caption field 2 byte 1							
93h	Closed caption field 2 byte 2							

These registers contain the closed caption data arranged in bytes per field.

9.2.54 WSS Data Registers

Address	94h–99h							
---------	---------	--	--	--	--	--	--	--

NTSC

Address	7	6	5	4	3	2	1	0	BYTE
94h			b5	b4	b3	b2	b1	b0	WSS field 1 byte 1
95h	b13	b12	b11	b10	b9	b8	b7	b6	WSS field 1 byte 2
96h			b19	b18	b17	b16	b15	b14	WSS field 1 byte 3
97h			b5	b4	b3	b2	b1	b0	WSS field 2 byte 1
98h	b13	b12	b11	b10	b9	b8	b7	b6	WSS field 2 byte 2
99h			b19	b18	b17	b16	b15	b14	WSS field 2 byte 3

These registers contain the wide screen signaling (WSS) data for NTSC.

Bits 0–1 represent word 0, aspect ratio.

Bits 2–5 represent word 1, header code for word 2.

Bits 6–13 represent word 2, copy control.

Bits 14–19 represent word 3, CRC.

PAL/SECAM

Address	7	6	5	4	3	2	1	0	BYTE
94h	b7	b6	b5	b4	b3	b2	b1	b0	WSS field 1 byte 1
95h			b13	b12	b11	b10	b9	b8	WSS field 1 byte 2
96h	Reserved								
97h	b7	b6	b5	b4	b3	b2	b1	b0	WSS field 2 byte 1
98h			b13	b12	b11	b10	b9	b8	WSS field 2 byte 2
99h	Reserved								

Bits 0–3 represent group 1, aspect ratio.

Bits 4–7 represent group 2, enhanced services.

Bits 8–10 represent group 3, subtitles.

Bits 11–13 represent group 4, others.

9.2.55 VPS Data Registers

Address	9Ah–A6h							
Address	7	6	5	4	3	2	1	0
9Ah	VPS byte 1							
9Bh	VPS byte 2							
9Ch	VPS byte 3							
9Dh	VPS byte 4							
9Eh	VPS byte 5							
9Fh	VPS byte 6							
A0h	VPS byte 7							
A1h	VPS byte 8							
A2h	VPS byte 9							
A3h	VPS byte 10							
A4h	VPS byte 11							
A5h	VPS byte 12							
A6h	VPS byte 13							

These registers contain the entire VPS data line except the clock run-in code or the start code.

9.2.56 VITC Data Registers

Address	A7h–AFh							
Address	7	6	5	4	3	2	1	0
A7h	VITC byte 1, frame byte 1							
A8h	VITC byte 2, frame byte 2							
A9h	VITC byte 3, seconds byte 1							
AAh	VITC byte 4, seconds byte 2							
ABh	VITC byte 5, minutes byte 1							
ACh	VITC byte 6, minutes byte 2							
ADh	VITC byte 7, hour byte 1							
A Eh	VITC byte 8, hour byte 2							
AFh	VITC byte 9, CRC							

These registers contain the VITC data.

9.2.57 VBI FIFO Read Data Register

Address	B0h							
	7	6	5	4	3	2	1	0
FIFO read data								

This address is provided to access VBI data in the FIFO through the host port. All forms of teletext data come directly from the FIFO, while all other forms of VBI data can be programmed to come from the registers or from the FIFO. Current status of the FIFO can be found at address C6h and the number of bytes in the FIFO is located at address C7h. If the host port is to be used to read data from the FIFO, the output formatter must be disabled at address CDh bit 0. The format used for the VBI FIFO is shown in [Section 4.9](#).

9.2.58 Teletext Filter and Mask Registers

Address	B1h–BAh	
Default	00h	

Address	7	6	5	4	3	2	1	0
B1h		Filter 1 mask 1				Filter 1 pattern 1		
B2h		Filter 1 mask 2				Filter 1 pattern 2		
B3h		Filter 1 mask 3				Filter 1 pattern 3		
B4h		Filter 1 mask 4				Filter 1 pattern 4		
B5h		Filter 1 mask 5				Filter 1 pattern 5		
B6h		Filter 2 mask 1				Filter 2 pattern 1		
B7h		Filter 2 mask 2				Filter 2 pattern 2		
B8h		Filter 2 mask 3				Filter 2 pattern 3		
B9h		Filter 2 mask 4				Filter 2 pattern 4		
BAh		Filter 2 mask 5				Filter 2 pattern 5		

For an NABTS system, the packet prefix consists of five bytes. Each byte contains four data bits (D[3:0]) interlaced with four Hamming protection bits (H[3:0]):

Bit 7	Bit 6	Bit 5	Bit 4	Bit 3	Bit 2	Bit 1	Bit 0
D[3]	H[3]	D[2]	H[2]	D[1]	H[1]	D[0]	H[0]

Only the data portion D[3:0] from each byte is applied to a teletext filter function with the corresponding pattern bits P[3:0] and mask bits M[3:0]. Hamming protection bits are ignored by the filter.

For a WST system (PAL or NTSC), the packet prefix consists of two bytes so that two patterns are used. Patterns 3, 4, and 5 are ignored.

The mask bits enable filtering using the corresponding bit in the pattern register. For example, a 1 in the LSB of mask 1 means that the filter module must compare the LSB of nibble 1 in the pattern register to the first data bit on the transaction. If these match, a true result is returned. A 0 in a bit of mask 1 means that the filter module must ignore that data bit of the transaction. If all 0s are programmed in the mask bits, the filter matches all patterns returning a true result (default 00h).

Pattern and mask for each byte and filter are referred as <1,2><P,M><1,2,3,4,5> where:

- <1,2> identifies the filter 1 or 2
- <P,M> identifies the pattern or mask
- <1,2,3,4,5> identifies the byte number

9.2.59 Teletext Filter Control Register

Address	BBh	
Default	00h	

7	6	5	4	3	2	1	0
Reserved		Filter logic		Mode	TTX filter 2 enable		TTX filter 1 enable

Filter logic: Allows different logic to be applied when combining the decision of filter 1 and filter 2 as follows:

- 00 = NOR (default)
- 01 = NAND
- 10 = OR
- 11 = AND

Mode:

- 0 = Teletext WST PAL mode B (2 header bytes) (default)
- 1 = Teletext NABTS NTSC mode C (5 header bytes)

TTX filter 2 enable:

- 0 = Disabled (default)
- 1 = Enabled

TTX filter 1 enable:

- 0 = Disabled (default)
- 1 = Enabled

If the filter matches or if the filter mask is all 0s, a true result is returned.

9.2.60 Interrupt Status Register A

Address	C0h	
Default	00h	

7	6	5	4	3	2	1	0
Lock state interrupt	Lock interrupt	Reserved		FIFO threshold interrupt	Line interrupt	Data interrupt	

Lock state interrupt:

- 0 = TVP5154 is not locked to the video signal (default)
- 1 = TVP5154 is locked to the video signal.

Lock interrupt:

- 0 = A transition has not occurred on the lock signal (default).
- 1 = A transition has occurred on the lock signal.

FIFO threshold interrupt:

- 0 = The amount of data in the FIFO has not yet crossed the threshold programmed at address C8h (default).
- 1 = The amount of data in the FIFO has crossed the threshold programmed at address C8h.

Line interrupt:

- 0 = The video line number has not yet been reached (default).
- 1 = The video line number programmed in address CAh has occurred.

Data interrupt:

- 0 = No data is available (default).
- 1 = VBI data is available either in the FIFO or in the VBI data registers.

The interrupt status register A can be polled by the host processor to determine the source of an interrupt. After an interrupt condition is set it can be reset by writing to this register with a 1 in the appropriate bit(s).

9.2.61 Interrupt Enable Register A

Address	C1h	
Default	00h	

7	6	5	4	3	2	1	0
Reserved	Lock interrupt enable	Cycle complete interrupt enable	Bus error interrupt enable	Reserved	FIFO threshold interrupt enable	Line interrupt enable	Data interrupt enable

Lock interrupt enable:

0 = Disabled (default)

1 = Enabled

Cycle complete interrupt enable:

0 = Disabled (default)

1 = Enabled

Bus error interrupt enable:

0 = Disabled (default)

1 = Enabled

FIFO threshold interrupt enable:

0 = Disabled (default)

1 = Enabled

Line interrupt enable:

0 = Disabled (default)

1 = Enabled

Data interrupt enable:

0 = Disabled (default)

1 = Enabled

The interrupt enable register A is used by the host processor to mask unnecessary interrupt sources. Bits loaded with a 1 allow the corresponding interrupt condition to generate an interrupt on the external pin. Conversely, bits loaded with a 0 mask the corresponding interrupt condition from generating an interrupt on the external pin. This register only affects the interrupt on the external terminal, it does not affect the bits in interrupt status register A. A given condition can set the appropriate bit in the status register and not cause an interrupt on the external terminal. To determine if this device is driving the interrupt terminal either perform a logical AND of interrupt status register A with interrupt enable register A, or check the state of the interrupt A bit in the interrupt configuration register at address C2h.

9.2.62 Interrupt Configuration Register A

Address	C2h	
Default	04h	

7	6	5	4	3	2	1	0
Reserved					YCbCr enable (VDPOE)	Interrupt A	Interrupt polarity A

YCbCr enable (VDPOE):

- 0 = YCbCr pins are high impedance.
- 1 = YCbCr pins are active if other conditions are met (default).

Interrupt A (read only):

- 0 = Interrupt A is not active on the external pin (default).
- 1 = Interrupt A is active on the external pin.

Interrupt polarity A:

- 0 = Interrupt A is active low (default).
- 1 = Interrupt A is active high.

Interrupt configuration register A is used to configure the polarity of the external interrupt terminal. When interrupt A is configured as active low, the terminal is driven low when active and high impedance when inactive (open collector). Conversely, when the terminal is configured as active high, it is driven high when active and driven low when inactive.

9.2.63 VDP Configuration RAM Register

Address	C3h	C4h	C5h	
Default	B8h	1Fh	00h	

Address	7	6	5	4	3	2	1	0	
C3h	Configuration data								
C4h	RAM address (7:0)								
C5h	Reserved							RAM address 8	

The configuration RAM data is provided to initialize the VDP with initial constants. The configuration RAM is 512 bytes organized as 32 different configurations of 16 bytes each. The first 12 configurations are defined for the current VBI standards. An additional two configurations can be used as a custom programmed mode for unique standards, such as Gemstar.

Address C3h is used to read or write to the RAM. The RAM internal address counter is automatically incremented with each transaction. Addresses C5h and C4h make up a 9-bit address to load the internal address counter with a specific start address. This can be used to write a subset of the RAM for only those standards of interest. Registers D0h–FBh must all be programmed with FFh before writing or reading the configuration RAM. Full field mode (CFh) must be disabled as well.

The suggested RAM contents are shown in the following table. All values are hexadecimal.

TVP5154
4-CHANNEL LOW-POWER PAL/NTSC/SECAM VIDEO DECODER
WITH INDEPENDENT SCALERS AND FAST LOCK

SLES163A—MARCH 2006—REVISED JULY 2006

Index	Address	0	1	2	3	4	5	6	7	8	9	A	B	C	D	E	F
Reserved	000	Reserved															
WST SECAM	010	AA	AA	FF	FF	E7	2E	20	26	E6	B4	0E	0	0	0	10	0
Reserved	020	Reserved															
WST PAL B	030	AA	AA	FF	FF	27	2E	20	2B	A6	72	10	0	0	0	10	0
Reserved	040	Reserved															
WST PAL C	050	AA	AA	FF	FF	E7	2E	20	22	A6	98	0D	0	0	0	10	0
Reserved	060	Reserved															
WST NTSC	070	AA	AA	FF	FF	27	2E	20	23	69	93	0D	0	0	0	10	0
Reserved	080	Reserved															
NABTS, NTSC	090	AA	AA	FF	FF	E7	2E	20	22	69	93	0D	0	0	0	15	0
Reserved	0A0	Reserved															
NABTS, NTSC-J	0B0	AA	AA	FF	FF	A7	2E	20	23	69	93	0D	0	0	0	10	0
Reserved	0C0	Reserved															
CC, PAL/SECAM	0D0	AA	2A	FF	3F	04	51	6E	02	A6	7B	09	0	0	0	27	0
Reserved	0E0	Reserved															
CC, NTSC	0F0	AA	2A	FF	3F	04	51	6E	02	69	8C	09	0	0	0	27	0
Reserved	100	Reserved															
WSS, PAL/SECAM	110	5B	55	C5	FF	0	71	6E	42	A6	CD	0F	0	0	0	3A	0
Reserved	120	Reserved															
WSS, NTSC C	130	38	00	3F	00	0	71	6E	43	69	7C	08	0	0	0	39	0
Reserved	140	Reserved															
VITC, PAL/SECAM	150	0	0	0	0	0	8F	6D	49	A6	85	08	0	0	0	4C	0
Reserved	160	Reserved															
VITC, NTSC	170	0	0	0	0	0	8F	6D	49	69	94	08	0	0	0	4C	0
Reserved	180	Reserved															
VPS, PAL	190	AA	AA	FF	FF	BA	CE	2B	0D	A6	DA	0B	0	0	0	60	0
Reserved	1A0	Reserved															
Custom 1	1B0	Programmable															
Reserved	1C0	Reserved															
Custom 2	1D0	Programmable															

9.2.64 VDP Status Register

Address	C6h						
7	6	5	4	3	2	1	0
FIFO full error	FIFO empty	TTX available	CC field 1 available	CC field 2 available	WSS available	VPS available	VITC available

The VDP status register indicates whether data is available in either the FIFO or data registers, and status information about the FIFO. Reading data from the corresponding register does not clear the status flags automatically. These flags are only reset by writing a 1 to the respective bit. However, bit 6 is updated automatically.

FIFO full error:

- 0 = No FIFO full error
- 1 = FIFO was full during a write to FIFO.

The FIFO full error flag is set when the current line of VBI data can not enter the FIFO. For example, if the FIFO has only ten bytes left and teletext is the current VBI line, the FIFO full error flag is set, but no data is written because the entire teletext line will not fit. However, if the next VBI line is closed caption requiring only two bytes of data plus the header, this goes into the FIFO (even if the full error flag is set).

FIFO empty:

- 0 = FIFO is not empty.
- 1 = FIFO is empty.

TTX available:

- 0 = Teletext data is not available.
- 1 = Teletext data is available.

CC field 1 available:

- 0 = Closed caption data from field 1 is not available.
- 1 = Closed caption data from field 1 is available.

CC field 2 available:

- 0 = Closed caption data from field 2 is not available.
- 1 = Closed caption data from field 2 is available.

WSS available:

- 0 = WSS data is not available.
- 1 = WSS data is available.

VPS available

- 0 = VPS data is not available.
- 1 = VPS data is available.

VITC available:

- 0 = VITC data is not available.
- 1 = VITC data is available.

9.2.65 FIFO Word Count Register

Address	C7h						
7	6	5	4	3	2	1	0
Number of words							

This register provides the number of words in the FIFO. One word equals two bytes.

9.2.66 FIFO Interrupt Threshold Register

Address	C8h						
Default	80h						
7	6	5	4	3	2	1	0
Number of words							

This register is programmed to trigger an interrupt when the number of words in the FIFO exceeds this value (default 80h). This interrupt must be enabled at address C1h. One word equals two bytes.

9.2.67 FIFO Reset Register

Address	C9h						
Default	00h						
7	6	5	4	3	2	1	0
Any data							

Writing any data to this register resets the FIFO and clears any data present in both the FIFO and the VDP registers.

9.2.68 Line Number Interrupt Register

Address	CAh						
Default	00h						
7	6	5	4	3	2	1	0
Field 1 enable	Field 2 enable	Line number					

This register is programmed to trigger an interrupt when the video line number matches this value in bits 5:0. This interrupt must be enabled at address C1h. The value of 0 or 1 does not generate an interrupt.

Field 1 enable:

0 = Disabled (default)

1 = Enabled

Field 2 enable:

0 = Disabled (default)

1 = Enabled

Line number: (default 00h)

9.2.69 Pixel Alignment Registers

Address	CBh	CCh						
Default	4Eh	00h						
Address	7	6	5	4	3	2	1	0
CBh	Switch pixel [7:0]							
CCh	Reserved					Switch pixel [9:8]		

These registers form a 10-bit horizontal pixel position from the falling edge of sync, where the VDP controller initiates the program from one line standard to the next line standard; for example, the previous line of teletext to the next line of closed caption. This value must be set so that the switch occurs after the previous transaction has cleared the delay in the VDP, but early enough to allow the new values to be programmed before the current settings are required.

9.2.70 FIFO Output Control Register

Address	CDh						
Default	01h						
7	6	5	4	3	2	1	0
Reserved						Host access enable	

This register is programmed to allow I²C access to the FIFO or allowing all VDP data to go out the video port.

Host access enable:

0 = Output FIFO data to the video output Y[7:0]

1 = Allow I²C access to the FIFO data (default)

9.2.71 Full Field Enable Register

Address	CFh						
Default	00h						
7	6	5	4	3	2	1	0
Reserved							Full field enable

This register enables the full field mode. In this mode, all lines outside the vertical blank area and all lines in the line mode registers programmed with FFh are sliced with the definition of register FCh. Values other than FFh in the line mode registers allow a different slice mode for that particular line.

Full field enable:

- 0 = Disable full field mode (default)
- 1 = Enable full field mode

9.2.72 Line Mode Registers

Address	D0h	D1h–FBh	
Default	00h	FFh	

TVP5154
4-CHANNEL LOW-POWER PAL/NTSC/SECAM VIDEO DECODER
WITH INDEPENDENT SCALERS AND FAST LOCK

SLES163A—MARCH 2006—REVISED JULY 2006

Address	7	6	5	4	3	2	1	0
D0h								Line 6 Field 1
D1h								Line 6 Field 2
D2h								Line 7 Field 1
D3h								Line 7 Field 2
D4h								Line 8 Field 1
D5h								Line 8 Field 2
D6h								Line 9 Field 1
D7h								Line 9 Field 2
D8h								Line 10 Field 1
D9h								Line 10 Field 2
DAh								Line 11 Field 1
DBh								Line 11 Field 2
DCh								Line 12 Field 1
DDh								Line 12 Field 2
DEh								Line 13 Field 1
DFh								Line 13 Field 2
E0h								Line 14 Field 1
E1h								Line 14 Field 2
E2h								Line 15 Field 1
E3h								Line 15 Field 2
E4h								Line 16 Field 1
E5h								Line 16 Field 2
E6h								Line 17 Field 1
E7h								Line 17 Field 2
E8h								Line 18 Field 1
E9h								Line 18 Field 2
EAh								Line 19 Field 1
EBh								Line 19 Field 2
ECh								Line 20 Field 1
EDh								Line 20 Field 2
EEh								Line 21 Field 1
EFh								Line 21 Field 2
F0h								Line 22 Field 1
F1h								Line 22 Field 2
F2h								Line 23 Field 1
F3h								Line 23 Field 2
F4h								Line 24 Field 1
F5h								Line 24 Field 2
F6h								Line 25 Field 1
F7h								Line 25 Field 2
F8h								Line 26 Field 1
F9h								Line 26 Field 2
FAh								Line 27 Field 1
FBh								Line 27 Field 2

These registers program the specific VBI standard at a specific line in the video field.

Bit 7:

- 0 = Disable filtering of null bytes in closed caption modes.
- 1 = Enable filtering of null bytes in closed caption modes (default).

In teletext modes, bit 7 enables the data filter function for that particular line. If it is set to 0, the data filter passes all data on that line.

Bit 6:

- 0 = Send VBI data to registers only.
- 1 = Send VBI data to FIFO and the registers. Teletext data only goes to FIFO. (default)

Bit 5:

- 0 = Allow VBI data with errors in the FIFO.
- 1 = Do not allow VBI data with errors in the FIFO (default).

Bit 4:

- 0 = Do not enable error detection and correction.
- 1 = Enable error detection and correction (when bits [3:0] = 1 2, 3, and 4 only) (default).

Bits [3:0]:

- 0000 = WST SECAM
- 0001 = WST PAL B
- 0010 = WST PAL C
- 0011 = WST NTSC
- 0100 = NABTS NTSC C
- 0101 = NABTS NTSC D
- 0110 = CC PAL
- 0111 = CC NTSC
- 1000 = WSS PAL
- 1001 = WSS NTSC
- 1010 = VITC PAL
- 1011 = VITC NTSC
- 1100 = VPS PAL
- 1101 = Custom 1
- 1110 = Custom 2
- 1111 = Active video (VDP off) (default)

A value of FFh in the line mode registers is required for any line to be sliced as part of the full field mode.

9.2.73 Full Field Mode Register

Address	FCh							
Default	7Fh							
7	6	5	4	3	2	1	0	
Full field mode								

This register programs the specific VBI standard for full field mode. It can be any VBI standard. Individual line settings take priority over the full field register. This allows each VBI line to be programmed independently but have the remaining lines in full field mode. The full field mode register has the same definitions as the line mode registers (default 7Fh).

9.2.74 Decoder Write Enable

Address	FEh							
Default	0Fh							
7	6	5	4	3	2	1	0	
Reserved				Decoder 4	Decoder 3	Decoder 2	Decoder 1	

This register controls which of the four decoder cores receives I²C write transactions. A 1 in the corresponding bit position enables the decoder to receive write commands.

Any combination of decoders can be configured to receive write commands, allowing all four decoders to be programmed concurrently.

9.2.75 Decoder Read Enable

Address	FFh							
Default	00h							
7	6	5	4	3	2	1	0	
Reserved				Decoder 4	Decoder 3	Decoder 2	Decoder 1	

This register controls which of the four decoder cores responds to I²C read transactions. A 1 in the corresponding bit position enables the decoder to respond to read commands.

If more than one decoder is enabled for reading, only the lowest numbered decoder responds. Reads from multiple decoders at the same time is not possible.

Note that when register 0xFE is written to with any value, register 0xFF is set to 0x00. Likewise, when register 0xFF is written to with any value, register 0xFE is set to 0x00.

9.3 Indirect Register Definitions

To write to the TVP5154 indirect registers, it is required that the registers be unlocked using a password. The password prevents undesirable writes into the device at start-up due to power surges, for example.

The following example demonstrates the method for unlocking the indirect registers.

After writing to the desired indirect registers described in the following text, it is recommended that the device be locked again.

- Unlock the device
 1. Write 0x51 to I2C_0x21. //MSB data
 2. Write 0x54 to I2C_0x22. //LSB data
 3. Write 0xFF to I2C_0x23. //Data address
 4. Write 0x04 to I2C_0x24. //Write command

- Lock the device
 1. Write 0x00 to I2C_0x21. //MSB data
 2. Write 0x00 to I2C_0x22. //LSB data
 3. Write 0xFF to I2C_0x23. //Data address
 4. Write 0x04 to I2C_0x24. //Write command

Indirect registers are written to by performing the following I²C transaction:

```

START : DEVICE_ID_w : 0x21 : DATA_HIGH : STOP
START : DEVICE_ID_w : 0x22 : DATA_LOW : STOP
START : DEVICE_ID_w : 0x23 : ADDRESS_LOW : STOP
START : DEVICE_ID_w : 0x24 : WR_STROBE : STOP
  
```

To read from an indirect register, the following I²C transaction should be performed:

```

START : DEVICE_ID_w : 0x23 : ADDRESS_LOW : STOP
START : DEVICE_ID_w : 0x24 : RD_STROBE : STOP
START : DEVICE_ID_r : 0x21 : data_msb : STOP
START : DEVICE_ID_r : 0x22 : data_lsb : STOP
  
```

Where:

DEVICE_ID_w is the selected TVP5154 device ID with the read/write bit (LSB) set to write.

DEVICE_ID_r is the selected TVP5154 device ID with the read/write bit (LSB) set to read.

ADDRESS_LOW is the low byte of the register address.

WR_STROBE is 0x06.

RD_STROBE is 0x05.

Note, the upper byte of the address is not directly used but is replaced by the corresponding STROBE signal.

Each indirect register is 16 bits wide.

9.3.1 DID Control

Address	36Ah	
Default	000h	

7	6	5	4	3	2	1	0
Unscaled field 1 DID				Unscaled field 0 DID			
15	14	13	12	11	10	9	8
Scaled field 1 DID				Scaled field 0 DID			

This register controls the value of the EAV DID bytes for scaled and unscaled data. The value for each field can be independently set, allowing identification of both which field is being processed and whether the data comes from the scaled or unscaled channel.

9.3.2 Misc Control

Address	36Bh						
Default	0Ch						
7	6	5	4	3	2	1	0
Clock rate			Clock OE			Clock edge	
15	14	13	12	11	10	9	8
Scaled blank data							

Scaled blank data:

When no active scaled data is available, this value is output during the active video region.

Clock rate:

This register controls various clock modes. Since this register is modified by the device during normal operation, the clock rate bits should not be modified by the user.

Clock OE:

This register controls various clock modes. Since this register is modified by the device during normal operation, the clock rate bits should not be modified by the user.

Clock edge:

This register controls various clock modes. Since this register is modified by the device during normal operation, the clock rate bits should not be modified by the user.

9.3.3 Interleave Field Control 1

Address	36Dh						
Default	0h						
7	6	5	4	3	2	1	0
End pixel count[7:0]							
15	14	13	12	11	10	9	8
Field count				Reserved	Blank timing	End pixel count[9:8]	

End pixel count:

Pixel count at which the frame status is updated. Do not change this value.

Blank timing:

0: No timing signals are generated for blank fields.

1: H, V, and F timing generated for blank fields based on unscaled video timing sequences

Field count:

Number of output fields in field interleaved sequence

9.3.4 Interleave Field Control 2

Address	36Eh						
Default	0h						
7	6	5	4	3	2	1	0
Field mode(3)		Field mode(2)		Field mode(1)		Field mode(0)	
15	14	13	12	11	10	9	8
Field mode(7)		Field mode(6)		Field mode(5)		Field mode(4)	

9.3.5 Interleave Field Control 3

Address	36Fh						
Default	0h						
7	6	5	4	3	2	1	0
Field mode(11)		Field mode(10)		Field mode(9)		Field mode(8)	
15	14	13	12	11	10	9	8
Field mode(15)		Field mode(14)		Field mode(13)		Field mode(12)	

These registers allow the output data stream to toggle between unscaled and scaled data on a field basis. By setting Field mode[n] appropriately, it is possible to use the available output bandwidth to interleave unscaled and scaled frames to achieve reduced frame rates, while still maintaining compatibility with legacy data receivers. These registers can also be used to reduce the frame rate of either unscaled data or scaled data by disabling fields within the sequence.

A counter automatically moves from Field mode[0] to Field mode[n] where n can be 0 through 15, then returns back to Field mode[0]. Depending on the value of Field mode[n], either unscaled data, scaled data, or no data is sent for the current frame.

- 00 = Unscaled data
- 01 = Null frame (no SAV/EAV sequence will be generated)
- 10 = Scaled data
- 11 = Reserved

The values programmed for registers 3A8h and 3A9h are different for NTSC (also NTSC4.43 and PAL-M) and for PAL (also PAL-Nc and SECAM).

9.3.6 Vertical Scaling Field 1 Control

Address	3A8h						
Default	0h						
7	6	5	4	3	2	1	0
V_Field1[7:0]							
15	14	13	12	11	10	9	8
Reserved							V_Field1[8]

Vertical scaling initial value in field 1 [8:0]: Initial value of vertical accumulator for field 1

For NTSC:

$$V_Field1 = (1.5 \times V_Field2) - 128$$

If V_Field 1 is negative, add V_Field2 to V_Field1 and add V_Field2 to V_Field2 until V_Field1 is positive.

For PAL:

$$V_Field1 = (V_{desired}/V_{active}) \times 256$$

9.3.7 Vertical Scaling Field 2 Control

Address	3A9h						
Default	0h						
7	6	5	4	3	2	1	0
V_Field2[7:0]							
15	14	13	12	11	10	9	8
Reserved							V_Field2[8]

Vertical scaling initial value in field 2 [8:0]: Initial value of vertical accumulator for field 2

For NTSC:

$$V_Field2 = (V_{desired}/V_{active}) \times 256$$

For PAL:

$$V_Field2 = (1.5 \times V_Field1) - 128$$

If V_Field 2 is negative, add V_Field1 to V_Field2 and add V_Field1 to V_Field1 until V_Field2 is positive.

9.3.8 Scaler Output Active Pixels

Address	3ABh						
Default	2D0h						
7	6	5	4	3	2	1	0
SCAL_PIXEL[7:0]							
15	14	13	12	11	10	9	8
Reserved							SCAL_PIXEL[9:8]

SCAL_PIXEL [9:0]: Scaler active pixel outputs per line

9.3.9 Vertical Scaling Control

Address	3ACh						
Default	2100h						
7	6	5	4	3	2	1	0
VERT_COEF[7:0]							
15	14	13	12	11	10	9	8
Reserved		1	Enable	Reserved			VERT_COEF[8]

Enabled: Enable vertical and horizontal scaler

0 = Disable scaler (default)

1 = Enable scaler

VERT_COEF [8:0]: Vertical scaling coefficient

$VERT_COEF = (V_{desired}/V_{active}) \times 256$

9.3.10 Horizontal Scaling Control

Address	3ADh						
Default	400h						
7	6	5	4	3	2	1	0
HORZ_COEF[7:0]							
15	14	13	12	11	10	9	8
Reserved	HORZ_COEF[14:8]						

HORZ_COEF[14:0]: Horizontal scaling coefficient, MSB five bits are integer values and LSB ten bits are fraction numbers.

$HORZ_COEF = H_{active}/H_{desired}$

10 Scaler Configuration

10.1 Overview

The TVP5154 contains four independent scalers, one for each video decoder channel. Each scaler is able to filter and scale both horizontally and vertically to different ratios.

Horizontally, a 7-tap poly-phase filter is used to ensure optimal scaling performance, and can be configured to scale to any output size below the input resolution, in decrements of two pixels. Vertically a running average filter is used to filter vertically and can be configured to scale to any output size below the input resolution.

When scaling horizontally, the output pixels are packed together to allow continuous reading of the pixels. AVID should be configured so that it qualifies the active pixels, allowing the receiving back end to ignore nonactive pixels. When scaling vertically, inactive lines are not removed from the output since there is no internal frame memory. The receiving back end must use AVID to qualify active lines/pixels. AVID can be configured to be either active or inactive during invalid output lines.

Due to the fact that vertical scaling is performed on a field basis, it is possible that the vertical resolution will be reduced due to filtering across lines within the field, rather than adjacent lines in the frame. Aliasing will not occur, but the output image will appear soft vertically. If the desired scaling ration is 0.5, this can be achieved by simply ignoring every other field. This maintains sharpness, but may introduce aliasing artifacts.

10.2 Horizontal Scaling

10.2.1 Registers

The horizontal scaler uses a 32-phase polymorphic filter. Excellent performance can be achieved by using the set of coefficients programmed into the 5154 for all scaling ratios.

It is necessary to program the input and output scaling control registers (3AB and 3AD).

Figure 10-1 shows how data is packed horizontally when scaled.

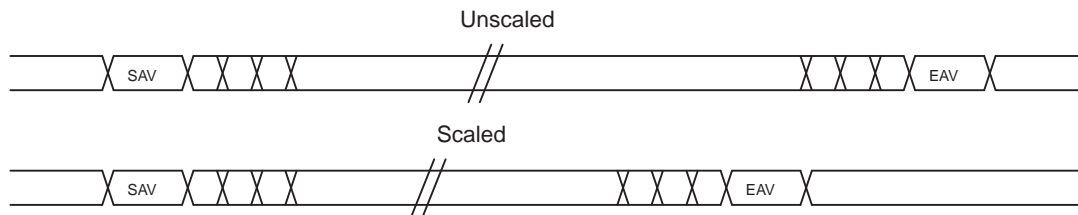

Figure 10-1. Unscaled and Scaled Pixel Data Alignment

10.3 Vertical Scaling

10.3.1 Registers

The vertical scaler implements a weighted running average filter, which requires the initial weights and the ratio registers to be configured.

Additionally, it is necessary to program the input and output scaling control registers (3A8, 3A9, and 3AC).

Figure 10-2 shows the active and inactive data lines when scaled vertically.

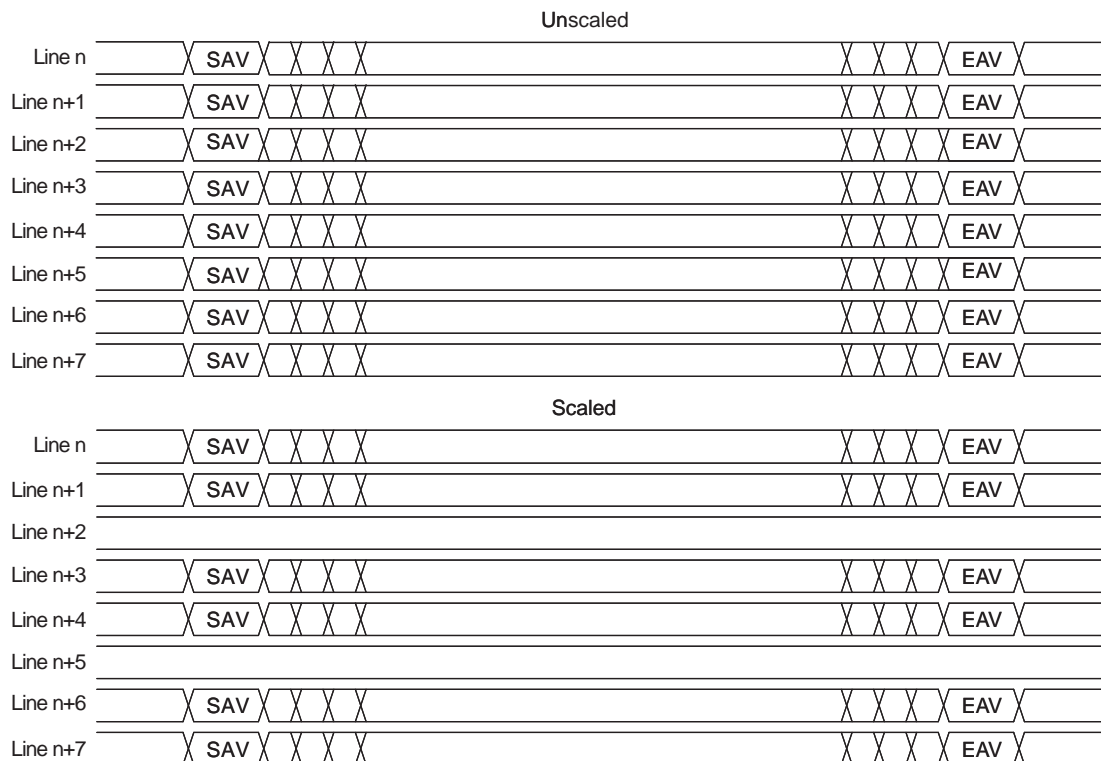

Figure 10-2. Unscaled and Scaled Vertical Data Formatting

10.4 Field Interleaving

In systems where either there are insufficient video ports on the back end processor to accommodate both scaled and unscaled video streams, or where the back end processor does not have sufficient processing power to perform compression on the unscaled image at the same time as other video processing, such as compositing of scaled images for display, it is possible to configure the TVP5154 to output different image types on consecutive fields. In this configuration, the field rates for each of the scaled and unscaled images is reduced to accommodate the interleaving of fields, while maintaining a 27-MHz pixel clock.

This is useful in video recording systems that are required to display a scaled image but still wish to compress and store full resolution images, albeit at reduced field rates.

Field interleaving can generate a sequence of up to 16 fields, where each field can be either unscaled, scaled, or blank.

10.4.1 Registers

The field loop count register controls how many fields are in the sequence. The field mode registers control the output field type for each field.

Figure 10-3 shows how to configure field interleaving for a sequence of five fields where the first field is unscaled, the second field is scaled, the third field is blank, the fourth field is scaled, and the fifth field is blank.

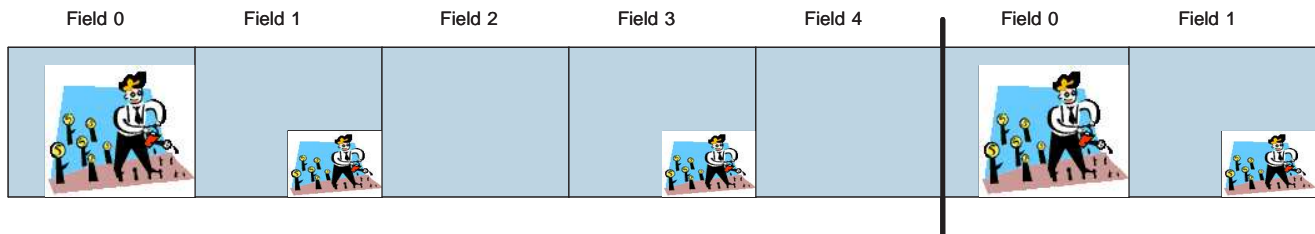

Figure 10-3. Field Interleaving

Various additional registers exist to configure how the TVP5154 indicates to the back-end processor the state of the current field. The Output Control register 1Fh allows the scaled/unscaled status to be indicated by the upper bit of the SAV/EAV codes. The Output Control register 1Fh also allows the scaled/unscaled status to be indicated by the DID codes of ancillary data.

11 Electrical Specifications

11.1 Absolute Maximum Ratings⁽¹⁾

over operating free-air temperature range (unless otherwise noted)

		VALUE	UNIT
Supply voltage range	IOVDD to DGND	–0.5 to 3.6	V
	DVDD to DGND	– 0.5 to 2	
	PLL_AVDD to PLL_AGND	–0.5 to 2	
	AVDD to AGND	–0.5 to 2	
Digital input voltage range, V_I to DGND		–0.5 to 3.6	V
Input voltage range, XIN to PLL_GND		–0.5 to 2	V
Analog input voltage range, A_I to AGND		–0.2 to 2	V
Digital output voltage range, V_O to DGND		–0.5 to 3.6	V
T_A	Operating free-air temperature range	0 to 70	°C
T_{stg}	Storage temperature range	–65 to 150	°C

- (1) Stresses beyond those listed under *absolute maximum ratings* may cause permanent damage to the device. These are stress ratings only and functional operation of the device at these or any other conditions beyond those indicated under *recommended operating conditions* is not implied. Exposure to absolute-maximum-rated conditions for extended periods may affect device reliability.

11.2 Recommended Operating Conditions

		MIN	NOM	MAX	UNIT
IOVDD	Digital I/O supply voltage	3.0	3.3	3.6	V
DVDD	Digital supply voltage	1.65	1.8	1.95	V
PLL_AVDD	Analog PLL supply voltage	1.65	1.8	1.95	V
AVDD	Analog core supply voltage	1.65	1.8	1.95	V
$V_{I(P-P)}$	Analog input voltage (ac-coupling necessary)	0		0.75	V
V_{IH}	Digital input voltage high	0.7 IOVDD			V
V_{IL}	Digital input voltage low			0.3 IOVDD	V
V_{IH_XIN}	XIN input voltage high	0.7 PLL_AVDD			V
V_{IL_XIN}	XIN input voltage low			0.3 PLL_AVDD	V
I_{OH}	High-level output current	2	4		mA
I_{OL}	Low-level output current	–2	–4		mA
I_{OH_CLK}	CLK high-level output current	4	8		mA
I_{OL_CLK}	CLK low-level output current	–4	–8		mA
T_A	Operating free-air temperature	0		70	°C

11.3 Crystal Specifications

	TYP	UNIT
Frequency	14.31818	MHz
Frequency tolerance	±50	ppm

11.4 Electrical Characteristics

For typical values: Nominal conditions, $T_A = 25^\circ\text{C}$

For minimum/maximum values: Over recommended operating conditions (unless otherwise noted)

PARAMETER	TEST CONDITIONS ⁽¹⁾	MIN	TYP	MAX	UNIT
DC					
$I_{DD(IO_D)}$	I/O digital supply current at 27 MHz		46	52	mA
	I/O digital supply current at 54 MHz		84	90	mA
$I_{DD(D)}$	Digital supply current		154	174	mA
$I_{DD(PLL_A)}$	Analog PLL supply current		20	29	mA
$I_{DD(A)}$	Analog core supply current		134	168	mA
P_{TOT}	Total power dissipation, normal mode at 27 MHz		706	910	mW
	Total power dissipation, normal mode at 54 MHz		832	1050	mW
C_i	Input capacitance ⁽³⁾			10	pF
V_{OH}	Output voltage high	$I_{OH} = 2\text{ mA}$	0.8 IOVDD		V
V_{OL}	Output voltage low	$I_{OL} = -2\text{ mA}$		0.22 IOVDD	V
V_{OH_CLK}	CLK output voltage high	$I_{OH} = 4\text{ mA}$	0.8 IOVDD		V
V_{OL_CLK}	CLK output voltage low	$I_{OL} = -4\text{ mA}$		0.22 IOVDD	V
I_{IH}	High-level input current	$V_I = V_{IH}$		± 22	μA
I_{IL}	Low-level input current	$V_I = V_{IL}$		± 22	μA
Analog Processing and ADCs (at FS = 30 MSPS)					
Z_i	Input impedance, analog video inputs	By design	200	500	k Ω
C_i	Input capacitance, analog video inputs	By design		10	pF
$V_{I(pp)}$	Input voltage range ⁽⁴⁾	$C_{coupling} = 0.1\ \mu\text{F}$	0	0.75	V
DG	Gain control minimum		0		dB
DG	Gain control maximum		12		dB
DNL	DC differential nonlinearity	A/D only	± 0.5	± 1	LSB
INL	DC integral nonlinearity	A/D only	± 1	± 2.5	LSB
Fr	Frequency response	6 MHz	-0.9	-3	dB
SNR	Signal-to-noise ratio	1 MHz, 0.5 V_{P-P}	48	50	dB
NS	Noise spectrum ⁽³⁾	50% flat field	48	50	dB
DP	Differential phase ⁽³⁾	Modulated ramp		1.5	deg
DG	Differential gain ⁽³⁾	Modulated ramp		0.5	%

(1) Measured with a load of 15 pF.

(2) For typical measurements only

(3) By design, not production tested

(4) The 0.75-V maximum applies to the sync-chroma amplitude, not sync-white. The recommended termination resistors are 37.4 Ω .

11.5 Timing Requirements

PARAMETER	TEST CONDITIONS ⁽¹⁾	MIN	TYP	MAX	UNIT
Duty cycle SCL			50		%
t ₁	CLK high time (at 27 MHz)	13.5			ns
t ₂	CLK low time (at 27 MHz)	13.5			ns
t ₃	CLK fall time (at 27 MHz)	90% to 10%		5	ns
t ₄	CLK rise time (at 27 MHz)	10% to 90%		5	ns
t ₅	Output hold time	10			ns
t ₆	Output delay time			25	ns
t ₇	Output hold time	4			ns
t ₈	Output delay time			16.5	ns
t ₉	Data period		18.5		ns
t ₁₀	Output hold time	4			ns
t ₁₁	Output delay time			16.5	ns
t ₁₂	Data period		18.5		ns
t ₁₃	CLK high time (at 54 MHz)	3			ns
t ₁₄	CLK low time (at 54 MHz)	3			ns
t ₁₅	CLK fall time (at 54 MHz)	90% to 10%		6	ns
t ₁₆	CLK rise time (at 54 MHz)	10% to 90%		6	ns

(1) Measured with a load of 15 pF for 27-MHz signals, 25 pF for 54-MHz signals. By design. Timing not production tested.

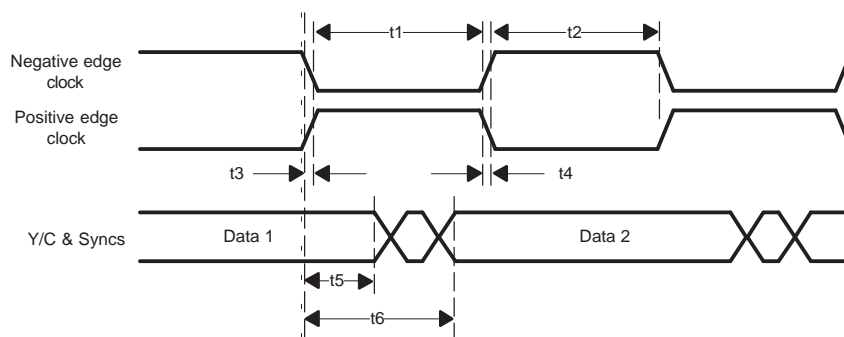

Figure 11-1. Output Modes 0 and 1: Clocks, Video Data, and Sync

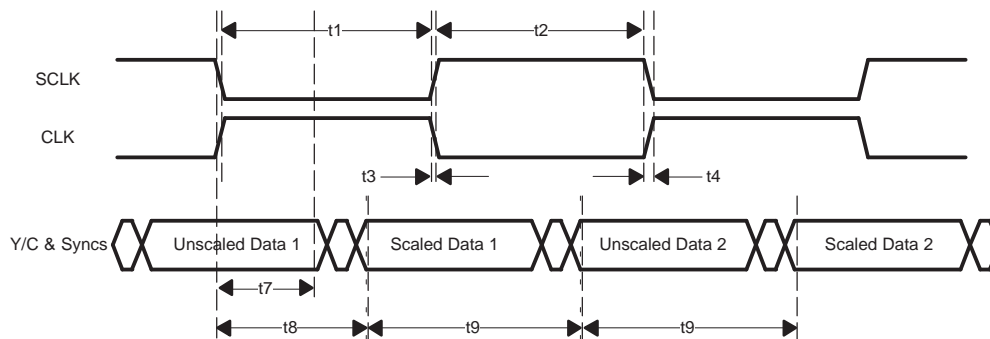

Figure 11-2. Output Mode 2: Clocks, Video Data, and Sync

TVP5154
4-CHANNEL LOW-POWER PAL/NTSC/SECAM VIDEO DECODER
WITH INDEPENDENT SCALERS AND FAST LOCK

SLES163A—MARCH 2006—REVISED JULY 2006

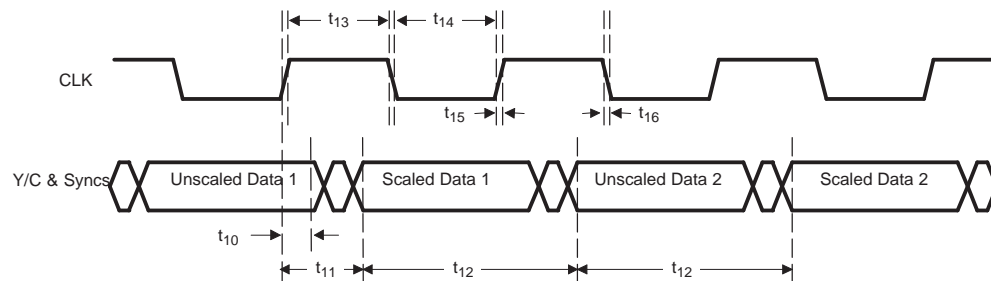

Figure 11-3. Output Mode 3: Clock, Video Data, and Sync (Positive Edge Clock)

11.6 I²C Host Port Timing

PARAMETER		TEST CONDITIONS	MIN	MAX	UNIT
t ₁	Bus free time, between STOP and START		1.3		μs
t ₂	Setup time, (repeated) START condition		0.6		μs
t ₃	Hold time, (repeated) START condition		0.6		μs
t ₄	Setup time, STOP condition		0.6		ns
t ₅	Data setup time		100		ns
t ₆	Data hold time		0	0.9	μs
t ₇	Rise time, VC1(SDA) and VC0(SCL) signal	Specified by design		250	ns
t ₈	Fall time, VC1(SDA) and VC0(SCL) signal	Specified by design		250	ns
C _b	Capacitive load for each bus line	Specified by design		400	pF
f _{I²C}	I ² C clock frequency			400	kHz

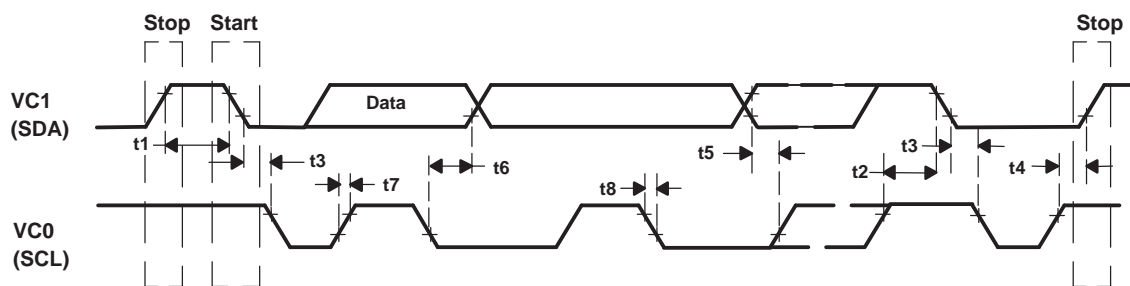
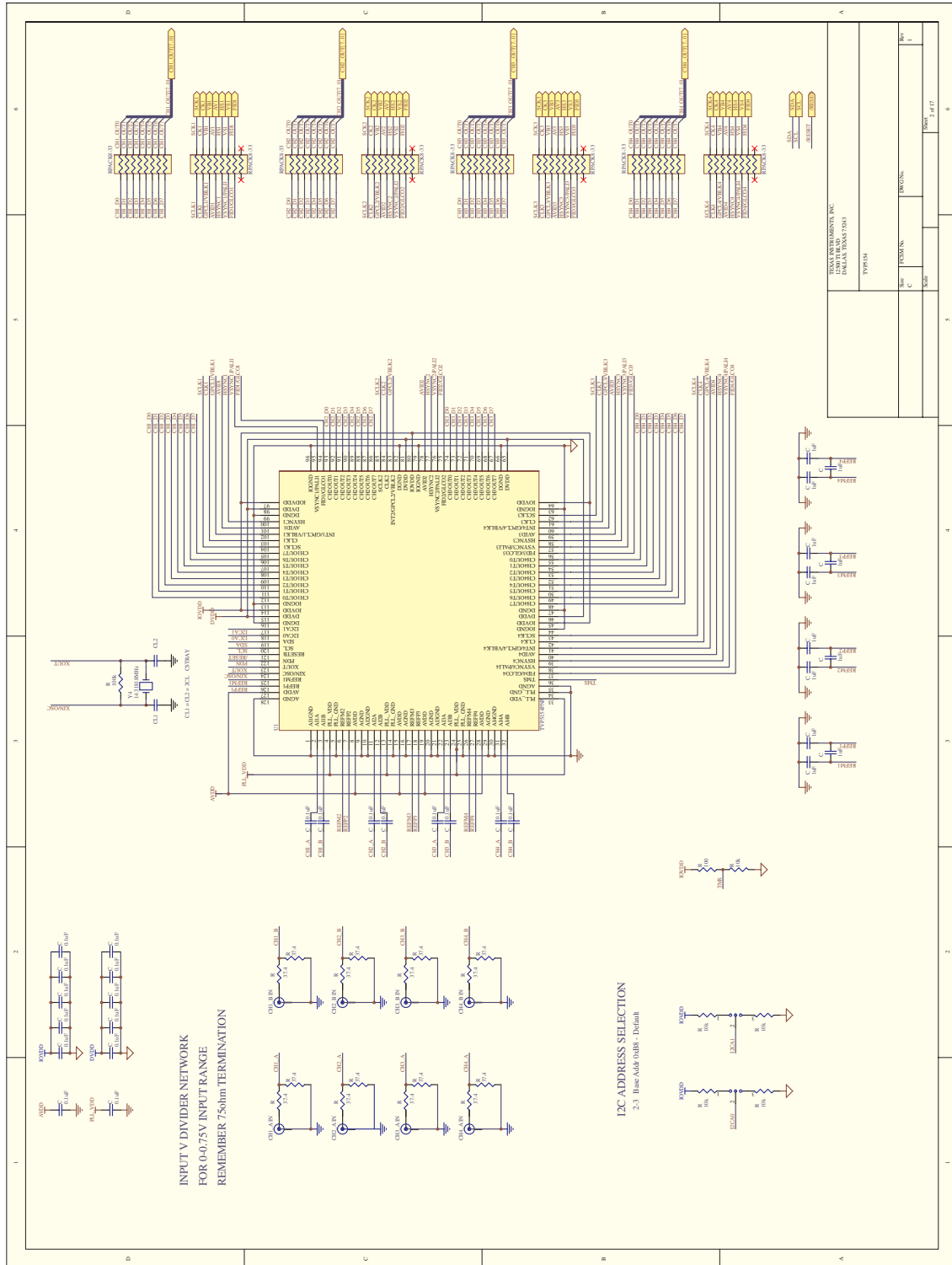

Figure 11-4. I²C Host Port Timing

TVP5154 4-CHANNEL LOW-POWER PAL/NTSC/SECAM VIDEO DECODER WITH INDEPENDENT SCALERS AND FAST LOCK

SLES163A—MARCH 2006—REVISED JULY 2006

12 Schematic



13 MECHANICAL

THERMAL INFORMATION

This PowerPAD™ package incorporates an exposed thermal pad that is designed to be attached directly to an external heatsink. When the thermal pad is soldered directly to the printed circuit board (PCB), the PCB can be used as a heatsink. In addition, through the use of thermal vias, the thermal pad can be attached directly to a ground plane or special heatsink structure designed into the PCB. This design optimizes the heat transfer from the integrated circuit (IC).

For additional information on the PowerPAD package and how to take advantage of its heat dissipating abilities, refer to Technical Brief, PowerPAD Thermally Enhanced Package, Texas Instruments Literature No. SLMA002 and Application Brief, PowerPAD Made Easy, Texas Instruments Literature No. SLMA004. Both documents are available at www.ti.com.

The exposed thermal pad dimensions for this package are shown in the following illustration.

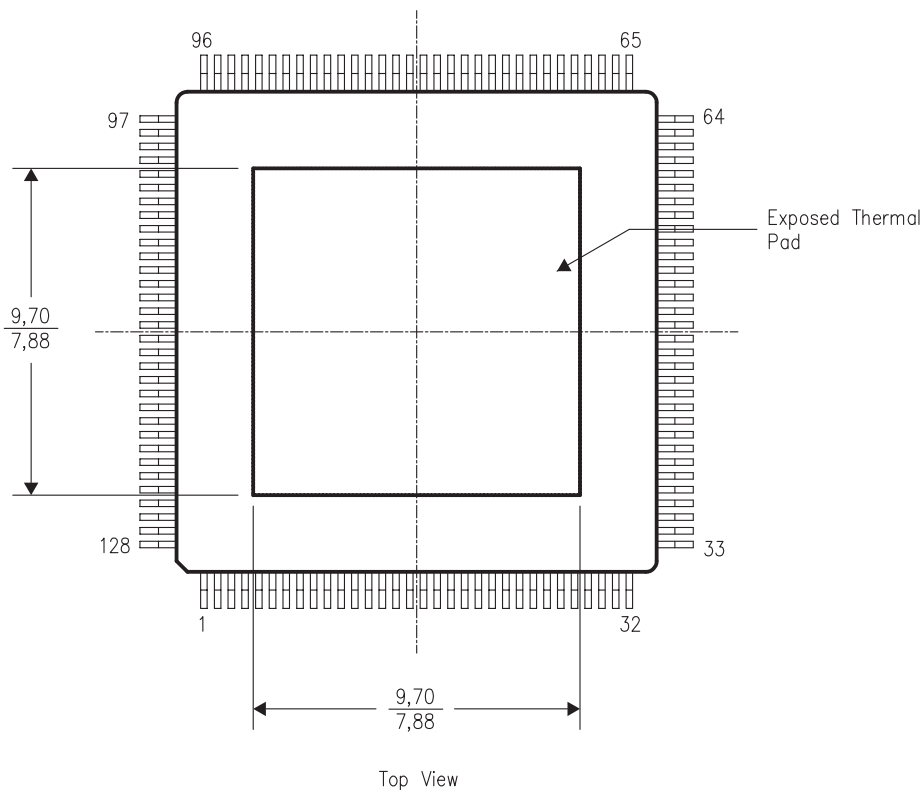

NOTE: All linear dimensions are in millimeters

Exposed Thermal Pad Dimensions

TVP5154
4-CHANNEL LOW-POWER PAL/NTSC/SECAM VIDEO DECODER
WITH INDEPENDENT SCALERS AND FAST LOCK

SLES163A—MARCH 2006—REVISED JULY 2006

PNP (S-PQFP-G128)

PowerPAD™ PLASTIC QUAD FLATPACK

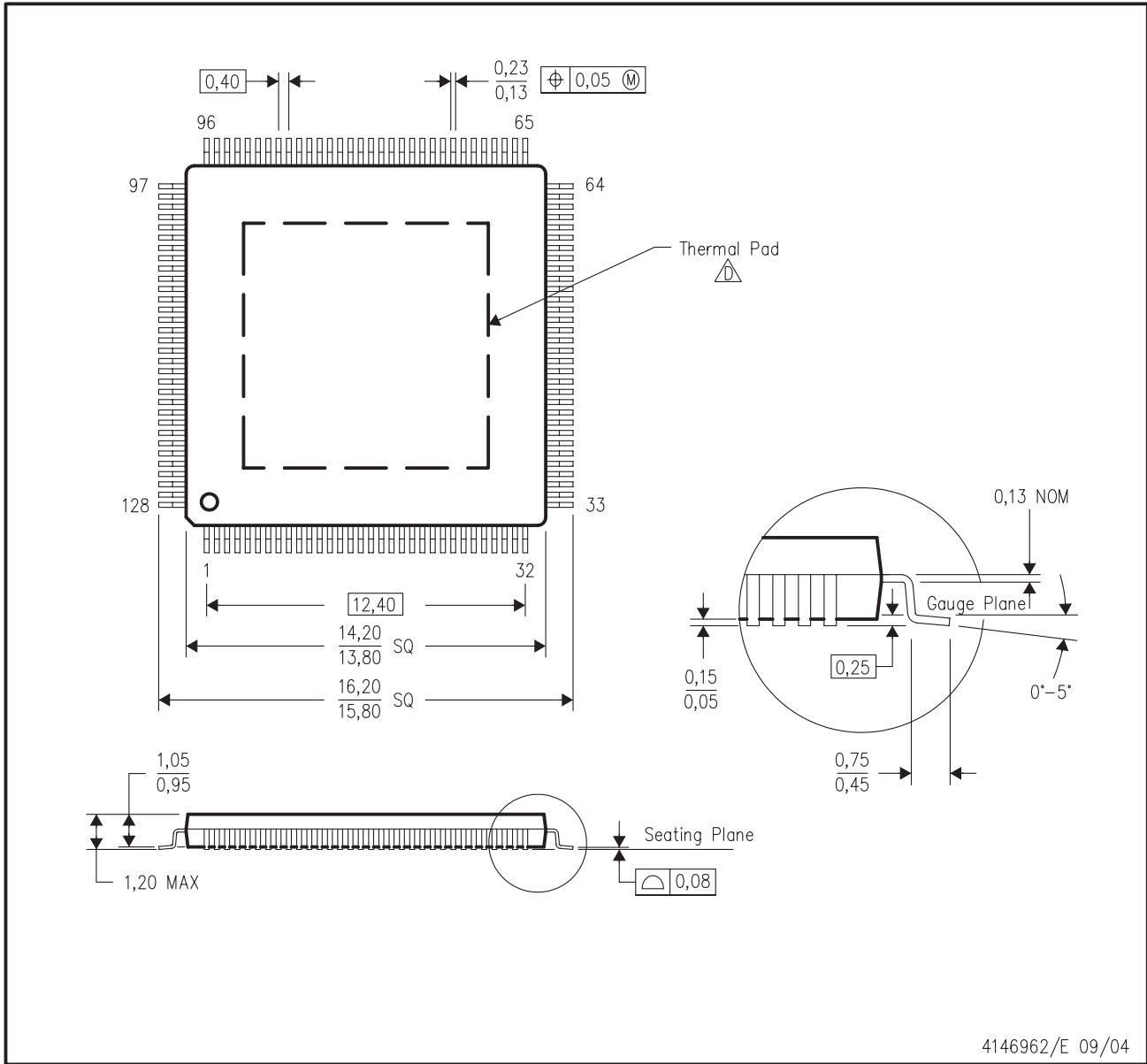

- NOTES:
- A. All linear dimensions are in millimeters.
 - B. This drawing is subject to change without notice.
 - C. Body dimensions do not include mold flash or protrusion.
 -  This package is designed to be soldered to a thermal pad on the board. Refer to Technical Brief, PowerPad Thermally Enhanced Package, Texas Instruments Literature No. SLMA002 for information regarding recommended board layout. This document is available at www.ti.com <<http://www.ti.com>>. See the product data sheet for details regarding the exposed thermal pad dimensions.

PowerPAD is a trademark of Texas Instruments.

PACKAGING INFORMATION

Orderable Device	Status (1)	Package Type	Package Drawing	Pins	Package Qty	Eco Plan (2)	Lead/Ball Finish (6)	MSL Peak Temp (3)	Op Temp (°C)	Device Marking (4/5)	Samples
TVP5154PNP	NRND	HTQFP	PNP	128	90	Green (RoHS & no Sb/Br)	CU NIPDAU	Level-3-260C-168 HR	0 to 70	TVP5154	

(1) The marketing status values are defined as follows:

ACTIVE: Product device recommended for new designs.

LIFEBUY: TI has announced that the device will be discontinued, and a lifetime-buy period is in effect.

NRND: Not recommended for new designs. Device is in production to support existing customers, but TI does not recommend using this part in a new design.

PREVIEW: Device has been announced but is not in production. Samples may or may not be available.

OBSOLETE: TI has discontinued the production of the device.

(2) **RoHS:** TI defines "RoHS" to mean semiconductor products that are compliant with the current EU RoHS requirements for all 10 RoHS substances, including the requirement that RoHS substance do not exceed 0.1% by weight in homogeneous materials. Where designed to be soldered at high temperatures, "RoHS" products are suitable for use in specified lead-free processes. TI may reference these types of products as "Pb-Free".

RoHS Exempt: TI defines "RoHS Exempt" to mean products that contain lead but are compliant with EU RoHS pursuant to a specific EU RoHS exemption.

Green: TI defines "Green" to mean the content of Chlorine (Cl) and Bromine (Br) based flame retardants meet JS709B low halogen requirements of <=1000ppm threshold. Antimony trioxide based flame retardants must also meet the <=1000ppm threshold requirement.

(3) MSL, Peak Temp. - The Moisture Sensitivity Level rating according to the JEDEC industry standard classifications, and peak solder temperature.

(4) There may be additional marking, which relates to the logo, the lot trace code information, or the environmental category on the device.

(5) Multiple Device Markings will be inside parentheses. Only one Device Marking contained in parentheses and separated by a "~" will appear on a device. If a line is indented then it is a continuation of the previous line and the two combined represent the entire Device Marking for that device.

(6) Lead/Ball Finish - Orderable Devices may have multiple material finish options. Finish options are separated by a vertical ruled line. Lead/Ball Finish values may wrap to two lines if the finish value exceeds the maximum column width.

Important Information and Disclaimer:The information provided on this page represents TI's knowledge and belief as of the date that it is provided. TI bases its knowledge and belief on information provided by third parties, and makes no representation or warranty as to the accuracy of such information. Efforts are underway to better integrate information from third parties. TI has taken and continues to take reasonable steps to provide representative and accurate information but may not have conducted destructive testing or chemical analysis on incoming materials and chemicals. TI and TI suppliers consider certain information to be proprietary, and thus CAS numbers and other limited information may not be available for release.

In no event shall TI's liability arising out of such information exceed the total purchase price of the TI part(s) at issue in this document sold by TI to Customer on an annual basis.

MECHANICAL DATA

PNP (S-PQFP-G128)

PowerPAD™ PLASTIC QUAD FLATPACK

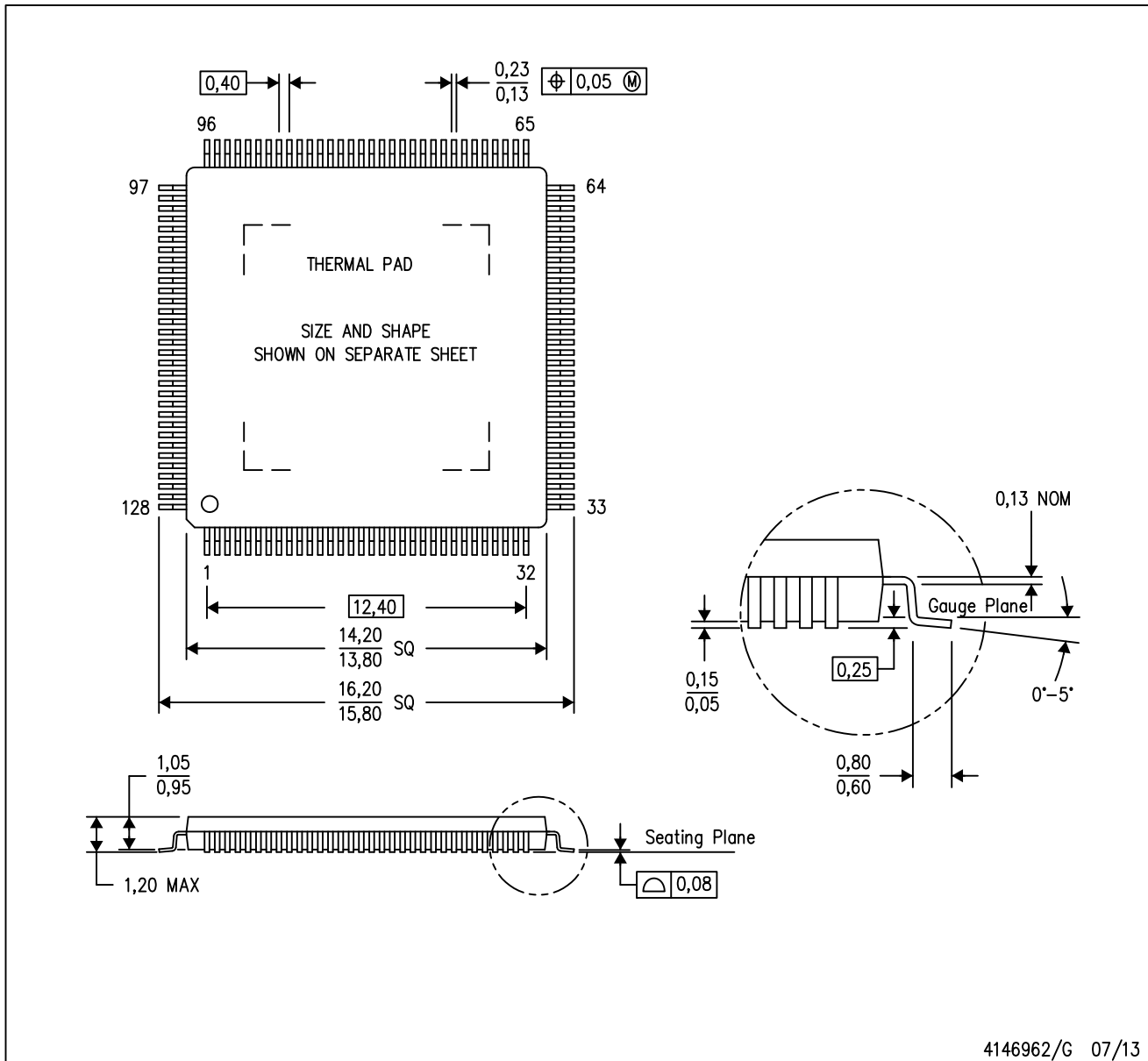

- NOTES:
- All linear dimensions are in millimeters.
 - This drawing is subject to change without notice.
 - Body dimensions do not include mold flash or protrusion
 - This package is designed to be soldered to a thermal pad on the board. Refer to Technical Brief, PowerPad Thermally Enhanced Package, Texas Instruments Literature No. SLMA002 for information regarding recommended board layout. This document is available at www.ti.com <<http://www.ti.com>>.
 - See the additional figure in the Product Data Sheet for details regarding the exposed thermal pad features and dimensions.

PowerPAD is a trademark of Texas Instruments.

THERMAL PAD MECHANICAL DATA

PNP (S-PQFP-G128)

PowerPAD™ PLASTIC QUAD FLATPACK

THERMAL INFORMATION

This PowerPAD™ package incorporates an exposed thermal pad that is designed to be attached to a printed circuit board (PCB). The thermal pad must be soldered directly to the PCB. After soldering, the PCB can be used as a heatsink. In addition, through the use of thermal vias, the thermal pad can be attached directly to the appropriate copper plane shown in the electrical schematic for the device, or alternatively, can be attached to a special heatsink structure designed into the PCB. This design optimizes the heat transfer from the integrated circuit (IC).

For additional information on the PowerPAD package and how to take advantage of its heat dissipating abilities, refer to Technical Brief, PowerPAD Thermally Enhanced Package, Texas Instruments Literature No. SLMA002 and Application Brief, PowerPAD Made Easy, Texas Instruments Literature No. SLMA004. Both documents are available at www.ti.com.

The exposed thermal pad dimensions for this package are shown in the following illustration.

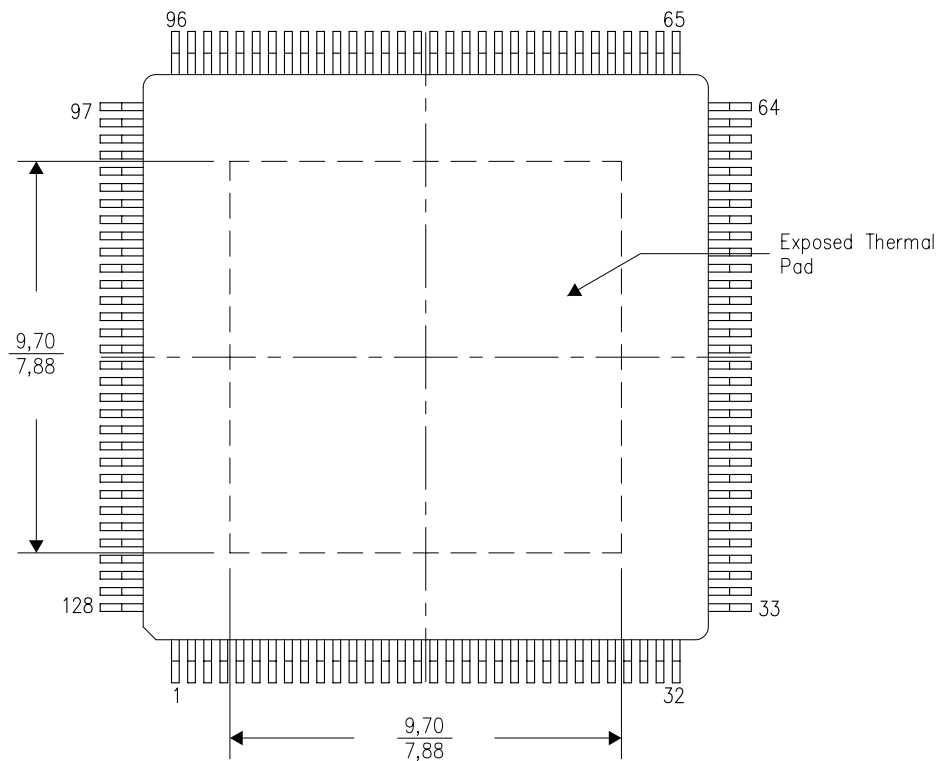

Exposed Thermal Pad Dimensions

4206232-3/L 10/11

NOTE: All linear dimensions are in millimeters

PowerPAD is a trademark of Texas Instruments

PNP (S-PQFP-G128)

PowerPAD™ PLASTIC QUAD FLAT PACK

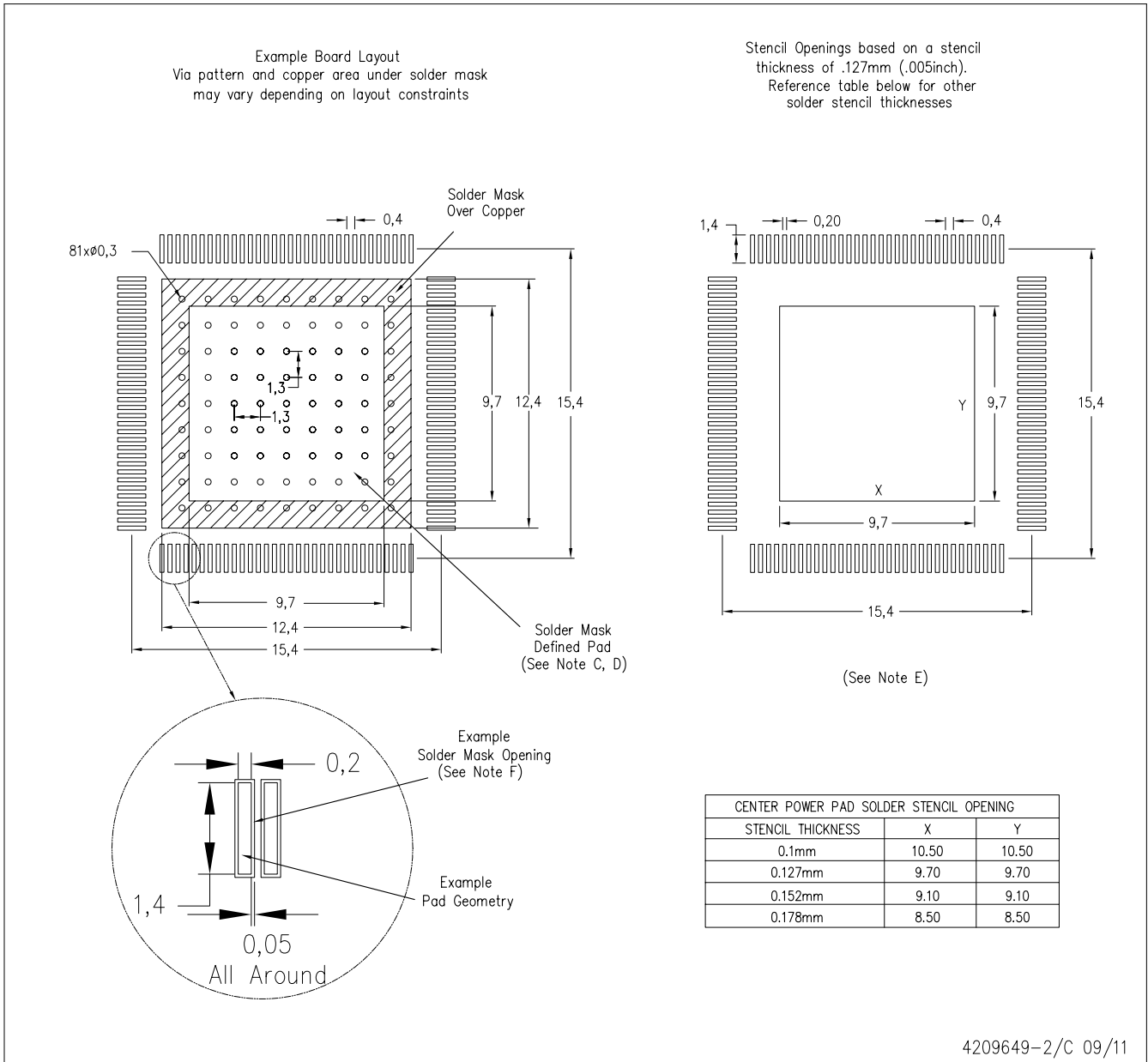

- NOTES:
- All linear dimensions are in millimeters.
 - This drawing is subject to change without notice.
 - Customers should place a note on the circuit board fabrication drawing not to alter the center solder mask defined pad.
 - This package is designed to be soldered to a thermal pad on the board. Refer to Technical Brief, PowerPad Thermally Enhanced Package, Texas Instruments Literature No. SLMA002, SLMA004, and also the Product Data Sheets for specific thermal information, via requirements, and recommended board layout. These documents are available at www.ti.com <<http://www.ti.com>>. Publication IPC-7351 is recommended for alternate designs.
 - Laser cutting apertures with trapezoidal walls and also rounding corners will offer better paste release. Customers should contact their board assembly site for stencil design recommendations. Example stencil design based on a 50% volumetric metal load solder paste. Refer to IPC-7525 for other stencil recommendations.
 - Customers should contact their board fabrication site for solder mask tolerances between and around signal pads.

PowerPAD is a trademark of Texas Instruments.

IMPORTANT NOTICE

Texas Instruments Incorporated (TI) reserves the right to make corrections, enhancements, improvements and other changes to its semiconductor products and services per JESD46, latest issue, and to discontinue any product or service per JESD48, latest issue. Buyers should obtain the latest relevant information before placing orders and should verify that such information is current and complete.

TI's published terms of sale for semiconductor products (<http://www.ti.com/sc/docs/stdterms.htm>) apply to the sale of packaged integrated circuit products that TI has qualified and released to market. Additional terms may apply to the use or sale of other types of TI products and services.

Reproduction of significant portions of TI information in TI data sheets is permissible only if reproduction is without alteration and is accompanied by all associated warranties, conditions, limitations, and notices. TI is not responsible or liable for such reproduced documentation. Information of third parties may be subject to additional restrictions. Resale of TI products or services with statements different from or beyond the parameters stated by TI for that product or service voids all express and any implied warranties for the associated TI product or service and is an unfair and deceptive business practice. TI is not responsible or liable for any such statements.

Buyers and others who are developing systems that incorporate TI products (collectively, "Designers") understand and agree that Designers remain responsible for using their independent analysis, evaluation and judgment in designing their applications and that Designers have full and exclusive responsibility to assure the safety of Designers' applications and compliance of their applications (and of all TI products used in or for Designers' applications) with all applicable regulations, laws and other applicable requirements. Designer represents that, with respect to their applications, Designer has all the necessary expertise to create and implement safeguards that (1) anticipate dangerous consequences of failures, (2) monitor failures and their consequences, and (3) lessen the likelihood of failures that might cause harm and take appropriate actions. Designer agrees that prior to using or distributing any applications that include TI products, Designer will thoroughly test such applications and the functionality of such TI products as used in such applications.

TI's provision of technical, application or other design advice, quality characterization, reliability data or other services or information, including, but not limited to, reference designs and materials relating to evaluation modules, (collectively, "TI Resources") are intended to assist designers who are developing applications that incorporate TI products; by downloading, accessing or using TI Resources in any way, Designer (individually or, if Designer is acting on behalf of a company, Designer's company) agrees to use any particular TI Resource solely for this purpose and subject to the terms of this Notice.

TI's provision of TI Resources does not expand or otherwise alter TI's applicable published warranties or warranty disclaimers for TI products, and no additional obligations or liabilities arise from TI providing such TI Resources. TI reserves the right to make corrections, enhancements, improvements and other changes to its TI Resources. TI has not conducted any testing other than that specifically described in the published documentation for a particular TI Resource.

Designer is authorized to use, copy and modify any individual TI Resource only in connection with the development of applications that include the TI product(s) identified in such TI Resource. NO OTHER LICENSE, EXPRESS OR IMPLIED, BY ESTOPPEL OR OTHERWISE TO ANY OTHER TI INTELLECTUAL PROPERTY RIGHT, AND NO LICENSE TO ANY TECHNOLOGY OR INTELLECTUAL PROPERTY RIGHT OF TI OR ANY THIRD PARTY IS GRANTED HEREIN, including but not limited to any patent right, copyright, mask work right, or other intellectual property right relating to any combination, machine, or process in which TI products or services are used. Information regarding or referencing third-party products or services does not constitute a license to use such products or services, or a warranty or endorsement thereof. Use of TI Resources may require a license from a third party under the patents or other intellectual property of the third party, or a license from TI under the patents or other intellectual property of TI.

TI RESOURCES ARE PROVIDED "AS IS" AND WITH ALL FAULTS. TI DISCLAIMS ALL OTHER WARRANTIES OR REPRESENTATIONS, EXPRESS OR IMPLIED, REGARDING RESOURCES OR USE THEREOF, INCLUDING BUT NOT LIMITED TO ACCURACY OR COMPLETENESS, TITLE, ANY EPIDEMIC FAILURE WARRANTY AND ANY IMPLIED WARRANTIES OF MERCHANTABILITY, FITNESS FOR A PARTICULAR PURPOSE, AND NON-INFRINGEMENT OF ANY THIRD PARTY INTELLECTUAL PROPERTY RIGHTS. TI SHALL NOT BE LIABLE FOR AND SHALL NOT DEFEND OR INDEMNIFY DESIGNER AGAINST ANY CLAIM, INCLUDING BUT NOT LIMITED TO ANY INFRINGEMENT CLAIM THAT RELATES TO OR IS BASED ON ANY COMBINATION OF PRODUCTS EVEN IF DESCRIBED IN TI RESOURCES OR OTHERWISE. IN NO EVENT SHALL TI BE LIABLE FOR ANY ACTUAL, DIRECT, SPECIAL, COLLATERAL, INDIRECT, PUNITIVE, INCIDENTAL, CONSEQUENTIAL OR EXEMPLARY DAMAGES IN CONNECTION WITH OR ARISING OUT OF TI RESOURCES OR USE THEREOF, AND REGARDLESS OF WHETHER TI HAS BEEN ADVISED OF THE POSSIBILITY OF SUCH DAMAGES.

Unless TI has explicitly designated an individual product as meeting the requirements of a particular industry standard (e.g., ISO/TS 16949 and ISO 26262), TI is not responsible for any failure to meet such industry standard requirements.

Where TI specifically promotes products as facilitating functional safety or as compliant with industry functional safety standards, such products are intended to help enable customers to design and create their own applications that meet applicable functional safety standards and requirements. Using products in an application does not by itself establish any safety features in the application. Designers must ensure compliance with safety-related requirements and standards applicable to their applications. Designer may not use any TI products in life-critical medical equipment unless authorized officers of the parties have executed a special contract specifically governing such use. Life-critical medical equipment is medical equipment where failure of such equipment would cause serious bodily injury or death (e.g., life support, pacemakers, defibrillators, heart pumps, neurostimulators, and implantables). Such equipment includes, without limitation, all medical devices identified by the U.S. Food and Drug Administration as Class III devices and equivalent classifications outside the U.S.

TI may expressly designate certain products as completing a particular qualification (e.g., Q100, Military Grade, or Enhanced Product). Designers agree that it has the necessary expertise to select the product with the appropriate qualification designation for their applications and that proper product selection is at Designers' own risk. Designers are solely responsible for compliance with all legal and regulatory requirements in connection with such selection.

Designer will fully indemnify TI and its representatives against any damages, costs, losses, and/or liabilities arising out of Designer's non-compliance with the terms and provisions of this Notice.