

# LM26420 Dual 2-A, High-Efficiency Synchronous DC/DC Converter

## 1 Features

- Compliant with CISPR25 Class 5 Conducted Emissions
- Input Voltage Range of 3 V to 5.5 V
- Output Voltage Range of 0.8 V to 4.5 V
- 2-A Output Current per Regulator
- High Switching Frequency: 2.2 MHz (LM26420X) 0.55 MHz (LM26420Y)
- 0.8 V, 1.5% Internal Voltage Reference
- Internal Soft Start
- Independent Power Good and Precision Enable for Each Output
- Current Mode, PWM Operation
- Thermal Shutdown
- Overvoltage Protection
- Start-up into Prebiased Output Loads
- Regulators are 180° Out of Phase
- Create a Custom Design Using the LM26420 With the [WEBENCH® Power Designer](#)

## 2 Applications

- Local 5 V to Vcore of FPGAs
- Core Power in HDDs and Set-Top Boxes
- USB Powered Devices
- Powering Core and I/O Voltages for CPUs and ASICs

## 3 Description

The LM26420 regulator is a monolithic, high-efficiency dual PWM step-down DC/DC converter. This device has the ability to drive two 2-A loads with an internal 75-mΩ PMOS top switch and an internal 50-mΩ NMOS bottom switch using state-of-the-art BICMOS technology results in the best power density available. The world-class control circuitry allow on times as low as 30 ns, thus supporting exceptionally high-frequency conversion over the entire 3-V to 5.5-V input operating range down to the minimum output voltage of 0.8 V.

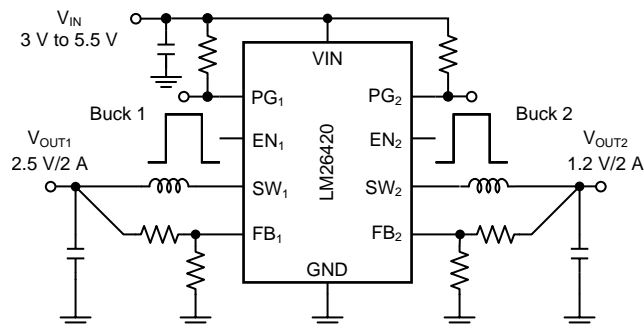
Although the operating frequency is high, efficiencies up to 93% are easy to achieve. External shutdown is included, featuring an ultra-low standby current. The LM26420 utilizes current-mode control and internal compensation to provide high performance regulation over a wide range of operating conditions.

### Device Information<sup>(1)</sup>

PART NUMBER	PACKAGE	BODY SIZE (NOM)
LM26420	HTSSOP (20)	6.50 mm × 4.40 mm
	WQFN (16)	4.00 mm × 4.00 mm

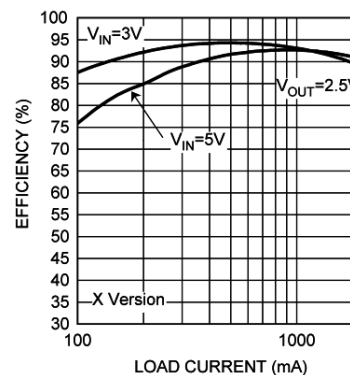
(1) For all available packages, see the orderable addendum at the end of the data sheet.

LM26420 Dual Buck DC/DC Converter



Copyright © 2016, Texas Instruments Incorporated

LM26420 Efficiency (Up to 93%)



## Table of Contents

<b>1 Features</b> .....	<b>1</b>	<b>8 Application and Implementation</b> .....	<b>16</b>
<b>2 Applications</b> .....	<b>1</b>	8.1 Application Information.....	16
<b>3 Description</b> .....	<b>1</b>	8.2 Typical Applications .....	19
<b>4 Revision History</b> .....	<b>2</b>	<b>9 Power Supply Recommendations</b> .....	<b>32</b>
<b>5 Pin Configuration and Functions</b> .....	<b>4</b>	<b>10 Layout</b> .....	<b>32</b>
<b>6 Specifications</b> .....	<b>6</b>	10.1 Layout Guidelines .....	32
6.1 Absolute Maximum Ratings .....	6	10.2 Layout Example .....	33
6.2 ESD Ratings (LM26420X/Y) .....	6	10.3 Thermal Considerations .....	33
6.3 Recommended Operating Conditions.....	6	<b>11 Device and Documentation Support</b> .....	<b>36</b>
6.4 Thermal Information .....	6	11.1 Device Support.....	36
6.5 Electrical Characteristics Per Buck.....	7	11.2 Documentation Support .....	36
6.6 Typical Characteristics.....	8	11.3 Receiving Notification of Documentation Updates	36
<b>7 Detailed Description</b> .....	<b>13</b>	11.4 Community Resources.....	36
7.1 Overview .....	13	11.5 Trademarks .....	36
7.2 Functional Block Diagram .....	14	11.6 Electrostatic Discharge Caution.....	37
7.3 Feature Description.....	14	11.7 Glossary .....	37
7.4 Device Functional Modes.....	15	<b>12 Mechanical, Packaging, and Orderable Information</b> .....	<b>37</b>

## 4 Revision History

Changes from Revision K (April 2016) to Revision L	Page
• Split automotive data sheet to separate document (SNVSB35) and remove automotive-specific content from SNVS579 .....	1
• Added links for WEBENCH .....	1

Changes from Revision J (September 2015) to Revision K	Page
• Changed $R_{\theta JA}$ value from 35°C/W to 38.5°C/W for PWP package and from 40°C/W to 36.2°C/W; replaced $R_{\theta JC}$ values with 2 new rows (and new values); added additional thermal values.....	6
• Changed "C1" to "C2" on Figure 42 .....	20
• Changed "C1" to "C2" on Figure 51 .....	29
• Deleted "C7" and "C8" from Table 6 .....	30

Changes from Revision I (June 2015) to Revision J	Page
• fixed error in WQFN <i>Pin Functions</i> - shifted "Description" column down one row and added back description for $VIND_1$ pin .....	4
• Changed reference from "Typical Applications" to "Table 1". .....	22
• Deleted definition for $R_{DS}$ (not part of equation 15) .....	22

Changes from Revision H (August 2014) to Revision I	Page
• Changed "Frequency" to "Efficiency" in title; add new Feature bullet re: CISPR25.....	1
• Changed moved Storage temperature to <i>Absolute Maximum Ratings</i> table .....	6
• Changed figure 36 caption .....	13
• Added part number to caption wording .....	14
• Added application note .....	16
• Changed title of <i>Thermal Guidelines</i> to <i>Thermal Considerations</i> and moved the section to the correct location.....	33

- Added *Related Documentation* and *Community Resources* subsections ..... 36
- 

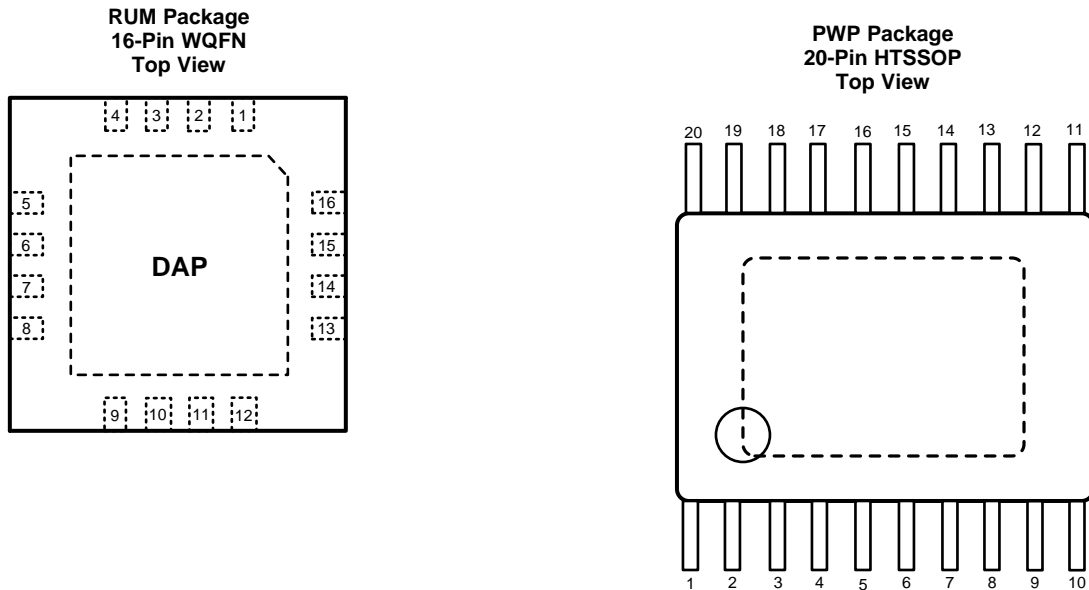
**Changes from Revision G (July 2014) to Revision H**
**Page**

- Changed percent sign to suffix ..... 7
- 

**Changes from Revision F (March 2013) to Revision G**
**Page**

- Changed formatting to match new TI datasheet guidelines; added *Device Information* and *Handling Ratings* tables, *Layout*, and *Device and Documentation Support* sections; reformatted *Functional Description* to *Detailed Description* and *Applications* to *Applications and Implementation* sections ..... 1
  - Changed to new equation..... 34
-

## 5 Pin Configuration and Functions



**Pin Functions: 16-Pin WQFN**

PIN		TYPE	DESCRIPTION
NUMBER	NAME		
1,2	VIND <sub>1</sub>	P	Power input supply for Buck 1.
3	SW <sub>1</sub>	P	Output switch for Buck 1. Connect to the inductor.
4	PGND <sub>1</sub>	G	Power ground pin for Buck 1.
5	FB <sub>1</sub>	A	Feedback pin for Buck 1. Connect to external resistor divider to set output voltage.
6	PG <sub>1</sub>	G	Power Good Indicator for Buck 1. Pin is connected through a resistor to an external supply (open drain output).
7	PG <sub>2</sub>	G	Power Good Indicator for Buck 2. Pin is connected through a resistor to an external supply (open drain output).
8	FB <sub>2</sub>	A	Feedback pin for Buck 2. Connect to external resistor divider to set output voltage.
9	PGND <sub>2</sub>	G	Power ground pin for Buck 2.
10	SW <sub>2</sub>	P	Output switch for Buck 2. Connect to the inductor.
11, 12	VIND <sub>2</sub>	A	Power Input supply for Buck 2.
13	EN <sub>2</sub>	A	Enable control input. Logic high enable operation for Buck 2. Do not allow this pin to float or be greater than V <sub>IN</sub> + 0.3 V.
14	AGND	G	Signal ground pin. Place the bottom resistor of the feedback network as close as possible to pin.
15	VINC	A	Input supply for control circuitry.
16	EN <sub>1</sub>	A	Enable control input. Logic high enable operation for Buck 1. Do not allow this pin to float or be greater than V <sub>IN</sub> + 0.3 V.
DAP	Die Attach Pad	—	Connect to system ground for low thermal impedance and as a primary electrical GND connection.

**Pin Functions 20-Pin HTSSOP**

PIN		TYPE	DESCRIPTION
NUMBER	NAME		
1	VINC	A	Input supply for control circuitry.
2	EN <sub>1</sub>	A	Enable control input. Logic high enable operation for Buck 1. Do not allow this pin to float or be greater than $V_{IN} + 0.3\text{ V}$ .
3, 4	VIND <sub>1</sub>	A	Power Input supply for Buck 1.
5	SW <sub>1</sub>	P	Output switch for Buck 1. Connect to the inductor.
6,7	PGND <sub>1</sub>	G	Power ground pin for Buck 1.
8	FB <sub>1</sub>	A	Feedback pin for Buck 1. Connect to external resistor divider to set output voltage.
9	PG <sub>1</sub>	G	Power Good Indicator for Buck 1. Pin is connected through a resistor to an external supply (open drain output).
10, 11, DAP	Die Attach Pad	—	Connect to system ground for low thermal impedance, but it cannot be used as a primary GND connection.
12	PG <sub>2</sub>	G	Power Good Indicator for Buck 2. Pin is connected through a resistor to an external supply (open drain output).
13	FB <sub>2</sub>	A	Feedback pin for Buck 2. Connect to external resistor divider to set output voltage.
14, 15	PGND <sub>2</sub>	G	Power ground pin for Buck 2.
16	SW <sub>2</sub>	P	Output switch for Buck 2. Connect to the inductor.
17, 18	VIND <sub>2</sub>	A	Power Input supply for Buck 2.
19	EN <sub>2</sub>	A	Enable control input. Logic high enable operation for Buck 2. Do not allow this pin to float or be greater than $V_{IN} + 0.3\text{ V}$ .
20	AGND	G	Signal ground pin. Place the bottom resistor of the feedback network as close as possible to pin.

## 6 Specifications

### 6.1 Absolute Maximum Ratings

Over operating free-air temperature range (unless otherwise noted)<sup>(1)</sup>

		MIN	MAX	UNIT
Input voltages	V <sub>IN</sub>	-0.5	7	V
	FB	-0.5	3	
	EN	-0.5	7	
Output voltages	SW	-0.5	7	V
Infrared or convection reflow (15 sec)	Soldering Information		220	°C
Storage temperature T <sub>stg</sub>		-65	150	°C

(1) Stresses beyond those listed under *Absolute Maximum Ratings* may cause permanent damage to the device. These are stress ratings only, which do not imply functional operation of the device at these or any other conditions beyond those indicated under *Recommended Operating Conditions*. Exposure to absolute-maximum-rated conditions for extended periods may affect device reliability.

### 6.2 ESD Ratings (LM26420X/Y)

		VALUE	UNIT
V <sub>(ESD)</sub> Electrostatic discharge	Human-body model (HBM), per ANSI/ESDA/JEDEC JS-001 <sup>(1)</sup>	±2000	V
	Charged-device model (CDM), per JEDEC specification JESD22-C101 <sup>(2)</sup>	±750	

(1) JEDEC document JEP155 states that 500-V HBM allows safe manufacturing with a standard ESD control process.

(2) JEDEC document JEP157 states that 250-V CDM allows safe manufacturing with a standard ESD control process.

### 6.3 Recommended Operating Conditions

Over operating free-air temperature range (unless otherwise noted)

		MIN	MAX	UNIT
V <sub>IN</sub>		3	5.5	V
Junction temperature (Q1)		-40	125	°C
Junction temperature (Q0)		-40	150	

### 6.4 Thermal Information

THERMAL METRIC <sup>(1)</sup>		LM26420		UNIT
		PWP (HTSSOP)	RUM (WQFN)	
		20 PINS	16 PINS	
R <sub>θJA</sub>	Junction-to-ambient thermal resistance	38.5	36.2	°C/W
R <sub>θJC(top)</sub>	Junction-to-case thermal resistance	21.0	32.7	°C/W
R <sub>θJB</sub>	Junction-to-board thermal resistance	19.9	14.1	°C/W
ψ <sub>JT</sub>	Junction-to-top characterization parameter	0.7	0.3	°C/W
ψ <sub>JB</sub>	Junction-to-board characterization parameter	19.7	14.2	°C/W
R <sub>θJC(bot)</sub>	Junction-to-case (bottom) thermal resistance	3.5	4.1	°C/W

(1) For more information about traditional and new thermal metrics, see the *Semiconductor and IC Package Thermal Metrics* application report.

## 6.5 Electrical Characteristics Per Buck

Over operating free-air temperature range (unless otherwise noted)

PARAMETER		TEST CONDITIONS	MIN	TYP	MAX	UNIT
V <sub>FB</sub>	Feedback Voltage		0.788	0.8	0.812	V
ΔV <sub>FB</sub> /V <sub>IN</sub>	Feedback Voltage Line Regulation	V <sub>IN</sub> = 3 V to 5.5 V		0.05		%/V
I <sub>B</sub>	Feedback Input Bias Current			0.4	100	nA
UVLO	Undervoltage Lockout	V <sub>IN</sub> Rising		2.628	2.9	V
		V <sub>IN</sub> Falling	2	2.3		V
	UVLO Hysteresis			330		mV
F <sub>SW</sub>	Switching Frequency	LM26420-X	1.85	2.2	2.65	MHz
F <sub>SW</sub>	Switching Frequency	LM26420-Y	0.4	0.55	0.7	
F <sub>FB</sub>	Frequency Foldback	LM26420-X		300		kHz
F <sub>FB</sub>	Frequency Foldback	LM26420-Y		150		
D <sub>MAX</sub>	Maximum Duty Cycle	LM26420-X	86%	91.5%		
D <sub>MAX</sub>	Maximum Duty Cycle	LM26420-Y	90%	98%		
R <sub>DS(on)_TOP</sub>	TOP Switch On Resistance	WQFN-16 Package		75	135	mΩ
		HTSSOP-20 Package		70	135	
R <sub>DS(on)_BOT</sub>	BOTTOM Switch On Resistance	WQFN-16 Package		55	100	mΩ
		TSSOP-20 Package		45	80	
I <sub>CL_TOP</sub>	TOP Switch Current Limit	V <sub>IN</sub> = 3.3 V	2.4	3.3		A
I <sub>CL_BOT</sub>	BOTTOM Switch Reverse Current Limit	V <sub>IN</sub> = 3.3 V	0.4	0.75		A
ΔΦ	Phase Shift Between SW <sub>1</sub> and SW <sub>2</sub>		160	180	200	°
V <sub>EN_TH</sub>	Enable Threshold Voltage		0.97	1.04	1.12	V
	Enable Threshold Hysteresis			0.15		
I <sub>SW_TOP</sub>	Switch Leakage			-0.7		μA
I <sub>EN</sub>	Enable Pin Current	Sink/Source		5		nA
V <sub>PG-TH-U</sub>	Upper Power Good Threshold	FB Pin Voltage Rising	848	925	1,008	mV
	Upper Power Good Hysteresis			40		
V <sub>PG-TH-L</sub>	Lower Power Good Threshold	FB Pin Voltage Rising	656	710	791	mV
	Lower Power Good Hysteresis			40		
I <sub>QVINC</sub>	VINC Quiescent Current (non-switching) with both outputs on	LM26420X/Y V <sub>FB</sub> = 0.9 V		3.3	5	mA
	VINC Quiescent Current (switching) with both outputs on	LM26420X/Y V <sub>FB</sub> = 0.7 V		4.7	6.2	
	VINC Quiescent Current (shutdown)	All Options V <sub>EN</sub> = 0 V			0.05	μA
I <sub>QVIND</sub>	VIND Quiescent Current (non-switching)	LM26420X/Y V <sub>FB</sub> = 0.9 V		0.9	1.5	mA
	VIND Quiescent Current (switching)	LM26420X V <sub>FB</sub> = 0.7 V		11	15	
I <sub>QVIND</sub>	VIND Quiescent Current (switching)	LM26420Y V <sub>FB</sub> = 0.7 V		3.7	7.5	mA
I <sub>QVIND</sub>	VIND Quiescent Current (shutdown)	All Options V <sub>EN</sub> = 0 V		0.1		μA
T <sub>SD</sub>	Thermal Shutdown Temperature			165		°C

### 6.6 Typical Characteristics

All curves taken at  $V_{IN} = 5\text{V}$  with configuration in typical application circuits shown in *Application and Implementation*.  $T_J = 25^\circ\text{C}$ , unless otherwise specified.

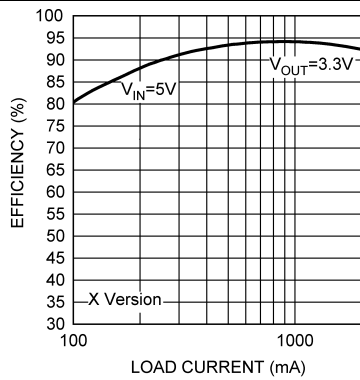


Figure 1. Efficiency vs Load, X Option

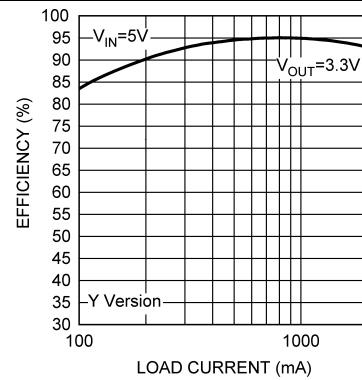


Figure 2. Efficiency vs Load, Y Option

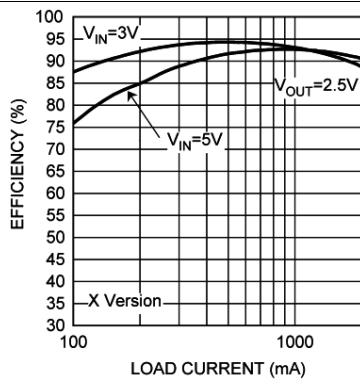


Figure 3. Efficiency vs Load, X Option

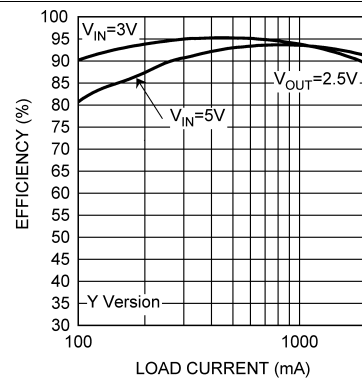


Figure 4. Efficiency vs Load, Y Option

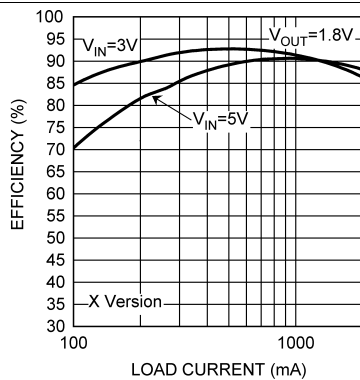


Figure 5. Efficiency vs Load, X Option

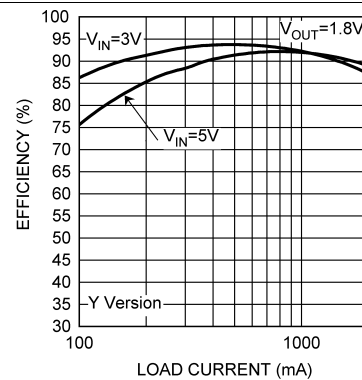


Figure 6. Efficiency vs Load, Y Option



Typical Characteristics (continued)

All curves taken at  $V_{IN} = 5\text{ V}$  with configuration in typical application circuits shown in *Application and Implementation*.  $T_J = 25^\circ\text{C}$ , unless otherwise specified.

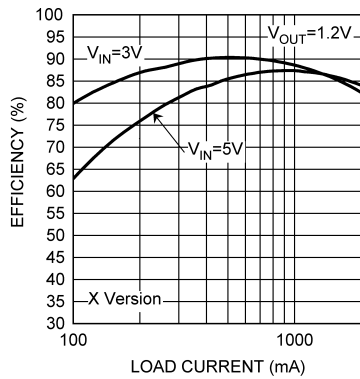


Figure 7. Efficiency vs Load, X Option

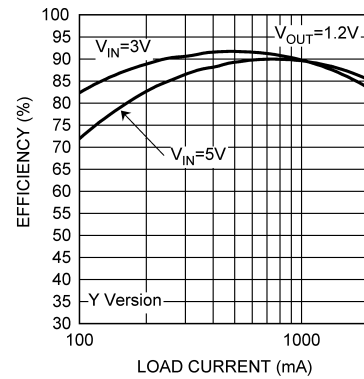


Figure 8. Efficiency vs Load, Y Option

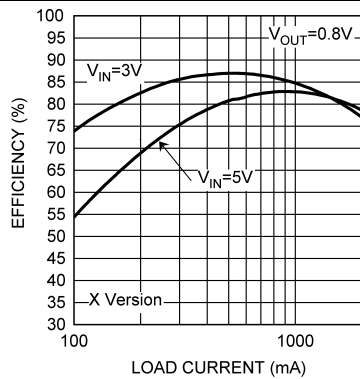


Figure 9. Efficiency vs Load, X Option

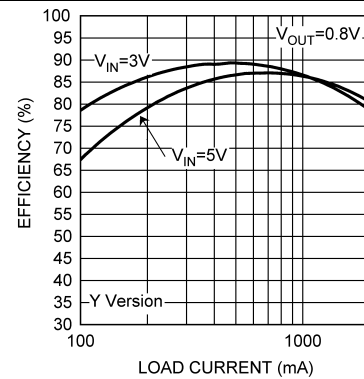


Figure 10. Efficiency vs Load, Y Option

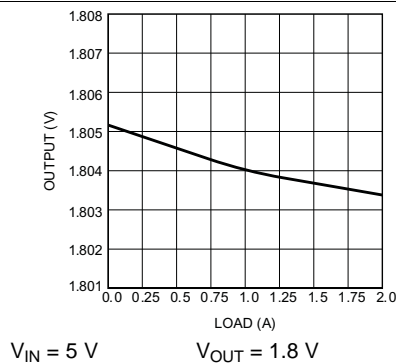


Figure 11. Load Regulation (All Options)

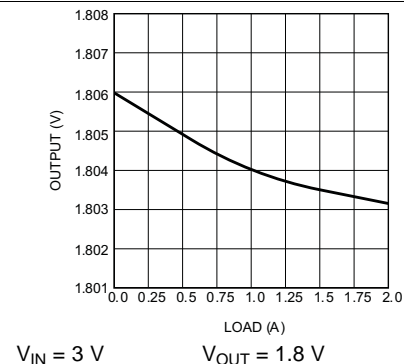


Figure 12. Load Regulation (All Options)

### Typical Characteristics (continued)

All curves taken at  $V_{IN} = 5\text{ V}$  with configuration in typical application circuits shown in [Application and Implementation](#).  $T_J = 25^\circ\text{C}$ , unless otherwise specified.

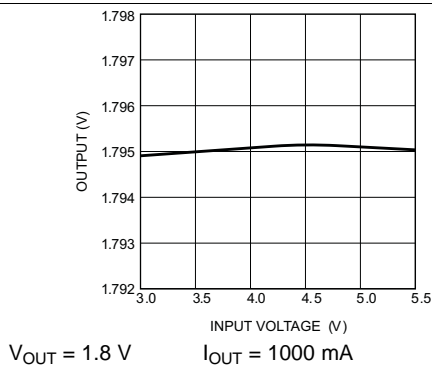


Figure 13. Line Regulation, X Option

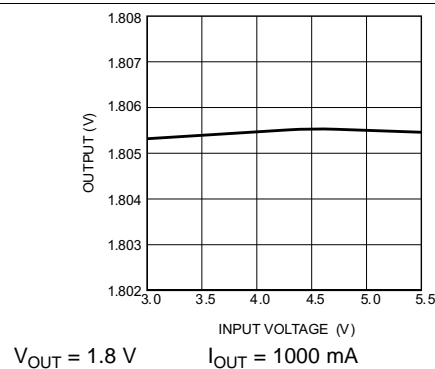


Figure 14. Line Regulation - Y Option

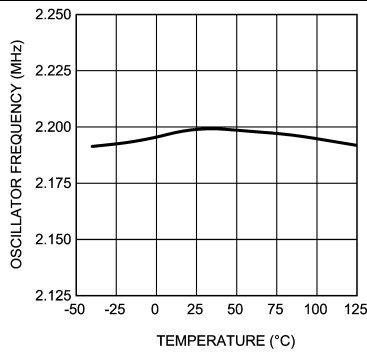


Figure 15. Oscillator Frequency vs Temperature, X Option

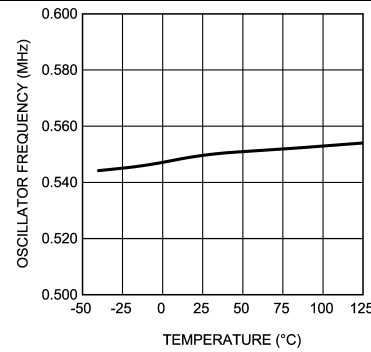


Figure 16. Oscillator Frequency vs Temperature, Y Option

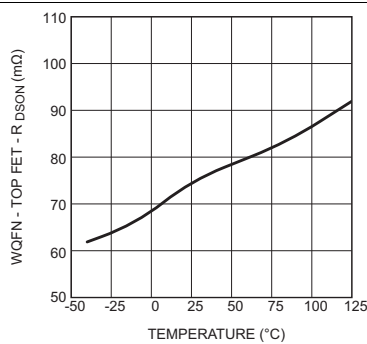


Figure 17.  $R_{DS(on)}$  Top Vs Temperature (WQFN-16 Package)

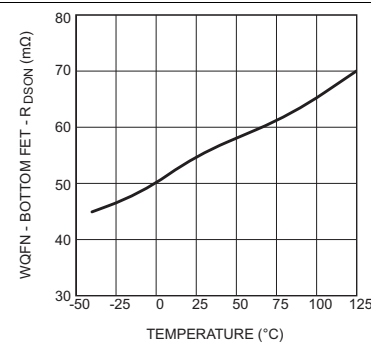


Figure 18.  $R_{DS(on)}$  Bottom Vs Temperature (WQFN-16 Package)

Typical Characteristics (continued)

All curves taken at  $V_{IN} = 5\text{ V}$  with configuration in typical application circuits shown in *Application and Implementation*.  $T_J = 25^\circ\text{C}$ , unless otherwise specified.

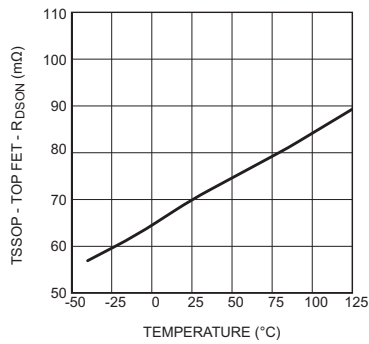


Figure 19.  $R_{DS(on)}$  Top vs Temperature (TSSOP-20 Package)

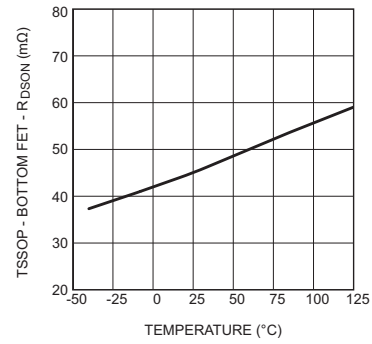


Figure 20.  $R_{DS(on)}$  Bottom vs Temperature (TSSOP-20 Package)

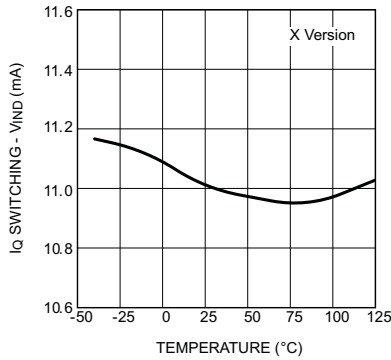


Figure 21.  $I_Q$  (Quiescent Current Switching), X Option

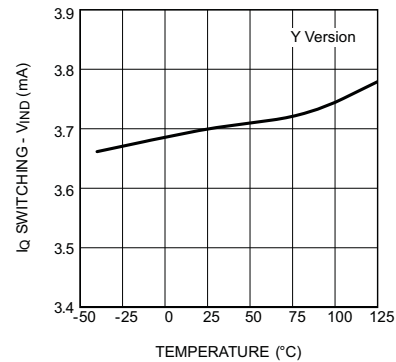


Figure 22.  $I_Q$  (Quiescent Current Switching), Y Option

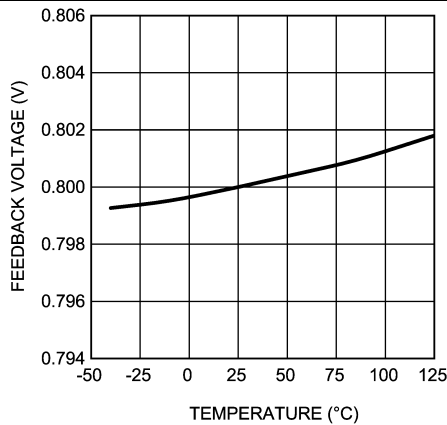
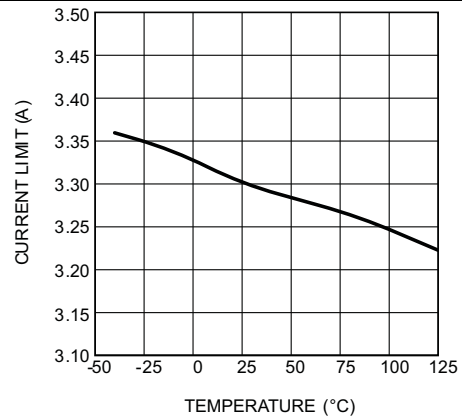


Figure 23.  $V_{FB}$  vs Temperature

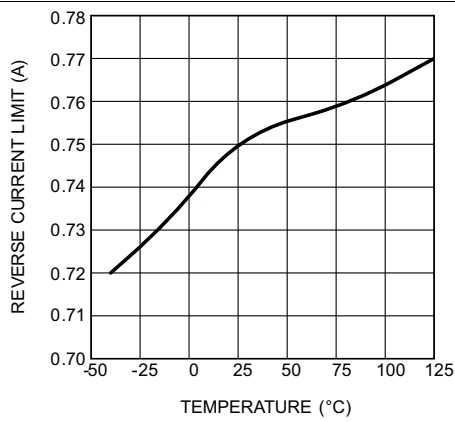


$V_{IN} = 5\text{ V}$  and  $3.3\text{ V}$

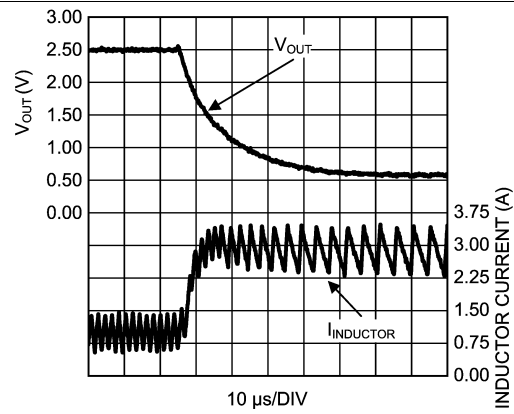
Figure 24. Current Limit vs Temperature

### Typical Characteristics (continued)

All curves taken at  $V_{IN} = 5\text{ V}$  with configuration in typical application circuits shown in [Application and Implementation](#).  $T_J = 25^\circ\text{C}$ , unless otherwise specified.



**Figure 25. Reverse Current Limit vs Temperature**



**Figure 26. Short Circuit Waveforms**

## 7 Detailed Description

### 7.1 Overview

The LM26420 is a constant frequency dual PWM buck synchronous regulator device that can supply two loads at up to 2 A each. The regulator has a preset switching frequency of either 2.2 MHz or 550 kHz. This high frequency allows the LM26420 to operate with small surface mount capacitors and inductors, resulting in a DC/DC converter that requires a minimum amount of board space. The LM26420 is internally compensated, so it is simple to use and requires few external components. The LM26420 uses current-mode control to regulate the output voltage. The following operating description of the LM26420 refers to the [Functional Block Diagram](#), which depicts the functional blocks for one of the two channels, and to the waveforms in [Figure 27](#). The LM26420 supplies a regulated output voltage by switching the internal PMOS and NMOS switches at constant frequency and variable duty cycle. A switching cycle begins at the falling edge of the reset pulse generated by the internal clock. When this pulse goes low, the output control logic turns on the internal PMOS control switch (TOP Switch). During this on-time, the SW pin voltage ( $V_{SW}$ ) swings up to approximately  $V_{IN}$ , and the inductor current ( $I_L$ ) increases with a linear slope.  $I_L$  is measured by the current sense amplifier, which generates an output proportional to the switch current. The sense signal is summed with the regulator's corrective ramp and compared to the error amplifier's output, which is proportional to the difference between the feedback voltage and  $V_{REF}$ . When the PWM comparator output goes high, the TOP Switch turns off and the NMOS switch (BOTTOM Switch) turns on after a short delay, which is controlled by the Dead-Time-Control Logic, until the next switching cycle begins. During the top switch off-time, inductor current discharges through the BOTTOM Switch, which forces the SW pin to swing to ground. The regulator loop adjusts the duty cycle ( $D$ ) to maintain a constant output voltage.

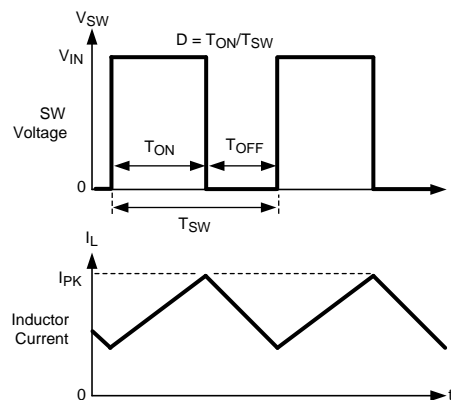
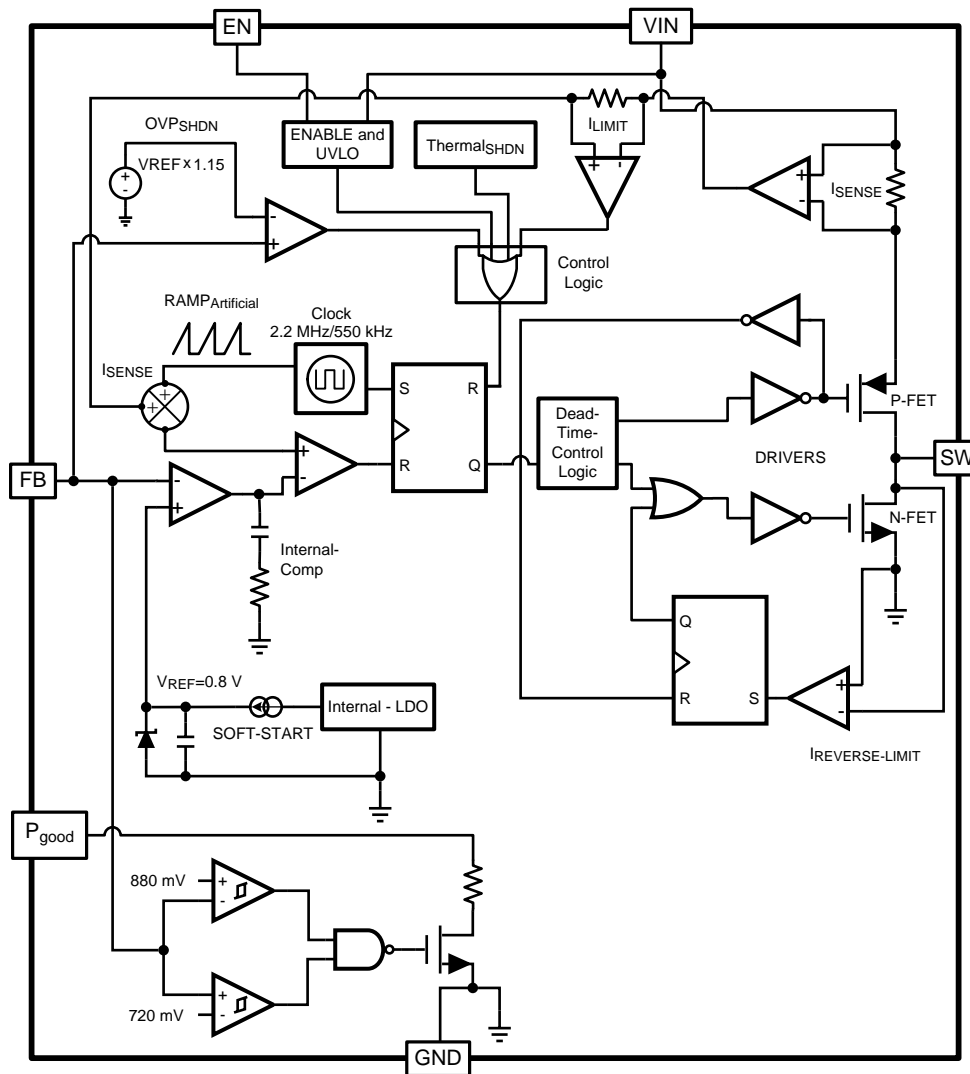


Figure 27. LM26420 Basic Operation of the PWM Comparator

## 7.2 Functional Block Diagram



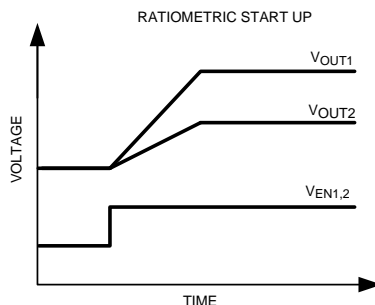
Copyright © 2016, Texas Instruments Incorporated

## 7.3 Feature Description

### 7.3.1 Soft Start

This function forces  $V_{OUT}$  to increase at a controlled rate during start-up in a controlled fashion, which helps reduce inrush current and eliminate overshoot on  $V_{OUT}$ . During soft start, reference voltage of the error amplifier ramps from 0 V to its nominal value of 0.8 V in approximately 600  $\mu$ s. If the converter is turned on into a pre-biased load, then the feedback begins ramping from the prebias voltage but at the same rate as if it had started from 0 V. The two outputs start up ratiometrically if enabled at the same time, see [Figure 28](#) below.

## Feature Description (continued)



**Figure 28. LM26420 Soft-Start**

### 7.3.2 Power Good

The LM26420 features an open drain power good (PG) pin to sequence external supplies or loads and to provide fault detection. This pin requires an external resistor ( $R_{PG}$ ) to pull PG high when the output is within the PG tolerance window. Typical values for this resistor range from 10 k $\Omega$  to 100 k $\Omega$ .

### 7.3.3 Precision Enable

The LM26420 features independent precision enables that allow the converter to be controlled by an external signal. This feature allows the device to be sequenced either by an external control signal or the output of another converter in conjunction with a resistor divider network. It can also be set to turn on at a specific input voltage when used in conjunction with a resistor divider network connected to the input voltage. The device is enabled when the EN pin exceeds 1.04 V and has a 150-mV hysteresis.

## 7.4 Device Functional Modes

### 7.4.1 Output Overvoltage Protection

The overvoltage comparator compares the FB pin voltage to a voltage that is approximately 15% greater than the internal reference  $V_{REF}$ . Once the FB pin voltage goes 15% above the internal reference, the internal PMOS switch is turned off, which allows the output voltage to decrease toward regulation.

### 7.4.2 Undervoltage Lockout

Undervoltage lockout (UVLO) prevents the LM26420 from operating until the input voltage exceeds 2.628 V (typical). The UVLO threshold has approximately 330 mV of hysteresis, so the device operates until  $V_{IN}$  drops below 2.3 V (typical). Hysteresis prevents the part from turning off during power up if  $V_{IN}$  is non-monotonic.

### 7.4.3 Current Limit

The LM26420 uses cycle-by-cycle current limiting to protect the output switch. During each switching cycle, a current limit comparator detects if the output switch current exceeds 3.3 A (typical), and turns off the switch until the next switching cycle begins.

### 7.4.4 Thermal Shutdown

Thermal shutdown limits total power dissipation by turning off the output switch when the device junction temperature exceeds 165°C. After thermal shutdown occurs, the output switch does not turn on until the junction temperature drops to approximately 150°C.

## 8 Application and Implementation

### NOTE

Information in the following applications sections is not part of the TI component specification, and TI does not warrant its accuracy or completeness. TI's customers are responsible for determining suitability of components for their purposes. Customers should validate and test their design implementation to confirm system functionality.

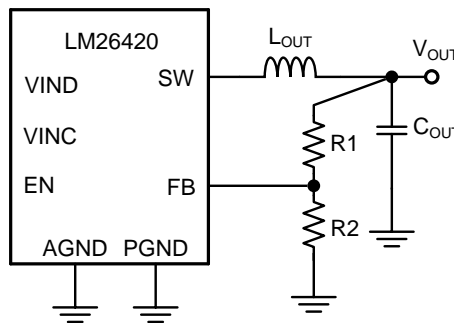
### 8.1 Application Information

#### 8.1.1 Programming Output Voltage

The output voltage is set using Equation 1 where R2 is connected between the FB pin and GND, and R1 is connected between V<sub>OUT</sub> and the FB pin. A good value for R2 is 10 kΩ. When designing a unity gain converter (V<sub>OUT</sub> = 0.8 V), R1 must be between 0 Ω and 100 Ω, and R2 must be on the order of 5 kΩ to 50 kΩ. 10 kΩ is the suggested value where R1 is the top feedback resistor and R2 is the bottom feedback resistor.

$$R1 = \left( \frac{V_{OUT}}{V_{REF}} - 1 \right) \times R2 \tag{1}$$

$$V_{REF} = 0.80V \tag{2}$$



Copyright © 2016, Texas Instruments Incorporated

**Figure 29. Programming V<sub>OUT</sub>**

To determine the maximum allowed resistor tolerance, use Equation 3:

$$\sigma = \left( \frac{1}{1 + 2x \frac{1 - \frac{V_{FB}}{V_{OUT}}}{TOL - \phi}} \right)$$

where

- TOL is the set point accuracy of the regulator, is the tolerance of V<sub>FB</sub>. (3)

Example:

V<sub>OUT</sub> = 2.5 V, with a setpoint accuracy of ±3.5%.

$$\sigma = \left( \frac{1}{1 + 2x \frac{1 - \frac{0.8V}{2.5V}}{3.5\% - 1.5\%}} \right) = 1.4\% \tag{4}$$

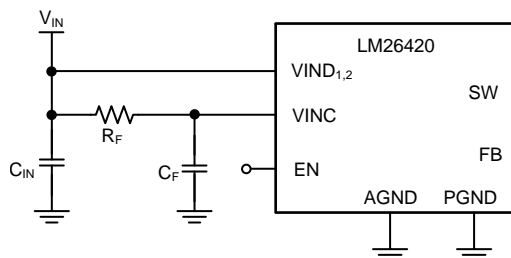
Choose 1% resistors. If R2 = 10 kΩ, then R1 is 21.25 kΩ.



## Application Information (continued)

### 8.1.2 VINC Filtering Components

Additional filtering is required between VINC and AGND in order to prevent high frequency noise on VIN from disturbing the sensitive circuitry connected to VINC. A small RC filter can be used on the VINC pin as shown in Figure 30.



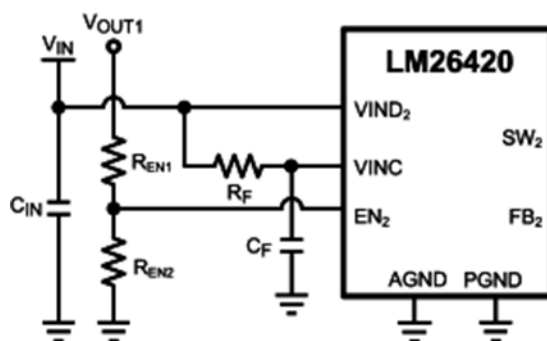
Copyright © 2016, Texas Instruments Incorporated

Figure 30. RC Filter On VINC

In general,  $R_F$  is typically between  $1\ \Omega$  and  $10\ \Omega$  so that the steady state voltage drop across the resistor due to the VINC bias current does not affect the UVLO level.  $C_F$  can range from  $0.22\ \mu\text{F}$  to  $1\ \mu\text{F}$  in X7R or X5R dielectric, where the RC time constant should be at least  $2\ \mu\text{s}$ .  $C_F$  must be placed as close to the device as possible with a direct connection from VINC and AGND.

### 8.1.3 Using Precision Enable and Power Good

The LM26420 device precision EN and PG pins address many of the sequencing requirements required in today's challenging applications. Each output can be controlled independently and have independent power good. This allows for a multitude of ways to control each output. Typically, the enables to each output are tied together to the input voltage and the outputs ratiometrically ramp up when the input voltage reaches above UVLO rising threshold. There may be instances where it is desired that the second output ( $V_{OUT2}$ ) does not turn on until the first output ( $V_{OUT1}$ ) has reached 90% of the desired setpoint. This is easily achieved with an external resistor divider attached from  $V_{OUT1}$  to  $EN_2$ , see Figure 31.



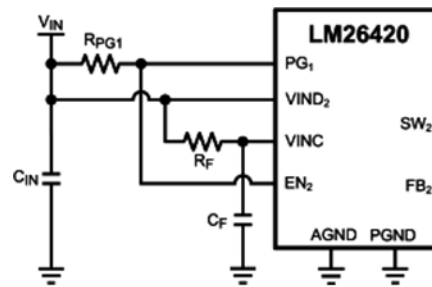
Copyright © 2016, Texas Instruments Incorporated

Figure 31.  $V_{OUT1}$  Controlling  $V_{OUT2}$  with Resistor Divider

If it is not desired to have a resistor divider to control  $V_{OUT2}$  with  $V_{OUT1}$ , then the  $PG_1$  can be connected to the  $EN_2$  pin to control  $V_{OUT2}$ , see Figure 32.  $R_{PG1}$  is a pullup resistor on the range of  $10\ \text{k}\Omega$  to  $100\ \text{k}\Omega$ ,  $50\ \text{k}\Omega$  is the suggested value. This turns on  $V_{OUT2}$  when  $V_{OUT1}$  is approximately 90% of the programmed output.

#### NOTE

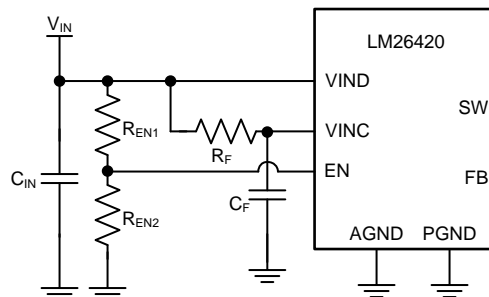
This also turns off  $V_{OUT2}$  when  $V_{OUT1}$  is outside the  $\pm 10\%$  of the programmed output.

**Application Information (continued)**


Copyright © 2016, Texas Instruments Incorporated

**Figure 32. PG<sub>1</sub> Controlling V<sub>OUT2</sub>**

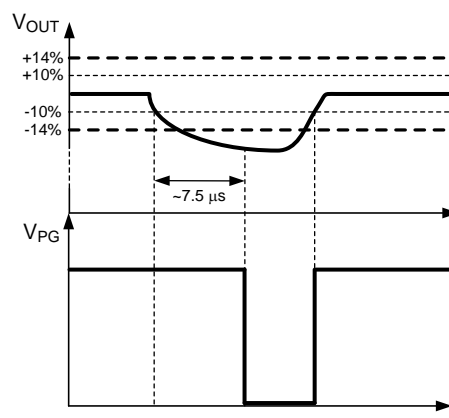
Another example might be that the output is not to be turned on until the input voltage reaches 90% of desired voltage setpoint. This verifies that the input supply is stable before turning on the output. Select R<sub>EN1</sub> and R<sub>EN2</sub> such that the voltage at the EN pin is greater than 1.12 V when reaching the 90% desired set-point.



Copyright © 2016, Texas Instruments Incorporated

**Figure 33. V<sub>OUT</sub> Controlling V<sub>IN</sub>**

The power good feature of the LM26420 is designed with hysteresis in order to ensure no false power good flags are asserted during large transient. Once power good is asserted high, it is not pulled low until the output voltage exceeds ±14% of the setpoint for a duration of approximately 7.5 μs (typical), see Figure 34.


**Figure 34. Power Good Hysteresis Operation**

## Application Information (continued)

### 8.1.4 Overcurrent Protection

When the switch current reaches the current limit value, it is turned off immediately. This effectively reduces the duty cycle and therefore the output voltage dips and continues to droop until the output load matches the peak current limit inductor current. As the FB voltage drops below 480 mV the operating frequency begins to decrease until it hits full on frequency foldback, which is set to approximately 150 kHz for the Y version and 300 kHz for the X version. Frequency foldback helps reduce the thermal stress in the device by reducing the switching losses and to prevent runaway of the inductor current when the output is shorted to ground.

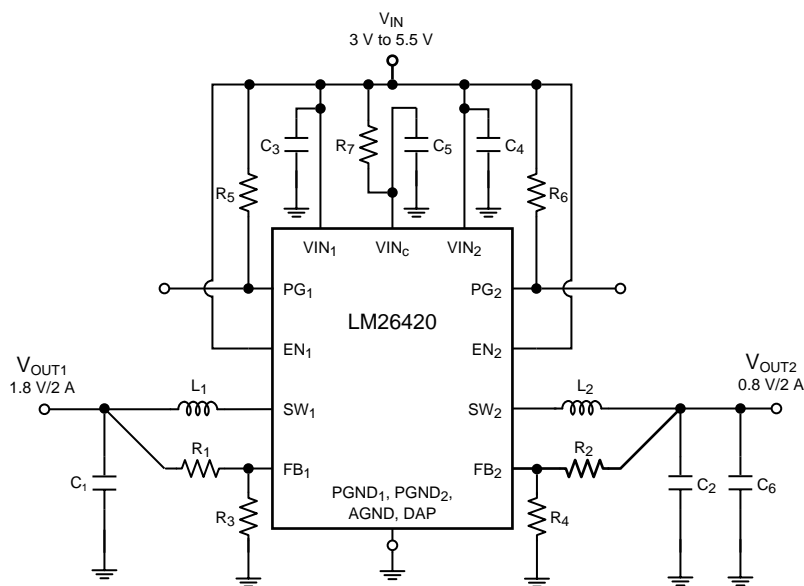
It is important to note that when recovering from an overcurrent condition the converter does not go through the soft-start process. There may be an overshoot due to the sudden removal of the overcurrent fault. The reference voltage at the non-inverting input of the error amplifier always sits at 0.8 V during the overcurrent condition, therefore when the fault is removed the converter bring the FB voltage back to 0.8 V as quickly as possible. The overshoot depend on whether there is a load on the output after the removal of the overcurrent fault, the size of the inductor, and the amount of capacitance on the output. The smaller the inductor and the larger the capacitance on the output the smaller the overshoot.

#### NOTE

Overcurrent protection for each output is independent.

## 8.2 Typical Applications

### 8.2.1 LM26420X 2.2-MHz, 0.8-V Typical High-Efficiency Application Circuit



Copyright © 2016, Texas Instruments Incorporated

Figure 35. LM26420X (2.2 MHz):  $V_{IN} = 5\text{ V}$ ,  $V_{OUT1} = 1.8\text{ V}$  at 2 A and  $V_{OUT2} = 0.8\text{ V}$  at 2 A

## Typical Applications (continued)

### 8.2.1.1 Design Requirements

Example requirements for typical synchronous DC/DC converter applications:

**Table 1. Design Parameters**

DESIGN PARAMETER	VALUE
$V_{OUT}$	Output voltage
$V_{IN}$ (minimum)	Maximum input voltage
$V_{IN}$ (maximum)	Minimum input voltage
$I_{OUT}$ (maximum)	Maximum output current
$f_{SW}$	Switching frequency

### 8.2.1.2 Detailed Design Procedure

#### 8.2.1.2.1 Custom Design With WEBENCH® Tools

[Click here](#) to create a custom design using the LM26420 device with the WEBENCH® Power Designer.

1. Start by entering the input voltage ( $V_{IN}$ ), output voltage ( $V_{OUT}$ ), and output current ( $I_{OUT}$ ) requirements.
2. Optimize the design for key parameters such as efficiency, footprint, and cost using the optimizer dial.
3. Compare the generated design with other possible solutions from Texas Instruments.

The WEBENCH Power Designer provides a customized schematic along with a list of materials with real-time pricing and component availability.

In most cases, these actions are available:

- Run electrical simulations to see important waveforms and circuit performance
- Run thermal simulations to understand board thermal performance
- Export customized schematic and layout into popular CAD formats
- Print PDF reports for the design, and share the design with colleagues

Get more information about WEBENCH tools at [www.ti.com/WBENCH](http://www.ti.com/WBENCH).

**Table 2. Bill Of Materials**

PART ID	PART VALUE	MANUFACTURER	PART NUMBER
U1	2-A buck regulator	TI	LM26420X
C3, C4	15 $\mu$ F, 6.3 V, 1206, X5R	TDK	C3216X5R0J156M
C1	33 $\mu$ F, 6.3 V, 1206, X5R	TDK	C3216X5R0J336M
C2, C6	22 $\mu$ F, 6.3 V, 1206, X5R	TDK	C3216X5R0J226M
C5	0.47 $\mu$ F, 10 V, 0805, X7R	Vishay	VJ0805Y474KXQCW1BC
L1	1.0 $\mu$ H, 7.9 A	TDK	RLF7030T-1R0M6R4
L2	0.7 $\mu$ H, 3.7 A	Coilcraft	LPS4414-701ML
R3, R4	10.0 k $\Omega$ , 0603, 1%	Vishay	CRCW060310K0F
R5, R6	49.9 k $\Omega$ , 0603, 1%	Vishay	CRCW060649K9F
R1	12.7 k $\Omega$ , 0603, 1%	Vishay	CRCW060312K7F
R7, R2	4.99 $\Omega$ , 0603, 1%	Vishay	CRCW06034R99F

### 8.2.1.2.2 Inductor Selection

The duty cycle (D) can be approximated as the ratio of output voltage ( $V_{OUT}$ ) to input voltage ( $V_{IN}$ ):

$$D = \frac{V_{OUT}}{V_{IN}} \quad (5)$$

The voltage drop across the internal NMOS (SW\_BOT) and PMOS (SW\_TOP) must be included to calculate a more accurate duty cycle. Calculate D by using the following formulas:

$$D = \frac{V_{OUT} + V_{SW\_BOT}}{V_{IN} + V_{SW\_BOT} - V_{SW\_TOP}} \quad (6)$$

$V_{SW\_TOP}$  and  $V_{SW\_BOT}$  can be approximated by:

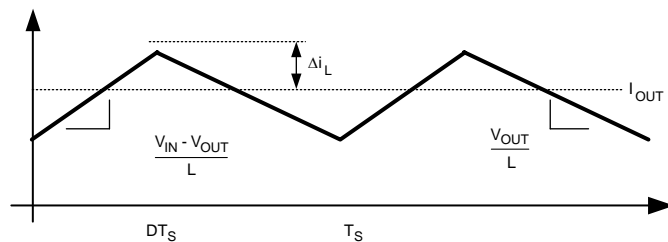
$$V_{SW\_TOP} = I_{OUT} \times R_{DS(on)\_TOP} \quad (7)$$

$$V_{SW\_BOT} = I_{OUT} \times R_{DS(on)\_BOT} \quad (8)$$

The inductor value determines the output ripple voltage. Smaller inductor values decrease the size of the inductor, but increase the output ripple voltage. An increase in the inductor value decreases the output ripple current.

One must ensure that the minimum current limit (2.4 A) is not exceeded, so the peak current in the inductor must be calculated. The peak current ( $I_{LPK}$ ) in the inductor is calculated by:

$$I_{LPK} = I_{OUT} + \Delta i_L \quad (9)$$



**Figure 36. Inductor Current**

$$\frac{V_{IN} - V_{OUT}}{L} = \frac{2\Delta i_L}{DT_S} \quad (10)$$

In general,

$$\Delta i_L = 0.1 \times (I_{OUT}) \rightarrow 0.2 \times (I_{OUT}) \quad (11)$$

If  $\Delta i_L = 20\%$  of 2 A, the peak current in the inductor is 2.4 A. The minimum ensured current limit over all operating conditions is 2.4 A. One can either reduce  $\Delta i_L$ , or make the engineering judgment that zero margin is safe enough. The typical current limit is 3.3 A.

The LM26420 operates at frequencies allowing the use of ceramic output capacitors without compromising transient response. Ceramic capacitors allow higher inductor ripple without significantly increasing output ripple voltage. See [Output Capacitor](#) section for more details on calculating output voltage ripple. Now that the ripple current is determined, the inductance is calculated by:

$$L = \left( \frac{DT_S}{2\Delta i_L} \right) \times (V_{IN} - V_{OUT}) \quad (12)$$

Where

$$T_S = \frac{1}{f_S} \quad (13)$$

When selecting an inductor, make sure that it is capable of supporting the peak output current without saturating. Inductor saturation results in a sudden reduction in inductance and prevent the regulator from operating correctly. The peak current of the inductor is used to specify the maximum output current of the inductor and saturation is not a concern due to the exceptionally small delay of the internal current limit signal. Ferrite based inductors are preferred to minimize core losses when operating with the frequencies used by the LM26420. This presents little restriction because the variety of ferrite-based inductors is huge. Lastly, inductors with lower series resistance ( $R_{DCR}$ ) provides better operating efficiency. For recommended inductors see [Table 2](#).

### 8.2.1.2.3 Input Capacitor Selection

The input capacitors provide the AC current needed by the nearby power switch so that current provided by the upstream power supply does not carry a lot of AC content, generating less EMI. To the buck regulator in question, the input capacitor also prevents the drain voltage of the FET switch from dipping when the FET is turned on, therefore providing a healthy line rail for the LM26420 to work with. Because typically most of the AC current is provided by the local input capacitors, the power loss in those capacitors can be a concern. In the case of the LM26420 regulator, because the two channels operate 180° out of phase, the AC stress in the input capacitors is less than if they operated in phase. The measure for the AC stress is called input ripple RMS current. It is strongly recommended that at least one 10µF ceramic capacitor be placed next to each of the VIND pins. Bulk capacitors such as electrolytic capacitors or OSCON capacitors can be added to help stabilize the local line voltage, especially during large load transient events. As for the ceramic capacitors, use X7R or X5R types. They maintain most of their capacitance over a wide temperature range. Try to avoid sizes smaller than 0805. Otherwise significant drop in capacitance may be caused by the DC bias voltage. See [Output Capacitor](#) section for more information. The DC voltage rating of the ceramic capacitor should be higher than the highest input voltage.

Capacitor temperature is a major concern in board designs. While using a 10-µF or higher MLCC as the input capacitor is a good starting point, it is a good idea to check the temperature in the real thermal environment to make sure the capacitors are not overheated. Capacitor vendors may provide curves of ripple RMS current vs. temperature rise, based on a designated thermal impedance. In reality, the thermal impedance may be very different. So it is always a good idea to check the capacitor temperature on the board.

Because the duty cycles of the two channels may overlap, calculation of the input ripple RMS current is a little tedious — use [Equation 14](#):

$$I_{\text{rms}} = \sqrt{(I_1 - I_{\text{av}})^2 d_1 + (I_2 - I_{\text{av}})^2 d_2 + (I_1 + I_2 - I_{\text{av}})^2 d_3}$$

where

- $I_1$  is Channel 1's maximum output current
- $I_2$  is Channel 2's maximum output current
- $d_1$  is the non-overlapping portion of Channel 1's duty cycle  $D_1$
- $d_2$  is the non-overlapping portion of Channel 2's duty cycle  $D_2$
- $d_3$  is the overlapping portion of the two duty cycles.
- $I_{\text{av}}$  is the average input current

(14)

$I_{\text{av}} = I_1 \times D_1 + I_2 \times D_2$ . To quickly determine the values of  $d_1$ ,  $d_2$  and  $d_3$ , refer to the decision tree in [Figure 37](#). To determine the duty cycle of each channel, use  $D = V_{\text{OUT}}/V_{\text{IN}}$  for a quick result or use the following equation for a more accurate result.

$$D = \frac{V_{\text{OUT}} + V_{\text{SW\_BOT}} + I_{\text{OUT}} \times R_{\text{DC}}}{V_{\text{IN}} + V_{\text{SW\_BOT}} - V_{\text{SW\_TOP}}}$$

where

- $R_{\text{DC}}$  is the winding resistance of the inductor.

(15)

Example:

$V_{\text{IN}} = 5 \text{ V}$ ,  $V_{\text{OUT}1} = 3.3 \text{ V}$ ,  $I_{\text{OUT}1} = 2 \text{ A}$ ,  $V_{\text{OUT}2} = 1.2 \text{ V}$ ,  $I_{\text{OUT}2} = 1.5 \text{ A}$ ,  $R_{\text{DS}} = 170 \text{ m}\Omega$ ,  $R_{\text{DC}} = 30 \text{ m}\Omega$ . ( $I_{\text{OUT}1}$  is the same as  $I_1$  in the input ripple RMS current equation,  $I_{\text{OUT}2}$  is the same as  $I_2$ ).

First, find out the duty cycles. Plug the numbers into the duty cycle equation and we get  $D_1 = 0.75$ , and  $D_2 = 0.33$ . Next, follow the decision tree in [Figure 37](#) to find out the values of  $d_1$ ,  $d_2$  and  $d_3$ . In this case,  $d_1 = 0.5$ ,  $d_2 = D_2 + 0.5 - D_1 = 0.08$ , and  $d_3 = D_1 - 0.5 = 0.25$ .  $I_{\text{av}} = I_{\text{OUT}1} \times D_1 + I_{\text{OUT}2} \times D_2 = 1.995 \text{ A}$ . Plug all the numbers into the input ripple RMS current equation and the result is  $I_{\text{R(rms)}} = 0.77 \text{ A}$ .

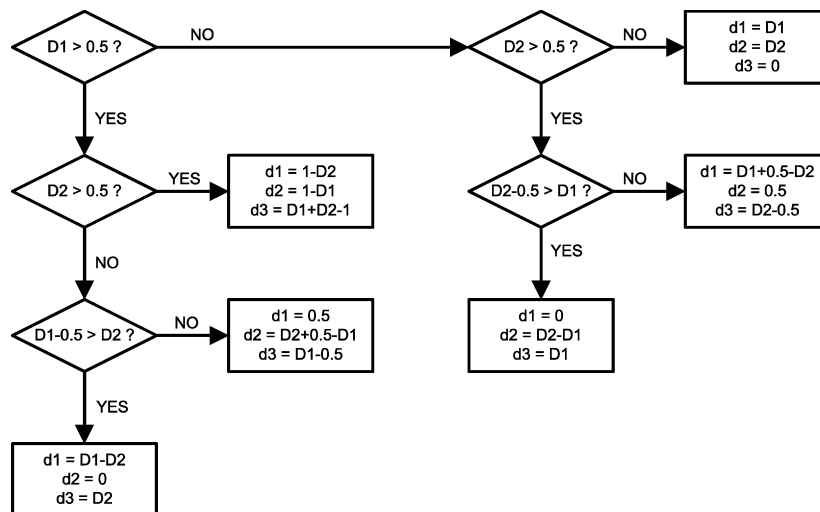


Figure 37. Determining D1, D2, And D3

8.2.1.2.4 Output Capacitor

The output capacitor is selected based upon the desired output ripple and transient response. The initial current of a load transient is provided mainly by the output capacitor. The output ripple of the converter is approximately:

$$\Delta V_{OUT} = \Delta I_L \left( R_{ESR} + \frac{1}{8 \times F_{SW} \times C_{OUT}} \right) \tag{16}$$

When using MLCCs, the ESR is typically so low that the capacitive ripple may dominate. When this occurs, the output ripple is approximately sinusoidal and 90° phase shifted from the switching action. Given the availability and quality of MLCCs and the expected output voltage of designs using the LM26420, there is really no need to review any other capacitor technologies. Another benefit of ceramic capacitors is their ability to bypass high frequency noise. A certain amount of switching edge noise couples through parasitic capacitances in the inductor to the output. A ceramic capacitor bypasses this noise while a tantalum capacitor does not. Because the output capacitor is one of the two external components that control the stability of the regulator control loop, most applications require a minimum of 22 μF of output capacitance. Capacitance often, but not always, can be increased significantly with little detriment to the regulator stability. Like the input capacitor, recommended multilayer ceramic capacitors are X7R or X5R types.

8.2.1.2.5 Calculating Efficiency and Junction Temperature

The complete LM26420 DC/DC converter efficiency can be estimated in the following manner.

$$\eta = \frac{P_{OUT}}{P_{IN}} \tag{17}$$

Or

$$\eta = \frac{P_{OUT}}{P_{OUT} + P_{LOSS}} \tag{18}$$

Calculations for determining the most significant power losses follow here. Other losses totaling less than 2% are not discussed.

Power loss (P<sub>LOSS</sub>) is the sum of two basic types of losses in the converter: switching and conduction. Conduction losses usually dominate at higher output loads, whereas switching losses remain relatively fixed and dominate at lower output loads. The first step in determining the losses is to calculate the duty cycle (D):

$$D = \frac{V_{OUT} + V_{SW\_BOT}}{V_{IN} + V_{SW\_BOT} - V_{SW\_TOP}} \tag{19}$$

V<sub>SW\_TOP</sub> is the voltage drop across the internal PFET when it is on, and is equal to:

$$V_{SW\_TOP} = I_{OUT} \times R_{DS(on)\_TOP} \tag{20}$$

$V_{SW\_BOT}$  is the voltage drop across the internal NFET when it is on, and is equal to:

$$V_{SW\_BOT} = I_{OUT} \times R_{DSON\_BOT} \quad (21)$$

If the voltage drop across the inductor ( $V_{DCR}$ ) is accounted for, the equation becomes:

$$D = \frac{V_{OUT} + V_{SW\_BOT} + V_{DCR}}{V_{IN} + V_{SW\_BOT} + V_{DCR} - V_{SW\_TOP}} \quad (22)$$

Another significant external power loss is the conduction loss in the output inductor. The equation can be simplified to:

$$P_{IND} = I_{OUT}^2 \times R_{DCR} \quad (23)$$

The LM26420 conduction loss is mainly associated with the two internal FETs:

$$P_{COND\_TOP} = (I_{OUT}^2 \times D) \left( 1 + \frac{1}{3} \times \left( \frac{\Delta i_L}{I_{OUT}} \right)^2 \right) R_{DSON\_TOP}$$

$$P_{COND\_BOT} = (I_{OUT}^2 \times (1-D)) \left( 1 + \frac{1}{3} \times \left( \frac{\Delta i_L}{I_{OUT}} \right)^2 \right) R_{DSON\_BOT} \quad (24)$$

If the inductor ripple current is fairly small, the conduction losses can be simplified to:

$$P_{COND\_TOP} = (I_{OUT}^2 \times R_{DSON\_TOP} \times D) \quad (25)$$

$$P_{COND\_BOT} = (I_{OUT}^2 \times R_{DSON\_BOT} \times (1-D)) \quad (26)$$

$$P_{COND} = P_{COND\_TOP} + P_{COND\_BOT} \quad (27)$$

Switching losses are also associated with the internal FETs. They occur during the switch on and off transition periods, where voltages and currents overlap resulting in power loss. The simplest means to determine this loss is to empirically measuring the rise and fall times (10% to 90%) of the switch at the switch node.

Switching Power Loss is calculated as follows:

$$P_{SWR} = 1/2(V_{IN} \times I_{OUT} \times F_{SW} \times T_{RISE}) \quad (28)$$

$$P_{SWF} = 1/2(V_{IN} \times I_{OUT} \times F_{SW} \times T_{FALL}) \quad (29)$$

$$P_{SW} = P_{SWR} + P_{SWF} \quad (30)$$

Another loss is the power required for operation of the internal circuitry:

$$P_Q = I_Q \times V_{IN} \quad (31)$$

$I_Q$  is the quiescent operating current, and is typically around 8.4 mA ( $I_{QVINC} = 4.7$  mA +  $I_{QVIND} = 3.7$  mA) for the 550-kHz frequency option.

Due to Dead-Time-Control Logic in the converter, there is a small delay (~4 nsec) between the turn ON and OFF of the TOP and BOTTOM FET. During this time, the body diode of the BOTTOM FET is conducting with a voltage drop of  $V_{BDIODE}$  (~0.65 V). This allows the inductor current to circulate to the output, until the BOTTOM FET is turned ON and the inductor current passes through the FET. There is a small amount of power loss due to this body diode conducting and it can be calculated as follows:

$$P_{BDIODE} = 2 \times (V_{BDIODE} \times I_{OUT} \times F_{SW} \times T_{BDIODE}) \quad (32)$$

Typical Application power losses are:

$$P_{LOSS} = \Sigma P_{COND} + P_{SW} + P_{BDIODE} + P_{IND} + P_Q \quad (33)$$

$$P_{INTERNAL} = \Sigma P_{COND} + P_{SW} + P_{BDIODE} + P_Q \quad (34)$$

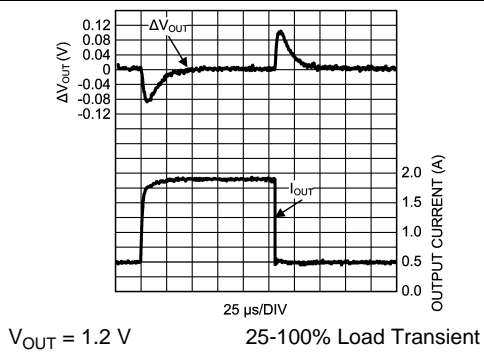


**Table 3. Power Loss Tabulation**

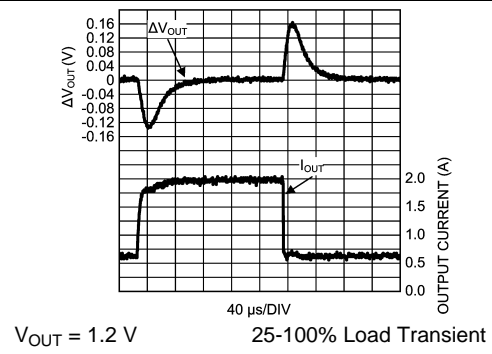
DESIGN PARAMETER	VALUE	DESIGN PARAMETER	VALUE
$V_{IN}$	5 V	$V_{OUT}$	1.2 V
$I_{OUT}$	2 A	$P_{OUT}$	2.4 W
$F_{SW}$	550 kHz		
$V_{BDIODE}$	0.65 V	$P_{BDIODE}$	5.7 mW
$I_Q$	8.4 mA	$P_Q$	42 mW
$T_{RISE}$	1.5 nsec	$P_{SWR}$	4.1 mW
$T_{FALL}$	1.5 nsec	$P_{SWF}$	4.1 mW
$R_{DSON\_TOP}$	75 m $\Omega$	$P_{COND\_TOP}$	81 mW
$R_{DSON\_BOT}$	55 m $\Omega$	$P_{COND\_BOT}$	167 mW
$IND_{DCR}$	20 m $\Omega$	$P_{IND}$	80 mW
D	0.262	$P_{LOSS}$	384 mW
$\eta$	86.2%	$P_{INTERNAL}$	304 mW

These calculations assume a junction temperature of 25°C. The  $R_{DSON}$  values are larger due to internal heating; therefore, the internal power loss ( $P_{INTERNAL}$ ) must be first calculated to estimate the rise in junction temperature.

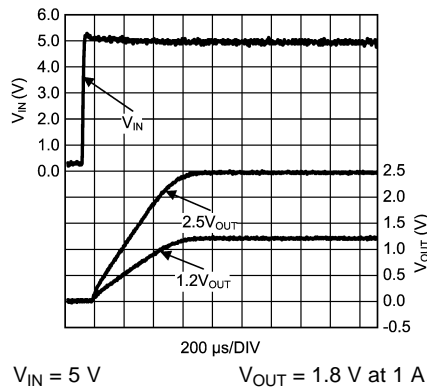
**8.2.1.3 Application Curves**



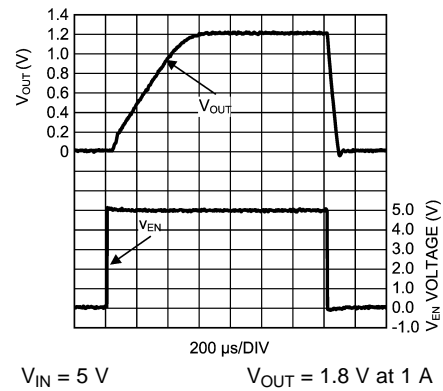
**Figure 38. Load Transient Response, X Option**



**Figure 39. Load Transient Response, Y Option**

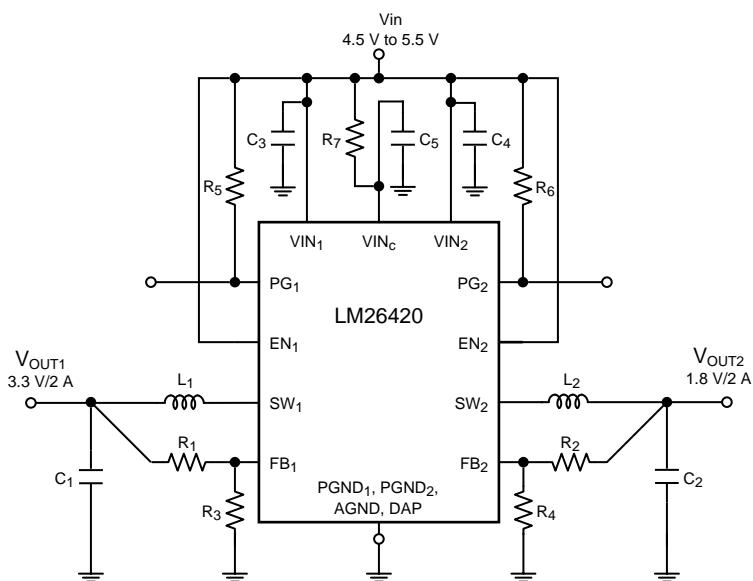


**Figure 40. Start-Up (Soft Start)**



**Figure 41. Enable - Disable**

## 8.2.2 LM26420X 2.2-MHz, 1.8-V Typical High-Efficiency Application Circuit



Copyright © 2016, Texas Instruments Incorporated

Figure 42. LM26420X (2.2 MHz):  $V_{IN} = 5\text{ V}$ ,  $V_{OUT1} = 3.3\text{ V}$  at 2 A and  $V_{OUT2} = 1.8\text{ V}$  at 2 A

### 8.2.2.1 Design Requirements

See [Design Requirements](#) above.

### 8.2.2.2 Detailed Design Procedure

Table 4. Bill Of Materials

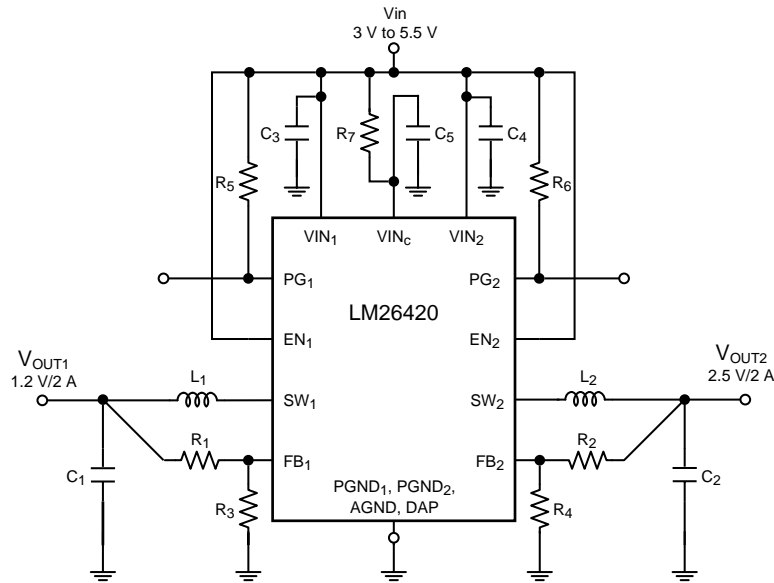
PART ID	PART VALUE	MANUFACTURER	PART NUMBER
U1	2-A Buck Regulator	TI	LM26420X
C3, C4	15 $\mu\text{F}$ , 6.3 V, 1206, X5R	TDK	C3216X5R0J156M
C1	22 $\mu\text{F}$ , 6.3 V, 1206, X5R	TDK	C3216X5R0J226M
C2	33 $\mu\text{F}$ , 6.3 V, 1206, X5R	TDK	C3216X5R0J336M
C5	0.47 $\mu\text{F}$ , 10 V, 0805, X7R	Vishay	VJ0805Y474KXQCW1BC
L1, L2	1.0 $\mu\text{H}$ , 7.9 A	TDK	RLF7030T-1R0M6R4
R3, R4	10.0 k $\Omega$ , 0603, 1%	Vishay	CRCW060310K0F
R2	12.7 k $\Omega$ , 0603, 1%	Vishay	CRCW060312K7F
R5, R6	49.9 k $\Omega$ , 0603, 1%	Vishay	CRCW060649K9F
R1	31.6 k $\Omega$ , 0603, 1%	Vishay	CRCW060331K6F
R7	4.99 $\Omega$ , 0603, 1%	Vishay	CRCW06034R99F

Also see [Detailed Design Procedure](#) above.

### 8.2.2.3 Application Curves

See [Application Curves](#) above.

### 8.2.3 LM26420X 2.2-MHz, 2.5-V Typical High-Efficiency Application Circuit



Copyright © 2016, Texas Instruments Incorporated

**Figure 43. LM26420X (2.2 MHz):  $V_{IN} = 5\text{ V}$ ,  $V_{OUT1} = 1.2\text{ V}$  at  $2\text{ A}$  and  $V_{OUT2} = 2.5\text{ V}$  at  $2\text{ A}$**

#### 8.2.3.1 Design Requirements

See [Design Requirements](#) above.

#### 8.2.3.2 Detailed Design Procedure

**Table 5. Bill Of Materials**

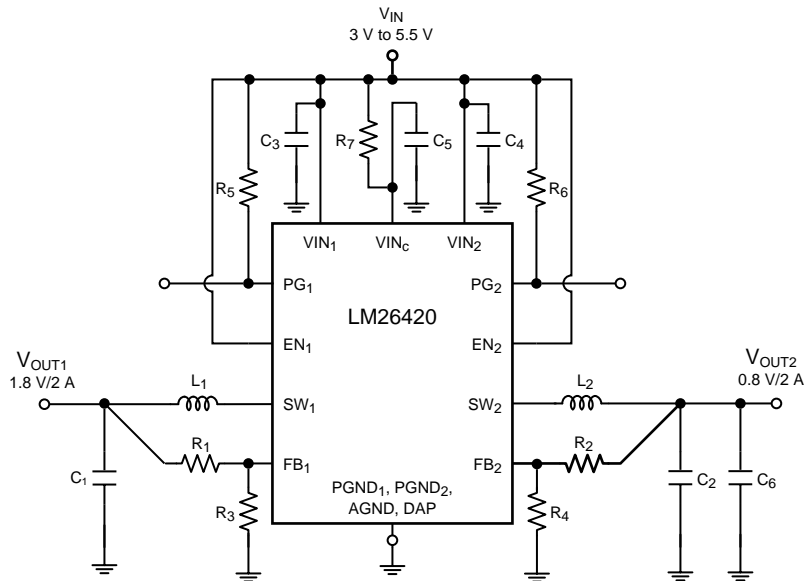
PART ID	PART VALUE	MANUFACTURER	PART NUMBER
U1	2-A buck regulator	TI	LM26420X
C3, C4	15 $\mu\text{F}$ , 6.3 V, 1206, X5R	TDK	C3216X5R0J156M
C1	33 $\mu\text{F}$ , 6.3 V, 1206, X5R	TDK	C3216X5R0J336M
C2	22 $\mu\text{F}$ , 6.3 V, 1206, X5R	TDK	C3216X5R0J226M
C5	0.47 $\mu\text{F}$ , 10 V, 0805, X7R	Vishay	VJ0805Y474KXQCW1BC
L1	1.0 $\mu\text{H}$ , 7.9A	TDK	RLF7030T-1R0M6R4
L2	1.5 $\mu\text{H}$ , 6.5A	TDK	RLF7030T-1R5M6R1
R3, R4	10.0 k $\Omega$ , 0603, 1%	Vishay	CRCW060310K0F
R1	4.99 k $\Omega$ , 0603, 1%	Vishay	CRCW06034K99F
R5, R6	49.9 k $\Omega$ , 0603, 1%	Vishay	CRCW060649K9F
R2	21.5 k $\Omega$ , 0603, 1%	Vishay	CRCW060321K5F
R7	4.99 $\Omega$ , 0603, 1%	Vishay	CRCW06034R99F

Also see [Detailed Design Procedure](#) above.

### 8.2.3.3 Application Curves

See [Application Curves](#) above.

### 8.2.4 LM26420Y 550 kHz, 0.8-V Typical High-Efficiency Application Circuit



Copyright © 2016, Texas Instruments Incorporated

Figure 44. LM26420Y (550 kHz):  $V_{IN} = 5\text{ V}$ ,  $V_{OUT1} = 1.8\text{ V}$  at  $2\text{ A}$  and  $V_{OUT2} = 0.8\text{ V}$  at  $2\text{ A}$

#### 8.2.4.1 Design Requirements

See [Design Requirements](#) above.

8.2.4.2 Detailed Design Procedure

Table 6. Bill Of Materials

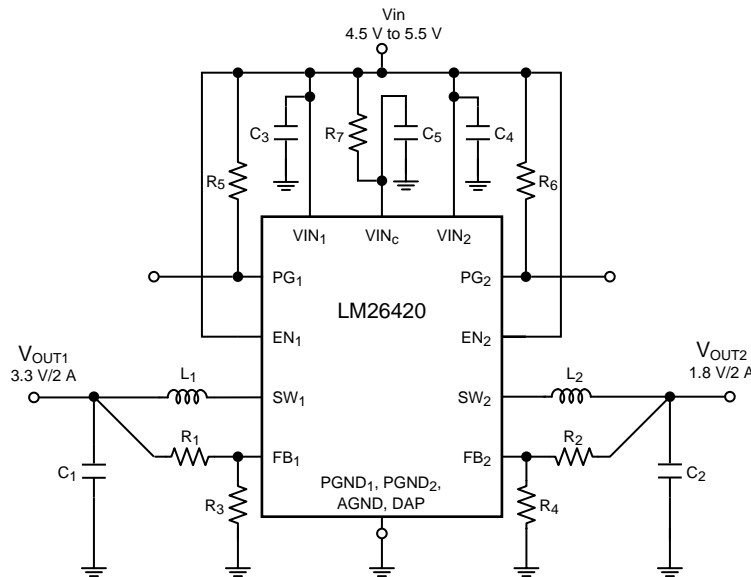
PART ID	PART VALUE	MANUFACTURER	PART NUMBER
U1	2-A buck regulator	TI	LM26420Y
C3, C4	22 $\mu$ F, 6.3 V, 1206, X5R	TDK	C3216X5R0J226M
C1, C2, C6	47 $\mu$ F, 6.3 V, 1206, X5R	TDK	C3216X5R0J476M
C5	0.47 $\mu$ F, 10 V, 0805, X7R	Vishay	VJ0805Y474KXQCW1BC
L1	5 $\mu$ H, 2.82 A	Coilcraft	MSS7341-502NL
L2	3.3 $\mu$ H, 3.28 A	Coilcraft	MSS7341-332NL
R3, R4	10.0 k $\Omega$ , 0603, 1%	Vishay	CRCW060310K0F
R5, R6	49.9 k $\Omega$ , 0603, 1%	Vishay	CRCW060649K9F
R1	12.7 k $\Omega$ , 0603, 1%	Vishay	CRCW060312K7F
R7, R2	4.99 $\Omega$ , 0603, 1%	Vishay	CRCW06034R99F

Also see [Detailed Design Procedure](#) above.

8.2.4.3 Application Curves

See [Application Curves](#) above.

8.2.5 LM26420Y 550-kHz, 1.8-V Typical High-Efficiency Application Circuit



Copyright © 2016, Texas Instruments Incorporated

Figure 45. LM26420Y (550 kHz):  $V_{IN} = 5\text{ V}$ ,  $V_{OUT1} = 3.3\text{ V}$  at 2 A and  $V_{OUT2} = 1.8\text{ V}$  at 2 A

8.2.5.1 Design Requirements

See [Design Requirements](#) above.

8.2.5.2 Detailed Design Procedure

Table 7. Bill Of Materials

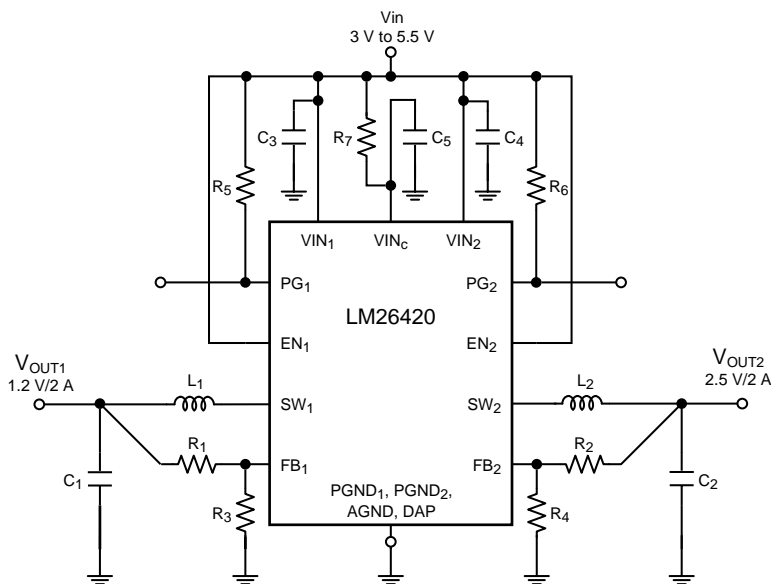
PART ID	PART VALUE	MANUFACTURER	PART NUMBER
U1	2-A buck regulator	TI	LM26420Y
C3, C4	22 $\mu$ F, 6.3 V, 1206, X5R	TDK	C3216X5R0J226M
C1, C2, C6	47 $\mu$ F, 6.3 V, 1206, X5R	TDK	C3216X5R0J476M
C5	0.47 $\mu$ F, 10 V, 0805, X7R	Vishay	VJ0805Y474KXQCW1BC
L1, L2	5 $\mu$ H, 2.82 A	Coilcraft	MSS7341-502NL
R3, R4	10 k $\Omega$ , 0603, 1%	Vishay	CRCW060310K0F
R2	12.7 k $\Omega$ , 0603, 1%	Vishay	CRCW060312K7F
R5, R6	49.9 k $\Omega$ , 0603, 1%	Vishay	CRCW060649K9F
R1	31.6 k $\Omega$ , 0603, 1%	Vishay	CRCW060331K6F
R7	4.99 $\Omega$ , 0603, 1%	Vishay	CRCW06034R99F

Also see [Detailed Design Procedure](#) above.

8.2.5.3 Application Curves

See [Application Curves](#) above.

8.2.6 LM26420Y 550-kHz, 2.5-V Typical High-Efficiency Application Circuit



Copyright © 2016, Texas Instruments Incorporated

Figure 46. LM26420Y (550 kHz):  $V_{IN} = 5\text{ V}$ ,  $V_{OUT1} = 1.2\text{ V}$  at 2 A and  $V_{OUT2} = 2.5\text{ V}$  at 2 A

8.2.6.1 Design Requirements

See [Design Requirements](#) above.

### 8.2.6.2 Detailed Design Procedure

**Table 8. Bill Of Materials**

PART ID	PART VALUE	MANUFACTURER	PART NUMBER
U1	2-A buck regulator	TI	LM26420Y
C3, C4	22 $\mu$ F, 6.3 V, 1206, X5R	TDK	C3216X5R0J226M
C1, C6, C7	33 $\mu$ F, 6.3 V, 1206, X5R	TDK	C3216X5R0J336M
C2	47 $\mu$ F, 6.3 V, 1206, X5R	TDK	C3216X5R0J476M
C5	0.47 $\mu$ F, 10 V, 0805, X7R	Vishay	VJ0805Y474KXQCW1BC
L1	3.3 $\mu$ H, 3.28 A	Coilcraft	MSS7341-332NL
L2	5 $\mu$ H, 2.82 A	Coilcraft	MSS7341-502NL
R3, R4	10 k $\Omega$ , 0603, 1%	Vishay	CRCW060310K0F
R1	4.99 k $\Omega$ , 0603, 1%	Vishay	CRCW06034K99F
R5, R6	49.9 k $\Omega$ , 0603, 1%	Vishay	CRCW060649K9F
R2	21.5 k $\Omega$ , 0603, 1%	Vishay	CRCW060321K5F
R7	4.99 $\Omega$ , 0603, 1%	Vishay	CRCW06034R99F

Also see [Detailed Design Procedure](#) above.

### 8.2.6.3 Application Curves

See [Application Curves](#) above.

## 9 Power Supply Recommendations

The LM26420 is designed to operate from an input voltage supply range between 3 V and 5.5 V. This input supply must be well regulated and able to withstand maximum input current and maintain a stable voltage. The resistance of the input supply rail must be low enough that an input current transient does not cause a high enough drop at the LM26420 supply voltage that can cause a false UVLO fault triggering and system reset. If the input supply is located more than a few inches from the LM26420, additional bulk capacitance may be required in addition to the ceramic bypass capacitors. The amount of bulk capacitance is not critical, but a 47- $\mu$ F or 100- $\mu$ F electrolytic capacitor is a typical choice.

## 10 Layout

### 10.1 Layout Guidelines

When planning layout there are a few things to consider when trying to achieve a clean, regulated output. The most important consideration is the close coupling of the GND connections of the input capacitor and the PGND pin. These ground ends must be close to one another and be connected to the GND plane with at least two through-holes. Place these components as close to the device as possible. Next in importance is the location of the GND connection of the output capacitor, which must be near the GND connections of VIND and PGND. There must be a continuous ground plane on the bottom layer of a two-layer board except under the switching node island. The FB pin is a high impedance node, and care must be taken to make the FB trace short to avoid noise pickup and inaccurate regulation. The feedback resistors must be placed as close to the device as possible, with the GND of R1 placed as close to the GND of the device as possible. The VOUT trace to R2 must be routed away from the inductor and any other traces that are switching. High AC currents flow through the VIN, SW, and VOUT traces, so they must be as short and wide as possible. However, making the traces wide increases radiated noise, so the designer must make this trade-off. Radiated noise can be decreased by choosing a shielded inductor. The remaining components must also be placed as close as possible to the device. See [AN-1229 SIMPLE SWITCHER® PCB Layout Guidelines](#) for further considerations, and the LM26420 demo board as an example of a four-layer layout.



## Layout Guidelines (continued)

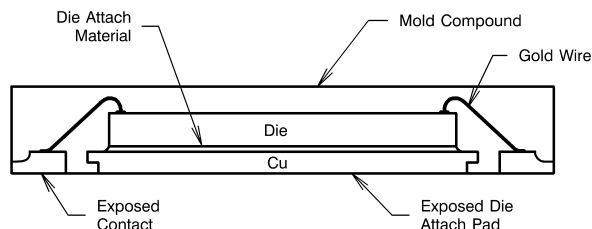


Figure 47. Internal Connection

For certain high power applications, the PCB land may be modified to a *dog bone* shape (see Figure 48). By increasing the size of ground plane, and adding thermal vias, the  $R_{\theta JA}$  for the application can be reduced.

## 10.2 Layout Example

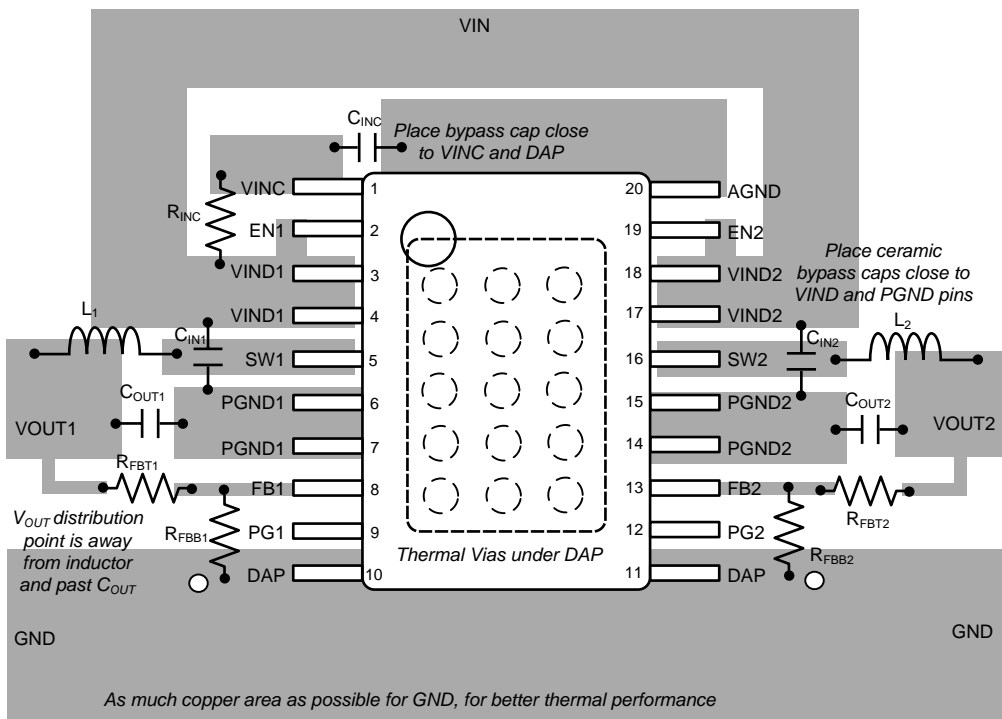


Figure 48. Typical Layout For DC/DC Converter

## 10.3 Thermal Considerations

$T_J$  = Chip junction temperature

$T_A$  = Ambient temperature

$R_{\theta JC}$  = Thermal resistance from chip junction to device case

$R_{\theta JA}$  = Thermal resistance from chip junction to ambient air

Heat in the LM26420 due to internal power dissipation is removed through conduction and/or convection.

Conduction: Heat transfer occurs through cross sectional areas of material. Depending on the material, the transfer of heat can be considered to have poor to good thermal conductivity properties (insulator vs conductor).

Heat Transfer goes as:

## Thermal Considerations (continued)

Silicon → package → lead frame → PCB

Convection: Heat transfer is by means of airflow. This could be from a fan or natural convection. Natural convection occurs when air currents rise from the hot device to cooler air.

Thermal impedance is defined as:

$$R_{\theta} = \frac{\Delta T}{\text{Power}} \quad (35)$$

Thermal impedance from the silicon junction to the ambient air is defined as:

$$R_{\theta JA} = \frac{T_J - T_A}{P_{\text{INTERNAL}}} \quad (36)$$

The PCB size, weight of copper used to route traces and ground plane, and number of layers within the PCB can greatly affect  $R_{\theta JA}$ . The type and number of thermal vias can also make a large difference in the thermal impedance. Thermal vias are necessary in most applications. They conduct heat from the surface of the PCB to the ground plane. Five to eight thermal vias must be placed under the exposed pad to the ground plane if the WQFN package is used. Up to 12 thermal vias must be used in the HTSSOP-20 package for optimum heat transfer from the device to the ground plane.

Thermal impedance also depends on the thermal properties of the application's operating conditions ( $V_{IN}$ ,  $V_{OUT}$ ,  $I_{OUT}$ , etc.), and the surrounding circuitry.

### 10.3.1 Method 1: Silicon Junction Temperature Determination

To accurately measure the silicon temperature for a given application, two methods can be used. The first method requires the user to know the thermal impedance of the silicon junction to top case temperature.

Some clarification needs to be made before we go any further.

$R_{\theta JC}$  is the thermal impedance from silicon junction to the exposed pad.

$R_{\theta JT}$  is the thermal impedance from top case to the silicon junction.

In this data sheet  $R_{\theta JT}$  is used so that it allows the user to measure top case temperature with a small thermocouple attached to the top case.

$R_{\theta JT}$  is approximately 20°C/W for the 16-pin WQFN package with the exposed pad. Knowing the internal dissipation from the efficiency calculation given previously, and the case temperature, which can be empirically measured on the bench we have:

$$R_{\theta JT} = \frac{T_J - T_T}{P_{\text{INTERNAL}}} \quad (37)$$

Therefore:

$$T_J = (R_{\theta JT} \times P_{\text{INTERNAL}}) + T_C \quad (38)$$

From the previous example:

$$T_J = 20^\circ\text{C/W} \times 0.304\text{W} + T_C \quad (39)$$

### 10.3.2 Thermal Shutdown Temperature Determination

The second method, although more complicated, can give a very accurate silicon junction temperature.

The first step is to determine  $R_{\theta JA}$  of the application. The LM26420 has over-temperature protection circuitry. When the silicon temperature reaches 165°C, the device stops switching. The protection circuitry has a hysteresis of about 15°C. Once the silicon junction temperature has decreased to approximately 150°C, the device starts to switch again. Knowing this, the  $R_{\theta JA}$  for any application can be characterized during the early stages of the design one may calculate the  $R_{\theta JA}$  by placing the PCB circuit into a thermal chamber. Raise the ambient temperature in the given working application until the circuit enters thermal shutdown. If the SW pin is monitored, it is obvious when the internal FETs stop switching, indicating a junction temperature of 165°C. Knowing the internal power dissipation from the above methods, the junction temperature, and the ambient temperature  $R_{\theta JA}$  can be determined.

## Thermal Considerations (continued)

$$R_{\theta JA} = \frac{165^{\circ} - T_A}{P_{INTERNAL}} \quad (40)$$

Once this is determined, the maximum ambient temperature allowed for a desired junction temperature can be found.

An example of calculating  $R_{\theta JA}$  for an application using the LM26420 WQFN demonstration board is shown below.

The four layer PCB is constructed using FR4 with 1 oz copper traces. The copper ground plane is on the bottom layer. The ground plane is accessed by eight vias. The board measures 3 cm × 3 cm. It was placed in an oven with no forced airflow. The ambient temperature was raised to 152°C, and at that temperature, the device went into thermal shutdown.

From the previous example:

$$P_{INTERNAL} = 304 \text{ mW} \quad (41)$$

$$R_{\theta JA} = \frac{165^{\circ}\text{C} - 152^{\circ}\text{C}}{304 \text{ mW}} = 42.8^{\circ} \text{ C/W} \quad (42)$$

If the junction temperature was to be kept below 125°C, then the ambient temperature could not go above 112°C.

$$T_J - (R_{\theta JA} \times P_{INTERNAL}) = T_A \quad (43)$$

$$125^{\circ}\text{C} - (42.8^{\circ}\text{C/W} \times 304 \text{ mW}) = 112.0^{\circ}\text{C} \quad (44)$$

## 11 Device and Documentation Support

### 11.1 Device Support

#### 11.1.1 Third-Party Products Disclaimer

TI'S PUBLICATION OF INFORMATION REGARDING THIRD-PARTY PRODUCTS OR SERVICES DOES NOT CONSTITUTE AN ENDORSEMENT REGARDING THE SUITABILITY OF SUCH PRODUCTS OR SERVICES OR A WARRANTY, REPRESENTATION OR ENDORSEMENT OF SUCH PRODUCTS OR SERVICES, EITHER ALONE OR IN COMBINATION WITH ANY TI PRODUCT OR SERVICE.

#### 11.1.2 Custom Design With WEBENCH® Tools

[Click here](#) to create a custom design using the LM26420 device with the WEBENCH® Power Designer.

1. Start by entering the input voltage ( $V_{IN}$ ), output voltage ( $V_{OUT}$ ), and output current ( $I_{OUT}$ ) requirements.
2. Optimize the design for key parameters such as efficiency, footprint, and cost using the optimizer dial.
3. Compare the generated design with other possible solutions from Texas Instruments.

The WEBENCH Power Designer provides a customized schematic along with a list of materials with real-time pricing and component availability.

In most cases, these actions are available:

- Run electrical simulations to see important waveforms and circuit performance
- Run thermal simulations to understand board thermal performance
- Export customized schematic and layout into popular CAD formats
- Print PDF reports for the design, and share the design with colleagues

Get more information about WEBENCH tools at [www.ti.com/WEBENCH](http://www.ti.com/WEBENCH).

### 11.2 Documentation Support

#### 11.2.1 Related Documentation

*AN-1229 SIMPLE SWITCHER® PCB Layout Guidelines (SNVA054)*

### 11.3 Receiving Notification of Documentation Updates

To receive notification of documentation updates, navigate to the device product folder on ti.com. In the upper right corner, click on *Alert me* to register and receive a weekly digest of any product information that has changed. For change details, review the revision history included in any revised document.

### 11.4 Community Resources

The following links connect to TI community resources. Linked contents are provided "AS IS" by the respective contributors. They do not constitute TI specifications and do not necessarily reflect TI's views; see TI's [Terms of Use](#).

**TI E2E™ Online Community** *TI's Engineer-to-Engineer (E2E) Community*. Created to foster collaboration among engineers. At [e2e.ti.com](http://e2e.ti.com), you can ask questions, share knowledge, explore ideas and help solve problems with fellow engineers.

**Design Support** *TI's Design Support* Quickly find helpful E2E forums along with design support tools and contact information for technical support.

### 11.5 Trademarks

E2E is a trademark of Texas Instruments.

WEBENCH is a registered trademark of Texas Instruments.

All other trademarks are the property of their respective owners.

## 11.6 Electrostatic Discharge Caution



These devices have limited built-in ESD protection. The leads should be shorted together or the device placed in conductive foam during storage or handling to prevent electrostatic damage to the MOS gates.

## 11.7 Glossary

[SLYZ022](#) — *TI Glossary*.

This glossary lists and explains terms, acronyms, and definitions.

## 12 Mechanical, Packaging, and Orderable Information

The following pages include mechanical, packaging, and orderable information. This information is the most current data available for the designated devices. This data is subject to change without notice and revision of this document. For browser-based versions of this data sheet, refer to the left-hand navigation.

**PACKAGING INFORMATION**

Orderable Device	Status (1)	Package Type	Package Drawing	Pins	Package Qty	Eco Plan (2)	Lead/Ball Finish (6)	MSL Peak Temp (3)	Op Temp (°C)	Device Marking (4/5)	Samples
LM26420XMH/NOPB	ACTIVE	HTSSOP	PWP	20	73	Green (RoHS & no Sb/Br)	CU SN	Level-1-260C-UNLIM	-40 to 125	LM26420 XMH	<a href="#">Samples</a>
LM26420XMHX/NOPB	ACTIVE	HTSSOP	PWP	20	2500	Green (RoHS & no Sb/Br)	CU SN	Level-1-260C-UNLIM	-40 to 125	LM26420 XMH	<a href="#">Samples</a>
LM26420XSQ/NOPB	ACTIVE	WQFN	RUM	16	1000	Green (RoHS & no Sb/Br)	CU SN	Level-3-260C-168 HR	-40 to 125	L26420X	<a href="#">Samples</a>
LM26420XSQX/NOPB	ACTIVE	WQFN	RUM	16	4500	Green (RoHS & no Sb/Br)	CU SN	Level-3-260C-168 HR	-40 to 125	L26420X	<a href="#">Samples</a>
LM26420YMH/NOPB	ACTIVE	HTSSOP	PWP	20	73	Green (RoHS & no Sb/Br)	CU SN	Level-1-260C-UNLIM	-40 to 125	LM26420 YMH	<a href="#">Samples</a>
LM26420YMHX/NOPB	ACTIVE	HTSSOP	PWP	20	2500	Green (RoHS & no Sb/Br)	CU SN	Level-1-260C-UNLIM	-40 to 125	LM26420 YMH	<a href="#">Samples</a>
LM26420YSQ/NOPB	ACTIVE	WQFN	RUM	16	1000	Green (RoHS & no Sb/Br)	CU SN	Level-3-260C-168 HR	-40 to 125	L26420Y	<a href="#">Samples</a>
LM26420YSQX/NOPB	ACTIVE	WQFN	RUM	16	4500	Green (RoHS & no Sb/Br)	CU SN	Level-3-260C-168 HR	-40 to 125	L26420Y	<a href="#">Samples</a>

(1) The marketing status values are defined as follows:

**ACTIVE:** Product device recommended for new designs.

**LIFEBUY:** TI has announced that the device will be discontinued, and a lifetime-buy period is in effect.

**NRND:** Not recommended for new designs. Device is in production to support existing customers, but TI does not recommend using this part in a new design.

**PREVIEW:** Device has been announced but is not in production. Samples may or may not be available.

**OBSOLETE:** TI has discontinued the production of the device.

(2) **RoHS:** TI defines "RoHS" to mean semiconductor products that are compliant with the current EU RoHS requirements for all 10 RoHS substances, including the requirement that RoHS substance do not exceed 0.1% by weight in homogeneous materials. Where designed to be soldered at high temperatures, "RoHS" products are suitable for use in specified lead-free processes. TI may reference these types of products as "Pb-Free".

**RoHS Exempt:** TI defines "RoHS Exempt" to mean products that contain lead but are compliant with EU RoHS pursuant to a specific EU RoHS exemption.

**Green:** TI defines "Green" to mean the content of Chlorine (Cl) and Bromine (Br) based flame retardants meet JS709B low halogen requirements of <=100ppm threshold. Antimony trioxide based flame retardants must also meet the <=1000ppm threshold requirement.

(3) MSL, Peak Temp. - The Moisture Sensitivity Level rating according to the JEDEC industry standard classifications, and peak solder temperature.

(4) There may be additional marking, which relates to the logo, the lot trace code information, or the environmental category on the device.

(5) Multiple Device Markings will be inside parentheses. Only one Device Marking contained in parentheses and separated by a "-" will appear on a device. If a line is indented then it is a continuation of the previous line and the two combined represent the entire Device Marking for that device.

(6) Lead/Ball Finish - Orderable Devices may have multiple material finish options. Finish options are separated by a vertical ruled line. Lead/Ball Finish values may wrap to two lines if the finish value exceeds the maximum column width.

**Important Information and Disclaimer:**The information provided on this page represents TI's knowledge and belief as of the date that it is provided. TI bases its knowledge and belief on information provided by third parties, and makes no representation or warranty as to the accuracy of such information. Efforts are underway to better integrate information from third parties. TI has taken and continues to take reasonable steps to provide representative and accurate information but may not have conducted destructive testing or chemical analysis on incoming materials and chemicals. TI and TI suppliers consider certain information to be proprietary, and thus CAS numbers and other limited information may not be available for release.

In no event shall TI's liability arising out of such information exceed the total purchase price of the TI part(s) at issue in this document sold by TI to Customer on an annual basis.

**OTHER QUALIFIED VERSIONS OF LM26420 :**

- Automotive: [LM26420-Q1](#)

NOTE: Qualified Version Definitions:

- Automotive - Q100 devices qualified for high-reliability automotive applications targeting zero defects

**TAPE AND REEL INFORMATION**

**QUADRANT ASSIGNMENTS FOR PIN 1 ORIENTATION IN TAPE**


\*All dimensions are nominal

Device	Package Type	Package Drawing	Pins	SPQ	Reel Diameter (mm)	Reel Width W1 (mm)	A0 (mm)	B0 (mm)	K0 (mm)	P1 (mm)	W (mm)	Pin1 Quadrant
LM26420MHX/NOPB	HTSSOP	PWP	20	2500	330.0	16.4	6.95	7.1	1.6	8.0	16.0	Q1
LM26420XSQ/NOPB	WQFN	RUM	16	1000	178.0	12.4	4.3	4.3	1.3	8.0	12.0	Q1
LM26420XSQX/NOPB	WQFN	RUM	16	4500	330.0	12.4	4.3	4.3	1.3	8.0	12.0	Q1
LM26420YMHX/NOPB	HTSSOP	PWP	20	2500	330.0	16.4	6.95	7.1	1.6	8.0	16.0	Q1
LM26420YSQ/NOPB	WQFN	RUM	16	1000	178.0	12.4	4.3	4.3	1.3	8.0	12.0	Q1
LM26420YSQX/NOPB	WQFN	RUM	16	4500	330.0	12.4	4.3	4.3	1.3	8.0	12.0	Q1

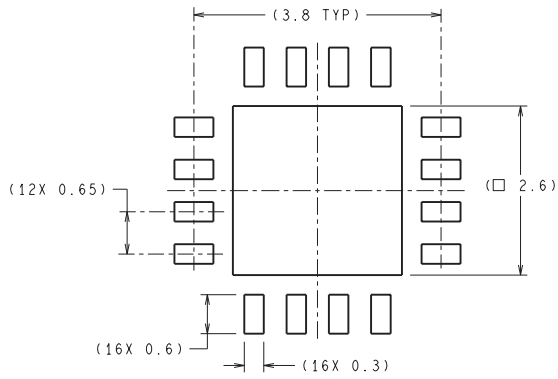


**TAPE AND REEL BOX DIMENSIONS**


\*All dimensions are nominal

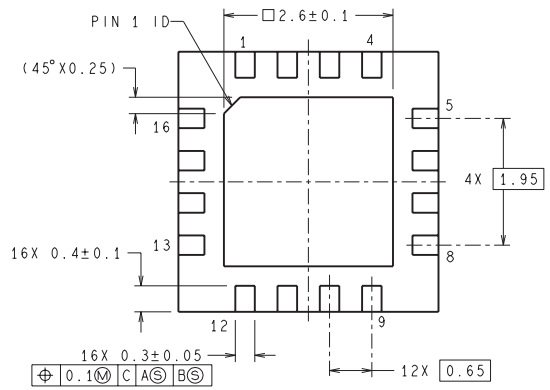
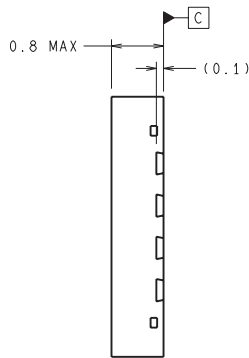
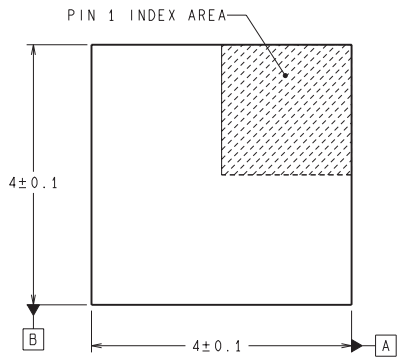
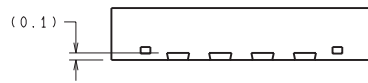
Device	Package Type	Package Drawing	Pins	SPQ	Length (mm)	Width (mm)	Height (mm)
LM26420XMHX/NOPB	HTSSOP	PWP	20	2500	367.0	367.0	35.0
LM26420XSQ/NOPB	WQFN	RUM	16	1000	210.0	185.0	35.0
LM26420XSQX/NOPB	WQFN	RUM	16	4500	367.0	367.0	35.0
LM26420YMHX/NOPB	HTSSOP	PWP	20	2500	367.0	367.0	35.0
LM26420YSQ/NOPB	WQFN	RUM	16	1000	210.0	185.0	35.0
LM26420YSQX/NOPB	WQFN	RUM	16	4500	367.0	367.0	35.0

RUM0016A



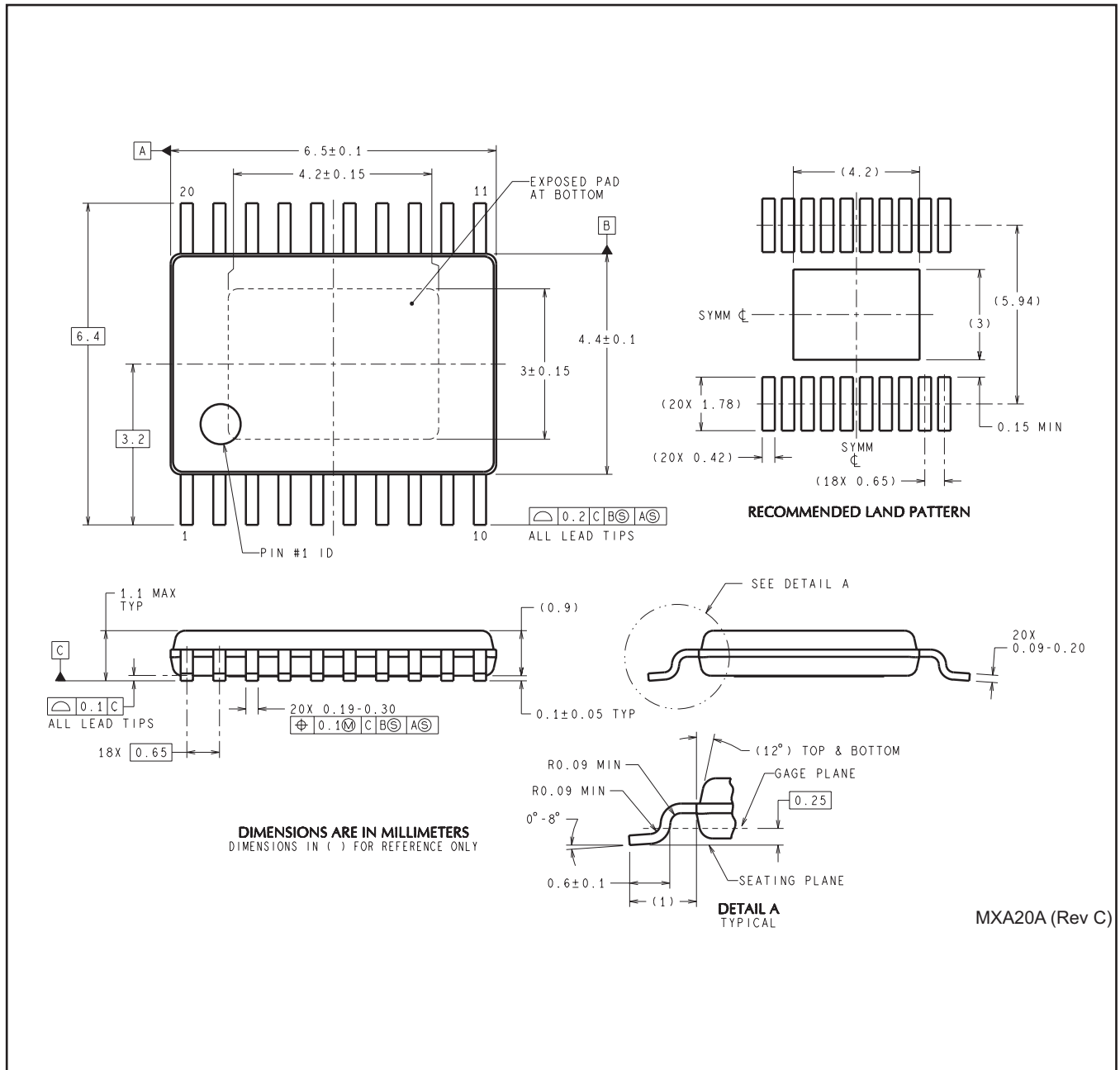
DIMENSIONS ARE IN MILLIMETERS  
DIMENSIONS IN ( ) FOR REFERENCE ONLY

RECOMMENDED LAND PATTERN



SQB16A (Rev A)

PWP0020A



## IMPORTANT NOTICE

Texas Instruments Incorporated (TI) reserves the right to make corrections, enhancements, improvements and other changes to its semiconductor products and services per JESD46, latest issue, and to discontinue any product or service per JESD48, latest issue. Buyers should obtain the latest relevant information before placing orders and should verify that such information is current and complete.

TI's published terms of sale for semiconductor products (<http://www.ti.com/sc/docs/stdterms.htm>) apply to the sale of packaged integrated circuit products that TI has qualified and released to market. Additional terms may apply to the use or sale of other types of TI products and services.

Reproduction of significant portions of TI information in TI data sheets is permissible only if reproduction is without alteration and is accompanied by all associated warranties, conditions, limitations, and notices. TI is not responsible or liable for such reproduced documentation. Information of third parties may be subject to additional restrictions. Resale of TI products or services with statements different from or beyond the parameters stated by TI for that product or service voids all express and any implied warranties for the associated TI product or service and is an unfair and deceptive business practice. TI is not responsible or liable for any such statements.

Buyers and others who are developing systems that incorporate TI products (collectively, "Designers") understand and agree that Designers remain responsible for using their independent analysis, evaluation and judgment in designing their applications and that Designers have full and exclusive responsibility to assure the safety of Designers' applications and compliance of their applications (and of all TI products used in or for Designers' applications) with all applicable regulations, laws and other applicable requirements. Designer represents that, with respect to their applications, Designer has all the necessary expertise to create and implement safeguards that (1) anticipate dangerous consequences of failures, (2) monitor failures and their consequences, and (3) lessen the likelihood of failures that might cause harm and take appropriate actions. Designer agrees that prior to using or distributing any applications that include TI products, Designer will thoroughly test such applications and the functionality of such TI products as used in such applications.

TI's provision of technical, application or other design advice, quality characterization, reliability data or other services or information, including, but not limited to, reference designs and materials relating to evaluation modules, (collectively, "TI Resources") are intended to assist designers who are developing applications that incorporate TI products; by downloading, accessing or using TI Resources in any way, Designer (individually or, if Designer is acting on behalf of a company, Designer's company) agrees to use any particular TI Resource solely for this purpose and subject to the terms of this Notice.

TI's provision of TI Resources does not expand or otherwise alter TI's applicable published warranties or warranty disclaimers for TI products, and no additional obligations or liabilities arise from TI providing such TI Resources. TI reserves the right to make corrections, enhancements, improvements and other changes to its TI Resources. TI has not conducted any testing other than that specifically described in the published documentation for a particular TI Resource.

Designer is authorized to use, copy and modify any individual TI Resource only in connection with the development of applications that include the TI product(s) identified in such TI Resource. NO OTHER LICENSE, EXPRESS OR IMPLIED, BY ESTOPPEL OR OTHERWISE TO ANY OTHER TI INTELLECTUAL PROPERTY RIGHT, AND NO LICENSE TO ANY TECHNOLOGY OR INTELLECTUAL PROPERTY RIGHT OF TI OR ANY THIRD PARTY IS GRANTED HEREIN, including but not limited to any patent right, copyright, mask work right, or other intellectual property right relating to any combination, machine, or process in which TI products or services are used. Information regarding or referencing third-party products or services does not constitute a license to use such products or services, or a warranty or endorsement thereof. Use of TI Resources may require a license from a third party under the patents or other intellectual property of the third party, or a license from TI under the patents or other intellectual property of TI.

TI RESOURCES ARE PROVIDED "AS IS" AND WITH ALL FAULTS. TI DISCLAIMS ALL OTHER WARRANTIES OR REPRESENTATIONS, EXPRESS OR IMPLIED, REGARDING RESOURCES OR USE THEREOF, INCLUDING BUT NOT LIMITED TO ACCURACY OR COMPLETENESS, TITLE, ANY EPIDEMIC FAILURE WARRANTY AND ANY IMPLIED WARRANTIES OF MERCHANTABILITY, FITNESS FOR A PARTICULAR PURPOSE, AND NON-INFRINGEMENT OF ANY THIRD PARTY INTELLECTUAL PROPERTY RIGHTS. TI SHALL NOT BE LIABLE FOR AND SHALL NOT DEFEND OR INDEMNIFY DESIGNER AGAINST ANY CLAIM, INCLUDING BUT NOT LIMITED TO ANY INFRINGEMENT CLAIM THAT RELATES TO OR IS BASED ON ANY COMBINATION OF PRODUCTS EVEN IF DESCRIBED IN TI RESOURCES OR OTHERWISE. IN NO EVENT SHALL TI BE LIABLE FOR ANY ACTUAL, DIRECT, SPECIAL, COLLATERAL, INDIRECT, PUNITIVE, INCIDENTAL, CONSEQUENTIAL OR EXEMPLARY DAMAGES IN CONNECTION WITH OR ARISING OUT OF TI RESOURCES OR USE THEREOF, AND REGARDLESS OF WHETHER TI HAS BEEN ADVISED OF THE POSSIBILITY OF SUCH DAMAGES.

Unless TI has explicitly designated an individual product as meeting the requirements of a particular industry standard (e.g., ISO/TS 16949 and ISO 26262), TI is not responsible for any failure to meet such industry standard requirements.

Where TI specifically promotes products as facilitating functional safety or as compliant with industry functional safety standards, such products are intended to help enable customers to design and create their own applications that meet applicable functional safety standards and requirements. Using products in an application does not by itself establish any safety features in the application. Designers must ensure compliance with safety-related requirements and standards applicable to their applications. Designer may not use any TI products in life-critical medical equipment unless authorized officers of the parties have executed a special contract specifically governing such use. Life-critical medical equipment is medical equipment where failure of such equipment would cause serious bodily injury or death (e.g., life support, pacemakers, defibrillators, heart pumps, neurostimulators, and implantables). Such equipment includes, without limitation, all medical devices identified by the U.S. Food and Drug Administration as Class III devices and equivalent classifications outside the U.S.

TI may expressly designate certain products as completing a particular qualification (e.g., Q100, Military Grade, or Enhanced Product). Designers agree that it has the necessary expertise to select the product with the appropriate qualification designation for their applications and that proper product selection is at Designers' own risk. Designers are solely responsible for compliance with all legal and regulatory requirements in connection with such selection.

Designer will fully indemnify TI and its representatives against any damages, costs, losses, and/or liabilities arising out of Designer's non-compliance with the terms and provisions of this Notice.