

Features

- Reference Voltage Tolerance at 25°C
 - 0.5% (B Grade)
 - 1% (A Grade)
- Operation from –40°C to 125°C
- 0.2-Ω Typical Output Impedance
- Sink Current Capability: 1 mA to 80 mA
- Adjustable Output Voltage: V_{REF} to 36V

Applications

- Power
- Led Lighting
- Current Sensing
- Instrumentation
- Industry

Description

The TPR431 and TPR432 are adjustable shunt voltage references with guaranteed temperature stability over the operating temperature range. The device temperature range is extended from –40 °C up to +125 °C. The output voltage can be set to any value between 2.5 and 36 V with two external resistors. The TPR431 operates with a wide current range from 1 to 80 mA with a typical dynamic impedance of 0.2 Ω.

Pin Configuration

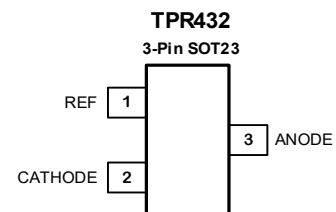
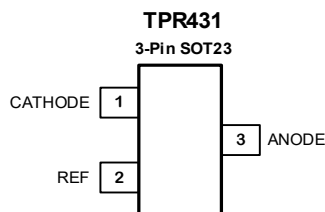

Functional Block Diagram

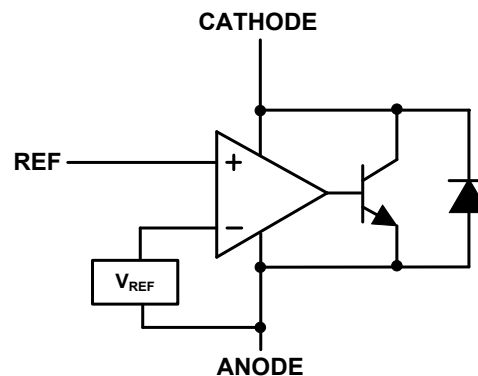

Product Family Table

Order Number	Grade	Voltage Tolerance	Package
TPR431B-S3TR	B	0.5%	SOT23G-3
TPR431A-S3TR	A	1%	SOT23G-3
TPR432B-S3TR	B	0.5%	SOT23G-3
TPR432A-S3TR	A	1%	SOT23G-3

Table of Contents

Features	1
Applications	1
Description	1
Pin Configuration	1
Functional Block Diagram	1
Product Family Table	2
Revision History	4
Specifications	5
Absolute Maximum Ratings.....	5
ESD, Electrostatic Discharge Protection	5
Recommended Operating Conditions	5
Thermal Information	5
Electrical Characteristics	6
Typical Performance Characteristics	7
Tape and Reel Information	8
Package Outline Dimensions	9
SOT23G-3	9
Order Information	10

Revision History

Date	Revision	Notes
2021-06-12	Rev A.0	Initial Version.
2021-11-01	Rev.A.1	1. Add New Product TPR432. 2. Add Tape and Reel Information.

Specifications

Absolute Maximum Ratings

Parameter		Min	Max	Unit
Cathode Voltage			37	V
Continuous Cathode Current		-100	150	mA
Reference Input Current			10	mA
T _J	Maximum Junction Temperature	-40	150	°C
T _A	Operating Temperature Range	-40	125	°C
T _{STG}	Storage Temperature Range	-65	150	°C
T _L	Lead Temperature (Soldering 10 sec)		260	°C

(1) Stresses beyond those listed under Absolute Maximum Ratings may cause permanent damage to the device. Exposure to any Absolute Maximum Rating condition for extended periods may affect device reliability and lifetime.

ESD, Electrostatic Discharge Protection

Symbol	Parameter	Condition	Minimum Level	Unit
HBM	Human Body Model ESD	ANSI/ESDA/JEDEC JS-001 ⁽¹⁾	2000	V
CDM	Charged Device Model ESD	ANSI/ESDA/JEDEC JS-002 ⁽²⁾	1000	V

(1) JEDEC document JEP155 states that 500-V HBM allows safe manufacturing with a standard ESD control process.

(2) JEDEC document JEP157 states that 250-V CDM allows safe manufacturing with a standard ESD control process.

Recommended Operating Conditions

Parameter		Min	Max	Unit
V _{KA}	Cathode Voltage	V _{REF}	36	V
I _{KA}	Cathode Current	1	80	mA

Thermal Information

Package Type	θ _{JA}	θ _{JC}	Unit
SOT23G-3	400	120	°C/W

Electrical Characteristics

 All test conditions: $T_A = +25^\circ\text{C}$, unless otherwise noted.

Symbol	Parameter	Conditions	Min	Typ	Max	Unit
V_{REF}	Reference voltage	$V_{KA} = V_{REF}$, $I_{KA} = 10\text{ mA}$, A grade, 1% Initial Accuracy	2.470	2.495	2.520	V
		$V_{KA} = V_{REF}$, $I_{KA} = 10\text{ mA}$, B grade, 0.5% Initial Accuracy	2.483	2.495	2.507	V
V_{DEV}	Reference input voltage deviation over temperature range	$V_{KA} = V_{REF}$, $I_{KA} = 10\text{ mA}$, $T_A = -40\text{ to }85^\circ\text{C}$		5	15	mV
		$V_{KA} = V_{REF}$, $I_{KA} = 10\text{ mA}$, $T_A = -40\text{ to }125^\circ\text{C}$		11	30	mV
$\frac{\Delta V_{REF}}{\Delta V_{KA}}$	Ratio of the change in reference voltage to the change in cathode voltage	$I_{KA} = 10\text{ mA}$, $V_{KA} = 10\text{ V to }V_{REF}$	-1.5	0.3	1.5	mV/V
		$I_{KA} = 10\text{ mA}$, $V_{KA} = 36\text{ V to }10\text{ V}$	-1	0.1	1	mV/V
I_{REF}	Reference input current	$I_{KA} = 10\text{ mA}$, $R1 = 10\text{ K}$, $R2\text{ Open}$		1	4	μA
ΔI_{REF}	I_{REF} deviation over full temperature range	$I_{KA} = 10\text{ mA}$, $R1 = 10\text{ K}$, $R2\text{ Open}$, $T_A = -40\text{ to }125^\circ\text{C}$		0.1	1	μA
$I_{KA(MIN)}$	Minimum cathode current for regulation	$V_{KA} = V_{REF}$		0.4	1	mA
$I_{KA(OFF)}$	Off-state current	$V_{KA} = 36\text{ V}$, $V_{REF} = 0\text{ V}$		0.2		μA
$ Z_{KA} $	Dynamic output impedance	$V_{KA} = V_{REF}$, $f \leq 1\text{ kHz}$, $I_{KA} = 1\text{ mA to }80\text{ mA}$		0.2		Ω

Typical Performance Characteristics

All test conditions: $T_A = +25^\circ\text{C}$, unless otherwise noted.

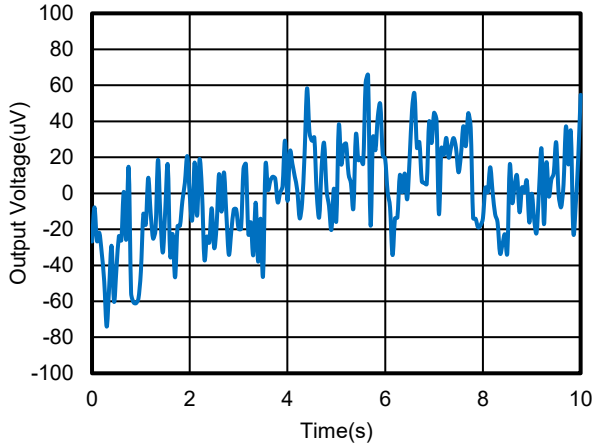

Figure 1. 0.1 to 10Hz Output Voltage Noise

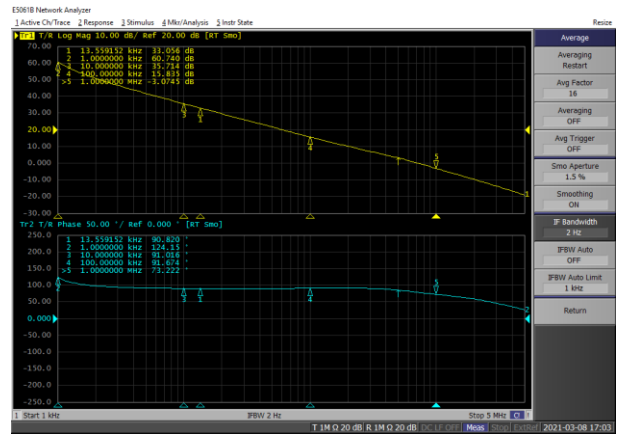

Figure 2. Gain and Phase vs. Frequency

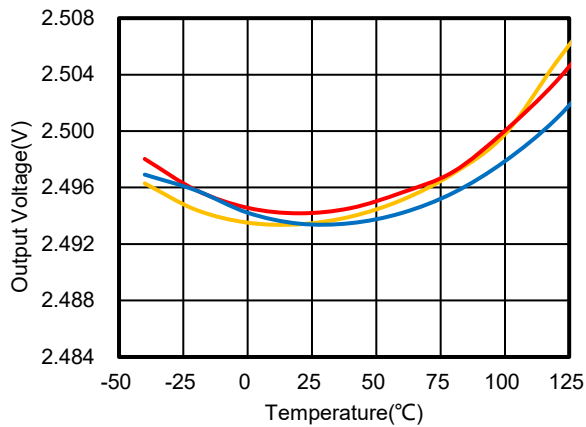
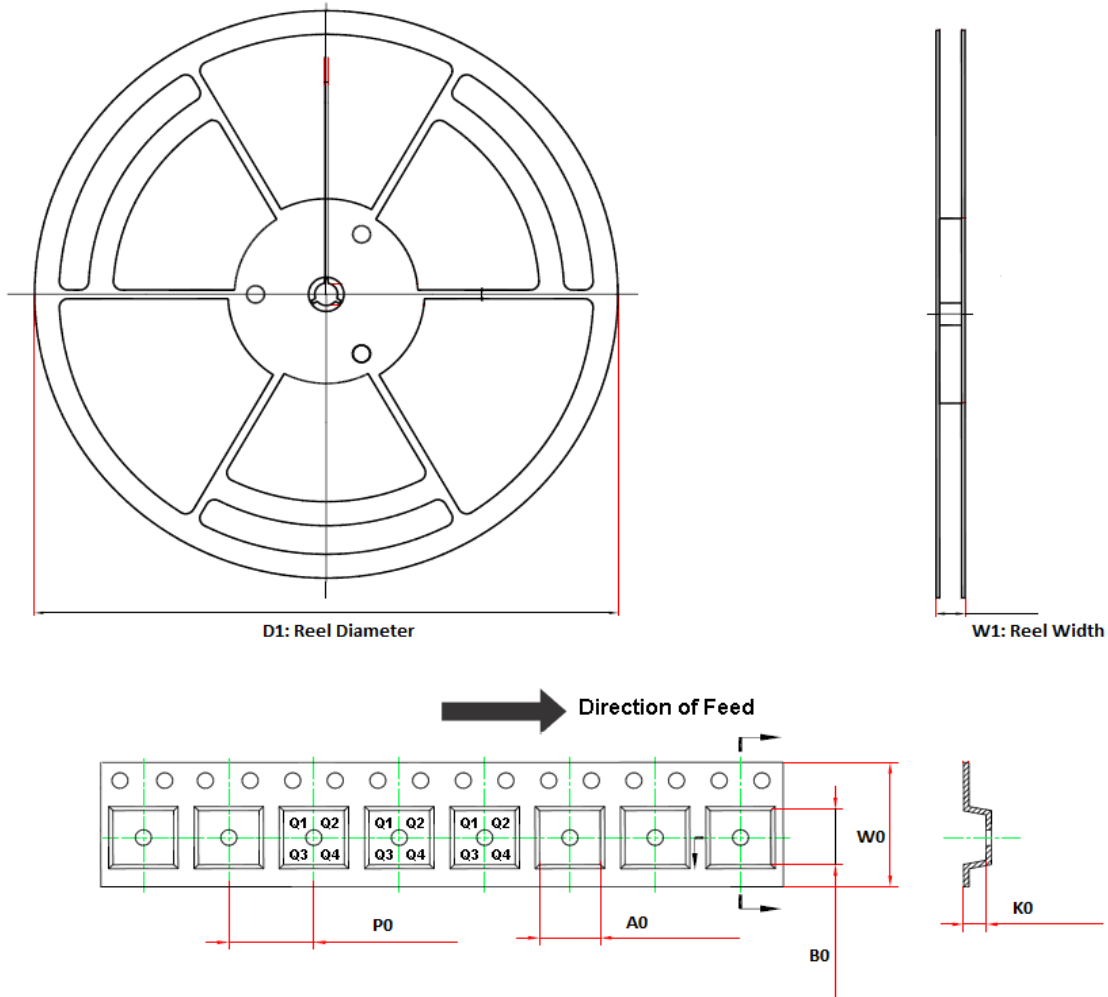

Figure 3. Reference Voltage vs. Temperature



Figure 4. Pulse Response

Tape and Reel Information



Order Number	Package	D1 (mm)	W1 (mm)	A0 (mm)	B0 (mm)	K0 (mm)	P0 (mm)	W0 (mm)	Pin1 Quadrant
TPR431B-S3TR	SOT23G-3	178	12.1	3.15	2.77	1.22	4.0	8.0	Q3
TPR431A-S3TR	SOT23G-3	178	12.1	3.15	2.77	1.22	4.0	8.0	Q3
TPR432B-S3TR	SOT23G-3	178	12.1	3.15	2.77	1.22	4.0	8.0	Q3
TPR432A-S3TR	SOT23G-3	178	12.1	3.15	2.77	1.22	4.0	8.0	Q3

Package Outline Dimensions

SOT23G-3

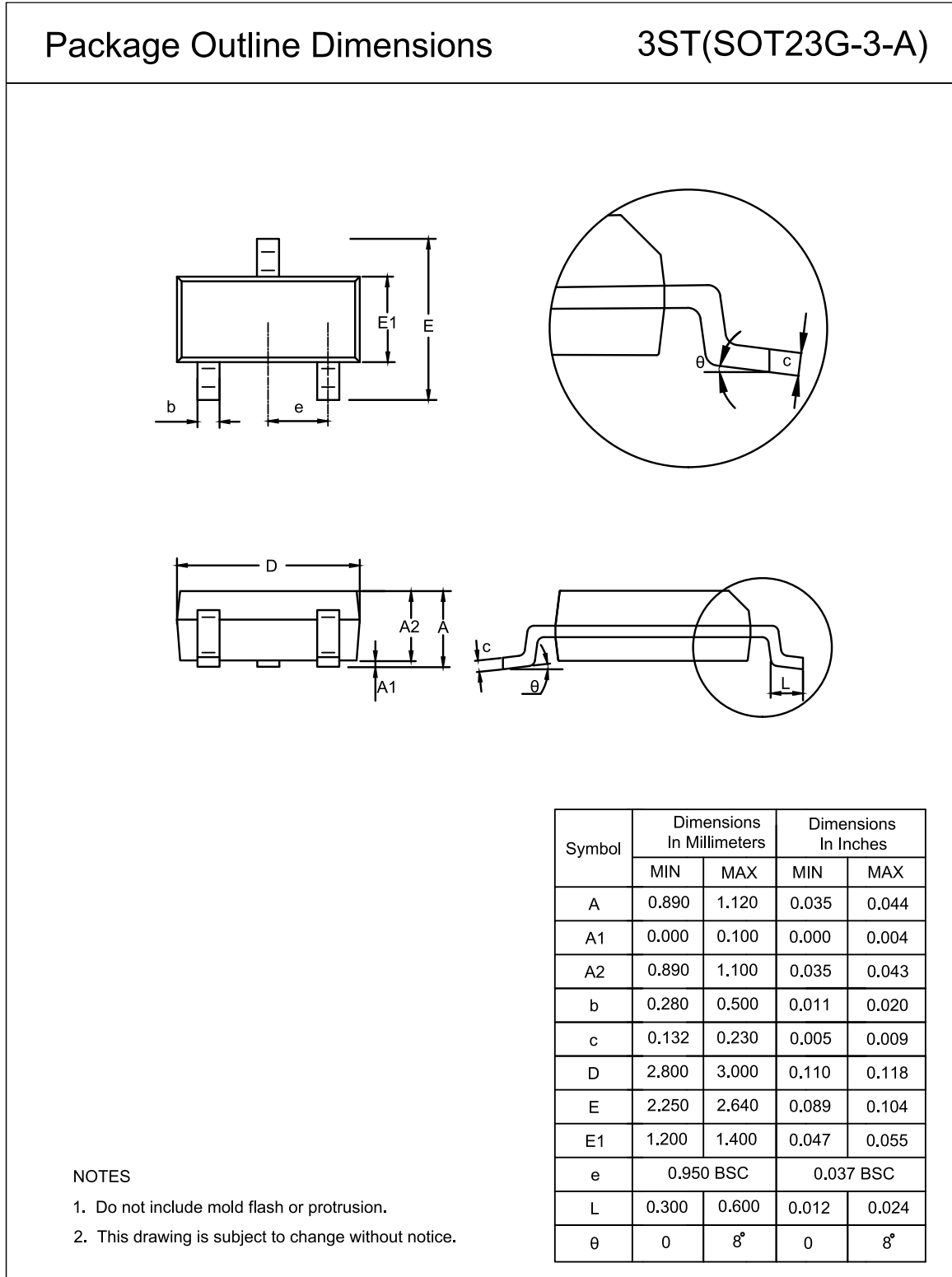

Order Information

Order Number	Operating Temperature Range	Package	Marking Information	MSL	Transport Media, Quantity	Eco Plan
TPR431B-S3TR	-40 to 125°C	SOT23G-3	R31	MSL3	Tape and Reel, 3000	Green
TPR431A-S3TR ⁽¹⁾	-40 to 125°C	SOT23G-3	R31	MSL3	Tape and Reel, 3000	Green
TPR432B-S3TR	-40 to 125°C	SOT23G-3	R32	MSL3	Tape and Reel, 3000	Green
TPR432A-S3TR ⁽¹⁾	-40 to 125°C	SOT23G-3	R32	MSL3	Tape and Reel, 3000	Green

(1) Future product, contact 3PEAK factory for more information and sample.

(2) Green: 3PEAK defines "Green" to mean RoHS compatible and free of halogen substances.

 **3PEAK and the 3PEAK logo are registered trademarks of 3PEAK INCORPORATED. All other trademarks are the property of their respective owners.**
