

## Data sheet

Commercial Art.No.: 25.313.3653.0

Panel header 8213 S / 6 DFLS M

Feed Through-Pin Header, 6 -pole, with solder pin connection, without marking, pitch:  
5,08 mm, series: 8214 S / 6 DFLS M

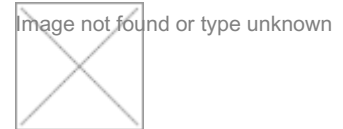

Commercial Art.No.	25.313.3653.0
EAN	4015573343542
Order Unit	50

Certificates / Approvals



## Technical data

### General

Modular spacing	5.08 mm
Connection type	Soldering connection
Soldering process	None
Packaging	Carton
Number of poles	6
Number of levels	1
Marking	No
Fastening	Flange
Mating direction towards (circuit) board	None

### Technical data

Rated current	6.5 A
Overvoltage Category I	1000 V
Overvoltage Category II	400 V
Overvoltage Category III	250 V
Rated impulse voltage	4 kV

### Technical Data UL/CSA

Voltage UL	300 V
Current field wiring	8 A
Current factory wiring	8 A
Voltage CSA	300 V
Current CSA	8 A

### Other

Type of insulation material	Thermoplastic
Color	Grey
Height	17.5 mm
Length	50.8 mm
Depth	17.1 mm
Material contact base	CuSn

Material contact surface	Sn
--------------------------	----

**Classification**

ECLASS 11	
ECLASS 8.1	27440402
ETIM 7.0	EC002637
ETIM 6.0	EC002637
ETIM 5.0	EC002637
ETIM 4.0	EC002637

**Product compliance**

ROHS conformity status	Compliant/Exempted
ROHS exceptions	III-6(c)
REACH-SVHC conformity status	Duty-To-Declare
REACH-SVHC substances	Lead
REACH-SVHC CAS numbers	7439-92-1

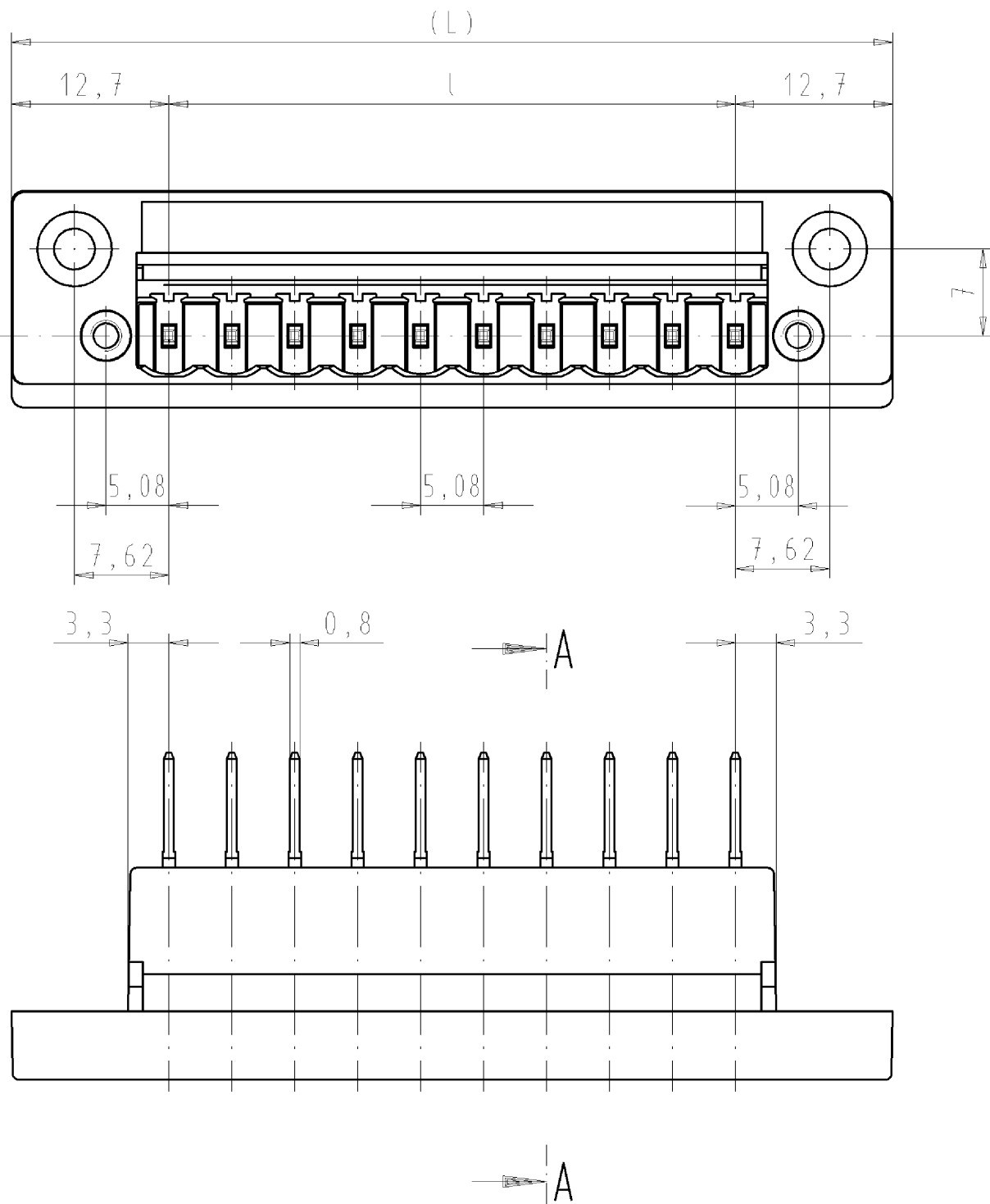

10-polige Ausführung gezeichnet  
drawn version 10-poles

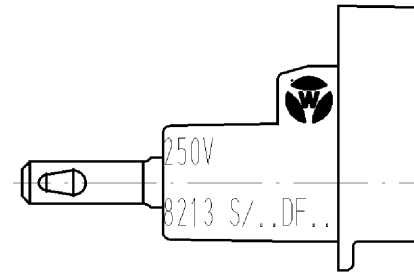

Schnitt A-A  
section A-A

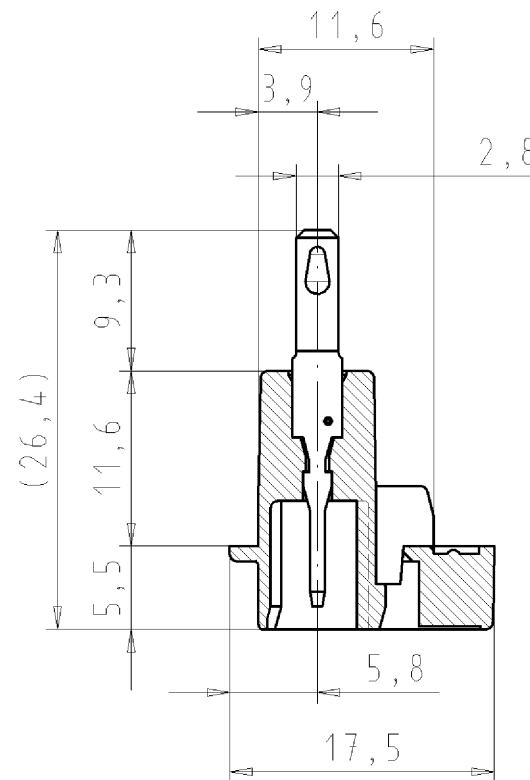

Weitere Daten siehe Katalog  
further data see catalog

Farbe colour	.F	Typ type
grau/grey	0	8213 S/2-24DFLS M
schwarz/black	1	8213 S/2-24DFLS SW M
grün/green	7	8213 S/2-24DFLS GN M

mit Löt-Steck-Anschluß mit Einpreßmutter  
with solder connection with press in nut

Artikel-Nr. part number	Pol pole	(L)	l	Artikel-Nr. part number	Pol pole	(L)	l
				25.313.4353.F	13	86,36	60,96
25.313.3253.F	2	30,48	5,08	25.313.4453.F	14	91,44	66,04
25.313.3353.F	3	35,56	10,16	25.313.4553.F	15	96,52	71,12
25.313.3453.F	4	40,64	15,24	25.313.4653.F	16	101,60	76,20
25.313.3553.F	5	45,72	20,32	25.313.4753.F	17	106,68	81,28
25.313.3653.F	6	50,80	25,40	25.313.4853.F	18	111,76	86,36
25.313.3753.F	7	55,88	30,48	25.313.4953.F	19	116,84	91,44
25.313.3853.F	8	60,96	35,56	25.313.5053.F	20	121,92	96,52
25.313.3953.F	9	66,04	40,64	25.313.5153.F	21	127,00	101,60
25.313.4053.F	10	71,12	45,72	25.313.5253.F	22	132,08	106,68
25.313.4153.F	11	76,20	50,80	25.313.5353.F	23	137,16	111,76
25.313.4253.F	12	81,28	55,88	25.313.5453.F	24	142,24	116,84

Tolerierung nach DIN 7167/Tolerance system acc. to DIN 7167.  
[This DIN-standard describes the envelope principle. According to the envelope principle the deviations of form and parallelism are limited by the size tolerances].

ja/yes  Stoffverbots- und Deklarationsliste nach UU-TQM-05/03 ist einzuhalten.  
Conformity with Wieland document UU-TQM-05/03 (list of prohibited / declarable hazardous substances) to be declared!

Freitoleranz nach CAD-Zeichnung, keine manuellen Änderungen  
General tolerance CAD - drawing, no manual modifications allowed

1. Verwendung: - Blatt: 1 von 1  
First Use: - Sheet: of

Werkstoff/Material	2010 Tag/Date	Name	Zeichnung Nr./Drawing No.	Index
gezeichnet/drawn	09.03.	Schmitt J.		
Maßstab/Scale	geprüft/checked		T	25.313.3253.0 01K
2:1	Normgepr. Stand. check			
Vol. mm <sup>3</sup> Ofl./Surf. mm <sup>2</sup>	Ersatz für/Replacement for: -			
wieland		Type	Benennung/Title	
Elektrische Verbindungen		8213 S/... DFLS M	GEHAUSESTIFTLISTE	
Änderung/Revision		Durchführung Rastmaß: 5,08 Header for panel mounting pitch 5,08		

Maße in mm/Dimensions are in mm

Weitergabe sowie Vervielfältigung dieses Dokuments, Verwertung und Mitteilung seines Inhalts sind verboten, soweit nicht ausdrücklich gestattet. Die Reproduktion, Distribution und Nutzung dieses Dokuments sowie die Kommunikation der Inhalte mit anderen ohne ausdrückliche Genehmigung ist untersagt.

253133253001K\_4\_CAD/20236\_Schnitt\_2010-03-09/1:45:31\_1.000