

# Sound processor IC

## BH3874AKS2

The BH3874AKS2 is a sound control IC for mini-component stereo. 4-ch input selector, vocal fade, volume, surround, 5-band graphic equalizer, dynamic bass, and 5-band spectrum analyzer are integrated into a single chip. Soft switch can reduce the switching noise occurred when volume, vocal fade, surround, and dynamic bass are switched.

### ●Applications

Mini component stereo, Micro component stereo, CD radio cassette players, and TV.

### ●Features

- 1) A single chip IC integrates all functions of volume, tone control, and spectrum analyzer.
- 2) Soft switching can reduce the noise occurred when volume, mode selector, surround, dynamic bass, and gain of graphic equalizer are switched.
- 3) 4-ch input selector, mode selector, volume, surround, graphic equalizer, dynamic bass, and spectrum analyzer.
- 4) Built-in matrix surround, pseudo stereo circuit, and band pass filter for spectrum analyzer.
- 5) Low distortion and low noise due to the BiCMOS process adopting resistance ladder volume.
- 6) Filters of dynamic bass and biamp can be set freely by the combination of LPF and HPF.

### ●Absolute maximum ratings (Ta=25°C)

Parameter	Symbol	Limits	Unit
Power supply voltage	V <sub>CC</sub>	10.0	V
Power dissipation	P <sub>d</sub>	1200*	mW
Operating temperature range	T <sub>opr</sub>	-12 to +85	°C
Storage temperature range	T <sub>stg</sub>	-55 to +125	°C

\* Reduced by 12mW for each increase in Ta of 1°C over 25°C.  
A standard board, 70×70×1.6mm, shall be mounted.

### ●Recommended operating conditions (Ta=25°C)

Parameter	Symbol	Min.	Typ.	Max.	Unit
Power supply voltage	V <sub>CC</sub>	8.0	–	9.5	V

Audio ICs

●Block diagram

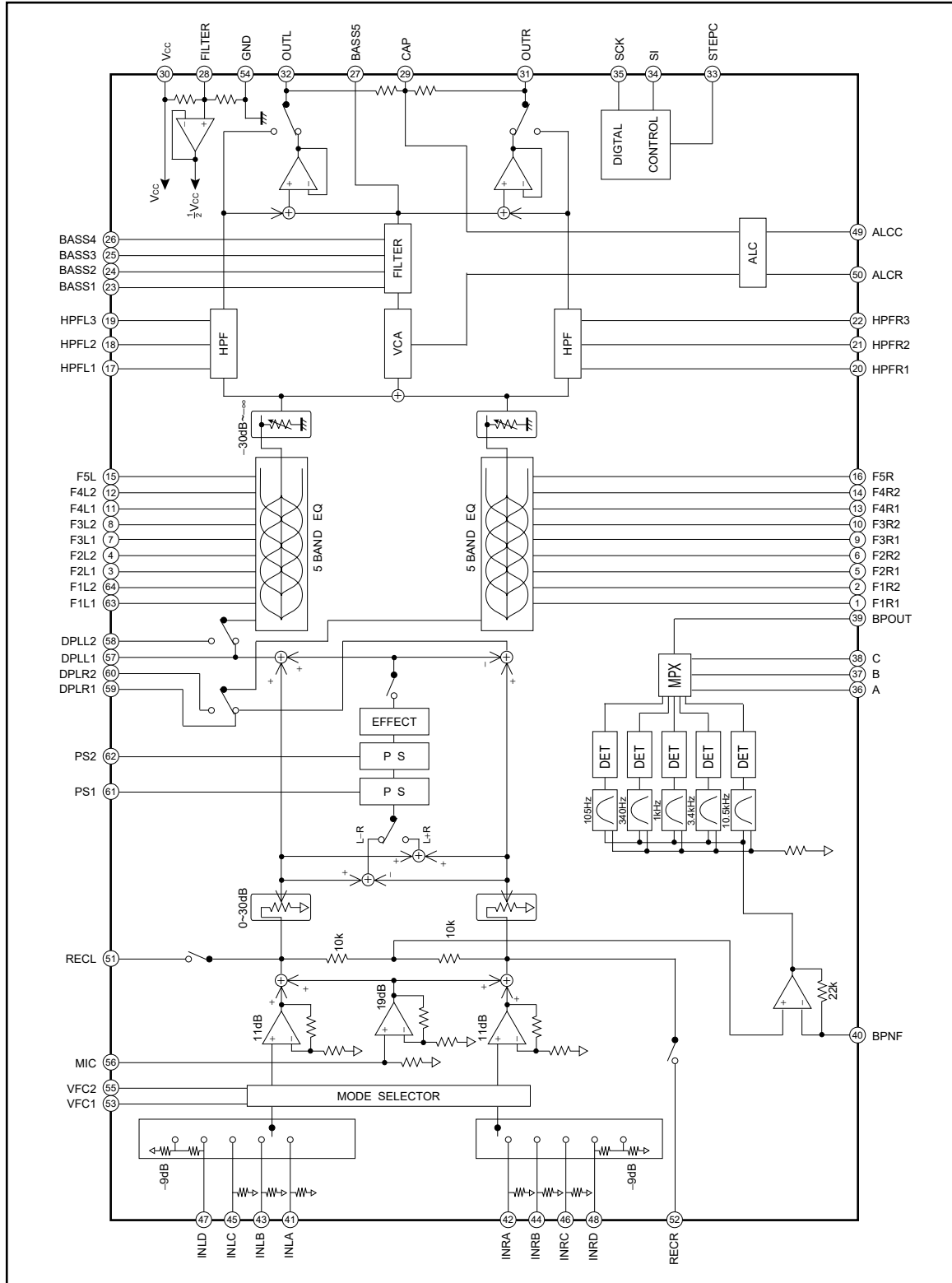

## Audio ICs

## ●Pin descriptions

Pin No.	Pin name	Function	Pin No.	Pin name	Function
1	F1R1	Rch GREQ f1 filter setting pin	33	STEPC	Time constant attachment for switching shock protection
2	F1R2	Rch GREQ f1 filter setting pin	34	SI	Serial data latch receiving pin
3	F2L1	Lch GREQ f2 filter setting pin	35	SCK	Serial clock receiving pin
4	F2L2	Lch GREQ f2 filter setting pin	36	A	Parallel data receiving pin
5	F2R1	Rch GREQ f2 filter setting pin	37	B	Parallel data receiving pin
6	F2R2	Rch GREQ f2 filter setting pin	38	C	Parallel data receiving pin
7	F3L1	Lch GREQ f3 filter setting pin	39	BPOUT	Output pin for spectrum analyzer
8	F3L2	Lch GREQ f3 filter setting pin	40	BPNF	Spectrum analyzer level setting pin
9	F3R1	Rch GREQ f3 filter setting pin	41	INLA	Lch Sound signal input pin A
10	F3R2	Rch GREQ f3 filter setting pin	42	INRA	Rch Sound signal input pin A
11	F4L1	Lch GREQ f4 filter setting pin	43	INLB	Lch Sound signal input pin B
12	F4L2	Lch GREQ f4 filter setting pin	44	INRB	Rch Sound signal input pin B
13	F4R1	Rch GREQ f4 filter setting pin	45	INLC	Lch Sound signal input pin C
14	F4R2	Rch GREQ f4 filter setting pin	46	INRC	Rch Sound signal input pin C
15	F5L	Lch GREQ f5 filter setting pin	47	INLD	Lch Sound signal input pin D
16	F5R	Rch GREQ f5 filter setting pin	48	INRD	Rch Sound signal input pin D
17	HPFL1	Lch High-pass filter setting pin	49	ALCC	Time constant of ALC setting pin
18	HPFL2	Lch High-pass filter setting pin	50	ALCR	ALC level setting pin
19	HPFL3	Lch High-pass filter setting pin	51	RECL	Lch RECOU output pin
20	HPFR1	Rch High-pass filter setting pin	52	RECR	Rch RECOU output pin
21	HPFR2	Rch High-pass filter setting pin	53	VFC1	Vocal fade filter setting pin
22	HPFR3	Rch High-pass filter setting pin	54	GND	Ground pin
23	BASS1	Dynamic bass filter setting pin	55	VFC2	Vocal fade filter setting pin
24	BASS2	Dynamic bass filter setting pin	56	MIC	Input pin for microphone
25	BASS3	Dynamic bass filter setting pin	57	DPLL1	Lch Output pin for DPL
26	BASS4	Dynamic bass filter setting pin	58	DPLL2	Lch Input pin for DPL
27	BASS5	Biamp output pin	59	DPLR1	Rch Output pin for DPL
28	FILTER	V <sub>cc</sub> /2 Pin	60	DPLR2	Rch Input pin for DPL
29	CAP	ALC trap frequency setting pin	61	PS1	Surround setting pin
30	V <sub>cc</sub>	Power supply pin	62	PS2	Surround setting pin
31	OUTR	Rch Sound signal output pin	63	F1L1	Lch GREQ f1 Filter Setting Pin
32	OUTL	Lch Sound signal output pin	64	F1L2	Lch GREQ f1 Filter Setting Pin

Audio ICs

●Input / output circuits

Pin No.	Pin name	Pin voltage	Equivalent circuit	Pin description
41 42 43 44 45 46	INLA INRA INLB INRB INLC INRC	$V_{CC}/2$		A pin for inputting a sound signal. It is suitable for input of CD, MD, tuner and tape. The input impedance is 50kΩ (upon typical setting).
54	GND	—	—	A ground pin
53	VFC1	$V_{CC}/2$		A pin for setting vocal fade frequency characteristic.
55	VFC2	$V_{CC}/2$		A pin for setting vocal fade frequency characteristic.
47 48	INLD INRD	$V_{CC}/2$		A pin for inputting a sound signal. The input impedance is 20kΩ (upon typical setting). It is possible to set 0dB or -9dB.
51 52	RECL RECR	$V_{CC}/2$		A pin for outputting a sound signal for recording.

Audio ICs

Pin No.	Pin name	Pin voltage	Equivalent circuit	Pin description
63 1 7 9	F1L1 F1R1 F3L1 F3R1	$V_{cc}/2$		A pin for setting graphic equalizer frequency characteristic.
64 2 8 10	F1L2 F1R2 F3L2 F3R2	$V_{cc}/2$		A pin for setting graphic equalizer frequency characteristic.
15 16	F5L F5R	$V_{cc}/2$		A pin for setting graphic equalizer frequency characteristic.
56	MIC	$V_{cc}/2$		A pin for inputting a microphone signal. The input impedance is 10kΩ (upon typical setting).
3 5 11 13	F2L1 F2R1 F4L1 F4R1	$V_{cc}/2$		A pin for setting graphic equalizer frequency characteristic.
4 6 12 14	F2L2 F2R2 F4L2 F4R2	$V_{cc}/2$		A pin for setting graphic equalizer frequency characteristic.

Audio ICs

Pin No.	Pin name	Pin voltage	Equivalent circuit	Pin description
30	Vcc	–	–	Power supply pin.
57 59	DPLL1 DPLR1	Vcc/2		A pin for outputting DPL.
58 60	DPLL2 DPLR2	Vcc/2		A pin for inputting DPL.
61 62	PS1 PS2	Vcc/2		A pin for setting surround phase shifter.
17 20	HPFL1 HPFR1	Vcc/2		A pin for setting cut-off frequency of HPF.
18 21	HPFL2 HPFR2	Vcc/2		A pin for setting cut-off frequency of HPF.

Audio ICs

Pin No.	Pin name	Pin voltage	Equivalent circuit	Pin description
19 22	HPFL3 HPFR3	$V_{cc}/2$		A pin for setting cut-off frequency of HPF.
50	ALCR	-		A pin for setting threshold to set the ALC.
23 25	BASS1 BASS3	$V_{cc}/2$		A pin for setting Dynamic bass (Biamp) frequency characteristic.
24 26	BASS2 BASS4	$V_{cc}/2$		A pin for setting Dynamic bass (Biamp) frequency characteristic.
27	BASS5	$V_{cc}/2$		A pin for outputting Biamp.

Audio ICs

Pin No.	Pin name	Pin voltage	Equivalent circuit	Pin description
28	FILTER	$V_{cc}/2$		A pin for inputting $V_{cc}/2$ from outside of IC.
54	GND	—	—	A ground pin.
32 31	OUTL OUTR	$V_{cc}/2$		A pin for outputting a sound signal.
29	CAP	$V_{cc}/2$		A pin for specifying trap frequency of ALC.
49	ALCC	0		A pin for setting attack time and release time of ALC.
35	SCK	—		A pin for inputting a signal clock.



Audio ICs

Pin No.	Pin name	Pin voltage	Equivalent circuit	Pin description
34	SI	-		A pin for inputting a serial data.
33	STPC	-		Time constant attachment for switching shock protection.
36	A	-		A pin for inputting a parallel data.
37	B			
38	C			
39	BPOUT	-		A pin for outputting a spectrum analyzer B.P.F..
40	BPNF	$V_{cc}/2$		A pin for adjusting gain of non-inverting amplifier in spectrum analyzer.

## Audio ICs

## ●Electrical characteristics

(Unless otherwise noted, Ta=25°C, Vcc=9V, f=1kHz, Rg=600Ω, RL=10kΩ, VIN=300mVrms, INPUT SELECTOR=Ach, MODE SELECTOR=Through, VOLUME=0dB, SURROUND=0dB, GRAPHIC EQUALIZER=0dB, DYNAMIC BASS=0dB, SPECTRUM ANALYZER=RESET)

Parameter	Symbol	Min.	Typ.	Max.	Unit	Conditions	Input pin	Measurement pin	Data setting								Switch control table						
									[1]	[2]	[3]	[4]	[5]	[6]	[7]	[8]	SW 1/4	SW 2/5	SW 3/6	SW 7	SW 8		
Circuit current	IQ	-	40	60	mA	No signal, after power on.	-	30	-	-	-	-	-	-	-	-	-	-	1	1	1	2	1
Maximum input voltage	VIM	0.4	0.7	-	Vrms	THD=1%	41 42	32 31	00	05	03	04	0C	02	0A	06	81	07	1	1	1	2	1
Maximum output voltage	VOM	2.0	2.5	-	Vrms	THD=1%	41 42	32 31	00	05	03	04	0C	02	0A	06	81	07	1	1	1	2	1
Voltage gain	GV	9	11	13	dB		41 42	32 31	00	05	03	04	0C	02	0A	06	81	07	1	1	1	2	1
Total harmonic distortion rate	THD	-	0.01	0.05	%	VIN=150mVrms, 400Hz-30kHz BPF	41 42	32 31	00	05	03	04	0C	02	0A	06	81	07	1	1	1	2	1
Output noise voltage *	VNO	-	35	50	μVrms	Biamp=0dB, DIN AUDIO	41 42	32 31	00	15	03	04	0C	02	0A	06	89	07	1	2	-	2	1
Residual output noise voltage *	VMNO	-	5	20	μVrms	Rg=0Ω, Volume=-∞, Biamp=0dB, DIN AUDIO	41 42	32 31	00	15	03	04	0C	02	0A	06	89	07	1	2	-	2	1
Cross talk *	CT	70	80	-	dB	Biamp=0dB, Rg=0Ω, DIN AUDIO	41 42	31 32	00	15	03	04	0C	02	0A	06	81	07	1/1	1/2	1/-	2	1
Channel balance	CB	-1.5	0	1.5	dB	Lch reference	-	-	-	-	-	-	-	-	-	-	-	-	-	-	-	-	-
Selector A-C Input impedance	RIN	35	50	65	kΩ		41 42 43 44 45 46	41 42 43 44 45 46	-	-	-	-	-	-	-	-	-	-	1 1 2 2 3 3	1	2	2	1
Selector D Input impedance	RIND	10	20	30	kΩ		47 48	47 48	-	-	-	-	-	-	-	-	-	-	4 4	1	2	2	1
Maximum attenuation *	ATTMAX	86	95	-	dB	DIN AUDIO	41 42	32 31	F8	05	03	04	0C	02	0A	06	81	07	1	1	1	2	1
Vocal fade suppression quantity	GVF	25	30	-	dB		41,42 41,42	32 31	00	25	03	04	0C	02	0A	06	81	07	1	1	1	2	1
Graphic equalizer boost gain set error (Set 2dB, 4dB, 6dB)	VGQBL	-2	0	2	dB	VIN=100mVrms, fn=100Hz, 300Hz, 1kHz, 3kHz, or 10kHz	41 42	32 31	00	05	03	74 04 04 04 04	0C 7C 0C 0C 0C	02 02 72 02 02	0A 0A 0A 7A 0A	06 06 06 06 76	81	07	1	1	1	2	1
Graphic equalizer boost gain set error (Set 8dB, 10dB, 12dB)	VGQBH	-3	0	3	dB	VIN=100mVrms, fn=100Hz, 300Hz, 1kHz, 3kHz, or 10kHz	41 42	32 31	00	05	03	74 04 04 04 04	0C 7C 0C 0C 0C	02 02 72 02 02	0A 0A 0A 7A 0A	06 06 06 06 76	81	07	1	1	1	2	1
Graphic equalizer cut gain set error (Set -2dB, -4dB, -6dB)	VGQCL	-2	0	2	dB	VIN=100mVrms, fn=100Hz, 300Hz, 1kHz, 3kHz, or 10kHz	41 42	32 31	00	05	03	E4 04 04 04 04	0C EC 0C 0C 0C	02 02 E2 02 02	0A 0A 0A EA 0A	06 06 06 06 E6	81	07	1	1	1	2	1
Graphic equalizer cut gain set error (Set -8dB, -10dB, -12dB)	VGQCL	-3	0	3	dB	VIN=100mVrms, fn=100Hz, 300Hz, 1kHz, 3kHz, or 10kHz	41 42	32 31	00	05	03	E4 04 04 04 04	0C EC 0C 0C 0C	02 02 E2 02 02	0A 0A 0A EA 0A	06 06 06 06 E6	81	07	1	1	1	2	1
Graphic equalizer channel balance	GQCB	-1.5	0	1.5	dB	Lch reference	-	-	-	-	-	-	-	-	-	-	-	-	-	-	-	-	-
Dynamic bass boost gain	VBB	15	18	21	dB	VIN=40mVrms, fn=75Hz, 49pin=GND	41,42 41,42	32 31	00	E5	03	04	0C	02	0A	06	81	07	1	1	1	2	2
Dynamic bass boost channel balance	VBCB	-1.5	0	1.5	dB	Lch reference	-	-	-	-	-	-	-	-	-	-	-	-	-	-	-	-	-
Input separation *	CTIN	80	90	-	dB	DIN AUDIO	41 42	51 52	00	05	03	04	0C	02	0A	06	41 C1 61	07	1	1	1	2	1
Input mute attenuation *	VINMU	80	90	-	dB	DIN AUDIO	41 42	32 31	00	05	03	04	0C	02	0A	06	01	07	1	1	1	2	1
Microphone voltage gain	GMIC	17	19	21	dB	VIN=100mVrms	56	32 31	00	05	03	04	0C	02	0A	06	81	07	1	2	-	1	1
Microphone mute attenuation *	VMICMU	80	90	-	dB	VIN=100mVrms, DIN AUDIO	56	32 31	00	15	03	04	0C	02	0A	06	81	07	1	2	-	1	1
RECOUT voltage gain	GREC	9	11	13	dB		41 42	51 52	00	05	03	04	0C	02	0A	06	81	07	1	1	1	2	1
RECOUT mute attenuation*	VRECMU	80	90	-	dB	DIN AUDIO	41 42	51 52	00	0D	03	04	0C	02	0A	06	81	07	1	1	1	2	1
Selector D attenuation	D2ATT	-7	-9	-11	dB		49 50	32 31	00	05	03	04	0C	02	0A	06	E1	07	4	1	1	2	1
Surround maximum voltage gain	VSUMAX	7	9	11	dB	VIN=100mVrms, fn=10kHz	41 42	32 31	00	05	1B	04	0C	02	0A	06	81	07	1	1	1	2	1

© Design against radiation-proof is not made.

\* VP-9690A (Average value detection, effective value display) DIN AUDIO filter by Matsushita Communication is used for \* measurement.

Audio ICs

Parameter	Symbol	Min.	Typ.	Max.	Unit	Conditions	Input pin	Measurement pin	Data setting								Switch control table						
									[1]	[2]	[3]	[4]	[4]	[5]	[5]	[6]	[7]	[8]	SW 1/4	SW 2/5	SW 3/6	SW 7	SW 8
Simulated stereo maximum voltage gain Lch	VMONL	6.5	8.5	10.5	dB	$V_{IN}=100mV_{rms}$ $f_{IN}=680Hz$	41,42 41,42	32 31	00	05	1B	04	0C	02	0A	06	91	07	1	1	1	2	1
Simulated stereo maximum voltage gain Rch	VMONR	11.3	13.3	15.3	dB	$V_{IN}=100mV_{rms}$ $f_{IN}=680Hz$	41,42 41,42	32 31	00	05	1B	04	0C	02	0A	06	91	07	1	1	1	2	1
Spectrum analyzer maximum output level	VMAX	4.0	4.8	-	V	$V_{IN}=-19dBV$	41,42 41,42	39	00	05	03	04	0C	02	0A	06	81	47 C7 27 A7 67	1	1	1	2	1
Spectrum analyzer output offset voltage	VOS	0	30	200	mV	$V_{IN}=0V_{rms}$	-	39	00	05	03	04	0C	02	0A	06	81	47 C7 27 A7 67	-	-	-	-	-
Spectrum analyzer standard output level	VST	0.65	1.35	1.7	V	$V_{IN}=-37dBV$ $f_{IN}=105Hz, 340Hz, 1kHz,$ $3.4kHz, \text{ or } 10.5kHz$	41,42 41,42	39	00	05	03	04	0C	02	0A	06	81	47 C7 27 A7 67	1	1	1	2	1
Ripple rejection *	RR	31	-	-	dB	$V_{RR}=100mV_{rms}$ $f_{RR}=100Hz, \text{ DIN AUDIO}$	30	32 31	00	15	03	04	0C	02	0A	06	81	07	1	2	-	2	1

© Design against radiation-proof is not made.

\* VP-9690A (Average value detection, effective value display) DIN AUDIO filter by Matsushita Communication is used for \* measurement.

Audio ICs

● Measurement circuit

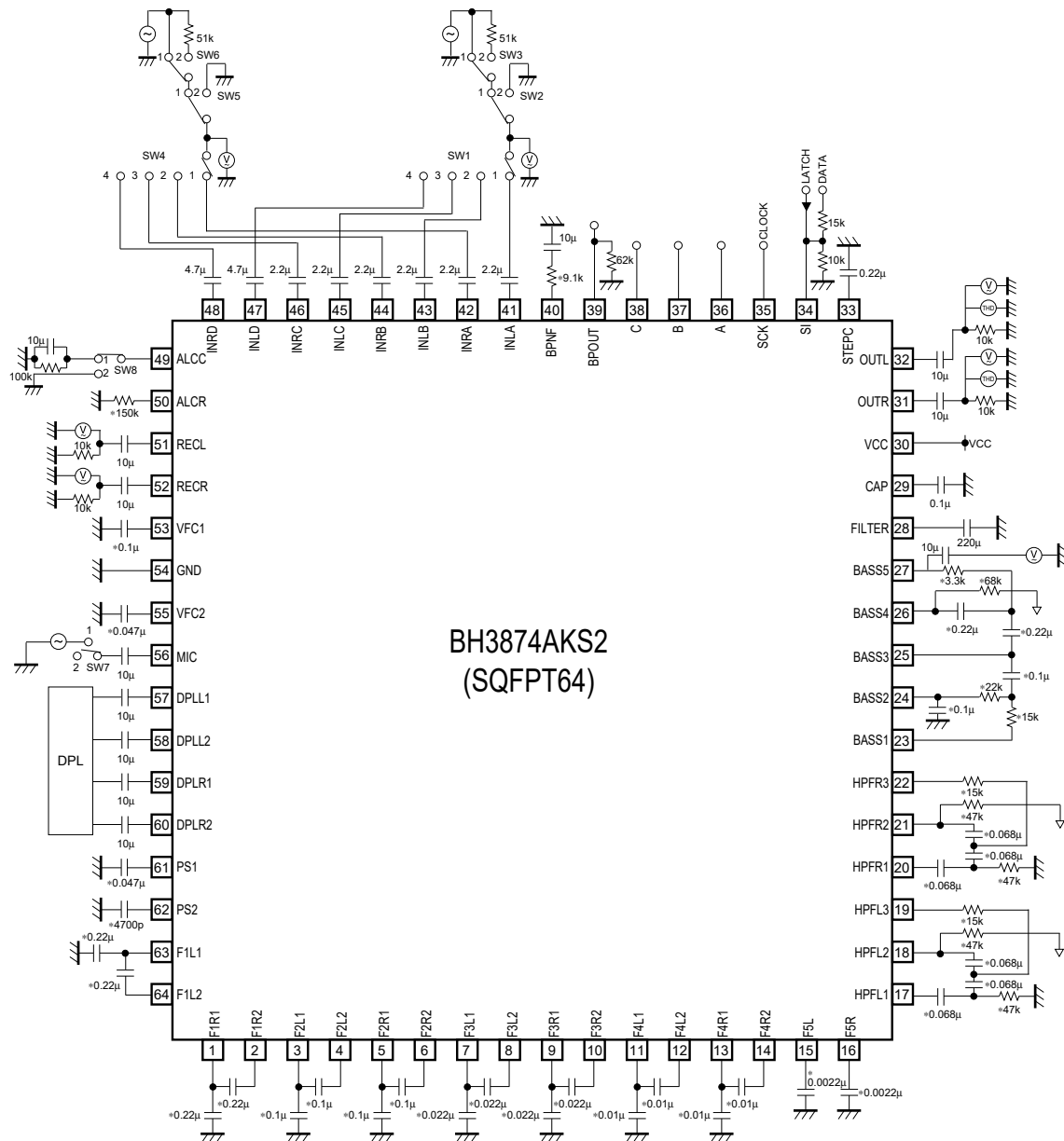

Fig.1

○ Recommendable External Parts

1. Element marked with \*
  - Carbon-film resistor : ±1%
  - Film capacitor : ±1%
  - Ceramic capacitor : ±1%
2. Unless specified particularly, use the following external parts:
  - Carbon-film resistor : ±5%
  - Film capacitor : ±20%
  - Electrolytic capacitor : ±20%

○ Notes on wiring

1. GND shall be wired solidly.
2. Wiring pattern of SI and SCK shall be away from that of analog unit and cross talk shall not be acceptable.
3. Lines of SI and SCK shall not be parallel if possible. The lines shall be shielded, if they are adjacent to each other.

## Audio ICs

## ●Circuit operations

## Timing of Control Signal

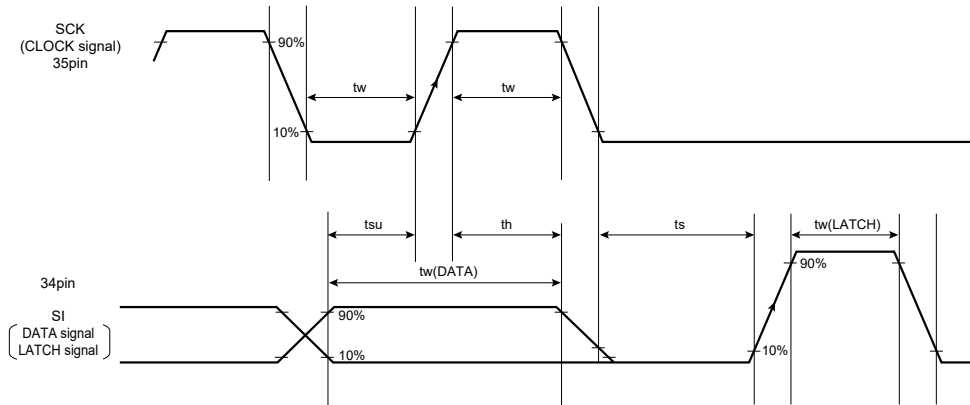

Fig.2

DATA (SI) is read at a rising edge of CLOCK.

DATA is fixed by the rising edge of LATCH.

Be sure to set SCK and SI to Low after latching.

When the CLOCK signal is High, it doesn't accept LATCH signal.

Constant of Timing Chart ( $T_a=25^\circ\text{C}$ )

Parameter	Symbol	Min.	Typ.	Max.	Unit
"High" Input voltage	$V_{IH}$	3.3	5.0	6.0	V
"Middle" Input voltage	$V_{IM}$	1.8	2.0	2.4	V
"Low" Input voltage	$V_{IL}$	-0.3	0	1.2	V
Clock width	$t_w$	2.0	-	-	$\mu\text{s}$
Data width	$t_w(\text{DATA})$	4.0	-	-	$\mu\text{s}$
Latch width	$t_w(\text{LATCH})$	2.0	-	-	$\mu\text{s}$
Setup time (DATA→CLOCK)	$t_{su}$	1.0	-	-	$\mu\text{s}$
Hold time (CLOCK→CLOCK)	$t_h$	1.0	-	-	$\mu\text{s}$
Setup time (DATA, CLOCK→LATCH)	$t_s$	1.0	-	-	$\mu\text{s}$

\* Serial signal SI is judging DATA and LATCH in the difference of the voltage level.

\* In the application schematic, it is changing 0-5V 3 line serial data into the 2 line serial data at the voltage with the resistance and the diode of the external.

We request enough examination, because there is a case where the voltage which is changed by the ability for the microcomputer to drive and the external parts.

Audio ICs

When transmitting more than one piece of data at once, we request the following serial control transmission.

(1) Timing of serial data and latch

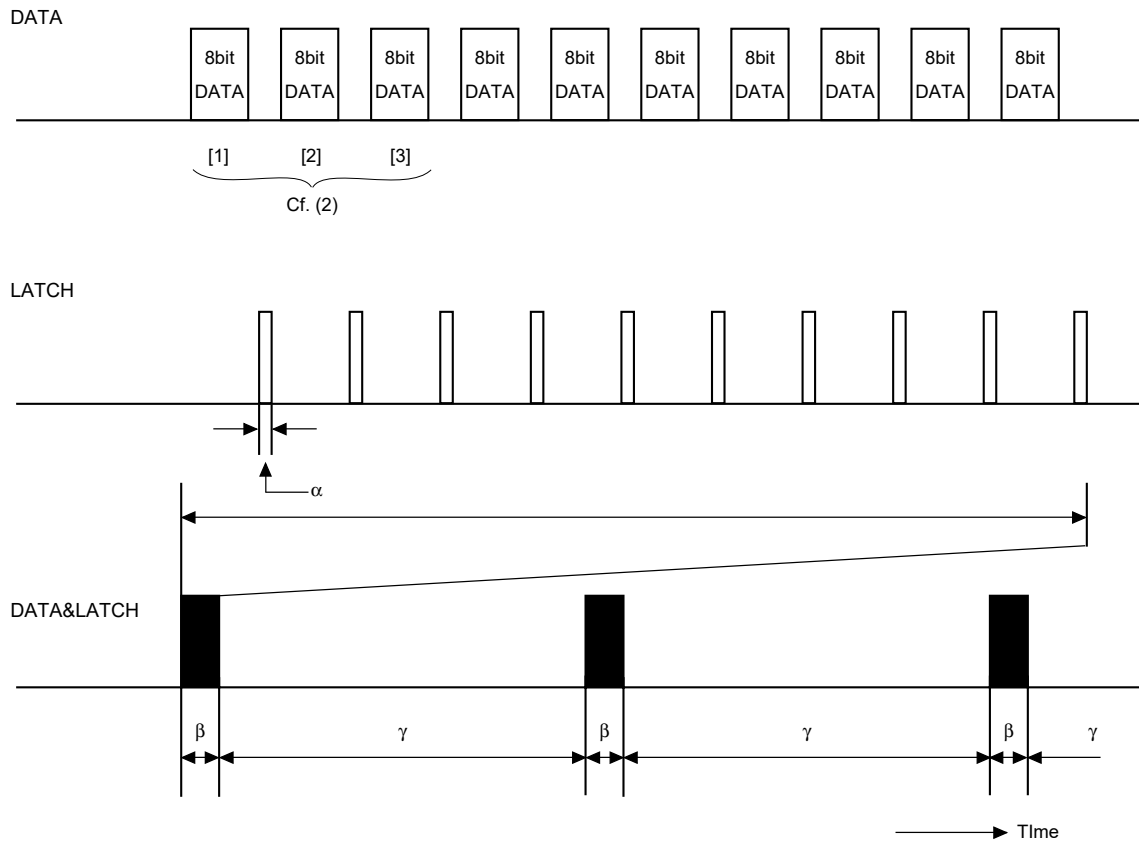

Fig.3

	Parameter	Time
$\alpha$	Latch width	More than 2.0 $\mu$ s
$\beta$	The time which transmits more than one piece of data at once	Less than 2.5ms
$\gamma$	The time which sends more than one piece of the following data after sending more than one piece of data (When the capacitor of 33 pin is 0.22 $\mu$ F.)	More than 100ms

(2) About the order which transmits more than one piece of DATA at once

When transmitting more than one piece of DATA including [1], [2] or [3] at once, transmit DATA of [1], [2] or [3] of the data format first.

In case of transmitting some data from [1] until [8], transmit only necessary DATA in order from [1].

(3) About DATA needing the timing of (1)

DATA needing the timing of (1) are DATA [1], [2] and [3]. Even if one data of DATA [1], [2] and [3] is transmitted, follow the timing of (1).

In case of transmitting some data from [4] until [8], the timing of (1) need not be followed. In the case, there are no problems if the constant of timing chart in the preceding page is satisfied.

## Audio ICs

---

### (4) Relation of the serial data and 33pin capacitor

The interval  $\gamma$  of the data and the data can be more shortly set by changing the capacitor of 33pins.  
(Ex. When making the changing speed of VOLUME faster)

The relation between the interval  $\gamma$  of the data and the data and the capacitor of 33pin is as follows.

33pin Capacitor	The interval of the data and the next data
0.047 $\mu$ F	More than 25ms
0.1 $\mu$ F	More than 50ms
0.22 $\mu$ F	More than 100ms

Note: It is possible to do the interval of the data and the next data more shortly by changing 33pin capacitor into 0.047 $\mu$ F. However, the switching sound becomes rather bigger than the switching sound of setting 0.1 $\mu$ F about the switching sound of VOLUME, DBASS, SURROUND, MODE SELECTOR.

### (5) Others

If there is common impedance in GND of the IC, the switching sound something occurs by changing the mode.  
Wiring pattern of SI and SCK shall be away from that of analog unit and cross talk shall not be acceptable.

## Audio ICs

## SERIAL CONTROL DATA FORMAT

	D00	D01	D02	D03	D04	D05	D06	D07
[1]	● VOLUME					0	0	0
	D10	D11	D12	D13	D14	D15	D16	D17
[2]	● MODE SELECTOR			MIC	REC OUT	1	0	1
	D20	D21	D22	D23	D24	D25	D26	D27
[3]	● DYNAMIC BASS / Biamp			● SURROUND EFFECT		0	1	1
	D30	D31	D32	D33	D34	D35	D36	D37
[4]	▲ GRAPHIC EQUALIZER f1 / f2				GREQ 0 : f1 1 : f2	1	0	0
	D40	D41	D42	D43	D44	D45	D46	D47
[5]	▲ GRAPHIC EQUALIZER f3 / f4				GREQ 0 : f3 1 : f4	0	1	0
	D50	D51	D52	D53	D54	D55	D56	D57
[6]	▲ GRAPHIC EQUALIZER f5				DPL 0 : OFF 1 : ON	1	1	0
	D60	D61	D62	D63	D64	D65	D66	D67
[7]	INPUT SELECTOR			SURROUND / STEREO	DYNAMIC BASS / Biamp	0	0	1
	D70	D71	D72	D73	D74	D75	D76	D77
[8]	SPECTRUM ANALYZER			*	*	1	1	1

\* Don't Care

As for functions of the ● and ▲ mark, measures to reduce step noise are done.  
 Because the functions of no marks have no measures of step noise, please supply mute.  
 As for the ● mark, it becomes a soft switch method.  
 As for the ▲ mark, it takes measures to decrease DC offset voltage.



## Audio ICs

## [1] VOLUME ATTENUATION

ATT quantity	D00	D01	D02	D03	D04	D05	D06	D07
0.0dB	0	0	0	0	0	0	0	0
-2.0dB	1	0	0	0	0			
-4.0dB	0	1	0	0	0			
-6.0dB	1	1	0	0	0			
-8.0dB	0	0	1	0	0			
-10.0dB	1	0	1	0	0			
-12.0dB	0	1	1	0	0			
-14.0dB	1	1	1	0	0			
-16.0dB	0	0	0	1	0			
-18.0dB	1	0	0	1	0			
-20.0dB	0	1	0	1	0			
-22.0dB	1	1	0	1	0			
-24.0dB	0	0	1	1	0			
-26.0dB	1	0	1	1	0			
-28.0dB	0	1	1	1	0			
-30.0dB	1	1	1	1	0			
-32.0dB	0	0	0	0	1			
-34.0dB	1	0	0	0	1			
-36.0dB	0	1	0	0	1			
-38.0dB	1	1	0	0	1			
-40.0dB	0	0	1	0	1			
-44.0dB	1	0	1	0	1			
-48.0dB	0	1	1	0	1			
-52.0dB	1	1	1	0	1			
-56.0dB	0	0	0	1	1			
-60.0dB	1	0	0	1	1			
-64.0dB	0	1	0	1	1			
-68.0dB	1	1	0	1	1			
-72.0dB	0	0	1	1	1			
-76.0dB	1	0	1	1	1			
-82.0dB	0	1	1	1	1			
-∞	1	1	1	1	1			

## Audio ICs

## [2] MODE SELECTOR, MIC, REC OUT

MODE	D10	D11	D12	D13	D14	D15	D16	D17
THROUGH	0	0	0	MIC 0 : ON 1 : MUTE	REC OUT 0 : ON 1 : MUTE	1	0	1
THROUGH	1	0	0					
THROUGH	0	1	0					
THROUGH	1	1	0					
VOCAL FADE	0	0	1					
Lch MONAULAL	1	0	1					
Rch MONAULAL	0	1	1					
L+R	1	1	1					

Note : About input selector, mode selector is cleared when MUTE of the input selector is chosen.  
When MUTE of the input selector is canceled, choose the mode selector, too.  
The MUTE command of the input selector has priority over the command of the mode selector.

## [3] Dynamic Bass / Biamp Effect, Surround Effect

## (a) Dynamic Bass / Biamp Effect

The effect quantity in biamp is different from the value of the below table.

GAIN	D20	D21	D22	D23	D24	D25	D26	D27
0dB	0	0	0	Refer to the Surround Effect		0	1	1
0dB	1	0	0					
3dB	0	1	0					
6dB	1	1	0					
9dB	0	0	1					
12dB	1	0	1					
15dB	0	1	1					
18dB	1	1	1					

## (b) Surround Effect

The effect quantity in simulated stereo mode is different from the value of the below table.

GAIN	D20	D21	D22	D23	D24	D25	D26	D27
0dB	Refer to the Dynamic Bass Effect			0	0	0	1	1
3dB				1	0			
6dB				0	1			
9dB				1	1			

Note : GAIN is the name given to the transfer data.  
Depending on the values of the external constant, the specified gain may not be output.

## Audio ICs

[4] Graphic Equalizer f1 / f2

GAIN	D30	D31	D32	D33	D34	D35	D36	D37
+12dB	1	1	1	1	GREQ SELECT 0 : f1 1 : f2	1	0	0
+12dB	0	1	1	1				
+10dB	1	0	1	1				
+8dB	0	0	1	1				
+6dB	1	1	0	1				
+4dB	0	1	0	1				
+2dB	1	0	0	1				
0dB	0	0	0	1				
0dB	0	0	0	0				
-2dB	1	0	0	0				
-4dB	0	1	0	0				
-6dB	1	1	0	0				
-8dB	0	0	1	0				
-10dB	1	0	1	0				
-12dB	0	1	1	0				
-12dB	1	1	1	0				

Note : GAIN is the name given to the transfer data.  
Depending on the values of the external constant, the specified gain may not be output.

[5] Graphic Equalizer f3 / f4

GAIN	D40	D41	D42	D43	D44	D45	D46	D47
+12dB	1	1	1	1	GREQ SELECT 0 : f3 1 : f4	0	1	0
+12dB	0	1	1	1				
+10dB	1	0	1	1				
+8dB	0	0	1	1				
+6dB	1	1	0	1				
+4dB	0	1	0	1				
+2dB	1	0	0	1				
0dB	0	0	0	1				
0dB	0	0	0	0				
-2dB	1	0	0	0				
-4dB	0	1	0	0				
-6dB	1	1	0	0				
-8dB	0	0	1	0				
-10dB	1	0	1	0				
-12dB	0	1	1	0				
-12dB	1	1	1	0				

Note : GAIN is the name given to the transfer data.  
Depending on the values of the external constant, the specified gain may not be output.

Audio ICs

[6] Graphic Equalizer f5, DPL

GAIN	D50	D51	D52	D53	D54	D55	D56	D57
+12dB	1	1	1	1	DPL SELECT 0 : OFF 1 : ON	1	1	0
+12dB	0	1	1	1				
+10dB	1	0	1	1				
+8dB	0	0	1	1				
+6dB	1	1	0	1				
+4dB	0	1	0	1				
+2dB	1	0	0	1				
0dB	0	0	0	1				
0dB	0	0	0	0				
-2dB	1	0	0	0				
-4dB	0	1	0	0				
-6dB	1	1	0	0				
-8dB	0	0	1	0				
-10dB	1	0	1	0				
-12dB	0	1	1	0				
-12dB	1	1	1	0				

Note : GAIN is the name given to the transfer data.  
Depending on the values of the external constant, the specified gain may not be output.

[7] Input Selector, Dynamic Bass / Biamp, Surround / Simulated stereo

INPUT	D60	D61	D62	D63	D64	D65	D66	D67
MUTE	0	0	0	0 : Surround 1 : Simulated stereo	0 : Dynamic Bass 1 : Biamp	0	0	1
INPUT-LA, INPUT-RA	1	0	0					
INPUT-LB, INPUT-RB	0	1	0					
INPUT-LC, INPUT-RC	1	1	0					
MUTE	0	0	1					
MUTE	1	0	1					
INPUT-LD1, INPUT-RD1 (0dB)	0	1	1					
INPUT-LD2, INPUT-RD2 (-9dB)	1	1	1					

[8] Spectrum Analyzer

FREQUENCY	D70	D71	D72	D73	D74	D75	D76	D77
RESET	0	0	0	*	*	1	1	1
RESET	1	0	0					
fo=105Hz	0	1	0					
fo=340Hz	1	1	0					
fo=1kHz	0	0	1					
fo=3.4kHz	1	0	1					
fo=10.5kHz	0	1	1					
Priority over parallel data	1	1	1					

\* Don't Care

Audio ICs

---

## PARALLEL CONTROL

A 36pin	B 37pin	C 38pin	BPOUT (39pin)
0	0	0	RESET
0	0	1	105Hz
0	1	0	340Hz
0	1	1	RESET
1	0	0	1kHz
1	0	1	RESET
1	1	0	3.4kHz
1	1	1	10.5kHz

When serial control is done, a parallel control isn't received.

When the serial control is "parallel priority", a parallel control on the left is received.

When changing the frequency of spectrum analyzer, transmit the command of the following frequency after transmitting a reset command.

Audio ICs

● Application example

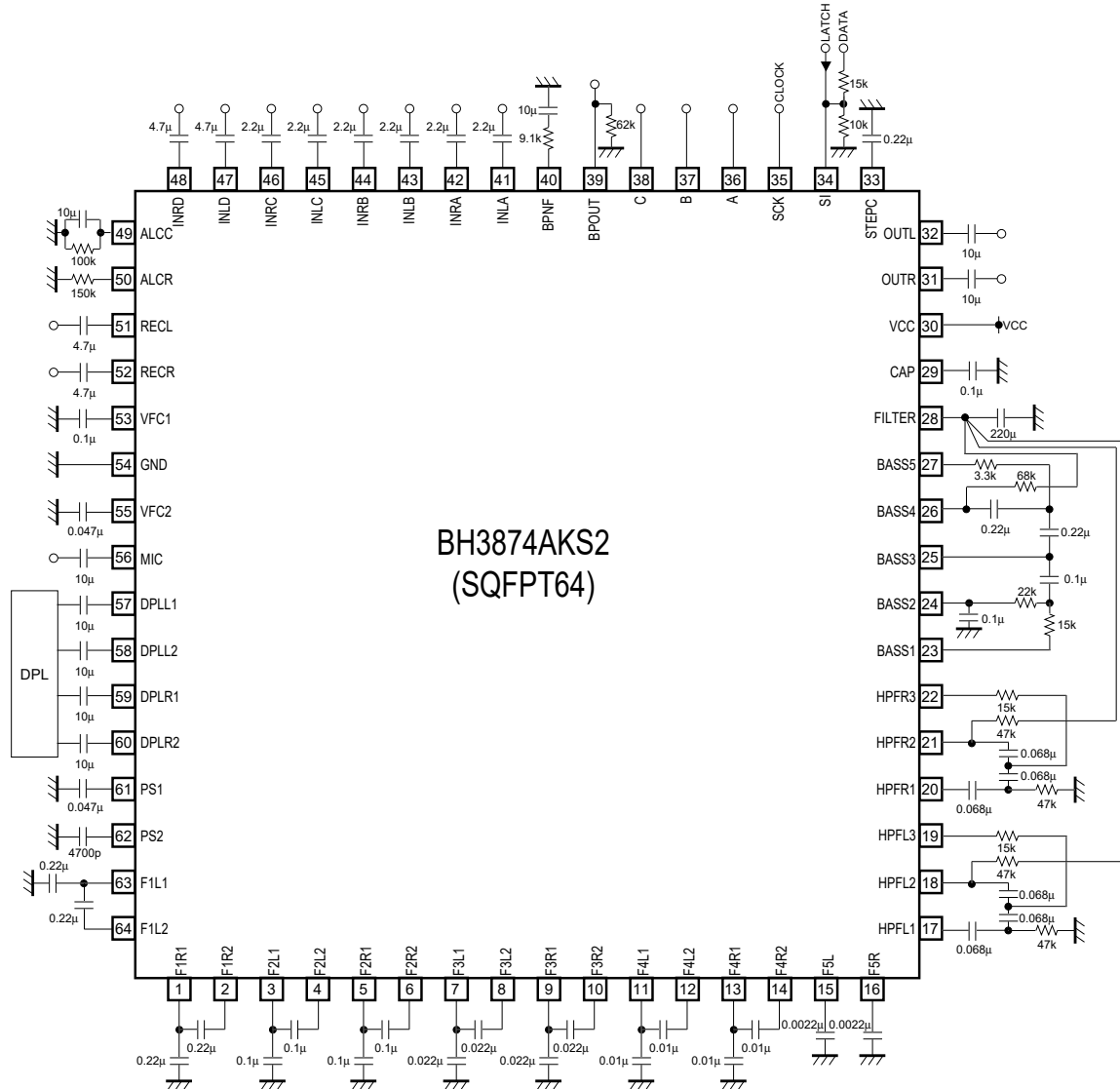

Fig.4

Audio ICs

●Operation notes

- (1) About operation voltage supply range  
 Within operation voltage supply range, basic circuit function operation is guaranteed within operation ambient temp. But please confirm set up constant and element, voltage set up and temp set up on use.
- (2) About operation temp range.  
 If it within recommended operation voltage range, circuit function operation is guaranteed within operation temp. It corralled to conditions of power dissipation to temp.  
 Please watch out except condition stipulated by electrical characteristics within the range. It cannot guarantee standard value of electrical characteristics. But it retains original function.
- (3) About Application circuit  
 Example of application circuit drawing is convinced as recommendable. But please confirm characteristic including above mentioned noticed.  
 At use with modification of external constant, please decide with enough margin considering distribution, ETC of this IC, external parts including quiescence characteristics and excessive characteristics.  
 Please note that we have not yet confirmed any concerned patent rights completely.
- (4) About 2-wire serial control  
 High-frequency digital signal is inputted into the SCK terminal and SI terminal. So wire and print patterns suitably to prevent interference to analog signal system line (especially to input line).
- (5) About ground line  
 Please connect IC's ground to the ground of a set with one point. When the IC has common impedance to the ground line, pop noise may occur in function switching.
- (6) About Schmidt circuit  
 This IC has the Schmidt circuit as preventive measures against logic signal input into the DATA (34pin) and CLK (35pin) terminals. Therefore, this IC is not affected so much by noise to a logic signal line.
- (7) About power on/off  
 At on of power supply or off of power supply pop noise occurs. Therefore, please supply mute.
- (8) Setting of spectrum analyzer minimum light level  
 Output offset voltage may shift due to the surrounding conditions (temperature, stresses, etc.).  
 Therefore when setting the spectrum analyzer minimum light level, leave a margin (more than 30% to spectrum analyzer output offset voltage VOS).

●Electrical characteristic curves

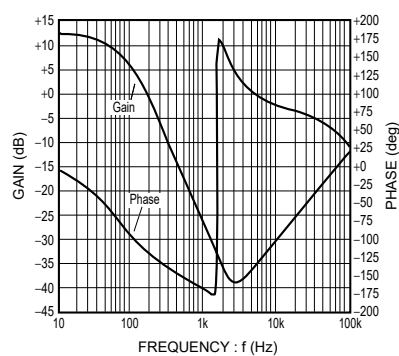

Fig.5 Vocal fade characteristics

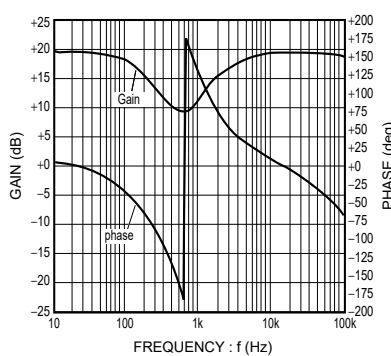

Fig.6 Surround characteristics

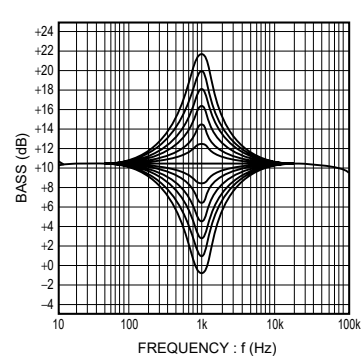

Fig.7 Graphic equalizer characteristics

Audio ICs

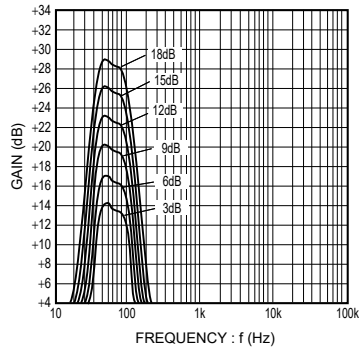

Fig.8 Biamp characteristics (Input common-mode)

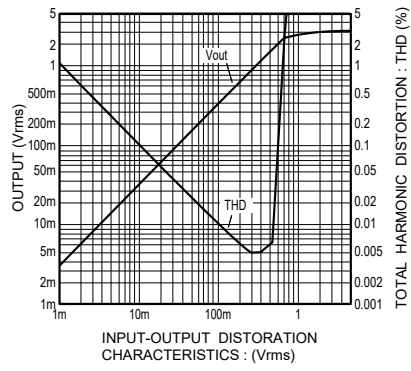

Fig.9 Input-output distortion characteristics

●External dimensions (Units : mm)

