

DESCRIPTION

The MP1523 is a 5-pin SOT23 step-up converter designed for driving up to six (6) series white LEDs from a single-cell Lithium Ion battery. The MP1523 uses a current limited, variable frequency architecture to regulate the LED current, which is measured through an external current sense resistor. Its low 0.4V feedback threshold reduces power loss and improves efficiency. To prevent damage due to an open circuit condition, the BIAS pin can measure the output voltage and turn off the converter if an over-voltage condition is present.

The MP1523 includes under-voltage lockout, current limiting, and thermal overload protection to prevent damage in the event of an output overload. The MP1523 is available in a small 5-pin SOT23 package.

FEATURES

- On Board Power MOSFET
- Drives up to 6 White LEDs
- Up to 90% Efficiency
- Over 80mA Output Current Capacity
- Open Load Shutdown
- Low 0.4V Feedback Threshold
- UVLO, Thermal Shutdown
- Soft-Start
- Internal Current Limiter
- Available in SOT23-5 Package
- Evaluation Board Available

APPLICATIONS

- Cell Phones
- Handheld Computers and PDAs
- Digital Still and Video Cameras
- Small LCD Displays

MPS, "MPS", "Monolithic Power Systems", and "The Future of Analog IC Technology" are Registered Trademarks of Monolithic Power Systems, Inc.

TYPICAL APPLICATION

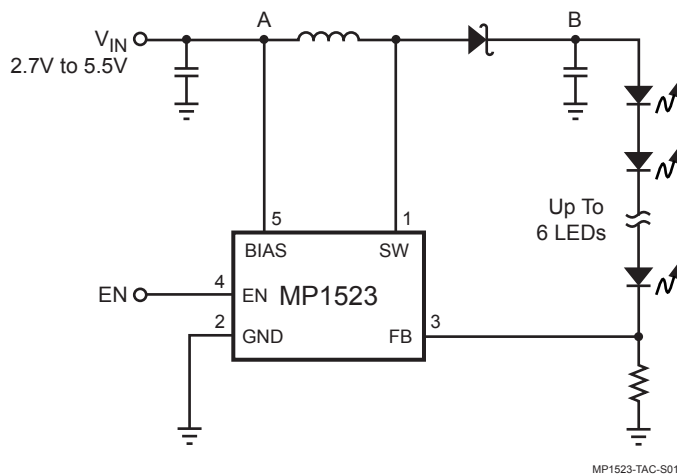

Efficiency vs LED Current
6 LEDs Using a Toko D62CB 47μH Inductor

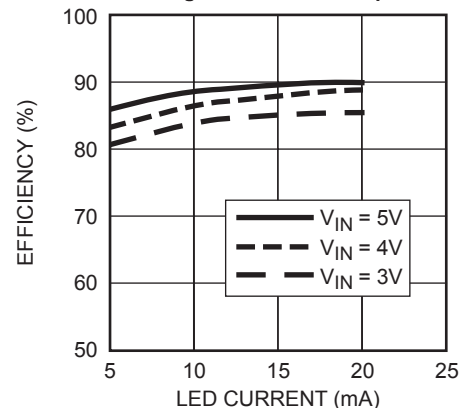

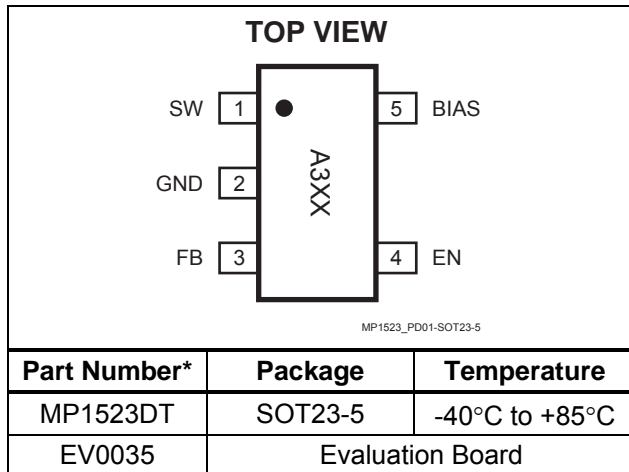
PACKAGE REFERENCE

* For Tape & Reel, add suffix -Z (eg. MP1523DT-Z)
 For Lead Free, add suffix -LF (eg. MP1523DT-LF-Z)

ABSOLUTE MAXIMUM RATINGS ⁽¹⁾

BIAS -0.3V to 28V
 SW -0.5V to 28V
 All Other Pins -0.3V to 6V
 Storage Temperature -55°C to +150°C

Recommended Operating Conditions ⁽²⁾

BIAS Supply Voltage 2.7V to 25V
 Output Voltage V_{IN} to 25V
 Operating Temperature -40°C to +85°C

Thermal Resistance ⁽³⁾

Θ_{JA} (SOT23-5) 220°C/W
 Θ_{JC} (SOT23-5) 110°C/W

Notes:

- Exceeding these ratings may damage the device.
- The device is not guaranteed to function outside of its operating conditions.
- Measured on approximately 1" square of 1 oz copper.

ELECTRICAL CHARACTERISTICS ⁽⁴⁾

$V_{BIAS} = V_{EN} = 5.0V$, $T_A = 25^\circ C$, unless otherwise noted.

Parameter	Symbol	Condition	Min	Typ	Max	Units
Supply Current (shutdown)	$I_{BIAS(OFF)}$	$V_{EN} = 0V$		1	3	μA
Supply Current (quiescent)	$I_{BIAS(ON)}$	$V_{FB} = 0.45V$		650	750	μA
Minimum Off Time, Normal Operation	T_{OFF}	$V_{FB} = 0V$	300	550	700	ns
Minimum Off Time, Start-Up	T_{OFF}	$V_{FB} = 0V^{(4)}$	1.25	1.6		μs
Undervoltage Lockout						
BIAS Under Voltage Lockout	UVLO	V_{BIAS} Rising, 100mV Hysteresis	2.1	2.3	2.65	V
Open Lamp Shutdown Threshold		V_{BIAS} Rising		28		V
Enable						
EN Threshold		V_{EN} Rising	0.8	1.1	1.5	V
EN Hysteresis				60		mV
EN Input Bias Current		$V_{EN} = 0V, 5V$			1	μA
Feedback Comparator						
FB Regulation Threshold		V_{FB} Falling	380	400	420	mV
FB Hysteresis ⁽⁵⁾				10		mV
FB Input Bias Current		$V_{FB} = 0.2V$	-150	-80		nA
Output Switch						
SW On-Resistance ⁽⁵⁾	R_{ON}			0.5	0.6	Ω
SW Current Limit			300	450	650	mA
SW Voltage	BV	$I_{SW} = 10\mu A$	25			V
Thermal Shutdown ⁽⁵⁾				160		$^\circ C$
Thermal Shutdown Hysteresis ⁽⁵⁾				15		$^\circ C$

Notes:

- First 64 pulses after EN switches high.
- Guaranteed by design.

TYPICAL PERFORMANCE CHARACTERISTICS

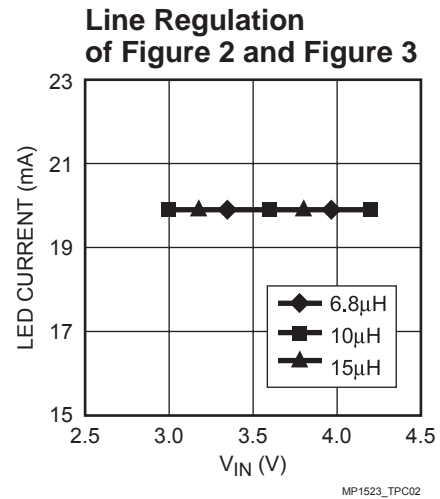
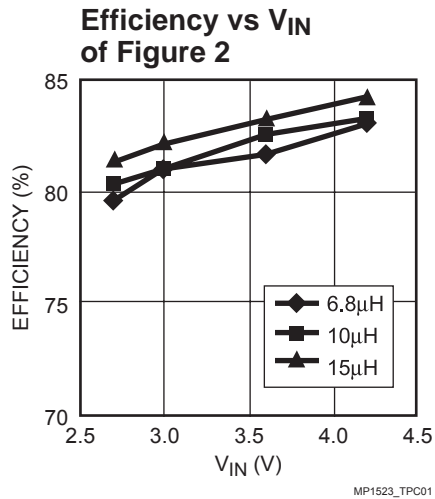

PIN FUNCTIONS

Pin #	Name	Description
1	SW	Power Switch Output. SW is the drain of the internal MOSFET switch. Connect the power inductor and output rectifier to SW. SW can swing between GND and 25V.
2	GND	Ground
3	FB	Feedback Input. The MP1523 regulates the voltage across the current sense resistor between FB and GND. Connect a current sense resistor from the bottom of the LED string to GND. Connect the bottom of the LED string to FB. The regulation threshold is 0.4V.
4	EN	Regulator On/Off Control Input. A high input at EN turns on the converter, and a low input turns it off. When not used, connect EN to the input source for automatic startup. If EN is driven over 6V, place a resistor in series with EN to limit current to 10µA or less. Do not leave EN floating!
5	BIAS	Internal Power Input. BIAS powers the internal circuitry and measures the output voltage for open circuit protection. Connect BIAS to the output at the top of the LED string to enable open load shutdown feature (see Figure 3). Connect BIAS to the input to eliminate open load shutdown feature (see Figure 2).

OPERATION

The MP1523 is a step-up converter that operates from an input voltage as low as 2.7V and generates an output voltage up to 25V. The 0.5Ω internal N-Channel power MOSFET is driven with a variable frequency, constant-peak-current architecture for low operating current. The 550ns minimum off time is extended to 1.6μs during start-up to yield a smooth glitch free turn-on.

Variable Frequency Constant-Peak-Current Operation

When the power MOSFET is turned on the inductor current increases until the 0.45A current limit is reached. The internal power MOSFET is then turned off for a minimum of 550ns. At the end of this 550ns transition if the FB pin is still lower than the 400mV threshold the MOSFET will again be turned on, otherwise

the MP1523 waits until the voltage drops below the threshold before turning on the MOSFET again. This process allows for optimal use of the inductor, while minimizing the output ripple and size of the output capacitor and maintaining low operating current.

Open Load Shutdown

Open load shutdown is implemented by connecting the BIAS pin to the output. In the fault condition where the connection to the LED string is open, the output voltage will rise up, as the FB pin has no voltage. Once the output voltage exceeds 28V, the MP1523 will cease operation until the EN pin is cycled off and on. Connecting the BIAS pin to V_{IN} disables open load shutdown but reduces the chip power consumption due to the quiescent current.

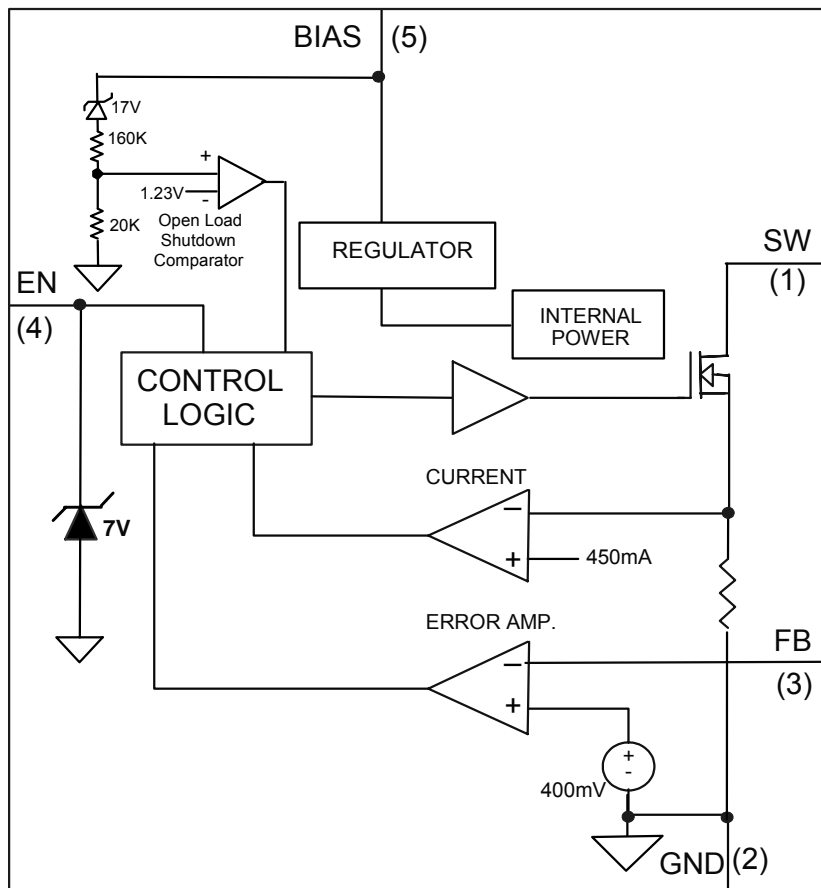

Figure 1—Functional Block Diagram

APPLICATIONS INFORMATION

Setting the LED current

The LED current is set by the sense resistor (R2) at FB. The LED current can be calculated as:

$$I_{LED} = \frac{V_{FB}}{R2}$$

Where V_{FB} is 400mV. The LED current is set to 20mA if $R2 = 20\Omega$.

Capacitor Selection

A 1 μ F to 10 μ F ceramic input capacitor (C1) and a 0.47 μ F to 1 μ F ceramic output capacitor (C2) are recommended for most applications. A capacitor (typically 1nF) in parallel with the LED string improves stability, input and output ripple especially when large inductance values (10 μ H or above) are used. For best stability over a wide temperature range, use capacitors with an X5R or X7R dielectric.

Inductor selection

The MP1523 has a 450mA inductor current limit and can drive up to 6 LEDs at 20mA. Inductance values (L1) from 4.7 μ H to 47 μ H work satisfactorily. Larger values provide the best efficiency while small inductor values allow the smallest inductor size. To prevent

saturation, use an inductor with a saturation current rating that matches the device current limit.

Diode selection

The MP1523's high switching frequency demands a high-speed rectifier (D1) for optimum efficiency. A schottky diode is recommended due to its fast recovery time and low forward voltage drop. Ensure the diode's average and peak current ratings exceed the average output current and peak inductor current. In addition, the diode's reverse breakdown voltage must exceed the output voltage.

Layout

Careful PC board layout is required due to fast-switching. All components must be placed as close to the IC as possible. Keep the path between inductor L1, diode D1, and output capacitor C2 extremely short for minimal noise and ringing. The feedback components such as sense resistor R2 must be kept close to the FB pin to prevent noise injection on the FB pin trace. The ground return of C1 and C2 should be tied close to the GND pin. See the MP1523 demo board layout for reference.

TYPICAL APPLICATIONS / TEST CIRCUITS

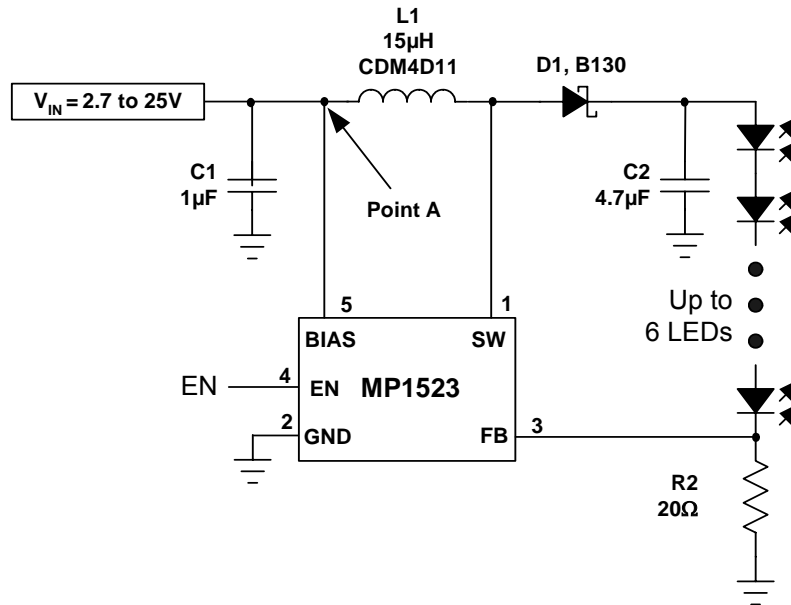

Note: Pin 5 connects to Point A to eliminate Open Load Shutdown Option

Figure 2—One String of up to Six (6) LEDs “without” Open Load Shutdown Option

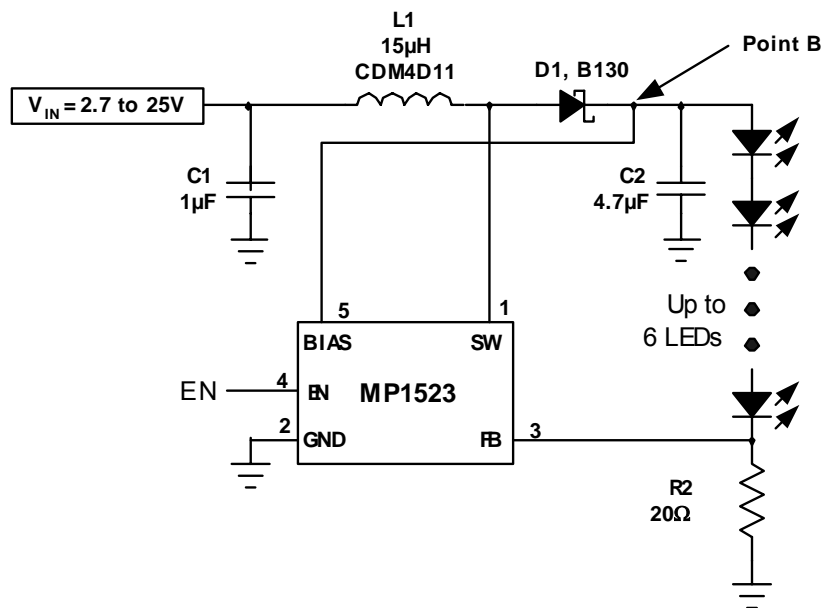

Note: Pin 5 connects to Point B to enable Open Load Shutdown Option

Figure 3—One String of up to Six (6) LEDs “with” Open Load Shutdown Option

PACKAGE INFORMATION

SOT23-5

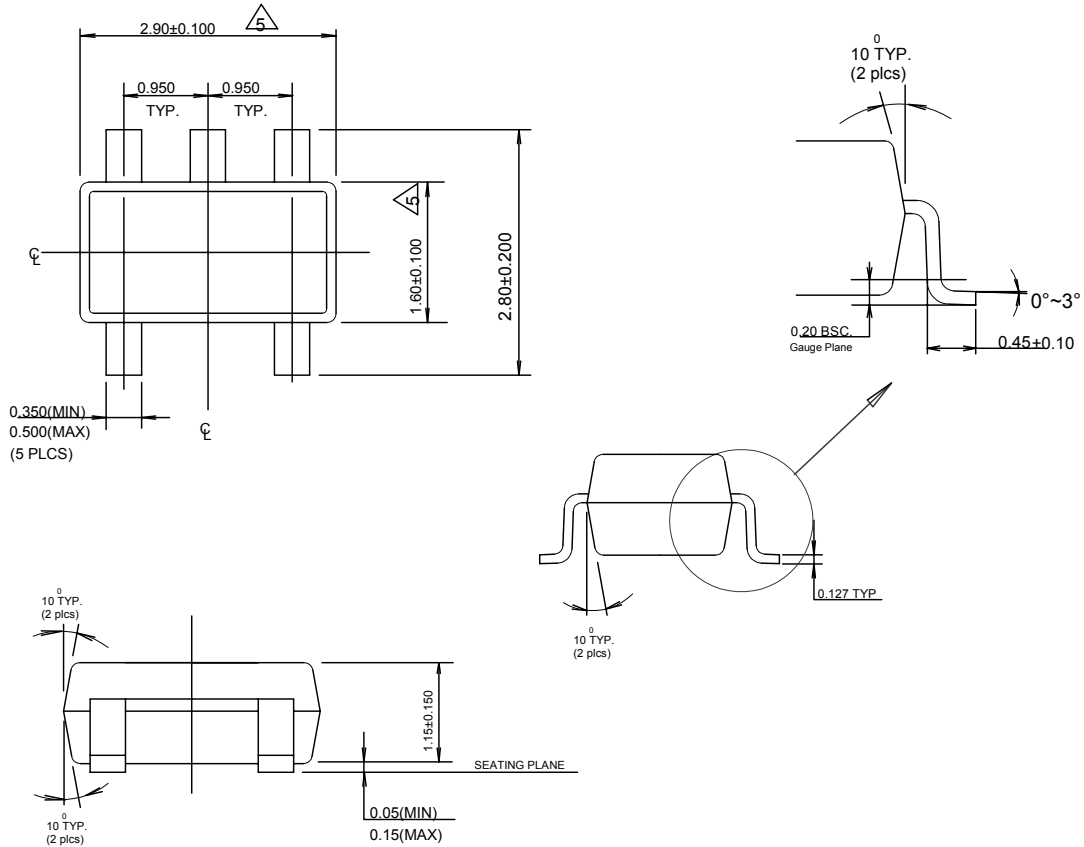

NOTICE: MPS believes the information in this document to be accurate and reliable. However, it is subject to change without notice. Contact MPS for current specifications. MPS encourages users of its products to ensure that third party Intellectual Property rights are not infringed upon when integrating MPS products into any application. MPS cannot assume any legal responsibility for any said applications.