

# CC2650 SimpleLink™ Multistandard Wireless MCU

## 1 Device Overview

### 1.1 Features

- Microcontroller
  - Powerful ARM® Cortex®-M3
  - EEMBC CoreMark® Score: 142
  - Up to 48-MHz Clock Speed
  - 128KB of In-System Programmable Flash
  - 8KB of SRAM for Cache
  - 20KB of Ultralow-Leakage SRAM
  - 2-Pin cJTAG and JTAG Debugging
  - Supports Over-The-Air Upgrade (OTA)
- Ultralow-Power Sensor Controller
  - Can Run Autonomous From the Rest of the System
  - 16-Bit Architecture
  - 2KB of Ultralow-Leakage SRAM for Code and Data
- Efficient Code Size Architecture, Placing Drivers, Bluetooth® Low Energy Controller, IEEE 802.15.4 MAC, and Bootloader in ROM
- RoHS-Compliant Packages
  - 4-mm × 4-mm RSM VQFN32 (10 GPIOs)
  - 5-mm × 5-mm RHB VQFN32 (15 GPIOs)
  - 7-mm × 7-mm RGZ VQFN48 (31 GPIOs)
- Peripherals
  - All Digital Peripheral Pins Can Be Routed to Any GPIO
  - Four General-Purpose Timer Modules (Eight 16-Bit or Four 32-Bit Timers, PWM Each)
  - 12-Bit ADC, 200-ksamples/s, 8-Channel Analog MUX
  - Continuous Time Comparator
  - Ultralow-Power Analog Comparator
  - Programmable Current Source
  - UART
  - 2× SSI (SPI, MICROWIRE, TI)
  - I2C
  - I2S
  - Real-Time Clock (RTC)
  - AES-128 Security Module
  - True Random Number Generator (TRNG)
  - 10, 15, or 31 GPIOs, Depending on Package Option
  - Support for Eight Capacitive-Sensing Buttons
  - Integrated Temperature Sensor
- External System
  - On-Chip internal DC-DC Converter
  - Very Few External Components
  - Seamless Integration With the SimpleLink™ CC2590 and CC2592 Range Extenders
  - Pin Compatible With the SimpleLink CC13xx in 4-mm × 4-mm and 5-mm × 5-mm VQFN Packages
- Low Power
  - Wide Supply Voltage Range
    - Normal Operation: 1.8 to 3.8 V
    - External Regulator Mode: 1.7 to 1.95 V
  - Active-Mode RX: 5.9 mA
  - Active-Mode TX at 0 dBm: 6.1 mA
  - Active-Mode TX at +5 dBm: 9.1 mA
  - Active-Mode MCU: 61 µA/MHz
  - Active-Mode MCU: 48.5 CoreMark/mA
  - Active-Mode Sensor Controller: 8.2 µA/MHz
  - Standby: 1 µA (RTC Running and RAM/CPU Retention)
  - Shutdown: 100 nA (Wake Up on External Events)
- RF Section
  - 2.4-GHz RF Transceiver Compatible With Bluetooth Low Energy (BLE) 4.1 Specification and IEEE 802.15.4 PHY and MAC
  - Excellent Receiver Sensitivity (–97 dBm for BLE and –100 dBm for 802.15.4), Selectivity, and Blocking Performance
  - Link budget of 102 dB/105 dB (BLE/802.15.4)
  - Programmable Output Power up to +5 dBm
  - Single-Ended or Differential RF Interface
  - Suitable for Systems Targeting Compliance With Worldwide Radio Frequency Regulations
    - ETSI EN 300 328 (Europe)
    - EN 300 440 Class 2 (Europe)
    - FCC CFR47 Part 15 (US)
    - ARIB STD-T66 (Japan)
- Tools and Development Environment
  - Full-Feature and Low-Cost Development Kits
  - Multiple Reference Designs for Different RF Configurations
  - Packet Sniffer PC Software
  - Sensor Controller Studio
  - SmartRF™ Studio
  - SmartRF Flash Programmer 2
  - IAR Embedded Workbench® for ARM
  - Code Composer Studio™



## 1.2 Applications

- Consumer Electronics
- Mobile Phone Accessories
- Sports and Fitness Equipment
- HID Applications
- Home and Building Automation
- Lighting Control
- Alarm and Security
- Electronic Shelf Labeling
- Proximity Tags
- Medical
- Remote Controls
- Wireless Sensor Networks

## 1.3 Description

The CC2650 device is a wireless MCU targeting *Bluetooth* Smart, ZigBee<sup>®</sup> and 6LoWPAN, and ZigBee RF4CE remote control applications.

The device is a member of the CC26xx family of cost-effective, ultralow power, 2.4-GHz RF devices. Very low active RF and MCU current and low-power mode current consumption provide excellent battery lifetime and allow for operation on small coin cell batteries and in energy-harvesting applications.

The CC2650 device contains a 32-bit ARM Cortex-M3 processor that runs at 48 MHz as the main processor and a rich peripheral feature set that includes a unique ultralow power sensor controller. This sensor controller is ideal for interfacing external sensors and for collecting analog and digital data autonomously while the rest of the system is in sleep mode. Thus, the CC2650 device is ideal for applications within a whole range of products including industrial, consumer electronics, and medical.

The *Bluetooth* Low Energy controller and the IEEE 802.15.4 MAC are embedded into ROM and are partly running on a separate ARM Cortex-M0 processor. This architecture improves overall system performance and power consumption and frees up flash memory for the application.

The *Bluetooth* Smart and ZigBee stacks are available free of charge from [www.ti.com](http://www.ti.com).

### Device Information<sup>(1)</sup>

| PART NUMBER   | PACKAGE   | BODY SIZE (NOM)   |
|---------------|-----------|-------------------|
| CC2650F128RGZ | VQFN (48) | 7.00 mm × 7.00 mm |
| CC2650F128RHB | VQFN (32) | 5.00 mm × 5.00 mm |
| CC2650F128RSM | VQFN (32) | 4.00 mm × 4.00 mm |

(1) For more information, see [Section 9, Mechanical Packaging and Orderable Information](#).

### 1.4 Functional Block Diagram

Figure 1-1 shows a block diagram for the CC2650.

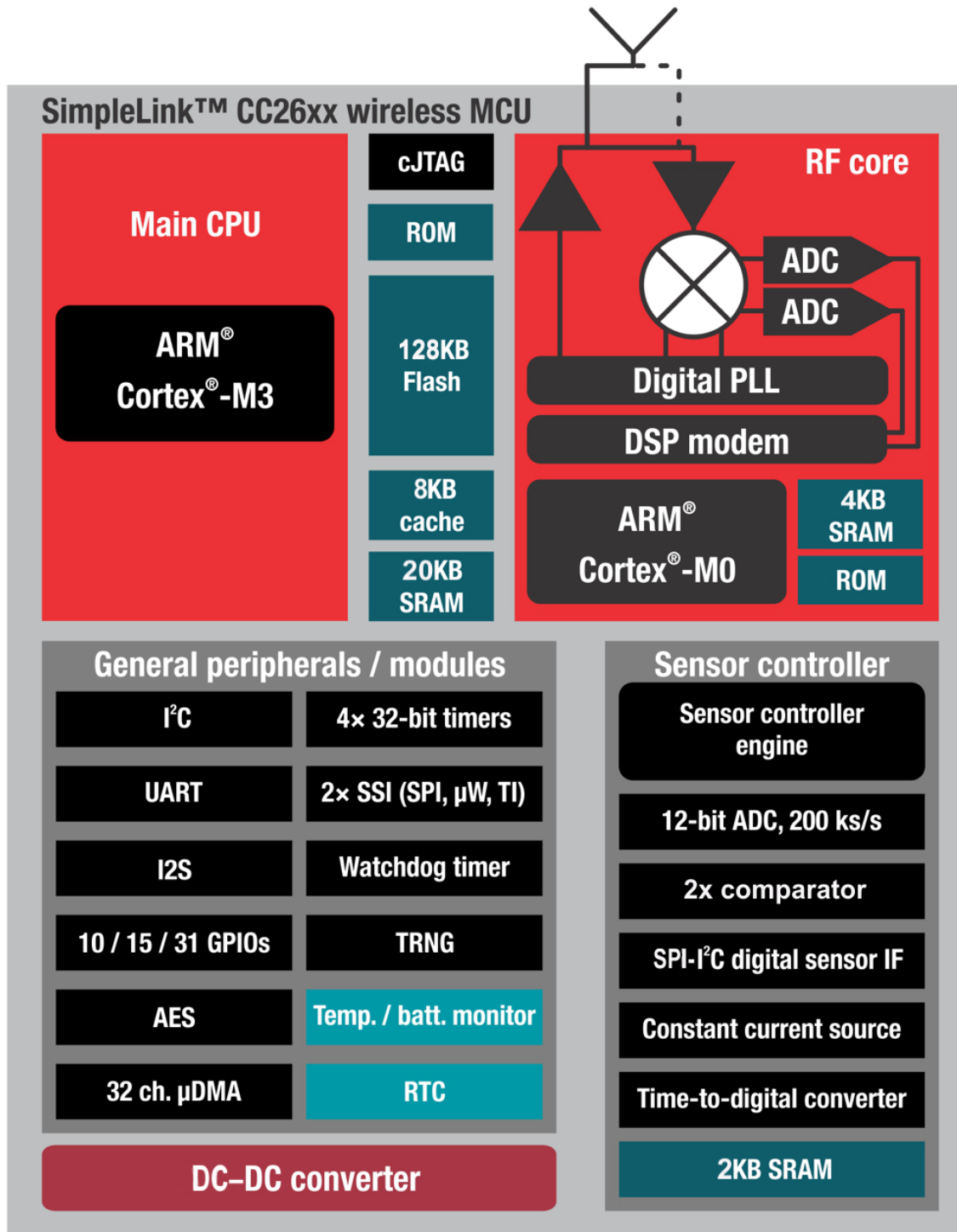

Figure 1-1. Block Diagram

## Table of Contents

|          |  |           |          |   |           |
|----------|--|-----------|----------|---|-----------|
| <b>1</b> | <b>Device Overview</b>                           | <b>1</b>  | 5.22     | Timing Requirements                                   | <b>22</b> |
| 1.1      | Features   | <b>1</b>  | 5.23     | Switching Characteristics                             | <b>22</b> |
| 1.2      | Applications                                     | <b>2</b>  | 5.24     | Typical Characteristics                               | <b>24</b> |
| 1.3      | Description                                      | <b>2</b>  | <b>6</b> | <b>Detailed Description</b>                           | <b>29</b> |
| 1.4      | Functional Block Diagram                         | <b>3</b>  | 6.1      | Overview  | <b>29</b> |
| <b>2</b> | <b>Revision History</b>                          | <b>5</b>  | 6.2      | Functional Block Diagram                              | <b>29</b> |
| <b>3</b> | <b>Device Comparison</b>                         | <b>6</b>  | 6.3      | Main CPU  | <b>30</b> |
| <b>4</b> | <b>Terminal Configuration and Functions</b>      | <b>7</b>  | 6.4      | RF Core   | <b>30</b> |
| 4.1      | Pin Diagram – RGZ Package                        | <b>7</b>  | 6.5      | Sensor Controller                                     | <b>31</b> |
| 4.2      | Signal Descriptions – RGZ Package                | <b>7</b>  | 6.6      | Memory  | <b>32</b> |
| 4.3      | Pin Diagram – RHB Package                        | <b>9</b>  | 6.7      | Debug   | <b>32</b> |
| 4.4      | Signal Descriptions – RHB Package                | <b>9</b>  | 6.8      | Power Management                                      | <b>33</b> |
| 4.5      | Pin Diagram – RSM Package                        | <b>11</b> | 6.9      | Clock Systems   | <b>34</b> |
| 4.6      | Signal Descriptions – RSM Package                | <b>11</b> | 6.10     | General Peripherals and Modules                       | <b>34</b> |
| <b>5</b> | <b>Specifications</b>                            | <b>13</b> | 6.11     | System Architecture                                   | <b>35</b> |
| 5.1      | Absolute Maximum Ratings                         | <b>13</b> | <b>7</b> | <b>Application, Implementation, and Layout</b>        | <b>36</b> |
| 5.2      | ESD Ratings                                      | <b>13</b> | 7.1      | Application Information                               | <b>36</b> |
| 5.3      | Recommended Operating Conditions                 | <b>13</b> | 7.2      | 5 × 5 External Differential (5XD) Application Circuit | <b>38</b> |
| 5.4      | Power Consumption Summary                        | <b>14</b> | 7.3      | 4 × 4 External Single-ended (4XS) Application Circuit | <b>40</b> |
| 5.5      | General Characteristics                          | <b>14</b> | <b>8</b> | <b>Device and Documentation Support</b>               | <b>42</b> |
| 5.6      | 1-Mbps GFSK ( <i>Bluetooth</i> Low Energy) – RX  | <b>15</b> | 8.1      | Device Support  | <b>42</b> |
| 5.7      | 1-Mbps GFSK ( <i>Bluetooth</i> Low Energy) – TX  | <b>16</b> | 8.2      | Documentation Support                                 | <b>44</b> |
| 5.8      | IEEE 802.15.4 (Offset Q-PSK DSSS, 250 kbps) – RX | <b>16</b> | 8.3      | Community Resources                                   | <b>44</b> |
| 5.9      | IEEE 802.15.4 (Offset Q-PSK DSSS, 250 kbps) – TX | <b>17</b> | 8.4      | Texas Instruments Low-Power RF Website                | <b>44</b> |
| 5.10     | 24-MHz Crystal Oscillator (XOSC_HF)              | <b>17</b> | 8.5      | Low-Power RF Online Community                         | <b>44</b> |
| 5.11     | 32.768-kHz Crystal Oscillator (XOSC_LF)          | <b>17</b> | 8.6      | Texas Instruments Low-Power RF Developer Network      | <b>44</b> |
| 5.12     | 48-MHz RC Oscillator (RCOSC_HF)                  | <b>18</b> | 8.7      | Low-Power RF eNewsletter                              | <b>44</b> |
| 5.13     | 32-kHz RC Oscillator (RCOSC_LF)                  | <b>18</b> | 8.8      | Additional Information                                | <b>45</b> |
| 5.14     | ADC Characteristics                              | <b>18</b> | 8.9      | Trademarks  | <b>45</b> |
| 5.15     | Temperature Sensor                               | <b>19</b> | 8.10     | Electrostatic Discharge Caution                       | <b>45</b> |
| 5.16     | Battery Monitor                                  | <b>19</b> | 8.11     | Export Control Notice                                 | <b>45</b> |
| 5.17     | Continuous Time Comparator                       | <b>19</b> | 8.12     | Glossary  | <b>45</b> |
| 5.18     | Low-Power Clocked Comparator                     | <b>20</b> | <b>9</b> | <b>Mechanical Packaging and Orderable Information</b> | <b>45</b> |
| 5.19     | Programmable Current Source                      | <b>20</b> | 9.1      | Packaging Information                                 | <b>45</b> |
| 5.20     | DC Characteristics                               | <b>20</b> |          |   |           |
| 5.21     | Thermal Characteristics                          | <b>21</b> |          |   |           |

## 2 Revision History

NOTE: Page numbers for previous revisions may differ from page numbers in the current version.

| <b>Changes from February 21, 2015 to October 15, 2015</b>                                     | <b>Page</b>        |
|---|--------------------|
| • Removed RHB package option from CC2620 .....  | <a href="#">6</a>  |
| • Added motional inductance recommendation to the 24-MHz XOSC table .....                     | <a href="#">17</a> |
| • Added VOH and VOL min and max values for 4-mA and 8-mA load .....                           | <a href="#">20</a> |
| • Added min and max values for VIH and VIL .....  | <a href="#">21</a> |
| • Added SPI timing parameters .....   | <a href="#">22</a> |
| • Added <i>IEEE 802.15.4 Sensitivity vs Channel Frequency</i> .....                           | <a href="#">24</a> |
| • Added <i>BLE Sensitivity vs Channel Frequency</i> .....                                     | <a href="#">24</a> |
| • Added <i>RF Output Power vs Channel Frequency</i> .....                                     | <a href="#">24</a> |
| • Added <i>Receive Mode Current vs Supply Voltage (VDDS)</i> graph .....                      | <a href="#">24</a> |
| • Changed SoC ADC ENOB vs Sampling Frequency (Input Frequency = FS / 10) graph .....          | <a href="#">26</a> |
| • Clarified Brown Out Detector status and functionality in the <i>Power Modes</i> table. .... | <a href="#">33</a> |
| • Added application circuit schematics and layout for 5XD and 4XS .....                       | <a href="#">36</a> |

### 3 Device Comparison

**Table 3-1. Device Family Overview**

| DEVICE        | PHY SUPPORT                          | FLASH (KB) | RAM (KB) | GPIO       | PACKAGE <sup>(1)</sup> |
|---------------|--------------------------------------|------------|----------|------------|------------------------|
| CC2650F128xxx | Multi-Protocol <sup>(2)</sup>        | 128        | 20       | 31, 15, 10 | RGZ, RHB, RSM          |
| CC2640F128xxx | <i>Bluetooth</i> low energy          | 128        | 20       | 31, 15, 10 | RGZ, RHB, RSM          |
| CC2630F128xxx | IEEE 802.15.4 Zigbee/ <i>6LoWPAN</i> | 128        | 20       | 31, 15, 10 | RGZ, RHB, RSM          |
| CC2620F128xxx | IEEE 802.15.4 (RF4CE)                | 128        | 20       | 31, 10     | RGZ, RSM               |

(1) Package designator replaces the xxx in device name to form a complete device name, RGZ is 7-mm × 7-mm VQFN48, RHB is 5-mm × 5-mm VQFN32, and RSM is 4-mm × 4-mm VQFN32.

(2) The CC2650 device supports all PHYs and can be reflashed to run all the supported standards.

## 4 Terminal Configuration and Functions

### 4.1 Pin Diagram – RGZ Package

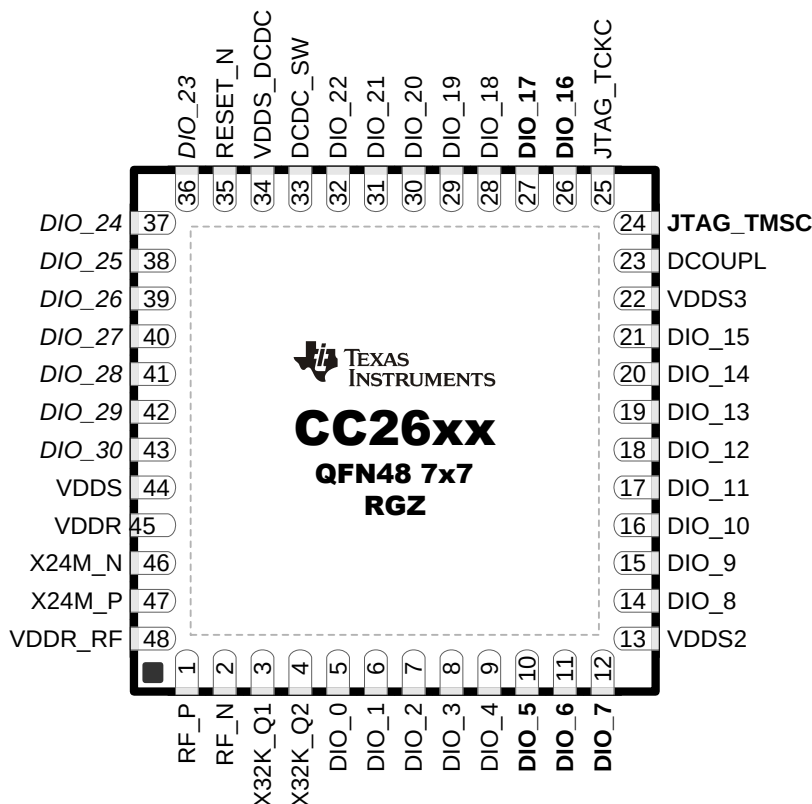

Note: I/O pins marked in **bold** have high drive capabilities. I/O pins marked in *italics* have analog capabilities.

Figure 4-1. RGZ (7-mm × 7-mm) Pinout, 0.5-mm Pitch

### 4.2 Signal Descriptions – RGZ Package

Table 4-1. Signal Descriptions – RGZ Package

| NAME    | NO. | TYPE        | DESCRIPTION   |
|---------|-----|-------------|---|
| DCDC_SW | 33  | Power       | Output from internal DC-DC <sup>(1)</sup>                           |
| DCOUP_L | 23  | Power       | 1.27-V regulated digital-supply decoupling capacitor <sup>(2)</sup> |
| DIO_0   | 5   | Digital I/O | GPIO, Sensor Controller   |
| DIO_1   | 6   | Digital I/O | GPIO, Sensor Controller   |
| DIO_2   | 7   | Digital I/O | GPIO, Sensor Controller   |
| DIO_3   | 8   | Digital I/O | GPIO, Sensor Controller   |
| DIO_4   | 9   | Digital I/O | GPIO, Sensor Controller   |
| DIO_5   | 10  | Digital I/O | GPIO, Sensor Controller, high-drive capability                      |
| DIO_6   | 11  | Digital I/O | GPIO, Sensor Controller, high-drive capability                      |
| DIO_7   | 12  | Digital I/O | GPIO, Sensor Controller, high-drive capability                      |
| DIO_8   | 14  | Digital I/O | GPIO  |
| DIO_9   | 15  | Digital I/O | GPIO  |
| DIO_10  | 16  | Digital I/O | GPIO  |
| DIO_11  | 17  | Digital I/O | GPIO  |

(1) See Section 8.2, technical reference manual for more details.

(2) Do not supply external circuitry from this pin.

**Table 4-1. Signal Descriptions – RGZ Package (continued)**

| NAME      | NO. | TYPE               | DESCRIPTION   |
|-----------|-----|--------------------|---|
| DIO_12    | 18  | Digital I/O        | GPIO  |
| DIO_13    | 19  | Digital I/O        | GPIO  |
| DIO_14    | 20  | Digital I/O        | GPIO  |
| DIO_15    | 21  | Digital I/O        | GPIO  |
| DIO_16    | 26  | Digital I/O        | GPIO, JTAG_TDO, high-drive capability   |
| DIO_17    | 27  | Digital I/O        | GPIO, JTAG_TDI, high-drive capability   |
| DIO_18    | 28  | Digital I/O        | GPIO  |
| DIO_19    | 29  | Digital I/O        | GPIO  |
| DIO_20    | 30  | Digital I/O        | GPIO  |
| DIO_21    | 31  | Digital I/O        | GPIO  |
| DIO_22    | 32  | Digital I/O        | GPIO  |
| DIO_23    | 36  | Digital/Analog I/O | GPIO, Sensor Controller, Analog   |
| DIO_24    | 37  | Digital/Analog I/O | GPIO, Sensor Controller, Analog   |
| DIO_25    | 38  | Digital/Analog I/O | GPIO, Sensor Controller, Analog   |
| DIO_26    | 39  | Digital/Analog I/O | GPIO, Sensor Controller, Analog   |
| DIO_27    | 40  | Digital/Analog I/O | GPIO, Sensor Controller, Analog   |
| DIO_28    | 41  | Digital/Analog I/O | GPIO, Sensor Controller, Analog   |
| DIO_29    | 42  | Digital/Analog I/O | GPIO, Sensor Controller, Analog   |
| DIO_30    | 43  | Digital/Analog I/O | GPIO, Sensor Controller, Analog   |
| JTAG_TMSC | 24  | Digital I/O        | JTAG TMSC, high-drive capability  |
| JTAG_TCKC | 25  | Digital I/O        | JTAG TCKC   |
| RESET_N   | 35  | Digital input      | Reset, active-low. No internal pullup.  |
| RF_P      | 1   | RF I/O             | Positive RF input signal to LNA during RX<br>Positive RF output signal to PA during TX              |
| RF_N      | 2   | RF I/O             | Negative RF input signal to LNA during RX<br>Negative RF output signal to PA during TX              |
| VDDR      | 45  | Power              | 1.7-V to 1.95-V supply, typically connect to output of internal DC-DC <sup>(3)</sup> <sup>(2)</sup> |
| VDDR_RF   | 48  | Power              | 1.7-V to 1.95-V supply, typically connect to output of internal DC-DC <sup>(4)</sup> <sup>(2)</sup> |
| VDDS      | 44  | Power              | 1.8-V to 3.8-V main chip supply <sup>(1)</sup>  |
| VDDS2     | 13  | Power              | 1.8-V to 3.8-V DIO supply <sup>(1)</sup>  |
| VDDS3     | 22  | Power              | 1.8-V to 3.8-V DIO supply <sup>(1)</sup>  |
| VDDS_DCDC | 34  | Power              | 1.8-V to 3.8-V DC-DC supply   |
| X32K_Q1   | 3   | Analog I/O         | 32-kHz crystal oscillator pin 1   |
| X32K_Q2   | 4   | Analog I/O         | 32-kHz crystal oscillator pin 2   |
| X24M_N    | 46  | Analog I/O         | 24-MHz crystal oscillator pin 1   |
| X24M_P    | 47  | Analog I/O         | 24-MHz crystal oscillator pin 2   |
| EGP       |     | Power              | Ground – Exposed Ground Pad   |

(3) If internal DC-DC is not used, this pin is supplied internally from the main LDO.

(4) If internal DC-DC is not used, this pin must be connected to VDDR for supply from the main LDO.



### 4.3 Pin Diagram – RHB Package

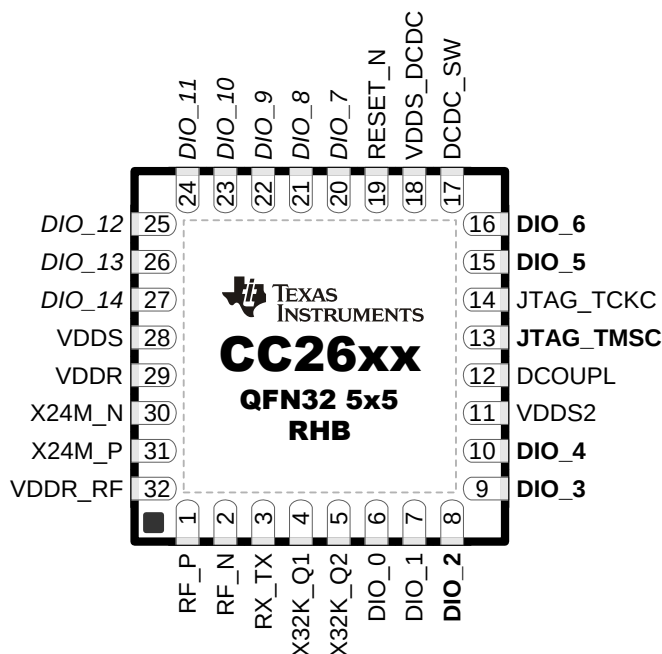

Note: I/O pins marked in **bold** have high drive capabilities. I/O pins marked in *italics* have analog capabilities.

Figure 4-2. RHB (5-mm × 5-mm) Pinout, 0.5-mm Pitch

### 4.4 Signal Descriptions – RHB Package

Table 4-2. Signal Descriptions – RHB Package

| NAME      | NO. | TYPE               | DESCRIPTION   |
|-----------|-----|--------------------|---|
| DCDC_SW   | 17  | Power              | Output from internal DC-DC <sup>(1)</sup>                 |
| DCOUPL    | 12  | Power              | 1.27-V regulated digital-supply decoupling <sup>(2)</sup> |
| DIO_0     | 6   | Digital I/O        | GPIO, Sensor Controller                                   |
| DIO_1     | 7   | Digital I/O        | GPIO, Sensor Controller                                   |
| DIO_2     | 8   | Digital I/O        | GPIO, Sensor Controller, high-drive capability            |
| DIO_3     | 9   | Digital I/O        | GPIO, Sensor Controller, high-drive capability            |
| DIO_4     | 10  | Digital I/O        | GPIO, Sensor Controller, high-drive capability            |
| DIO_5     | 15  | Digital I/O        | GPIO, High drive capability, JTAG_TDO                     |
| DIO_6     | 16  | Digital I/O        | GPIO, High drive capability, JTAG_TDI                     |
| DIO_7     | 20  | Digital/Analog I/O | GPIO, Sensor Controller, Analog                           |
| DIO_8     | 21  | Digital/Analog I/O | GPIO, Sensor Controller, Analog                           |
| DIO_9     | 22  | Digital/Analog I/O | GPIO, Sensor Controller, Analog                           |
| DIO_10    | 23  | Digital/Analog I/O | GPIO, Sensor Controller, Analog                           |
| DIO_11    | 24  | Digital/Analog I/O | GPIO, Sensor Controller, Analog                           |
| DIO_12    | 25  | Digital/Analog I/O | GPIO, Sensor Controller, Analog                           |
| DIO_13    | 26  | Digital/Analog I/O | GPIO, Sensor Controller, Analog                           |
| DIO_14    | 27  | Digital/Analog I/O | GPIO, Sensor Controller, Analog                           |
| JTAG_TMSC | 13  | Digital I/O        | JTAG TMSC, high-drive capability                          |
| JTAG_TCKC | 14  | Digital I/O        | JTAG TCKC   |
| RESET_N   | 19  | Digital input      | Reset, active-low. No internal pullup.                    |

(1) See Section 8.2, technical reference manual for more details.

(2) Do not supply external circuitry from this pin.

**Table 4-2. Signal Descriptions – RHB Package (continued)**

| NAME      | NO. | TYPE       | DESCRIPTION  |
|-----------|-----|------------|--|
| RF_N      | 2   | RF I/O     | Negative RF input signal to LNA during RX<br>Negative RF output signal to PA during TX   |
| RF_P      | 1   | RF I/O     | Positive RF input signal to LNA during RX<br>Positive RF output signal to PA during TX   |
| RX_TX     | 3   | RF I/O     | Optional bias pin for the RF LNA   |
| VDDR      | 29  | Power      | 1.7-V to 1.95-V supply, typically connect to output of internal DC-DC <sup>(3)</sup> (2) |
| VDDR_RF   | 32  | Power      | 1.7-V to 1.95-V supply, typically connect to output of internal DC-DC <sup>(4)</sup> (2) |
| VDDS      | 28  | Power      | 1.8-V to 3.8-V main chip supply <sup>(1)</sup>   |
| VDDS2     | 11  | Power      | 1.8-V to 3.8-V GPIO supply <sup>(1)</sup>  |
| VDDS_DCDC | 18  | Power      | 1.8-V to 3.8-V DC-DC supply  |
| X32K_Q1   | 4   | Analog I/O | 32-kHz crystal oscillator pin 1  |
| X32K_Q2   | 5   | Analog I/O | 32-kHz crystal oscillator pin 2  |
| X24M_N    | 30  | Analog I/O | 24-MHz crystal oscillator pin 1  |
| X24M_P    | 31  | Analog I/O | 24-MHz crystal oscillator pin 2  |
| EGP       |     | Power      | Ground – Exposed Ground Pad  |

(3) If internal DC-DC is not used, this pin is supplied internally from the main LDO.

(4) If internal DC-DC is not used, this pin must be connected to VDDR for supply from the main LDO.

### 4.5 Pin Diagram – RSM Package

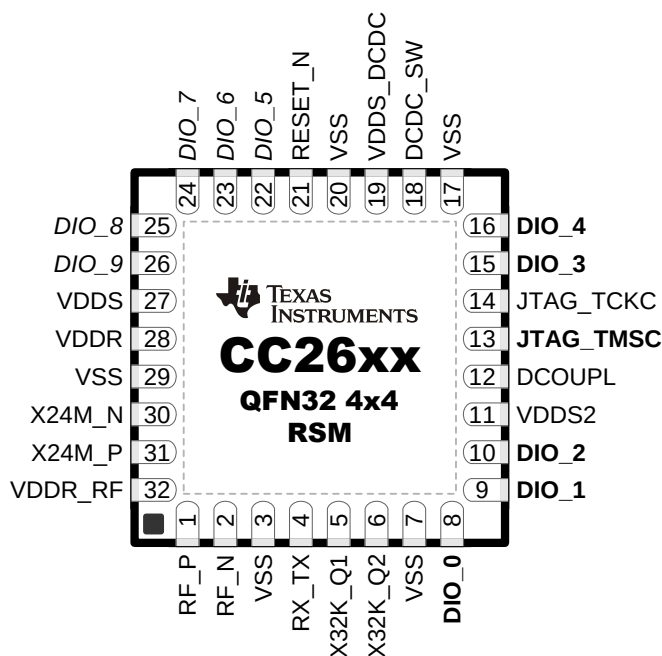

Note: I/O pins marked in **bold** have high drive capabilities. I/O pins marked in *italics* have analog capabilities.

Figure 4-3. RSM (4-mm × 4-mm) Pinout, 0.4-mm Pitch

### 4.6 Signal Descriptions – RSM Package

Table 4-3. Signal Descriptions – RSM Package

| NAME      | NO. | TYPE               | DESCRIPTION  |
|-----------|-----|--------------------|--|
| DCDC_SW   | 18  | Power              | Output from internal DC-DC. <sup>(1)</sup> Tie to ground for external regulator mode (1.7-V to 1.95-V operation) |
| DCOUPL    | 12  | Power              | 1.27-V regulated digital-supply decoupling capacitor <sup>(2)</sup>  |
| DIO_0     | 8   | Digital I/O        | GPIO, Sensor Controller, high-drive capability   |
| DIO_1     | 9   | Digital I/O        | GPIO, Sensor Controller, high-drive capability   |
| DIO_2     | 10  | Digital I/O        | GPIO, Sensor Controller, high-drive capability   |
| DIO_3     | 15  | Digital I/O        | GPIO, High drive capability, JTAG_TDO  |
| DIO_4     | 16  | Digital I/O        | GPIO, High drive capability, JTAG_TDI  |
| DIO_5     | 22  | Digital/Analog I/O | GPIO, Sensor Controller, Analog  |
| DIO_6     | 23  | Digital/Analog I/O | GPIO, Sensor Controller, Analog  |
| DIO_7     | 24  | Digital/Analog I/O | GPIO, Sensor Controller, Analog  |
| DIO_8     | 25  | Digital/Analog I/O | GPIO, Sensor Controller, Analog  |
| DIO_9     | 26  | Digital/Analog I/O | GPIO, Sensor Controller, Analog  |
| JTAG_TMSC | 13  | Digital I/O        | JTAG TMSC  |
| JTAG_TCKC | 14  | Digital I/O        | JTAG TCKC  |
| RESET_N   | 21  | Digital Input      | Reset, active-low. No internal pullup.   |
| RF_N      | 2   | RF I/O             | Negative RF input signal to LNA during RX<br>Negative RF output signal to PA during TX                           |
| RF_P      | 1   | RF I/O             | Positive RF input signal to LNA during RX<br>Positive RF output signal to PA during TX                           |
| RX_TX     | 4   | RF I/O             | Optional bias pin for the RF LNA   |

(1) See Section 8.2, technical reference manual for more details.

(2) Do not supply external circuitry from this pin.

**Table 4-3. Signal Descriptions – RSM Package (continued)**

| NAME      | NO.              | TYPE       | DESCRIPTION  |
|-----------|------------------|------------|--|
| VDDR      | 28               | Power      | 1.7-V to 1.95-V supply, typically connect to output of internal DC-DC. <sup>(3)</sup> <sup>(2)</sup> |
| VDDR_RF   | 32               | Power      | 1.7-V to 1.95-V supply, typically connect to output of internal DC-DC <sup>(4)</sup> <sup>(2)</sup>  |
| VDDS      | 27               | Power      | 1.8-V to 3.8-V main chip supply <sup>(1)</sup>   |
| VDDS2     | 11               | Power      | 1.8-V to 3.8-V GPIO supply <sup>(1)</sup>  |
| VDDS_DCDC | 19               | Power      | 1.8-V to 3.8-V DC-DC supply. Tie to ground for external regulator mode (1.7-V to 1.95-V operation).  |
| VSS       | 3, 7, 17, 20, 29 | Power      | Ground   |
| X32K_Q1   | 5                | Analog I/O | 32-kHz crystal oscillator pin 1  |
| X32K_Q2   | 6                | Analog I/O | 32-kHz crystal oscillator pin 2  |
| X24M_N    | 30               | Analog I/O | 24-MHz crystal oscillator pin 1  |
| X24M_P    | 31               | Analog I/O | 24-MHz crystal oscillator pin 2  |
| EGP       |                  | Power      | Ground – Exposed Ground Pad  |

(3) If internal DC-DC is not used, this pin is supplied internally from the main LDO.

(4) If internal DC-DC is not used, this pin must be connected to VDDR for supply from the main LDO.

## 5 Specifications

### 5.1 Absolute Maximum Ratings

over operating free-air temperature range (unless otherwise noted)<sup>(1) (2)</sup>

|   |   | MIN  | MAX                             | UNIT |
|---|---|------|---------------------------------|------|
| Supply voltage, VDD <sub>S</sub> <sup>(3)</sup>                         | VDDR supplied by internal DC-DC regulator or internal GLDO                | -0.3 | 4.1                             | V    |
| Supply voltage, VDD <sub>S</sub> <sup>(3)</sup> and VDDR                | External regulator mode (VDD <sub>S</sub> and VDDR pins connected on PCB) | -0.3 | 2.25                            | V    |
| Voltage on any digital pin <sup>(4)</sup>                               |   | -0.3 | VDD <sub>S</sub> + 0.3, max 4.1 | V    |
| Voltage on crystal oscillator pins, X32K_Q1, X32K_Q2, X24M_N and X24M_P |   | -0.3 | VDDR + 0.3, max 2.25            | V    |
| Voltage on ADC input (V <sub>in</sub> )                                 | Voltage scaling enabled   | -0.3 | VDD <sub>S</sub>                | V    |
|   | Voltage scaling disabled, internal reference                              | -0.3 | 1.49                            |      |
|   | Voltage scaling disabled, VDD <sub>S</sub> as reference                   | -0.3 | VDD <sub>S</sub> / 2.9          |      |
| Input RF level  |   |      | 5                               | dBm  |
| T <sub>stg</sub>  | Storage temperature   | -40  | 150                             | °C   |

(1) All voltage values are with respect to ground, unless otherwise noted.

(2) Stresses beyond those listed under *Absolute Maximum Ratings* may cause permanent damage to the device. These are stress ratings only, and functional operation of the device at these or any other conditions beyond those indicated under *Recommended Operating Conditions* is not implied. Exposure to absolute-maximum-rated conditions for extended periods may affect device reliability.

(3) VDD<sub>S2</sub> and VDD<sub>S3</sub> must be at the same potential as VDD<sub>S</sub>.

(4) Including analog-capable DIO.

### 5.2 ESD Ratings

|                  |   |  | VALUE       | UNIT  |   |
|------------------|---|--|-------------|-------|---|
| V <sub>ESD</sub> | Electrostatic discharge (ESD) performance | Human body model (HBM), per ANSI/ESDA/JEDEC JS001 <sup>(1)</sup> | All pins    | ±2500 | V |
|                  |   | Charged device model (CDM), per JESD22-C101 <sup>(2)</sup>       | RF pins     | ±750  |   |
|                  |   |  | Non-RF pins | ±750  |   |

(1) JEDEC document JEP155 states that 500-V HBM allows safe manufacturing with a standard ESD control process.

(2) JEDEC document JEP157 states that 250-V CDM allows safe manufacturing with a standard ESD control process.

### 5.3 Recommended Operating Conditions

over operating free-air temperature range (unless otherwise noted)

|   |   | MIN | MAX  | UNIT |
|---|---|-----|------|------|
| Ambient temperature range   |   | -40 | 85   | °C   |
| Operating supply voltage (VDD <sub>S</sub> and VDDR), external regulator mode | For operation in 1.8-V systems (VDD <sub>S</sub> and VDDR pins connected on PCB, internal DC-DC cannot be used) | 1.7 | 1.95 | V    |
| Operating supply voltage (VDD <sub>S</sub> )                                  | For operation in battery-powered and 3.3-V systems (internal DC-DC can be used to minimize power consumption)   | 1.8 | 3.8  | V    |

## 5.4 Power Consumption Summary

Measured on the TI CC2650EM-5XD reference design with  $T_c = 25^\circ\text{C}$ ,  $V_{\text{DD5}} = 3.0\text{ V}$  with internal DC-DC converter, unless otherwise noted.

| PARAMETER   |                          | TEST CONDITIONS   | MIN | TYP | MAX                                      | UNIT          |               |
|---|--------------------------|---|-----|-----|--|---------------|---------------|
| $I_{\text{core}}$   | Core current consumption | Reset. RESET_N pin asserted or VDD5 below Power-on-Reset threshold            |     | 100 |  | nA            |               |
|   |                          | Shutdown. No clocks running, no retention                                     |     | 150 |  |               |               |
|   |                          | Standby. With RTC, CPU, RAM and (partial) register retention. RCOSC_LF        |     |     | 1  |               | $\mu\text{A}$ |
|   |                          | Standby. With RTC, CPU, RAM and (partial) register retention. XOSC_LF         |     |     | 1.2                                      |               |               |
|   |                          | Standby. With Cache, RTC, CPU, RAM and (partial) register retention. RCOSC_LF |     |     | 2.5                                      |               |               |
|   |                          | Standby. With Cache, RTC, CPU, RAM and (partial) register retention. XOSC_LF  |     |     | 2.7                                      |               |               |
|   |                          | Idle. Supply Systems and RAM powered.   |     |     | 550                                      |               |               |
|   |                          | Active. Core running CoreMark   |     |     | 1.45 mA +<br>31 $\mu\text{A}/\text{MHz}$ |               |               |
|   |                          | Radio RX <sup>(1)</sup>   |     |     | 5.9                                      |               | mA            |
|   |                          | Radio RX <sup>(2)</sup>   |     |     | 6.1                                      |               |               |
|   |                          | Radio TX, 0-dBm output power <sup>(1)</sup>                                   |     |     | 6.1                                      |               |               |
|   |                          | Radio TX, 5-dBm output power <sup>(2)</sup>                                   |     |     | 9.1                                      |               |               |
| <b>Peripheral Current Consumption (Adds to core current <math>I_{\text{core}}</math> for each peripheral unit activated) <sup>(3)</sup></b> |                          |   |     |     |  |               |               |
| $I_{\text{peri}}$   | Peripheral power domain  | Delta current with domain enabled   |     | 20  |  | $\mu\text{A}$ |               |
|   | Serial power domain      | Delta current with domain enabled   |     | 13  |  | $\mu\text{A}$ |               |
|   | RF Core                  | Delta current with power domain enabled, clock enabled, RF core idle          |     | 237 |  | $\mu\text{A}$ |               |
|   | $\mu\text{DMA}$          | Delta current with clock enabled, module idle                                 |     | 130 |  | $\mu\text{A}$ |               |
|   | Timers                   | Delta current with clock enabled, module idle                                 |     | 113 |  | $\mu\text{A}$ |               |
|   | I <sup>2</sup> C         | Delta current with clock enabled, module idle                                 |     | 12  |  | $\mu\text{A}$ |               |
|   | I2S                      | Delta current with clock enabled, module idle                                 |     | 36  |  | $\mu\text{A}$ |               |
|   | SSI                      | Delta current with clock enabled, module idle                                 |     | 93  |  | $\mu\text{A}$ |               |
|   | UART                     | Delta current with clock enabled, module idle                                 |     | 164 |  | $\mu\text{A}$ |               |

(1) Single-ended RF mode is optimized for size and power consumption. Measured on CC2650EM-4XS.

(2) Differential RF mode is optimized for RF performance. Measured on CC2650EM-5XD.

(3)  $I_{\text{peri}}$  is not supported in Standby or Shutdown.

## 5.5 General Characteristics

Measured on the TI CC2650EM-5XD reference design with  $T_c = 25^\circ\text{C}$ ,  $V_{\text{DD5}} = 3.0\text{ V}$ , unless otherwise noted.

| PARAMETER                                   | TEST CONDITIONS                          | MIN | TYP  | MAX | UNIT          |
|---|--|-----|------|-----|---------------|
| <b>FLASH MEMORY</b>                         |  |     |      |     |               |
| Supported flash erase cycles before failure |  | 100 |      |     | k Cycles      |
| Flash page/sector erase current             | Average delta current                    |     | 12.6 |     | mA            |
| Flash page/sector size                      |  |     | 4    |     | KB            |
| Flash write current                         | Average delta current, 4 bytes at a time |     | 8.15 |     | mA            |
| Flash page/sector erase time <sup>(1)</sup> |  |     | 8    |     | ms            |
| Flash write time <sup>(1)</sup>             | 4 bytes at a time                        |     | 8    |     | $\mu\text{s}$ |

(1) This number is dependent on Flash aging and will increase over time and erase cycles.

## 5.6 1-Mbps GFSK (*Bluetooth Low Energy*) – RX

Measured on the TI CC2650EM-5XD reference design with  $T_c = 25^\circ\text{C}$ ,  $V_{\text{DD5}} = 3.0\text{ V}$ ,  $f_{\text{RF}} = 2440\text{ MHz}$ , unless otherwise noted.

| PARAMETER  | TEST CONDITIONS  | MIN  | TYP                    | MAX | UNIT |
|--|--|------|------------------------|-----|------|
| Receiver sensitivity   | Differential mode. Measured at the CC2650EM-5XD SMA connector, BER = $10^{-3}$   |      | -97                    |     | dBm  |
| Receiver sensitivity   | Single-ended mode. Measured on CC2650EM-4XS, at the SMA connector, BER = $10^{-3}$   |      | -96                    |     | dBm  |
| Receiver saturation  | Differential mode. Measured at the CC2650EM-5XD SMA connector, BER = $10^{-3}$   |      | 4                      |     | dBm  |
| Receiver saturation  | Single-ended mode. Measured on CC2650EM-4XS, at the SMA connector, BER = $10^{-3}$   |      | 0                      |     | dBm  |
| Frequency error tolerance                                      | Difference between the incoming carrier frequency and the internally generated carrier frequency   | -350 |                        | 350 | kHz  |
| Data rate error tolerance                                      | Difference between incoming data rate and the internally generated data rate   | -750 |                        | 750 | ppm  |
| Co-channel rejection <sup>(1)</sup>                            | Wanted signal at -67 dBm, modulated interferer in channel, BER = $10^{-3}$   |      | -6                     |     | dB   |
| Selectivity, $\pm 1\text{ MHz}$ <sup>(1)</sup>                 | Wanted signal at -67 dBm, modulated interferer at $\pm 1\text{ MHz}$ , BER = $10^{-3}$   |      | 7 / 3 <sup>(2)</sup>   |     | dB   |
| Selectivity, $\pm 2\text{ MHz}$ <sup>(1)</sup>                 | Wanted signal at -67 dBm, modulated interferer at $\pm 2\text{ MHz}$ , BER = $10^{-3}$   |      | 34 / 25 <sup>(2)</sup> |     | dB   |
| Selectivity, $\pm 3\text{ MHz}$ <sup>(1)</sup>                 | Wanted signal at -67 dBm, modulated interferer at $\pm 3\text{ MHz}$ , BER = $10^{-3}$   |      | 38 / 26 <sup>(2)</sup> |     | dB   |
| Selectivity, $\pm 4\text{ MHz}$ <sup>(1)</sup>                 | Wanted signal at -67 dBm, modulated interferer at $\pm 4\text{ MHz}$ , BER = $10^{-3}$   |      | 42 / 29 <sup>(2)</sup> |     | dB   |
| Selectivity, $\pm 5\text{ MHz}$ or more <sup>(1)</sup>         | Wanted signal at -67 dBm, modulated interferer at $\geq \pm 5\text{ MHz}$ , BER = $10^{-3}$  |      | 32                     |     | dB   |
| Selectivity, Image frequency <sup>(1)</sup>                    | Wanted signal at -67 dBm, modulated interferer at image frequency, BER = $10^{-3}$   |      | 25                     |     | dB   |
| Selectivity, Image frequency $\pm 1\text{ MHz}$ <sup>(1)</sup> | Wanted signal at -67 dBm, modulated interferer at $\pm 1\text{ MHz}$ from image frequency, BER = $10^{-3}$   |      | 3 / 26 <sup>(2)</sup>  |     | dB   |
| Out-of-band blocking <sup>(3)</sup>                            | 30 MHz to 2000 MHz   |      | -20                    |     | dBm  |
| Out-of-band blocking   | 2003 MHz to 2399 MHz   |      | -5                     |     | dBm  |
| Out-of-band blocking   | 2484 MHz to 2997 MHz   |      | -8                     |     | dBm  |
| Out-of-band blocking   | 3000 MHz to 12.75 GHz  |      | -8                     |     | dBm  |
| Intermodulation  | Wanted signal at 2402 MHz, -64 dBm. Two interferers at 2405 and 2408 MHz respectively, at the given power level  |      | -34                    |     | dBm  |
| Spurious emissions, 30 to 1000 MHz                             | Conducted measurement in a 50- $\Omega$ single-ended load. Suitable for systems targeting compliance with EN 300 328, EN 300 440 class 2, FCC CFR47, Part 15 and ARIB STD-T-66 |      | -71                    |     | dBm  |
| Spurious emissions, 1 to 12.75 GHz                             | Conducted measurement in a 50 $\Omega$ single-ended load. Suitable for systems targeting compliance with EN 300 328, EN 300 440 class 2, FCC CFR47, Part 15 and ARIB STD-T-66  |      | -62                    |     | dBm  |
| RSSI dynamic range   |  |      | 70                     |     | dB   |
| RSSI accuracy  |  |      | $\pm 4$                |     | dB   |

(1) Numbers given as I/C dB.

(2) X / Y, where X is +N MHz and Y is -N MHz.

(3) Excluding one exception at  $F_{\text{wanted}} / 2$ , per *Bluetooth* Specification.

## 5.7 1-Mbps GFSK (Bluetooth Low Energy) – TX

Measured on the TI CC2650EM-5XD reference design with  $T_c = 25^\circ\text{C}$ ,  $V_{\text{DD5}} = 3.0\text{ V}$ ,  $f_{\text{RF}} = 2440\text{ MHz}$ , unless otherwise noted.

| PARAMETER  | TEST CONDITIONS  | MIN | TYP | MAX | UNIT |
|--|--|-----|-----|-----|------|
| Output power, highest setting                          | Differential mode, delivered to a single-ended 50- $\Omega$ load through a balun |     | 5   |     | dBm  |
| Output power, highest setting                          | Measured on CC2650EM-4XS, delivered to a single-ended 50- $\Omega$ load          |     | 2   |     | dBm  |
| Output power, lowest setting                           | Delivered to a single-ended 50- $\Omega$ load through a balun                    |     | -21 |     | dBm  |
| Spurious emission conducted measurement <sup>(1)</sup> | $f < 1\text{ GHz}$ , outside restricted bands                                    |     | -43 |     | dBm  |
|  | $f < 1\text{ GHz}$ , restricted bands ETSI                                       |     | -65 |     | dBm  |
|  | $f < 1\text{ GHz}$ , restricted bands FCC  |     | -76 |     | dBm  |
|  | $f > 1\text{ GHz}$ , including harmonics   |     | -46 |     | dBm  |

(1) Suitable for systems targeting compliance with worldwide radio-frequency regulations ETSI EN 300 328 and EN 300 440 Class 2 (Europe), FCC CFR47 Part 15 (US), and ARIB STD-T66 (Japan).

## 5.8 IEEE 802.15.4 (Offset Q-PSK DSSS, 250 kbps) – RX

Measured on the TI CC2650EM-5XD reference design with  $T_c = 25^\circ\text{C}$ ,  $V_{\text{DD5}} = 3.0\text{ V}$ , unless otherwise noted.

| PARAMETER  | TEST CONDITIONS   | MIN | TYP  | MAX | UNIT |
|--|---|-----|------|-----|------|
| Receiver sensitivity                                       | Differential mode. Measured at the CC2650EM-5XD SMA connector, PER = 1%   |     | -100 |     | dBm  |
| Receiver sensitivity                                       | Single-ended mode. Measured on CC2650EM-4XS, at the SMA connector, PER = 1%   |     | -97  |     | dBm  |
| Receiver saturation  | Measured at the CC2650EM-5XD SMA connector, PER = 1%  |     | +4   |     | dBm  |
| Adjacent channel rejection                                 | Wanted signal at -82 dBm, modulated interferer at $\pm 5\text{ MHz}$ , PER = 1%   |     | 39   |     | dB   |
| Alternate channel rejection                                | Wanted signal at -82 dBm, modulated interferer at $\pm 10\text{ MHz}$ , PER = 1%  |     | 52   |     | dB   |
| Channel rejection, $\pm 15\text{ MHz}$ or more             | Wanted signal at -82 dBm, undesired signal is IEEE 802.15.4 modulated channel, stepped through all channels 2405 to 2480 MHz, PER = 1%  |     | 57   |     | dB   |
| Blocking and desensitization, 5 MHz from upper band edge   | Wanted signal at -97 dBm (3 dB above the sensitivity level), CW jammer, PER = 1%  |     | 64   |     | dB   |
| Blocking and desensitization, 10 MHz from upper band edge  | Wanted signal at -97 dBm (3 dB above the sensitivity level), CW jammer, PER = 1%  |     | 64   |     | dB   |
| Blocking and desensitization, 20 MHz from upper band edge  | Wanted signal at -97 dBm (3 dB above the sensitivity level), CW jammer, PER = 1%  |     | 65   |     | dB   |
| Blocking and desensitization, 50 MHz from upper band edge  | Wanted signal at -97 dBm (3 dB above the sensitivity level), CW jammer, PER = 1%  |     | 68   |     | dB   |
| Blocking and desensitization, -5 MHz from lower band edge  | Wanted signal at -97 dBm (3 dB above the sensitivity level), CW jammer, PER = 1%  |     | 63   |     | dB   |
| Blocking and desensitization, -10 MHz from lower band edge | Wanted signal at -97 dBm (3 dB above the sensitivity level), CW jammer, PER = 1%  |     | 63   |     | dB   |
| Blocking and desensitization, -20 MHz from lower band edge | Wanted signal at -97 dBm (3 dB above the sensitivity level), CW jammer, PER = 1%  |     | 65   |     | dB   |
| Blocking and desensitization, -50 MHz from lower band edge | Wanted signal at -97 dBm (3 dB above the sensitivity level), CW jammer, PER = 1%  |     | 67   |     | dB   |
| Spurious emissions, 30 MHz to 1000 MHz                     | Conducted measurement in a 50 $\Omega$ single-ended load. Suitable for systems targeting compliance with EN 300 328, EN 300 440 class 2, FCC CFR47, Part 15 and ARIB STD-T-66 |     | -71  |     | dBm  |
| Spurious emissions, 1 GHz to 12.75 GHz                     | Conducted measurement in a 50 $\Omega$ single-ended load. Suitable for systems targeting compliance with EN 300 328, EN 300 440 class 2, FCC CFR47, Part 15 and ARIB STD-T-66 |     | -62  |     | dBm  |
| Frequency error tolerance                                  | Difference between the incoming carrier frequency and the internally generated carrier frequency  |     | >200 |     | ppm  |



### IEEE 802.15.4 (Offset Q-PSK DSSS, 250 kbps) – RX (continued)

Measured on the TI CC2650EM-5XD reference design with  $T_c = 25^\circ\text{C}$ ,  $V_{\text{DDS}} = 3.0\text{ V}$ , unless otherwise noted.

| PARAMETER                   | TEST CONDITIONS  | MIN | TYP   | MAX | UNIT |
|-----------------------------|--|-----|-------|-----|------|
| Symbol rate error tolerance | Difference between incoming symbol rate and the internally generated symbol rate |     | >1000 |     | ppm  |
| RSSI dynamic range          |  |     | 100   |     | dB   |
| RSSI accuracy               |  |     | ±4    |     | dB   |

### 5.9 IEEE 802.15.4 (Offset Q-PSK DSSS, 250 kbps) – TX

Measured on the TI CC2650EM-5XD reference design with  $T_c = 25^\circ\text{C}$ ,  $V_{\text{DDS}} = 3.0\text{ V}$ , unless otherwise noted.

| PARAMETER                               | TEST CONDITIONS  | MIN | TYP | MAX | UNIT |
|---|--|-----|-----|-----|------|
| Output power, highest setting           | Delivered to a single-ended 50-Ω load through a balun  |     | 5   |     | dBm  |
| Output power, highest setting           | Measured on CC2650EM-4XS, delivered to a single-ended 50-Ω load  |     | 2   |     | dBm  |
| Output power, lowest setting            | Delivered to a single-ended 50-Ω load through a balun  |     | -21 |     | dBm  |
| Error vector magnitude                  | At maximum output power  |     | 2%  |     |      |
| Spurious emission conducted measurement | f < 1 GHz, outside restricted bands  |     | -43 |     | dBm  |
|   | f < 1 GHz, restricted bands ETSI   |     | -65 |     |      |
|   | f < 1 GHz, restricted bands FCC  |     | -76 |     |      |
|   | f > 1 GHz, including harmonics   |     | -46 |     |      |
|   | Suitable for systems targeting compliance with worldwide radio-frequency regulations ETSI EN 300 328 and EN 300 440 Class 2 (Europe), FCC CFR47 Part 15 (US), and ARIB STD-T66 (Japan) |     |     |     |      |

### 5.10 24-MHz Crystal Oscillator (XOSC\_HF)

Measured on the TI CC2650EM-5XD reference design with  $T_c = 25^\circ\text{C}$ ,  $V_{\text{DDS}} = 3.0\text{ V}$ , unless otherwise noted.<sup>(1)</sup>

| PARAMETER                                  | TEST CONDITIONS                                | MIN | TYP                             | MAX | UNIT |
|--|--|-----|---------------------------------|-----|------|
| ESR Equivalent series resistance           |  |     | 20                              | 60  | Ω    |
| $L_M$ Motional inductance                  | Relates to load capacitance ( $C_L$ in Farads) |     | $< 1.6 \times 10^{-24} / C_L^2$ |     | H    |
| $C_L$ Crystal load capacitance             |  | 5   |                                 | 9   | pF   |
| Crystal frequency                          |  |     | 24                              |     | MHz  |
| Crystal frequency tolerance <sup>(2)</sup> |  | -40 |                                 | 40  | ppm  |
| Start-up time <sup>(3)</sup>               |  |     | 150                             |     | μs   |

(1) Probing or otherwise stopping the XTAL while the DC-DC converter is enabled may cause permanent damage to the device.

(2) Includes initial tolerance of the crystal, drift over temperature, ageing and frequency pulling due to incorrect load capacitance. As per *Bluetooth* and IEEE 802.15.4 specification.

(3) Kick-started based on a temperature and aging compensated RCOSC\_HF using precharge injection.

### 5.11 32.768-kHz Crystal Oscillator (XOSC\_LF)

Measured on the TI CC2650EM-5XD reference design with  $T_c = 25^\circ\text{C}$ ,  $V_{\text{DDS}} = 3.0\text{ V}$ , unless otherwise noted.

| PARAMETER  | TEST CONDITIONS | MIN  | TYP    | MAX | UNIT |
|--|-----------------|------|--------|-----|------|
| Crystal frequency  |                 |      | 32.768 |     | kHz  |
| Crystal frequency tolerance, <i>Bluetooth</i> low-energy applications <sup>(1)</sup> |                 | -500 |        | 500 | ppm  |
| ESR Equivalent series resistance   |                 |      | 30     | 100 | kΩ   |
| $C_L$ Crystal load capacitance   |                 | 6    |        | 12  | pF   |

(1) Includes initial tolerance of the crystal, drift over temperature, ageing and frequency pulling due to incorrect load capacitance. As per *Bluetooth* and IEEE 802.15.4 specification.

## 5.12 48-MHz RC Oscillator (RCOSC\_HF)

Measured on the TI CC2650EM-5XD reference design with  $T_c = 25^\circ\text{C}$ ,  $V_{\text{DDS}} = 3.0\text{ V}$ , unless otherwise noted.

| PARAMETER                                    | TEST CONDITIONS | MIN | TYP          | MAX | UNIT          |
|--|-----------------|-----|--------------|-----|---------------|
| Frequency                                    |                 |     | 48           |     | MHz           |
| Uncalibrated frequency accuracy              |                 |     | $\pm 1\%$    |     |               |
| Calibrated frequency accuracy <sup>(1)</sup> |                 |     | $\pm 0.25\%$ |     |               |
| Start-up time                                |                 |     | 5            |     | $\mu\text{s}$ |

(1) Accuracy relative to the calibration source (XOSC\_HF).

## 5.13 32-kHz RC Oscillator (RCOSC\_LF)

Measured on the TI CC2650EM-5XD reference design with  $T_c = 25^\circ\text{C}$ ,  $V_{\text{DDS}} = 3.0\text{ V}$ , unless otherwise noted.

| PARAMETER               | TEST CONDITIONS | MIN | TYP  | MAX | UNIT                  |
|-------------------------|-----------------|-----|------|-----|-----------------------|
| Calibrated frequency    |                 |     | 32.8 |     | kHz                   |
| Temperature coefficient |                 |     | 50   |     | ppm/ $^\circ\text{C}$ |

## 5.14 ADC Characteristics

$T_c = 25^\circ\text{C}$ ,  $V_{\text{DDS}} = 3.0\text{ V}$  and voltage scaling enabled, unless otherwise noted.<sup>(1)</sup>

| PARAMETER           | TEST CONDITIONS                                    | MIN  | TYP     | MAX              | UNIT         |
|---------------------|--|--|---------|------------------|--------------|
| Input voltage range |  | 0  |         | V <sub>DDS</sub> | V            |
| Resolution          |  |  | 12      |                  | Bits         |
| Sample rate         |  |  |         | 200              | ksps         |
| Offset              | Internal 4.3-V equivalent reference <sup>(2)</sup> |  | 2       |                  | LSB          |
| Gain error          | Internal 4.3-V equivalent reference <sup>(2)</sup> |  | 2.4     |                  | LSB          |
| DNL <sup>(3)</sup>  | Differential nonlinearity                          |  | $> -1$  |                  | LSB          |
| INL <sup>(4)</sup>  | Integral nonlinearity                              |  | $\pm 3$ |                  | LSB          |
| ENOB                | Effective number of bits                           | Internal 4.3-V equivalent reference <sup>(2)</sup> , 200 ksps, 9.6-kHz input tone                    | 9.8     |                  | Bits         |
|                     |  | V <sub>DDS</sub> as reference, 200 ksps, 9.6-kHz input tone  | 10      |                  |              |
|                     |  | Internal 1.44-V reference, voltage scaling disabled, 32 samples average, 200 ksps, 300-Hz input tone | 11.1    |                  |              |
| THD                 | Total harmonic distortion                          | Internal 4.3-V equivalent reference <sup>(2)</sup> , 200 ksps, 9.6-kHz input tone                    | -65     |                  | dB           |
|                     |  | V <sub>DDS</sub> as reference, 200 ksps, 9.6-kHz input tone  | -69     |                  |              |
|                     |  | Internal 1.44-V reference, voltage scaling disabled, 32 samples average, 200 ksps, 300-Hz input tone | -71     |                  |              |
| SINAD, SNDR         | Signal-to-noise and Distortion ratio               | Internal 4.3-V equivalent reference <sup>(2)</sup> , 200 ksps, 9.6-kHz input tone                    | 60      |                  | dB           |
|                     |  | V <sub>DDS</sub> as reference, 200 ksps, 9.6-kHz input tone  | 63      |                  |              |
|                     |  | Internal 1.44-V reference, voltage scaling disabled, 32 samples average, 200 ksps, 300-Hz input tone | 69      |                  |              |
| SFDR                | Spurious-free dynamic range                        | Internal 4.3-V equivalent reference <sup>(2)</sup> , 200 ksps, 9.6-kHz input tone                    | 67      |                  | dB           |
|                     |  | V <sub>DDS</sub> as reference, 200 ksps, 9.6-kHz input tone  | 72      |                  |              |
|                     |  | Internal 1.44-V reference, voltage scaling disabled, 32 samples average, 200 ksps, 300-Hz input tone | 73      |                  |              |
| Conversion time     | Serial conversion, time-to-output, 24-MHz clock    |  | 50      |                  | clock-cycles |
| Current consumption | Internal 4.3-V equivalent reference <sup>(2)</sup> |  | 0.66    |                  | mA           |
| Current consumption | V <sub>DDS</sub> as reference                      |  | 0.75    |                  | mA           |

(1) Using IEEE Std 1241™-2010 for terminology and test methods.

(2) Input signal scaled down internally before conversion, as if voltage range was 0 to 4.3 V.

(3) No missing codes. Positive DNL typically varies from +0.3 to +3.5, depending on device (see [Figure 5-24](#)).

(4) For a typical example, see [Figure 5-25](#).

## ADC Characteristics (continued)

$T_c = 25^\circ\text{C}$ ,  $V_{\text{DDS}} = 3.0\text{ V}$  and voltage scaling enabled, unless otherwise noted.<sup>(1)</sup>

| PARAMETER         | TEST CONDITIONS   | MIN | TYP                        | MAX | UNIT |
|-------------------|---|-----|----------------------------|-----|------|
| Reference voltage | Equivalent fixed internal reference (input voltage scaling enabled)   |     | 4.3 <sup>(2) (5)</sup>     |     | V    |
| Reference voltage | Fixed internal reference (input voltage scaling disabled)   |     | 1.44 ±1%                   |     | V    |
| Reference voltage | VDDS as reference (Also known as <i>RELATIVE</i> ) (input voltage scaling enabled)                                    |     | VDDS                       |     | V    |
| Reference voltage | VDDS as reference (Also known as <i>RELATIVE</i> ) (input voltage scaling disabled)                                   |     | VDDS / 2.82 <sup>(5)</sup> |     | V    |
| Input Impedance   | 200 ksp/s, voltage scaling enabled. Capacitive input, Input impedance depends on sampling frequency and sampling time |     | >1                         |     | MΩ   |

(5) Applied voltage must be within absolute maximum ratings (Section 5.1) at all times.

### 5.15 Temperature Sensor

Measured on the TI CC2650EM-5XD reference design with  $T_c = 25^\circ\text{C}$ ,  $V_{\text{DDS}} = 3.0\text{ V}$ , unless otherwise noted.

| PARAMETER                                 | TEST CONDITIONS | MIN | TYP | MAX | UNIT |
|---|-----------------|-----|-----|-----|------|
| Resolution                                |                 |     | 4   |     | °C   |
| Range                                     |                 | -40 |     | 85  | °C   |
| Accuracy                                  |                 |     | ±5  |     | °C   |
| Supply voltage coefficient <sup>(1)</sup> |                 |     | 3.2 |     | °C/V |

(1) Automatically compensated when using supplied driver libraries.

### 5.16 Battery Monitor

Measured on the TI CC2650EM-5XD reference design with  $T_c = 25^\circ\text{C}$ ,  $V_{\text{DDS}} = 3.0\text{ V}$ , unless otherwise noted.

| PARAMETER  | TEST CONDITIONS | MIN | TYP | MAX | UNIT |
|------------|-----------------|-----|-----|-----|------|
| Resolution |                 |     | 50  |     | mV   |
| Range      |                 | 1.8 |     | 3.8 | V    |
| Accuracy   |                 |     | 13  |     | mV   |

### 5.17 Continuous Time Comparator

$T_c = 25^\circ\text{C}$ ,  $V_{\text{DDS}} = 3.0\text{ V}$ , unless otherwise noted.

| PARAMETER                                       | TEST CONDITIONS           | MIN | TYP  | MAX  | UNIT |
|---|---------------------------|-----|------|------|------|
| Input voltage range                             |                           | 0   |      | VDDS | V    |
| External reference voltage                      |                           | 0   |      | VDDS | V    |
| Internal reference voltage                      | DCOUPPL as reference      |     | 1.27 |      | V    |
| Offset  |                           |     | 3    |      | mV   |
| Hysteresis                                      |                           |     | <2   |      | mV   |
| Decision time                                   | Step from -10 mV to 10 mV |     | 0.72 |      | μs   |
| Current consumption when enabled <sup>(1)</sup> |                           |     | 8.6  |      | μA   |

(1) Additionally, the bias module must be enabled when running in standby mode.

## 5.18 Low-Power Clocked Comparator

$T_c = 25^\circ\text{C}$ ,  $V_{\text{DD5}} = 3.0\text{ V}$ , unless otherwise noted.

| PARAMETER  | TEST CONDITIONS           | MIN | TYP         | MAX              | UNIT        |
|--|---------------------------|-----|-------------|------------------|-------------|
| Input voltage range                              |                           | 0   |             | V <sub>DD5</sub> | V           |
| Clock frequency                                  |                           |     | 32          |                  | kHz         |
| Internal reference voltage, V <sub>DD5</sub> / 2 |                           |     | 1.49 – 1.51 |                  | V           |
| Internal reference voltage, V <sub>DD5</sub> / 3 |                           |     | 1.01 – 1.03 |                  | V           |
| Internal reference voltage, V <sub>DD5</sub> / 4 |                           |     | 0.78 – 0.79 |                  | V           |
| Internal reference voltage, DCOUPL / 1           |                           |     | 1.25 – 1.28 |                  | V           |
| Internal reference voltage, DCOUPL / 2           |                           |     | 0.63 – 0.65 |                  | V           |
| Internal reference voltage, DCOUPL / 3           |                           |     | 0.42 – 0.44 |                  | V           |
| Internal reference voltage, DCOUPL / 4           |                           |     | 0.33 – 0.34 |                  | V           |
| Offset   |                           |     | <2          |                  | mV          |
| Hysteresis                                       |                           |     | <5          |                  | mV          |
| Decision time                                    | Step from –50 mV to 50 mV |     | <1          |                  | clock-cycle |
| Current consumption when enabled                 |                           |     | 362         |                  | nA          |

## 5.19 Programmable Current Source

$T_c = 25^\circ\text{C}$ ,  $V_{\text{DD5}} = 3.0\text{ V}$ , unless otherwise noted.

| PARAMETER                                | TEST CONDITIONS   | MIN | TYP       | MAX | UNIT          |
|--|---|-----|-----------|-----|---------------|
| Current source programmable output range |   |     | 0.25 – 20 |     | $\mu\text{A}$ |
| Resolution                               |   |     | 0.25      |     | $\mu\text{A}$ |
| Current consumption <sup>(1)</sup>       | Including current source at maximum programmable output |     | 23        |     | $\mu\text{A}$ |

(1) Additionally, the bias module must be enabled when running in standby mode.

## 5.20 DC Characteristics

| PARAMETER  | TEST CONDITIONS   | MIN  | TYP  | MAX  | UNIT          |
|--|---|------|------|------|---------------|
| $T_A = 25^\circ\text{C}$ , $V_{\text{DD5}} = 1.8\text{ V}$ |   |      |      |      |               |
| GPIO VOH at 8-mA load                                      | IOCURR = 2, high-drive GPIOs only                                 | 1.32 | 1.54 |      | V             |
| GPIO VOL at 8-mA load                                      | IOCURR = 2, high-drive GPIOs only                                 |      | 0.26 | 0.32 | V             |
| GPIO VOH at 4-mA load                                      | IOCURR = 1  | 1.32 | 1.58 |      | V             |
| GPIO VOL at 4-mA load                                      | IOCURR = 1  |      | 0.21 | 0.32 | V             |
| GPIO pullup current  | Input mode, pullup enabled, V <sub>pad</sub> = 0 V                |      | 71.7 |      | $\mu\text{A}$ |
| GPIO pulldown current                                      | Input mode, pulldown enabled, V <sub>pad</sub> = V <sub>DD5</sub> |      | 21.1 |      | $\mu\text{A}$ |
| GPIO high/low input transition, no hysteresis              | IH = 0, transition between reading 0 and reading 1                |      | 0.88 |      | V             |
| GPIO low-to-high input transition, with hysteresis         | IH = 1, transition voltage for input read as 0 → 1                |      | 1.07 |      | V             |
| GPIO high-to-low input transition, with hysteresis         | IH = 1, transition voltage for input read as 1 → 0                |      | 0.74 |      | V             |
| GPIO input hysteresis                                      | IH = 1, difference between 0 → 1 and 1 → 0 points                 |      | 0.33 |      | V             |

**DC Characteristics (continued)**

| PARAMETER  | TEST CONDITIONS   | MIN | TYP  | MAX | UNIT                            |
|--|---|-----|------|-----|---------------------------------|
| <b>T<sub>A</sub> = 25°C, V<sub>DD5</sub> = 3.0 V</b> |   |     |      |     |                                 |
| GPIO VOH at 8-mA load                                | IOCURR = 2, high-drive GPIOs only                                 |     | 2.68 |     | V                               |
| GPIO VOL at 8-mA load                                | IOCURR = 2, high-drive GPIOs only                                 |     | 0.33 |     | V                               |
| GPIO VOH at 4-mA load                                | IOCURR = 1  |     | 2.72 |     | V                               |
| GPIO VOL at 4-mA load                                | IOCURR = 1  |     | 0.28 |     | V                               |
| <b>T<sub>A</sub> = 25°C, V<sub>DD5</sub> = 3.8 V</b> |   |     |      |     |                                 |
| GPIO pullup current                                  | Input mode, pullup enabled, V <sub>pad</sub> = 0 V                |     | 277  |     | μA                              |
| GPIO pulldown current                                | Input mode, pulldown enabled, V <sub>pad</sub> = V <sub>DD5</sub> |     | 113  |     | μA                              |
| GPIO high/low input transition, no hysteresis        | IH = 0, transition between reading 0 and reading 1                |     | 1.67 |     | V                               |
| GPIO low-to-high input transition, with hysteresis   | IH = 1, transition voltage for input read as 0 → 1                |     | 1.94 |     | V                               |
| GPIO high-to-low input transition, with hysteresis   | IH = 1, transition voltage for input read as 1 → 0                |     | 1.54 |     | V                               |
| GPIO input hysteresis                                | IH = 1, difference between 0 → 1 and 1 → 0 points                 |     | 0.4  |     | V                               |
| <b>T<sub>A</sub> = 25°C</b>                          |   |     |      |     |                                 |
| V <sub>IH</sub>                                      | Lowest GPIO input voltage reliably interpreted as a «High»        |     |      | 0.8 | V <sub>DD5</sub> <sup>(1)</sup> |
| V <sub>L</sub>                                       | Highest GPIO input voltage reliably interpreted as a «Low»        | 0.2 |      |     | V <sub>DD5</sub> <sup>(1)</sup> |

(1) Each GPIO is referenced to a specific V<sub>DD5</sub> pin. See the technical reference manual listed in [Section 8.2](#) for more details.

**5.21 Thermal Characteristics**

| NAME                  | DESCRIPTION                                  | RSM (°C/W) <sup>(1) (2)</sup> | RHB (°C/W) <sup>(1) (2)</sup> | RGZ (°C/W) <sup>(1) (2)</sup> |
|-----------------------|--|-------------------------------|-------------------------------|-------------------------------|
| R <sub>θJA</sub>      | Junction-to-ambient thermal resistance       | 36.9                          | 32.8                          | 29.6                          |
| R <sub>θJC(top)</sub> | Junction-to-case (top) thermal resistance    | 30.3                          | 24.0                          | 15.7                          |
| R <sub>θJB</sub>      | Junction-to-board thermal resistance         | 7.6                           | 6.8                           | 6.2                           |
| Psi <sub>JT</sub>     | Junction-to-top characterization parameter   | 0.4                           | 0.3                           | 0.3                           |
| Psi <sub>JB</sub>     | Junction-to-board characterization parameter | 7.4                           | 6.8                           | 6.2                           |
| R <sub>θJC(bot)</sub> | Junction-to-case (bottom) thermal resistance | 2.1                           | 1.9                           | 1.9                           |

(1) °C/W = degrees Celsius per watt.

(2) These values are based on a JEDEC-defined 2S2P system (with the exception of the Theta JC [R<sub>θJC</sub>] value, which is based on a JEDEC-defined 1S0P system) and will change based on environment as well as application. For more information, see these EIA/JEDEC standards:

- JESD51-2, *Integrated Circuits Thermal Test Method Environmental Conditions - Natural Convection (Still Air)*.
- JESD51-3, *Low Effective Thermal Conductivity Test Board for Leaded Surface Mount Packages*.
- JESD51-7, *High Effective Thermal Conductivity Test Board for Leaded Surface Mount Packages*.
- JESD51-9, *Test Boards for Area Array Surface Mount Package Thermal Measurements*.

Power dissipation of 2 W and an ambient temperature of 70°C is assumed.

### 5.22 Timing Requirements

|  |  | MIN              | NOM | MAX | UNIT  |                      |
|--|--|------------------|-----|-----|-------|----------------------|
| Rising supply-voltage slew rate  |  | 0                |     | 100 | mV/μs |                      |
| Falling supply-voltage slew rate   |  | 0                |     | 20  | mV/μs |                      |
| Falling supply-voltage slew rate, with low-power flash settings <sup>(1)</sup> |  |                  |     | 3   | mV/μs |                      |
| Positive temperature gradient in standby <sup>(2)</sup>                        | No limitation for negative temperature gradient, or outside standby mode |                  |     | 5   | °C/s  |                      |
| <b>CONTROL INPUT AC CHARACTERISTICS<sup>(3)</sup></b>                          |  |                  |     |     |       |                      |
| RESET_N low duration   |  | 1                |     |     | μs    |                      |
| <b>SYNCHRONOUS SERIAL INTERFACE (SSI)<sup>(4)</sup></b>                        |  |                  |     |     |       |                      |
| S1 (SLAVE) <sup>(5)</sup>  | t <sub>clk_per</sub>   | SSIClk period    |     | 12  | 65024 | system clocks        |
| S2 <sup>(5)</sup>  | t <sub>clk_high</sub>  | SSIClk high time |     | 0.5 |       | t <sub>clk_per</sub> |
| S3 <sup>(5)</sup>  | t <sub>clk_low</sub>   | SSIClk low time  |     | 0.5 |       | t <sub>clk_per</sub> |

- (1) For smaller coin cell batteries, with high worst-case end-of-life equivalent source resistance, a 22-μF V<sub>DDS</sub> input capacitor (see [Figure 7-1](#)) must be used to ensure compliance with this slew rate.
- (2) Applications using RCOSC\_LF as sleep timer must also consider the drift in frequency caused by a change in temperature (see [Section 5.13](#)).
- (3) T<sub>A</sub> = -40°C to 85°C, V<sub>DDS</sub> = 1.7 V to 3.8 V, unless otherwise noted.
- (4) T<sub>c</sub> = 25°C, V<sub>DDS</sub> = 3.0 V, unless otherwise noted. Device operating as SLAVE. For SSI MASTER operation, see [Section 5.23](#).
- (5) Refer to SSI timing diagrams [Figure 5-1](#), [Figure 5-2](#), and [Figure 5-3](#).

### 5.23 Switching Characteristics

Measured on the TI CC2650EM-5XD reference design with T<sub>c</sub> = 25°C, V<sub>DDS</sub> = 3.0 V, unless otherwise noted.

| PARAMETER  | TEST CONDITIONS                | MIN | TYP  | MAX   | UNIT                 |
|--|--------------------------------|-----|------|-------|----------------------|
| <b>WAKEUP AND TIMING</b>   |                                |     |      |       |                      |
| Idle → Active  |                                |     | 14   |       | μs                   |
| Standby → Active   |                                |     | 151  |       | μs                   |
| Shutdown → Active  |                                |     | 1015 |       | μs                   |
| <b>SYNCHRONOUS SERIAL INTERFACE (SSI)<sup>(1)</sup></b>            |                                |     |      |       |                      |
| S1 (TX only) <sup>(2)</sup> t <sub>clk_per</sub> (SSIClk period)   | One-way communication to SLAVE | 4   |      | 65024 | system clocks        |
| S1 (TX and RX) <sup>(2)</sup> t <sub>clk_per</sub> (SSIClk period) | Normal duplex operation        | 8   |      | 65024 | system clocks        |
| S2 <sup>(2)</sup> t <sub>clk_high</sub> (SSIClk high time)         |                                |     | 0.5  |       | t <sub>clk_per</sub> |
| S3 <sup>(2)</sup> t <sub>clk_low</sub> (SSIClk low time)           |                                |     | 0.5  |       | t <sub>clk_per</sub> |

- (1) Device operating as MASTER. For SSI SLAVE operation, see [Section 5.22](#).
- (2) Refer to SSI timing diagrams [Figure 5-1](#), [Figure 5-2](#), and [Figure 5-3](#).

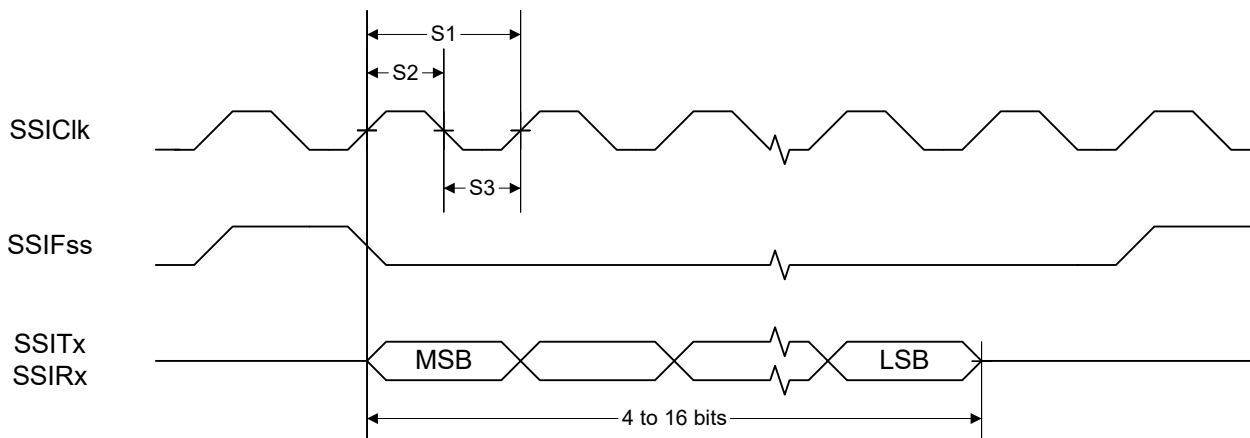

Figure 5-1. SSI Timing for TI Frame Format (FRF = 01), Single Transfer Timing Measurement

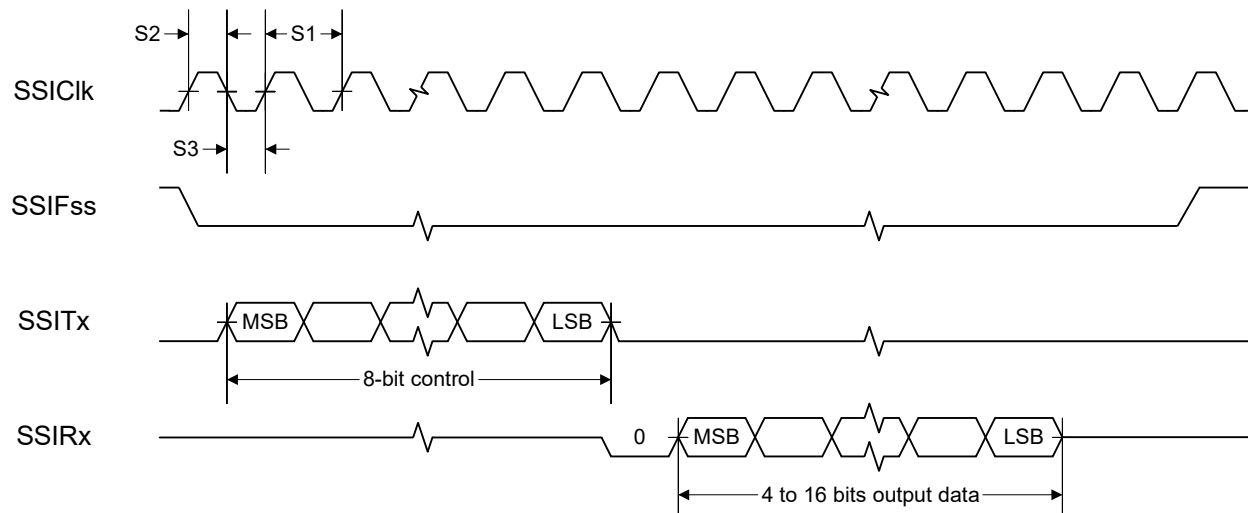

Figure 5-2. SSI Timing for MICROWIRE Frame Format (FRF = 10), Single Transfer

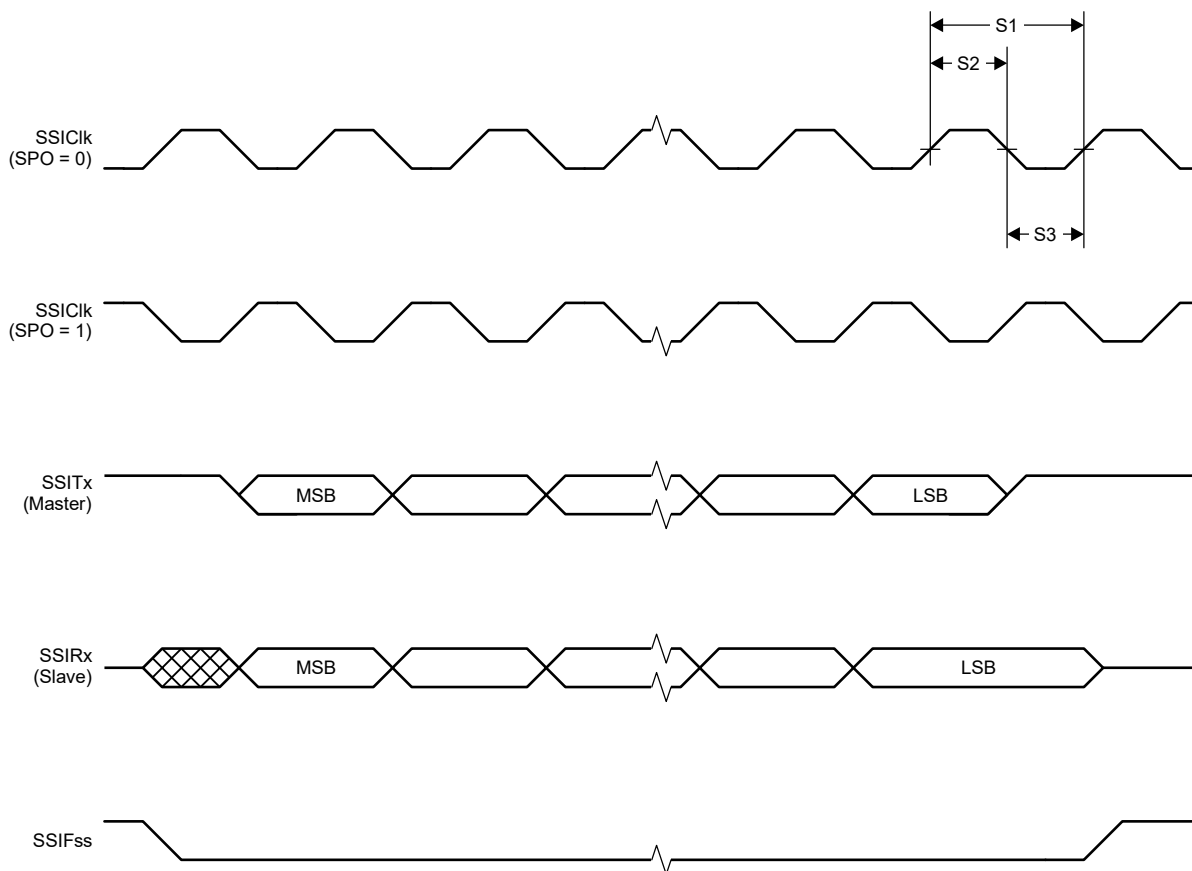

Figure 5-3. SSI Timing for SPI Frame Format (FRF = 00), With SPH = 1

## 5.24 Typical Characteristics

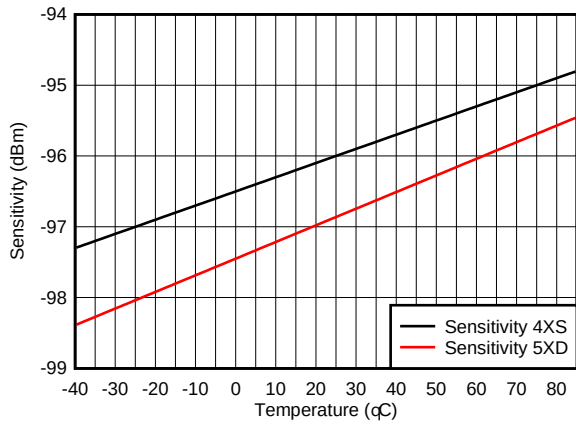

Figure 5-4. BLE Sensitivity vs Temperature

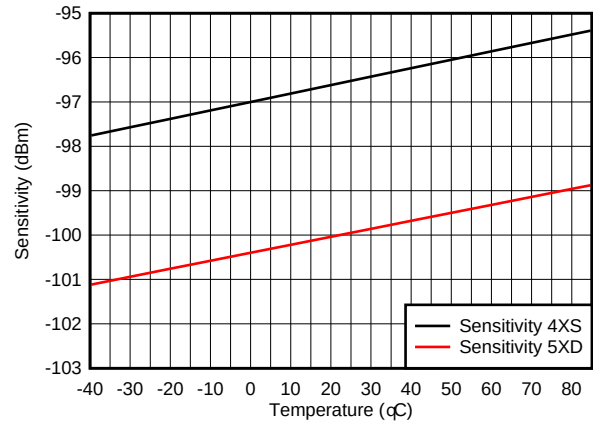

Figure 5-5. IEEE 802.15.4 Sensitivity vs Temperature

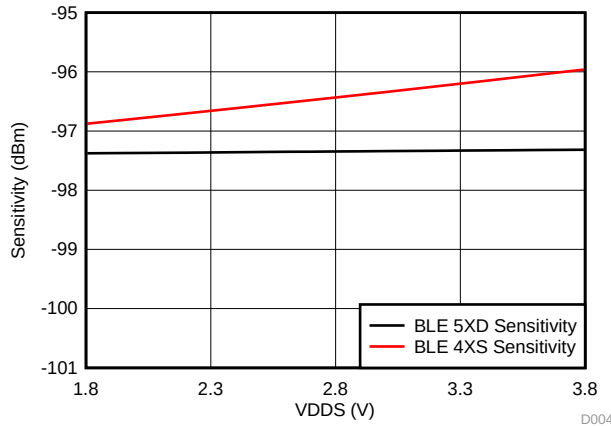

Figure 5-6. BLE Sensitivity vs Supply Voltage (VDD5)

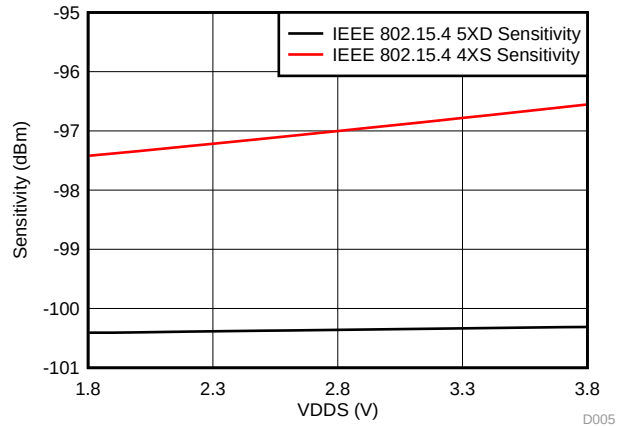

Figure 5-7. IEEE 802.15.4 Sensitivity vs Supply Voltage (VDD5)

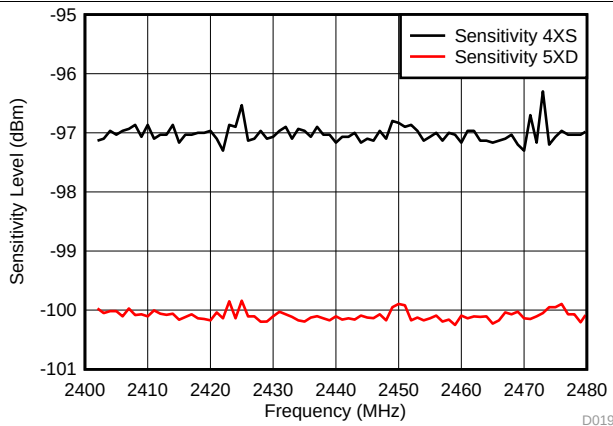

Figure 5-8. IEEE 802.15.4 Sensitivity vs Channel Frequency

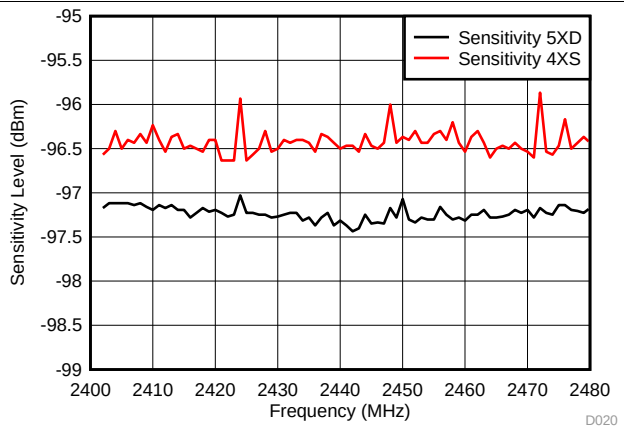

Figure 5-9. BLE Sensitivity vs Channel Frequency



Typical Characteristics (continued)

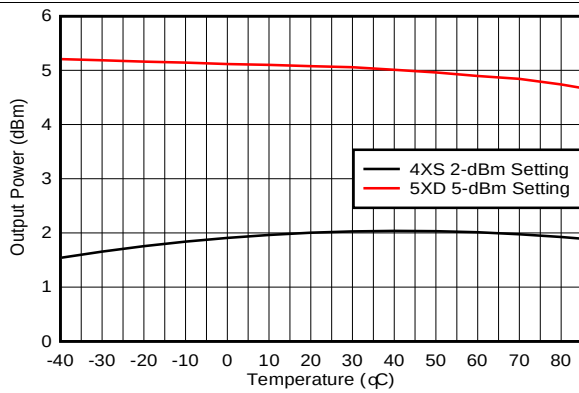

Figure 5-10. TX Output Power vs Temperature

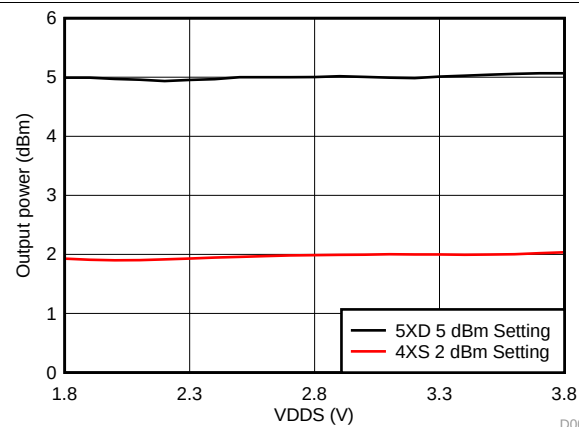

Figure 5-11. TX Output Power vs Supply Voltage (VDD5)

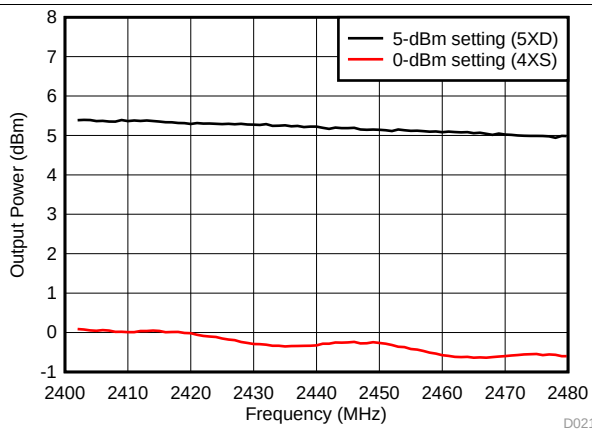

Figure 5-12. TX Output Power vs Channel Frequency

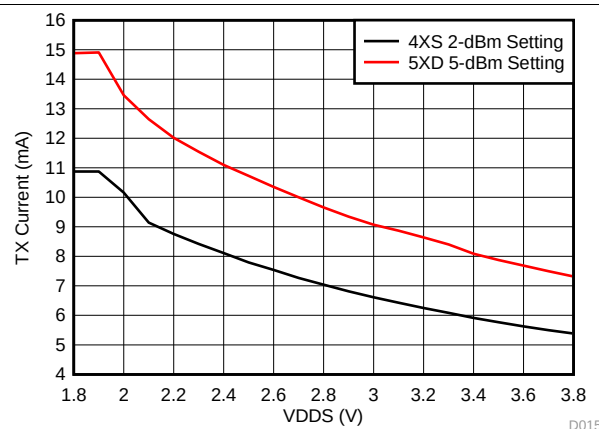

Figure 5-13. TX Current Consumption vs Supply Voltage (VDD5)

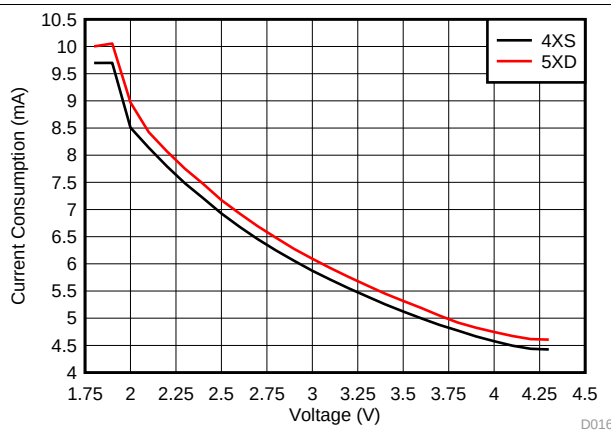

Figure 5-14. RX Mode Current vs Supply Voltage (VDD5)

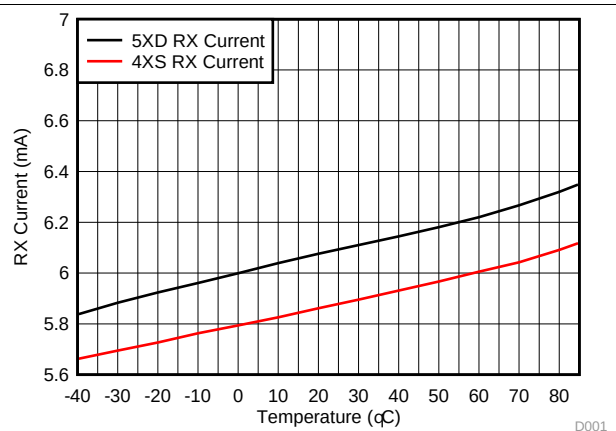

Figure 5-15. RX Mode Current Consumption vs Temperature

Typical Characteristics (continued)

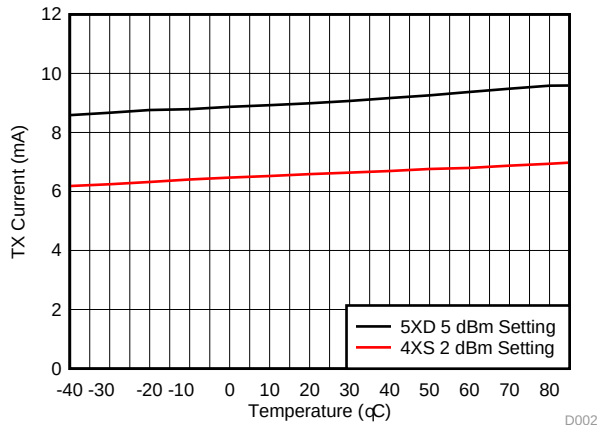

Figure 5-16. TX Mode Current Consumption vs Temperature

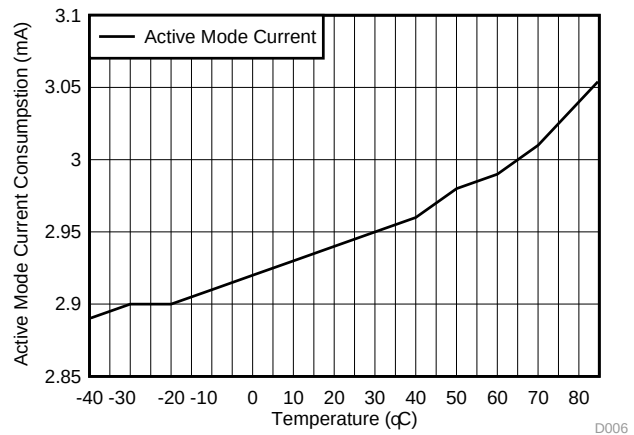

Figure 5-17. Active Mode (MCU Running, No Peripherals) Current Consumption vs Temperature

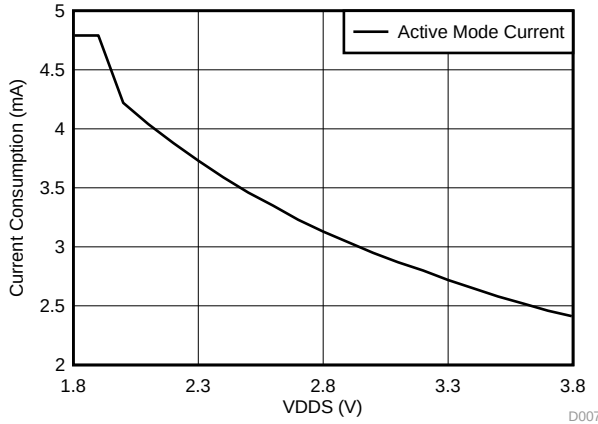

Figure 5-18. Active Mode (MCU Running, No Peripherals) Current Consumption vs Supply Voltage (VDD5)

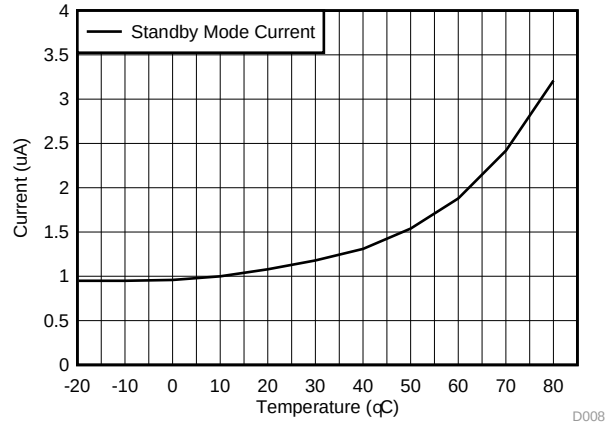

Figure 5-19. Standby Mode Current Consumption With RCOSC RTC vs Temperature

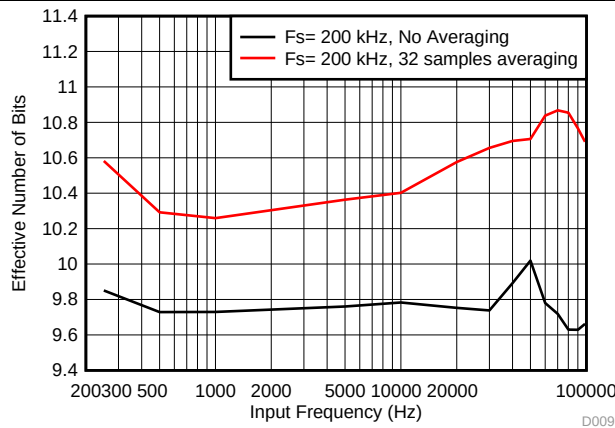

Figure 5-20. SoC ADC Effective Number of Bits vs Input Frequency (Internal Reference, No Scaling)

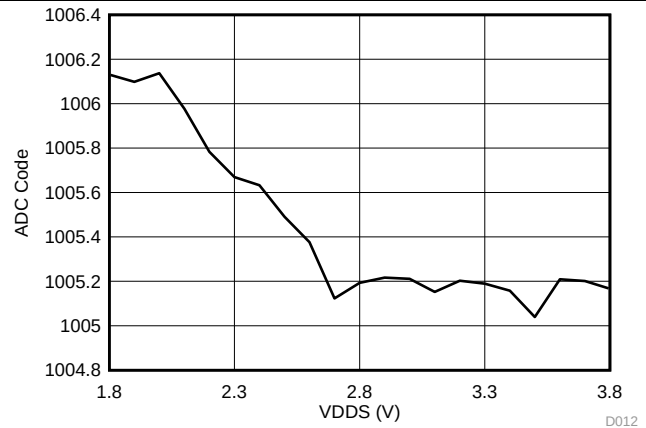
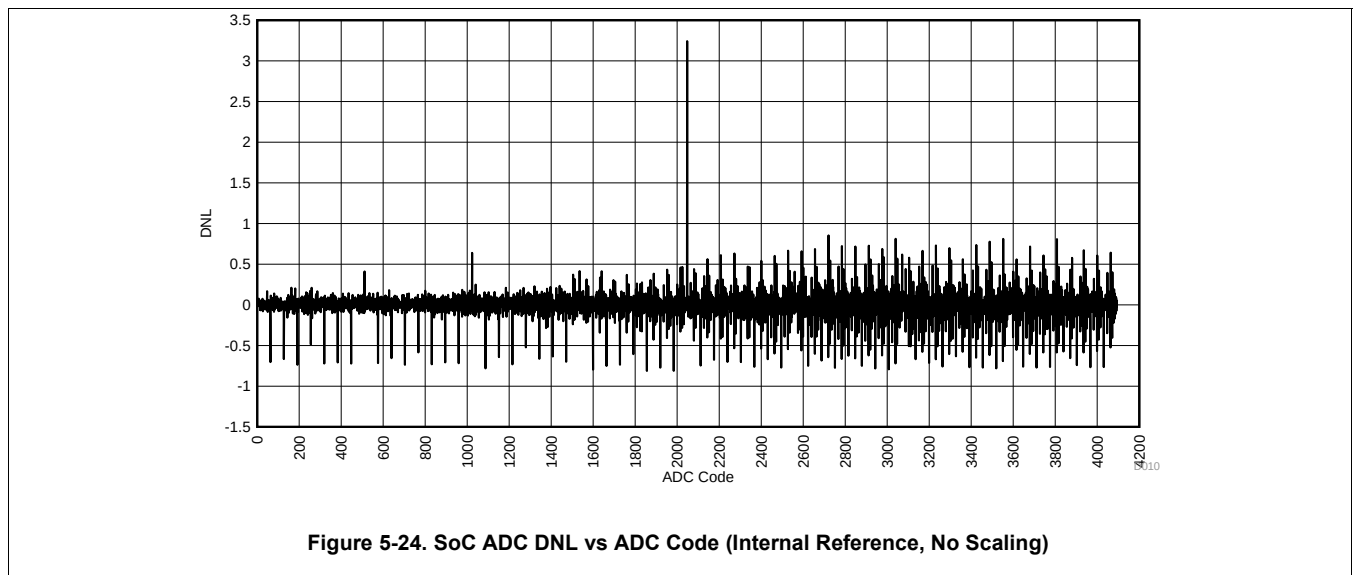
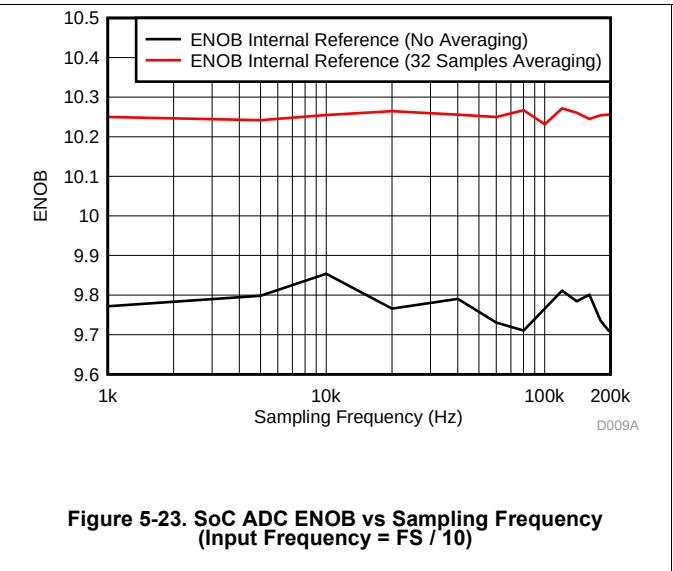
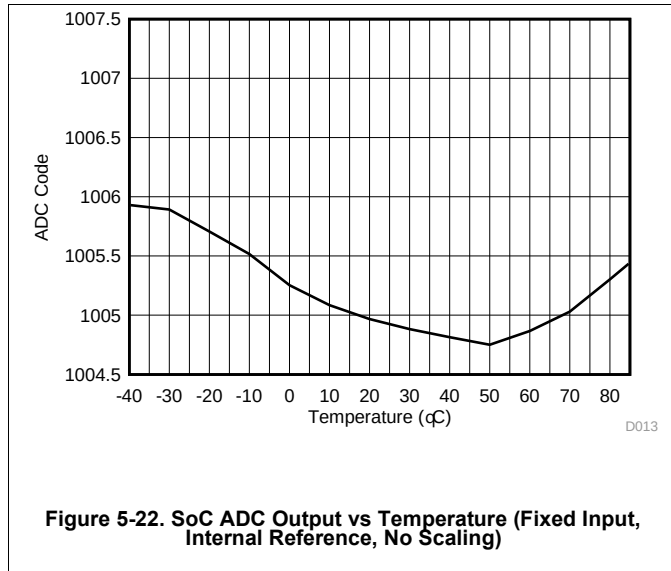

Figure 5-21. SoC ADC Output vs Supply Voltage (Fixed Input, Internal Reference, No Scaling)

Typical Characteristics (continued)



Typical Characteristics (continued)

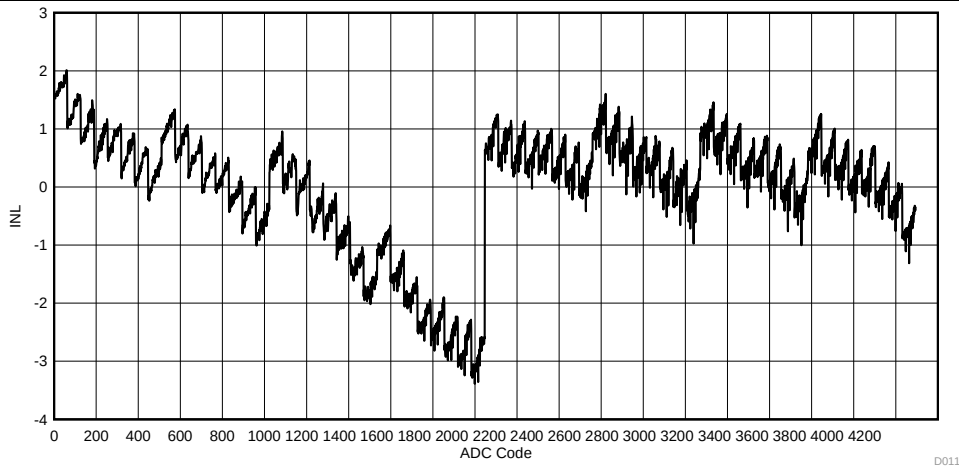

Figure 5-25. SoC ADC INL vs ADC Code (Internal Reference, No Scaling)

## 6 Detailed Description

### 6.1 Overview

The core modules of the CC26xx product family are shown in the [Section 6.2](#).

### 6.2 Functional Block Diagram

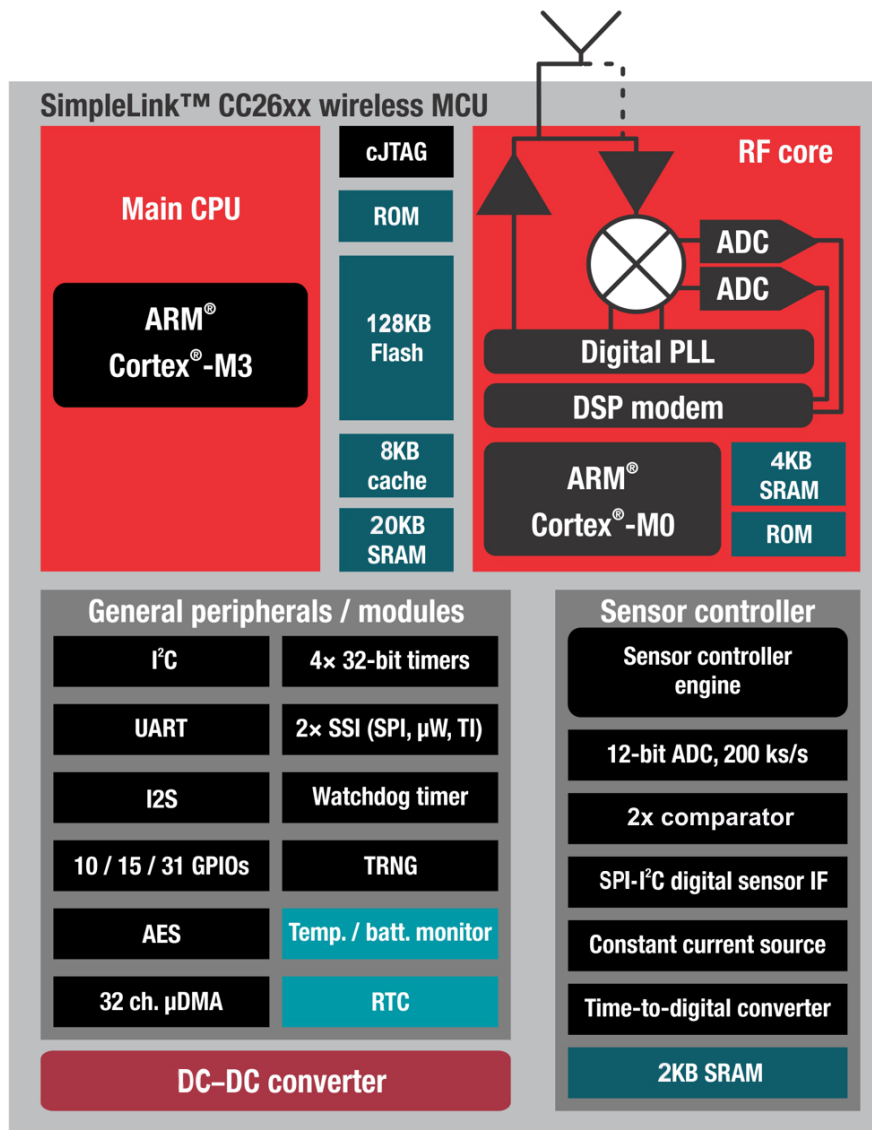

### 6.3 Main CPU

The SimpleLink CC2650 Wireless MCU contains an ARM Cortex-M3 (CM3) 32-bit CPU, which runs the application and the higher layers of the protocol stack.

The CM3 processor provides a high-performance, low-cost platform that meets the system requirements of minimal memory implementation, and low-power consumption, while delivering outstanding computational performance and exceptional system response to interrupts.

CM3 features include the following:

- 32-bit ARM Cortex-M3 architecture optimized for small-footprint embedded applications
- Outstanding processing performance combined with fast interrupt handling
- ARM Thumb<sup>®</sup>-2 mixed 16- and 32-bit instruction set delivers the high performance expected of a 32-bit ARM core in a compact memory size usually associated with 8- and 16-bit devices, typically in the range of a few kilobytes of memory for microcontroller-class applications:
  - Single-cycle multiply instruction and hardware divide
  - Atomic bit manipulation (bit-banding), delivering maximum memory use and streamlined peripheral control
  - Unaligned data access, enabling data to be efficiently packed into memory
- Fast code execution permits slower processor clock or increases sleep mode time
- Harvard architecture characterized by separate buses for instruction and data
- Efficient processor core, system, and memories
- Hardware division and fast digital-signal-processing oriented multiply accumulate
- Saturating arithmetic for signal processing
- Deterministic, high-performance interrupt handling for time-critical applications
- Enhanced system debug with extensive breakpoint and trace capabilities
- Serial wire trace reduces the number of pins required for debugging and tracing
- Migration from the ARM7<sup>™</sup> processor family for better performance and power efficiency
- Optimized for single-cycle flash memory use
- Ultralow-power consumption with integrated sleep modes
- 1.25 DMIPS per MHz

### 6.4 RF Core

The RF Core contains an ARM Cortex-M0 processor that interfaces the analog RF and base-band circuitries, handles data to and from the system side, and assembles the information bits in a given packet structure. The RF core offers a high level, command-based API to the main CPU.

The RF core is capable of autonomously handling the time-critical aspects of the radio protocols (802.15.4 RF4CE and ZigBee, *Bluetooth* Low Energy) thus offloading the main CPU and leaving more resources for the user application.

The RF core has a dedicated 4-KB SRAM block and runs initially from separate ROM memory. The ARM Cortex-M0 processor is not programmable by customers.

## 6.5 Sensor Controller

The Sensor Controller contains circuitry that can be selectively enabled in standby mode. The peripherals in this domain may be controlled by the Sensor Controller Engine which is a proprietary power-optimized CPU. This CPU can read and monitor sensors or perform other tasks autonomously, thereby significantly reducing power consumption and offloading the main CM3 CPU.

The Sensor Controller is set up using a PC-based configuration tool, called Sensor Controller Studio, and potential use cases may be (but are not limited to):

- Analog sensors using integrated ADC
- Digital sensors using GPIOs, bit-banged I<sup>2</sup>C, and SPI
- UART communication for sensor reading or debugging
- Capacitive sensing
- Waveform generation
- Pulse counting
- Keyboard scan
- Quadrature decoder for polling rotation sensors
- Oscillator calibration

---

### NOTE

Texas Instruments provides application examples for some of these use cases, but not for all of them.

---

The peripherals in the Sensor Controller include the following:

- The low-power clocked comparator can be used to wake the device from any state in which the comparator is active. A configurable internal reference can be used in conjunction with the comparator. The output of the comparator can also be used to trigger an interrupt or the ADC.
- Capacitive sensing functionality is implemented through the use of a constant current source, a time-to-digital converter, and a comparator. The continuous time comparator in this block can also be used as a higher-accuracy alternative to the low-power clocked comparator. The Sensor Controller will take care of baseline tracking, hysteresis, filtering and other related functions.
- The ADC is a 12-bit, 200-ksamples/s ADC with eight inputs and a built-in voltage reference. The ADC can be triggered by many different sources, including timers, I/O pins, software, the analog comparator, and the RTC.
- The Sensor Controller also includes a SPI-I<sup>2</sup>C digital interface.
- The analog modules can be connected to up to eight different GPIOs.

The peripherals in the Sensor Controller can also be controlled from the main application processor.

**Table 6-1. GPIOs Connected to the Sensor Controller <sup>(1)</sup>**

| ANALOG CAPABLE | 7 × 7 RGZ<br>DIO NUMBER | 5 × 5 RHB<br>DIO NUMBER | 4 × 4 RSM<br>DIO NUMBER |
|----------------|-------------------------|-------------------------|-------------------------|
| Y              | 30                      | 14                      |                         |
| Y              | 29                      | 13                      |                         |
| Y              | 28                      | 12                      |                         |
| Y              | 27                      | 11                      | 9                       |
| Y              | 26                      | 9                       | 8                       |
| Y              | 25                      | 10                      | 7                       |
| Y              | 24                      | 8                       | 6                       |
| Y              | 23                      | 7                       | 5                       |
| N              | 7                       | 4                       | 2                       |
| N              | 6                       | 3                       | 1                       |
| N              | 5                       | 2                       | 0                       |
| N              | 4                       | 1                       |                         |
| N              | 3                       | 0                       |                         |
| N              | 2                       |                         |                         |
| N              | 1                       |                         |                         |
| N              | 0                       |                         |                         |

(1) Depending on the package size, up to 16 pins can be connected to the Sensor Controller. Up to 8 of these pins can be connected to analog modules.

## 6.6 Memory

The flash memory provides nonvolatile storage for code and data. The flash memory is in-system programmable.

The SRAM (static RAM) can be used for both storage of data and execution of code and is split into two 4-KB blocks and two 6-KB blocks. Retention of the RAM contents in standby mode can be enabled or disabled individually for each block to minimize power consumption. In addition, if flash cache is disabled, the 8-KB cache can be used as a general-purpose RAM.

The ROM provides preprogrammed embedded TI RTOS kernel, Driverlib and lower layer protocol stack software (802.15.4 MAC and *Bluetooth* Low Energy Controller). It also contains a bootloader that can be used to reprogram the device using SPI or UART.

## 6.7 Debug

The on-chip debug support is done through a dedicated cJTAG (IEEE 1149.7) or JTAG (IEEE 1149.1) interface.



## 6.8 Power Management

To minimize power consumption, the CC2650 device supports a number of power modes and power management features (see [Table 6-2](#)).

**Table 6-2. Power Modes**

| MODE                                      | SOFTWARE CONFIGURABLE POWER MODES |                     |                            |           | RESET PIN HELD |
|---|-----------------------------------|---------------------|----------------------------|-----------|----------------|
|   | ACTIVE                            | IDLE                | STANDBY                    | SHUTDOWN  |                |
| CPU                                       | Active                            | Off                 | Off                        | Off       | Off            |
| Flash                                     | On                                | Available           | Off                        | Off       | Off            |
| SRAM                                      | On                                | On                  | On                         | Off       | Off            |
| Radio                                     | Available                         | Available           | Off                        | Off       | Off            |
| Supply System                             | On                                | On                  | Duty Cycled                | Off       | Off            |
| Current                                   | 1.45 mA + 31 µA/MHz               | 550 µA              | 1 µA                       | 0.15 µA   | 0.1 µA         |
| Wake-up Time to CPU Active <sup>(1)</sup> | –                                 | 14 µs               | 151 µs                     | 1015 µs   | 1015 µs        |
| Register Retention                        | Full                              | Full                | Partial                    | No        | No             |
| SRAM Retention                            | Full                              | Full                | Full                       | No        | No             |
| High-Speed Clock                          | XOSC_HF or RCOSC_HF               | XOSC_HF or RCOSC_HF | Off                        | Off       | Off            |
| Low-Speed Clock                           | XOSC_LF or RCOSC_LF               | XOSC_LF or RCOSC_LF | XOSC_LF or RCOSC_LF        | Off       | Off            |
| Peripherals                               | Available                         | Available           | Off                        | Off       | Off            |
| Sensor Controller                         | Available                         | Available           | Available                  | Off       | Off            |
| Wake up on RTC                            | Available                         | Available           | Available                  | Off       | Off            |
| Wake up on Pin Edge                       | Available                         | Available           | Available                  | Available | Off            |
| Wake up on Reset Pin                      | Available                         | Available           | Available                  | Available | Available      |
| Brown Out Detector (BOD)                  | Active                            | Active              | Duty Cycled <sup>(2)</sup> | Off       | N/A            |
| Power On Reset (POR)                      | Active                            | Active              | Active                     | Active    | N/A            |

(1) Not including RTOS overhead

(2) The Brown Out Detector is disabled between recharge periods in STANDBY. Lowering the supply voltage below the BOD threshold between two recharge periods while in STANDBY may cause the BOD to lock the device upon wake-up until a Reset/POR releases it. To avoid this, it is recommended that STANDBY mode is avoided if there is a risk that the supply voltage (VDD5) may drop below the specified operating voltage range. For the same reason, it is also good practice to ensure that a power cycling operation, such as a battery replacement, triggers a Power-on-reset by ensuring that the VDD5 decoupling network is fully depleted before applying supply voltage again (for example, inserting new batteries).

In active mode, the application CM3 CPU is actively executing code. Active mode provides normal operation of the processor and all of the peripherals that are currently enabled. The system clock can be any available clock source (see [Table 6-2](#)).

In idle mode, all active peripherals can be clocked, but the Application CPU core and memory are not clocked and no code is executed. Any interrupt event will bring the processor back into active mode.

In standby mode, only the always-on domain (AON) is active. An external wake event, RTC event, or sensor-controller event is required to bring the device back to active mode. MCU peripherals with retention do not need to be reconfigured when waking up again, and the CPU continues execution from where it went into standby mode. All GPIOs are latched in standby mode.

In shutdown mode, the device is turned off entirely, including the AON domain and the Sensor Controller. The I/Os are latched with the value they had before entering shutdown mode. A change of state on any I/O pin defined as a *wake from Shutdown pin* wakes up the device and functions as a reset trigger. The CPU can differentiate between a reset in this way, a reset-by-reset pin, or a power-on-reset by reading the reset status register. The only state retained in this mode is the latched I/O state and the Flash memory contents.

The Sensor Controller is an autonomous processor that can control the peripherals in the Sensor Controller independently of the main CPU, which means that the main CPU does not have to wake up, for example, to execute an ADC sample or poll a digital sensor over SPI. The main CPU saves both current and wake-up time that would otherwise be wasted. The Sensor Controller Studio enables the user to configure the sensor controller and choose which peripherals are controlled and which conditions wake up the main CPU.

## 6.9 Clock Systems

The CC2650 supports two external and two internal clock sources.

A 24-MHz crystal is required as the frequency reference for the radio. This signal is doubled internally to create a 48-MHz clock.

The 32-kHz crystal is optional. *Bluetooth* low energy requires a slow-speed clock with better than  $\pm 500$  ppm accuracy if the device is to enter any sleep mode while maintaining a connection. The internal 32-kHz RC oscillator can in some use cases be compensated to meet the requirements. The low-speed crystal oscillator is designed for use with a 32-kHz watch-type crystal.

The internal high-speed oscillator (48-MHz) can be used as a clock source for the CPU subsystem.

The internal low-speed oscillator (32.768-kHz) can be used as a reference if the low-power crystal oscillator is not used.

The 32-kHz clock source can be used as external clocking reference through GPIO.

## 6.10 General Peripherals and Modules

The I/O controller controls the digital I/O pins and contains multiplexer circuitry to allow a set of peripherals to be assigned to I/O pins in a flexible manner. All digital I/Os are interrupt and wake-up capable, have a programmable pullup and pulldown function and can generate an interrupt on a negative or positive edge (configurable). When configured as an output, pins can function as either push-pull or open-drain. Five GPIOs have high drive capabilities (marked in **bold** in [Section 4](#)).

The SSIs are synchronous serial interfaces that are compatible with SPI, MICROWIRE, and Texas Instruments synchronous serial interfaces. The SSIs support both SPI master and slave up to 4 MHz.

The UART implements a universal asynchronous receiver/transmitter function. It supports flexible baud-rate generation up to a maximum of 3 Mbps and is compatible with the *Bluetooth* HCI specifications.

Timer 0 is a general-purpose timer module (GPTM), which provides two 16-bit timers. The GPTM can be configured to operate as a single 32-bit timer, dual 16-bit timers or as a PWM module.

Timer 1, Timer 2, and Timer 3 are also GPTMs. Each of these timers is functionally equivalent to Timer 0.

In addition to these four timers, the RF core has its own timer to handle timing for RF protocols; the RF timer can be synchronized to the RTC.

The I<sup>2</sup>C interface is used to communicate with devices compatible with the I<sup>2</sup>C standard. The I<sup>2</sup>C interface is capable of 100-kHz and 400-kHz operation, and can serve as both I<sup>2</sup>C master and I<sup>2</sup>C slave.

The TRNG module provides a true, nondeterministic noise source for the purpose of generating keys, initialization vectors (IVs), and other random number requirements. The TRNG is built on 24 ring oscillators that create unpredictable output to feed a complex nonlinear combinatorial circuit.

The watchdog timer is used to regain control if the system fails due to a software error after an external device fails to respond as expected. The watchdog timer can generate an interrupt or a reset when a predefined time-out value is reached.

The device includes a direct memory access ( $\mu$ DMA) controller. The  $\mu$ DMA controller provides a way to offload data transfer tasks from the CM3 CPU, allowing for more efficient use of the processor and the available bus bandwidth. The  $\mu$ DMA controller can perform transfer between memory and peripherals. The  $\mu$ DMA controller has dedicated channels for each supported on-chip module and can be programmed to automatically perform transfers between peripherals and memory as the peripheral is ready to transfer more data. Some features of the  $\mu$ DMA controller include the following (this is not an exhaustive list):

- Highly flexible and configurable channel operation of up to 32 channels
- Transfer modes:
  - Memory-to-memory
  - Memory-to-peripheral
  - Peripheral-to-memory
  - Peripheral-to-peripheral
- Data sizes of 8, 16, and 32 bits

The AON domain contains circuitry that is always enabled, except for in Shutdown (where the digital supply is off). This circuitry includes the following:

- The RTC can be used to wake the device from any state where it is active. The RTC contains three compare and one capture registers. With software support, the RTC can be used for clock and calendar operation. The RTC is clocked from the 32-kHz RC oscillator or crystal. The RTC can also be compensated to tick at the correct frequency even when the internal 32-kHz RC oscillator is used instead of a crystal.
- The battery monitor and temperature sensor are accessible by software and give a battery status indication as well as a coarse temperature measure.

## 6.11 System Architecture

Depending on the product configuration, CC26xx can function either as a Wireless Network Processor (WNP—an IC running the wireless protocol stack, with the application running on a separate MCU), or as a System-on-Chip (SoC), with the application and protocol stack running on the ARM CM3 core inside the device.

In the first case, the external host MCU communicates with the device using SPI or UART. In the second case, the application must be written according to the application framework supplied with the wireless protocol stack.

## 7 Application, Implementation, and Layout

### NOTE

Information in the following applications sections is not part of the TI component specification, and TI does not warrant its accuracy or completeness. TI's customers are responsible for determining suitability of components for their purposes. Customers should validate and test their design implementation to confirm system functionality.

### 7.1 Application Information

Very few external components are required for the operation of the CC2650 device. This section provides some general information about the various configuration options when using the CC2650 in an application, and then shows two examples of application circuits with schematics and layout. Complete reference designs are available in the product folder on [www.ti.com](http://www.ti.com). Figure 7-1 shows the various RF front-end configuration options. The RF front end can be used in differential- or single-ended configurations with the options of having internal or external biasing. These options allow for various trade-offs between cost, board space, and RF performance. Differential operation with external bias gives the best performance while single-ended operation with internal bias gives the least amount of external components and the lowest power consumption. Reference designs exist for each of these options.

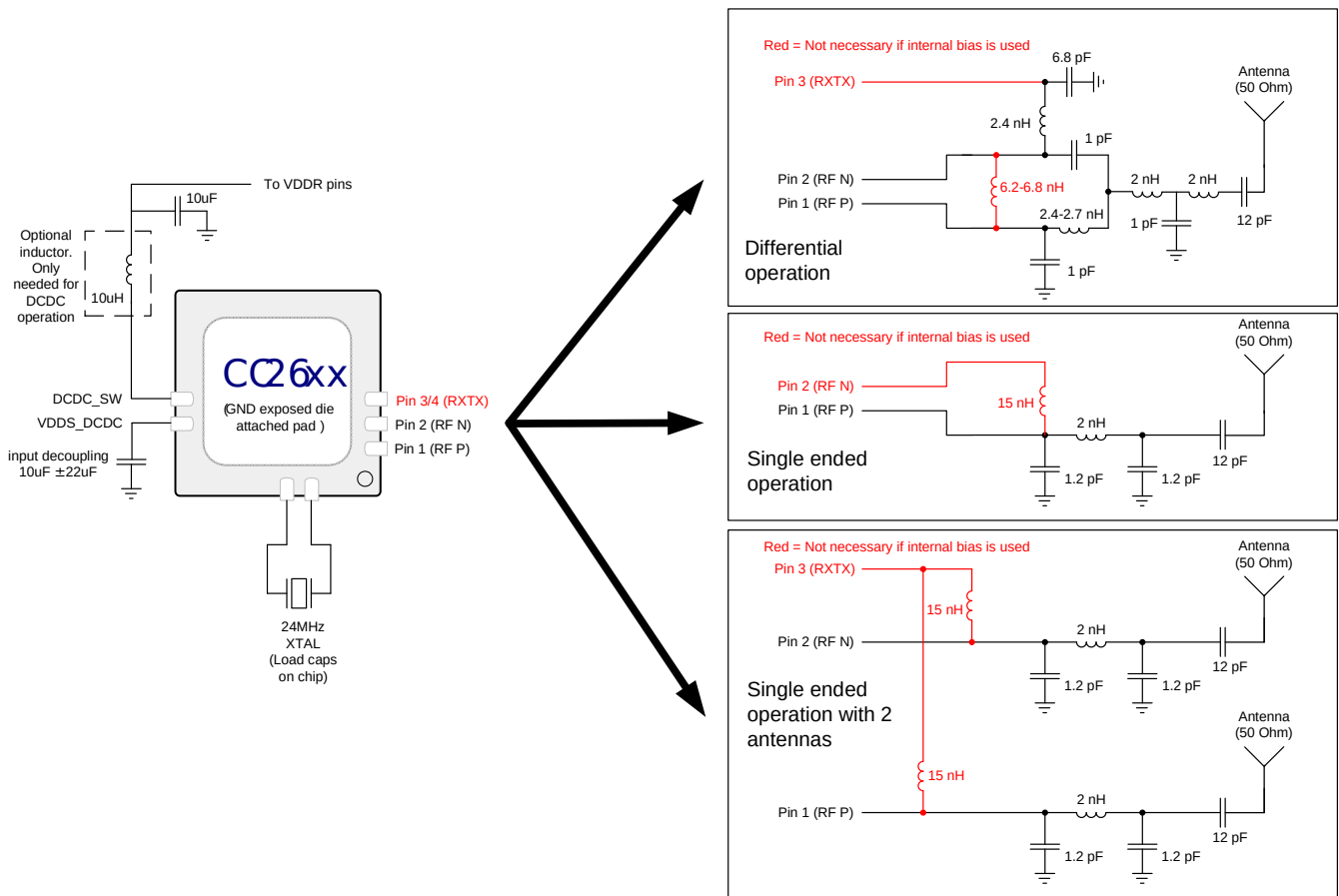

Figure 7-1. CC2650 Application Circuit

Figure 7-2 shows the various supply voltage configuration options. Not all power supply decoupling capacitors or digital I/Os are shown. Exact pin positions will vary between the different package options. For a detailed overview of power supply decoupling and wiring, see the TI reference designs and the CC26xx technical reference manual (Section 8.2).

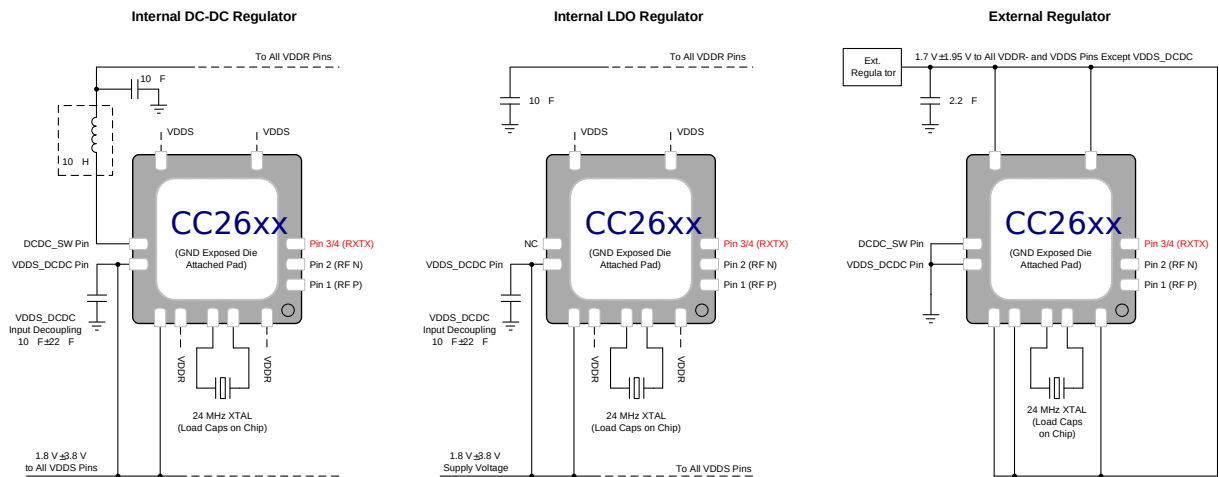

Figure 7-2. Supply Voltage Configurations

### 7.2 5 × 5 External Differential (5XD) Application Circuit

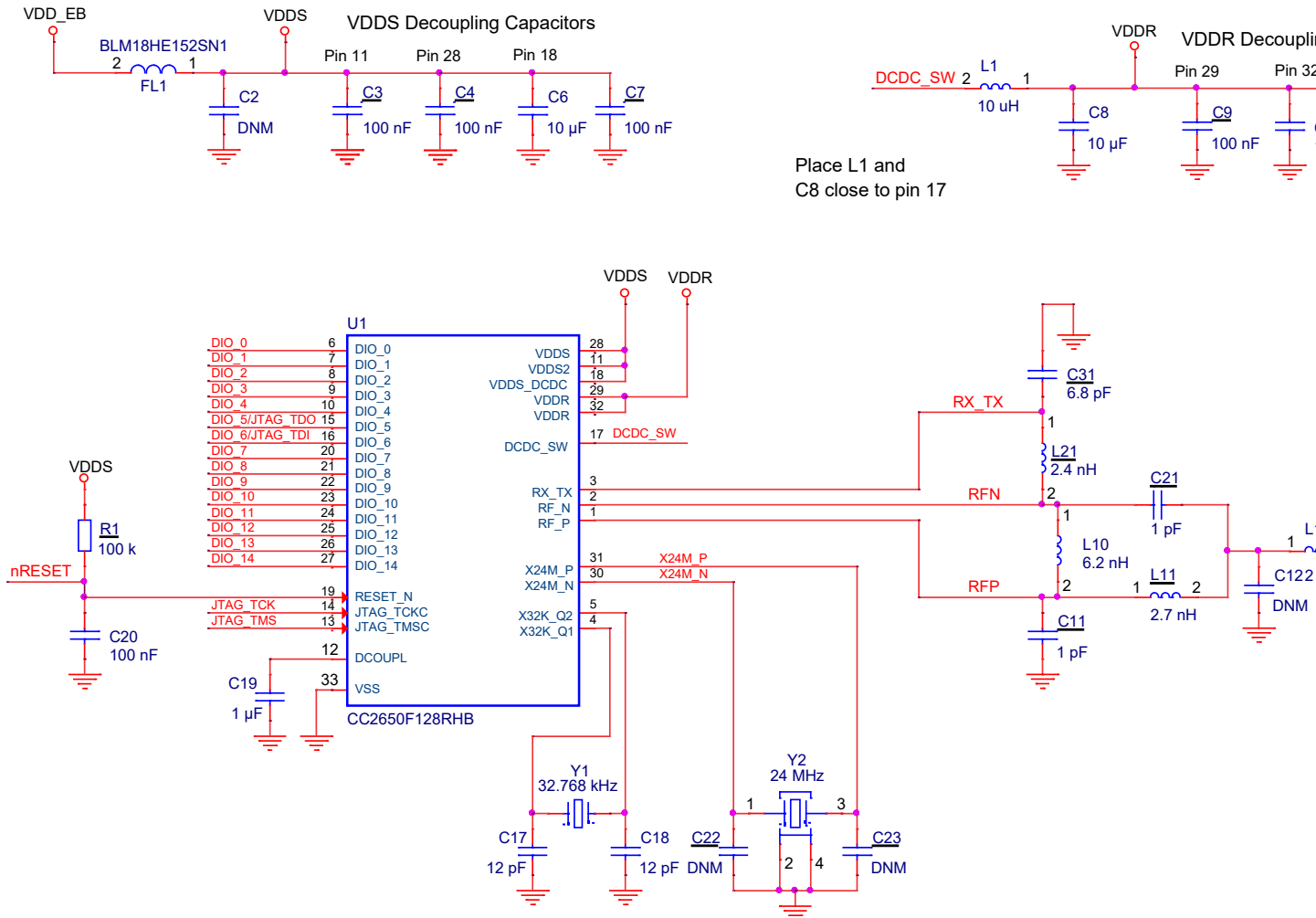

Figure 7-3. 5 × 5 External Differential (5XD) Application Circuit

### 7.2.1 Layout

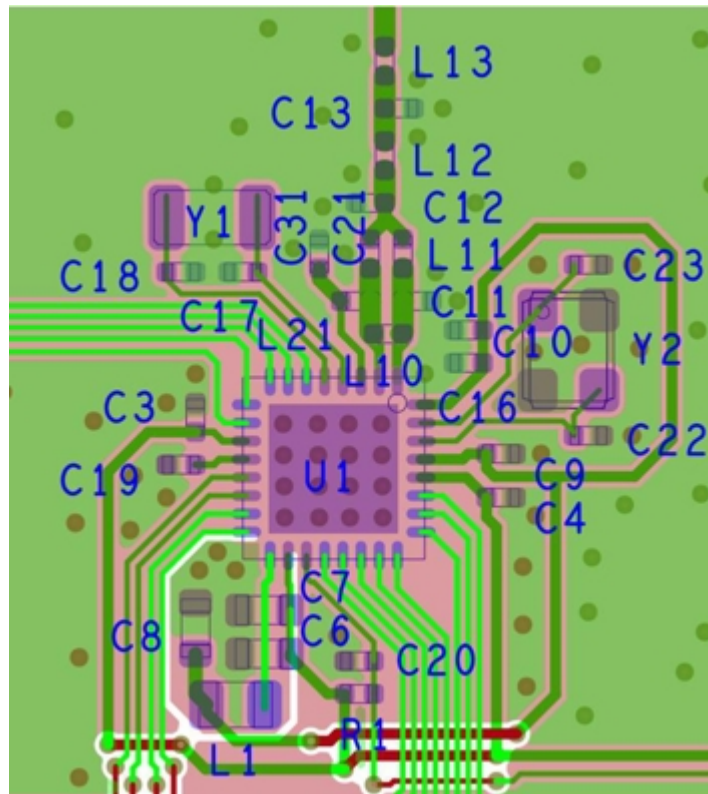

Figure 7-4. 5 × 5 External Differential (5XD) Layout

### 7.3 4 × 4 External Single-ended (4XS) Application Circuit

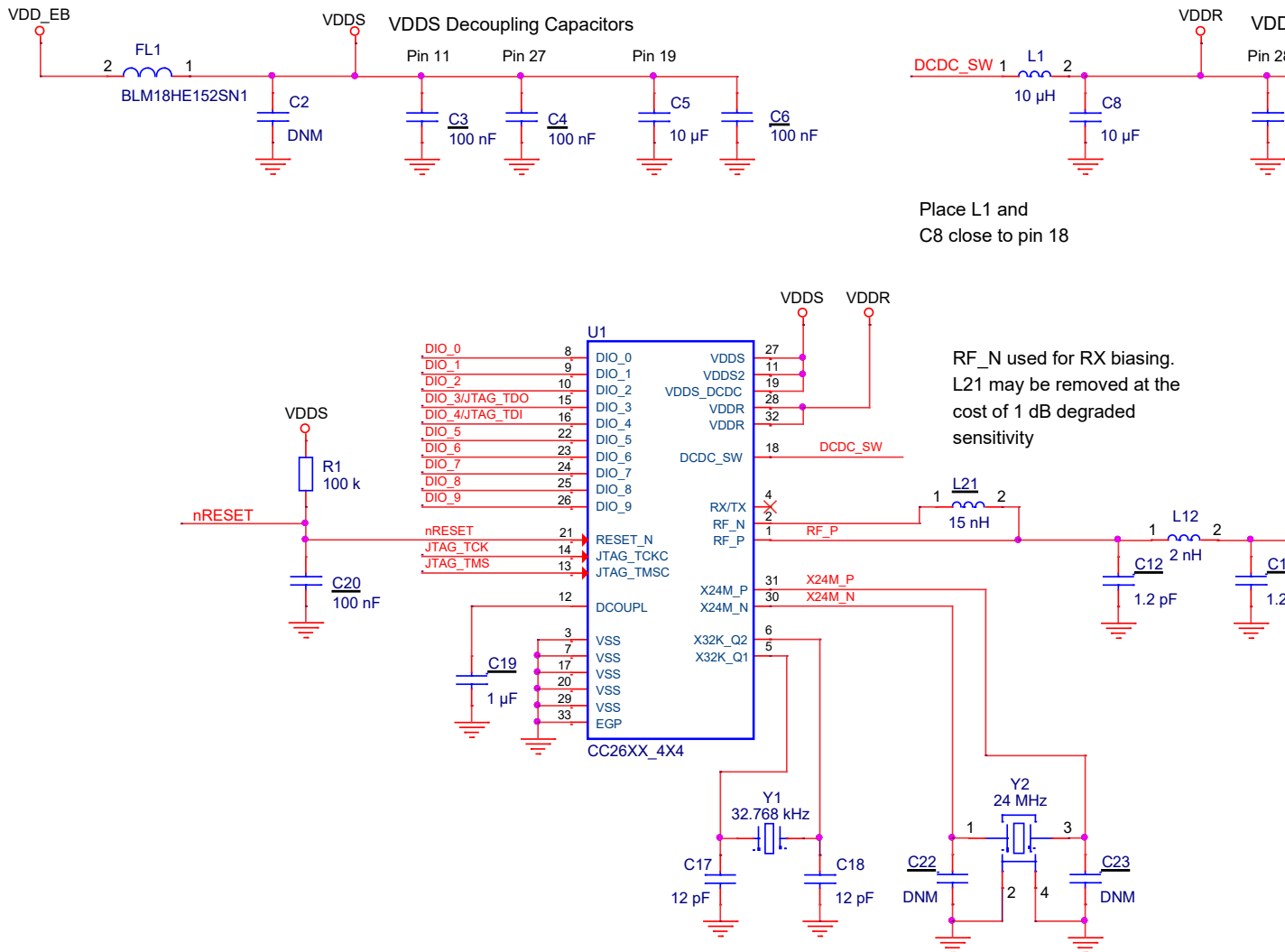

Figure 7-5. 4 × 4 External Single-ended (4XS) Application Circuit



### 7.3.1 Layout

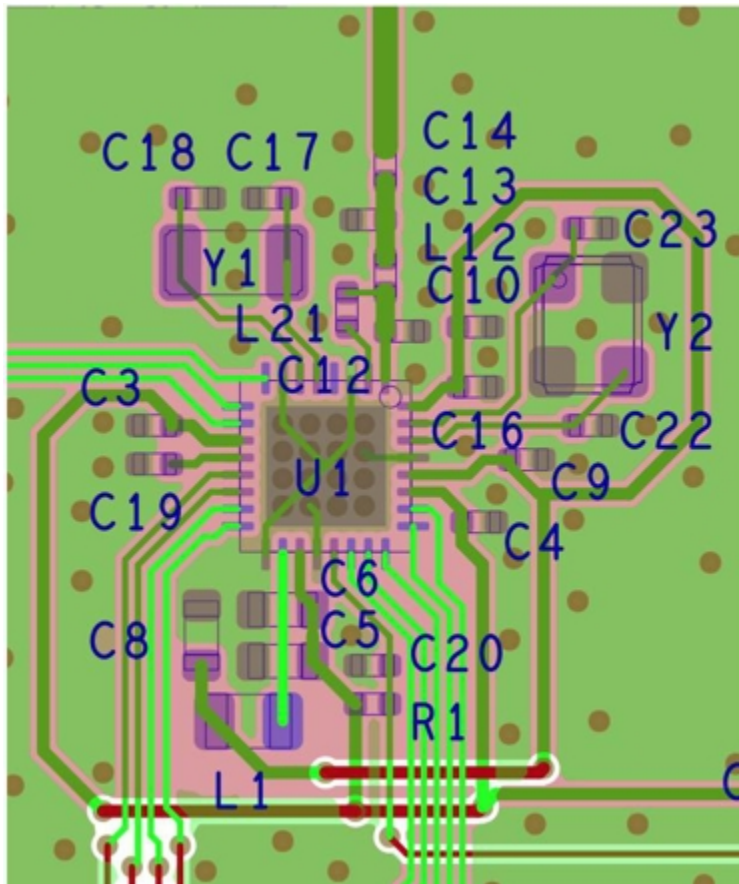

Figure 7-6. 4 × 4 External Single-ended (4XS) Layout

## 8 Device and Documentation Support

### 8.1 Device Support

#### 8.1.1 Development Support

TI offers an extensive line of development tools, including tools to evaluate the performance of the processors, generate code, develop algorithm implementations, and fully integrate and debug software and hardware modules.

The following products support development of the CC2650 device applications:

##### Software Tools:

##### SmartRF Studio 7:

SmartRF Studio is a PC application that helps designers of radio systems to easily evaluate the RF-IC at an early stage in the design process.

- Test functions for sending and receiving radio packets, continuous wave transmit and receive
- Evaluate RF performance on custom boards by wiring it to a supported evaluation board or debugger
- Can also be used without any hardware, but then only to generate, edit and export radio configuration settings
- Can be used in combination with several development kits for Texas Instruments' CCxxxx RF-ICs

##### Sensor Controller Studio:

Sensor Controller Studio provides a development environment for the CC26xx Sensor Controller. The Sensor Controller is a proprietary, power-optimized CPU in the CC26xx, which can perform simple background tasks autonomously and independent of the System CPU state.

- Allows for Sensor Controller task algorithms to be implemented using a C-like programming language
- Outputs a Sensor Controller Interface driver, which incorporates the generated Sensor Controller machine code and associated definitions
- Allows for rapid development by using the integrated Sensor Controller task testing and debugging functionality. This allows for live visualization of sensor data and algorithm verification.

##### IDEs and Compilers:

##### Code Composer Studio:

- Integrated development environment with project management tools and editor
- Code Composer Studio (CCS) 6.1 and later has built-in support for the CC26xx device family
- Best support for XDS debuggers; XDS100v3, XDS110 and XDS200
- High integration with TI-RTOS with support for TI-RTOS Object View

##### IAR Embedded Workbench for ARM

- Integrated development environment with project management tools and editor
- IAR EWARM 7.30.3 and later has built-in support for the CC26xx device family
- Broad debugger support, supporting XDS100v3, XDS200, IAR I-Jet and Segger J-Link
- Integrated development environment with project management tools and editor
- RTOS plugin available for [TI-RTOS](#)

For a complete listing of development-support tools for the CC2650 platform, visit the Texas Instruments website at [www.ti.com](http://www.ti.com). For information on pricing and availability, contact the nearest TI field sales office or authorized distributor.

### 8.1.2 Device Nomenclature

To designate the stages in the product development cycle, TI assigns prefixes to all part numbers and date-code. Each device has one of three prefixes/identifications: X, P, or null (no prefix) (for example, CC2650 is in production; therefore, no prefix/identification is assigned).

Device development evolutionary flow:

- X** Experimental device that is not necessarily representative of the final device's electrical specifications and may not use production assembly flow.
- P** Prototype device that is not necessarily the final silicon die and may not necessarily meet final electrical specifications.
- null** Production version of the silicon die that is fully qualified.

Production devices have been characterized fully, and the quality and reliability of the device have been demonstrated fully. TI's standard warranty applies.

Predictions show that prototype devices (X or P) have a greater failure rate than the standard production devices. Texas Instruments recommends that these devices not be used in any production system because their expected end-use failure rate still is undefined. Only qualified production devices are to be used.

TI device nomenclature also includes a suffix with the device family name. This suffix indicates the package type (for example, *RSM*).

For orderable part numbers of the CC2650 device in the *RSM*, *RHB* or *RGZ* package types, see the Package Option Addendum of this document, the TI website ([www.ti.com](http://www.ti.com)), or contact your TI sales representative.

## 8.2 Documentation Support

The following documents describe the CC2650. Copies of these documents are available on the Internet at [www.ti.com](http://www.ti.com).

**SWCU117** *CC26xx SimpleLink™ Wireless MCU Technical Reference Manual*

**SWRZ058** *CC26xx SimpleLink™ Wireless MCU Errata*

## 8.3 Community Resources

The following links connect to TI community resources. Linked contents are provided "AS IS" by the respective contributors. They do not constitute TI specifications and do not necessarily reflect TI's views; see TI's [Terms of Use](#).

**TI E2E™ Online Community** *TI's Engineer-to-Engineer (E2E) Community*. Created to foster collaboration among engineers. At [e2e.ti.com](http://e2e.ti.com), you can ask questions, share knowledge, explore ideas and help solve problems with fellow engineers.

**TI Embedded Processors Wiki** *Texas Instruments Embedded Processors Wiki*. Established to help developers get started with Embedded Processors from Texas Instruments and to foster innovation and growth of general knowledge about the hardware and software surrounding these devices.

## 8.4 Texas Instruments Low-Power RF Website

Texas Instruments' Low-Power RF website has all the latest products, application and design notes, FAQ section, news and events updates. Go to [www.ti.com/lprf](http://www.ti.com/lprf).

## 8.5 Low-Power RF Online Community

- Forums, videos, and blogs
- RF design help
- E2E interaction

Join at: [www.ti.com/lprf-forum](http://www.ti.com/lprf-forum).

## 8.6 Texas Instruments Low-Power RF Developer Network

Texas Instruments has launched an extensive network of low-power RF development partners to help customers speed up their application development. The network consists of recommended companies, RF consultants, and independent design houses that provide a series of hardware module products and design services, including:

- RF circuit, low-power RF, and ZigBee design services
- Low-power RF and ZigBee module solutions and development tools
- RF certification services and RF circuit manufacturing

For help with modules, engineering services or development tools:

Search the [Low-Power RF Developer Network](#) to find a suitable partner. [www.ti.com/lprfnetwork](http://www.ti.com/lprfnetwork)

## 8.7 Low-Power RF eNewsletter

The Low-Power RF eNewsletter is up-to-date on new products, news releases, developers' news, and other news and events associated with low-power RF products from TI. The Low-Power RF eNewsletter articles include links to get more online information.

Sign up at: [www.ti.com/lprfnewsletter](http://www.ti.com/lprfnewsletter)

## 8.8 Additional Information

Texas Instruments offers a wide selection of cost-effective, low-power RF solutions for proprietary and standard-based wireless applications for use in industrial and consumer applications. The selection includes RF transceivers, RF transmitters, RF front ends, and Systems-on-Chips as well as various software solutions for the sub-1-GHz and 2.4-GHz frequency bands.

In addition, Texas Instruments provides a large selection of support collateral such as development tools, technical documentation, reference designs, application expertise, customer support, third-party and university programs.

The Low-Power RF E2E Online Community provides technical support forums, videos and blogs, and the chance to interact with engineers from all over the world.

With a broad selection of product solutions, end-application possibilities, and a range of technical support, Texas Instruments offers the broadest low-power RF portfolio.

## 8.9 Trademarks

SimpleLink, SmartRF, Code Composer Studio, E2E are trademarks of Texas Instruments.

ARM7 is a trademark of ARM Limited (or its subsidiaries).

ARM, Cortex, ARM Thumb are registered trademarks of ARM Limited (or its subsidiaries).

*Bluetooth* is a registered trademark of Bluetooth SIG, Inc.

CoreMark is a registered trademark of Embedded Microprocessor Benchmark Consortium.

IAR Embedded Workbench is a registered trademark of IAR Systems AB.

IEEE Std 1241 is a trademark of Institute of Electrical and Electronics Engineers, Incorporated.

ZigBee is a registered trademark of ZigBee Alliance, Inc.

## 8.10 Electrostatic Discharge Caution



This integrated circuit can be damaged by ESD. Texas Instruments recommends that all integrated circuits be handled with appropriate precautions. Failure to observe proper handling and installation procedures can cause damage.

ESD damage can range from subtle performance degradation to complete device failure. Precision integrated circuits may be more susceptible to damage because very small parametric changes could cause the device not to meet its published specifications.

## 8.11 Export Control Notice

Recipient agrees to not knowingly export or re-export, directly or indirectly, any product or technical data (as defined by the U.S., EU, and other Export Administration Regulations) including software, or any controlled product restricted by other applicable national regulations, received from Disclosing party under this Agreement, or any direct product of such technology, to any destination to which such export or re-export is restricted or prohibited by U.S. or other applicable laws, without obtaining prior authorization from U.S. Department of Commerce and other competent Government authorities to the extent required by those laws.

## 8.12 Glossary

[SLYZ022](#) — *TI Glossary*.

This glossary lists and explains terms, acronyms and definitions.

# 9 Mechanical Packaging and Orderable Information

## 9.1 Packaging Information

The following pages include mechanical packaging and orderable information. This information is the most current data available for the designated devices. This data is subject to change without notice and revision of this document. For browser-based versions of this data sheet, refer to the left-hand navigation.

**PACKAGING INFORMATION**

| Orderable Device | Status<br>(1) | Package Type | Package Drawing | Pins | Package Qty | Eco Plan<br>(2)         | Lead/Ball Finish<br>(6) | MSL Peak Temp<br>(3) | Op Te |
|------------------|---------------|--------------|-----------------|------|-------------|-------------------------|-------------------------|----------------------|-------|
| CC2650F128RGZR   | ACTIVE        | VQFN         | RGZ             | 48   | 2500        | Green (RoHS & no Sb/Br) | CU NIPDAU   Call TI     | Level-3-260C-168 HR  | -40   |
| CC2650F128RGZT   | ACTIVE        | VQFN         | RGZ             | 48   | 250         | Green (RoHS & no Sb/Br) | CU NIPDAU   Call TI     | Level-3-260C-168 HR  | -40   |
| CC2650F128RHBR   | ACTIVE        | VQFN         | RHB             | 32   | 3000        | Green (RoHS & no Sb/Br) | CU NIPDAU   Call TI     | Level-3-260C-168 HR  | -40   |
| CC2650F128RHBT   | ACTIVE        | VQFN         | RHB             | 32   | 250         | Green (RoHS & no Sb/Br) | CU NIPDAU   Call TI     | Level-3-260C-168 HR  | -40   |
| CC2650F128RSMR   | ACTIVE        | VQFN         | RSM             | 32   | 3000        | Green (RoHS & no Sb/Br) | CU NIPDAU   Call TI     | Level-3-260C-168 HR  | -40   |
| CC2650F128RSMT   | ACTIVE        | VQFN         | RSM             | 32   | 250         | Green (RoHS & no Sb/Br) | CU NIPDAU   Call TI     | Level-3-260C-168 HR  | -40   |

(1) The marketing status values are defined as follows:

**ACTIVE:** Product device recommended for new designs.

**LIFEBUY:** TI has announced that the device will be discontinued, and a lifetime-buy period is in effect.

**NRND:** Not recommended for new designs. Device is in production to support existing customers, but TI does not recommend using this part in a new design.

**PREVIEW:** Device has been announced but is not in production. Samples may or may not be available.

**OBSOLETE:** TI has discontinued the production of the device.

(2) Eco Plan - The planned eco-friendly classification: Pb-Free (RoHS), Pb-Free (RoHS Exempt), or Green (RoHS & no Sb/Br) - please check <http://www.ti.com/pr> information and additional product content details.

**TBD:** The Pb-Free/Green conversion plan has not been defined.

**Pb-Free (RoHS):** TI's terms "Lead-Free" or "Pb-Free" mean semiconductor products that are compatible with the current RoHS requirements for all 6 substances, lead not exceed 0.1% by weight in homogeneous materials. Where designed to be soldered at high temperatures, TI Pb-Free products are suitable for use in spec

**Pb-Free (RoHS Exempt):** This component has a RoHS exemption for either 1) lead-based flip-chip solder bumps used between the die and package, or 2) lead-b the die and leadframe. The component is otherwise considered Pb-Free (RoHS compatible) as defined above.

**Green (RoHS & no Sb/Br):** TI defines "Green" to mean Pb-Free (RoHS compatible), and free of Bromine (Br) and Antimony (Sb) based flame retardants (Br or S in homogeneous material)

(3) MSL, Peak Temp. - The Moisture Sensitivity Level rating according to the JEDEC industry standard classifications, and peak solder temperature.

(4) There may be additional marking, which relates to the logo, the lot trace code information, or the environmental category on the device.

(5) Multiple Device Markings will be inside parentheses. Only one Device Marking contained in parentheses and separated by a "~" will appear on a device. If a line of the previous line and the two combined represent the entire Device Marking for that device.

<sup>(6)</sup> Lead/Ball Finish - Orderable Devices may have multiple material finish options. Finish options are separated by a vertical ruled line. Lead/Ball Finish values may value exceeds the maximum column width.

**Important Information and Disclaimer:** The information provided on this page represents TI's knowledge and belief as of the date that it is provided. TI bases its provided by third parties, and makes no representation or warranty as to the accuracy of such information. Efforts are underway to better integrate information from continues to take reasonable steps to provide representative and accurate information but may not have conducted destructive testing or chemical analysis on inc TI and TI suppliers consider certain information to be proprietary, and thus CAS numbers and other limited information may not be available for release.

In no event shall TI's liability arising out of such information exceed the total purchase price of the TI part(s) at issue in this document sold by TI to Customer on an

**TAPE AND REEL INFORMATION**

**QUADRANT ASSIGNMENTS FOR PIN 1 ORIENTATION IN TAPE**

\*All dimensions are nominal

| Device         | Package Type | Package Drawing | Pins | SPQ  | Reel Diameter (mm) | Reel Width W1 (mm) | A0 (mm) | B0 (mm) | K0 (mm) | P1 (mm) | W (mm) | Pin1 Quadrant |
|----------------|--------------|-----------------|------|------|--------------------|--------------------|---------|---------|---------|---------|--------|---------------|
| CC2650F128RGZR | VQFN         | RGZ             | 48   | 2500 | 330.0              | 16.4               | 7.3     | 7.3     | 1.1     | 12.0    | 16.0   | Q2            |
| CC2650F128RGZT | VQFN         | RGZ             | 48   | 250  | 180.0              | 16.4               | 7.3     | 7.3     | 1.1     | 12.0    | 16.0   | Q2            |
| CC2650F128RHBR | VQFN         | RHB             | 32   | 3000 | 330.0              | 12.4               | 5.3     | 5.3     | 1.1     | 8.0     | 12.0   | Q2            |
| CC2650F128RHBT | VQFN         | RHB             | 32   | 250  | 180.0              | 12.4               | 5.3     | 5.3     | 1.1     | 8.0     | 12.0   | Q2            |
| CC2650F128RSMR | VQFN         | RSM             | 32   | 3000 | 330.0              | 12.4               | 4.25    | 4.25    | 1.15    | 8.0     | 12.0   | Q2            |
| CC2650F128RSMT | VQFN         | RSM             | 32   | 250  | 180.0              | 12.4               | 4.25    | 4.25    | 1.15    | 8.0     | 12.0   | Q2            |



**TAPE AND REEL BOX DIMENSIONS**

\*All dimensions are nominal

| Device         | Package Type | Package Drawing | Pins | SPQ  | Length (mm) | Width (mm) | Height (mm) |
|----------------|--------------|-----------------|------|------|-------------|------------|-------------|
| CC2650F128RGZR | VQFN         | RGZ             | 48   | 2500 | 367.0       | 367.0      | 38.0        |
| CC2650F128RGZT | VQFN         | RGZ             | 48   | 250  | 210.0       | 185.0      | 35.0        |
| CC2650F128RHBR | VQFN         | RHB             | 32   | 3000 | 367.0       | 367.0      | 35.0        |
| CC2650F128RHBT | VQFN         | RHB             | 32   | 250  | 210.0       | 185.0      | 35.0        |
| CC2650F128RSMR | VQFN         | RSM             | 32   | 3000 | 367.0       | 367.0      | 35.0        |
| CC2650F128RSMT | VQFN         | RSM             | 32   | 250  | 210.0       | 185.0      | 35.0        |

RGZ (S-PVQFN-N48)

PLASTIC QUAD FLATPACK NO-LEAD

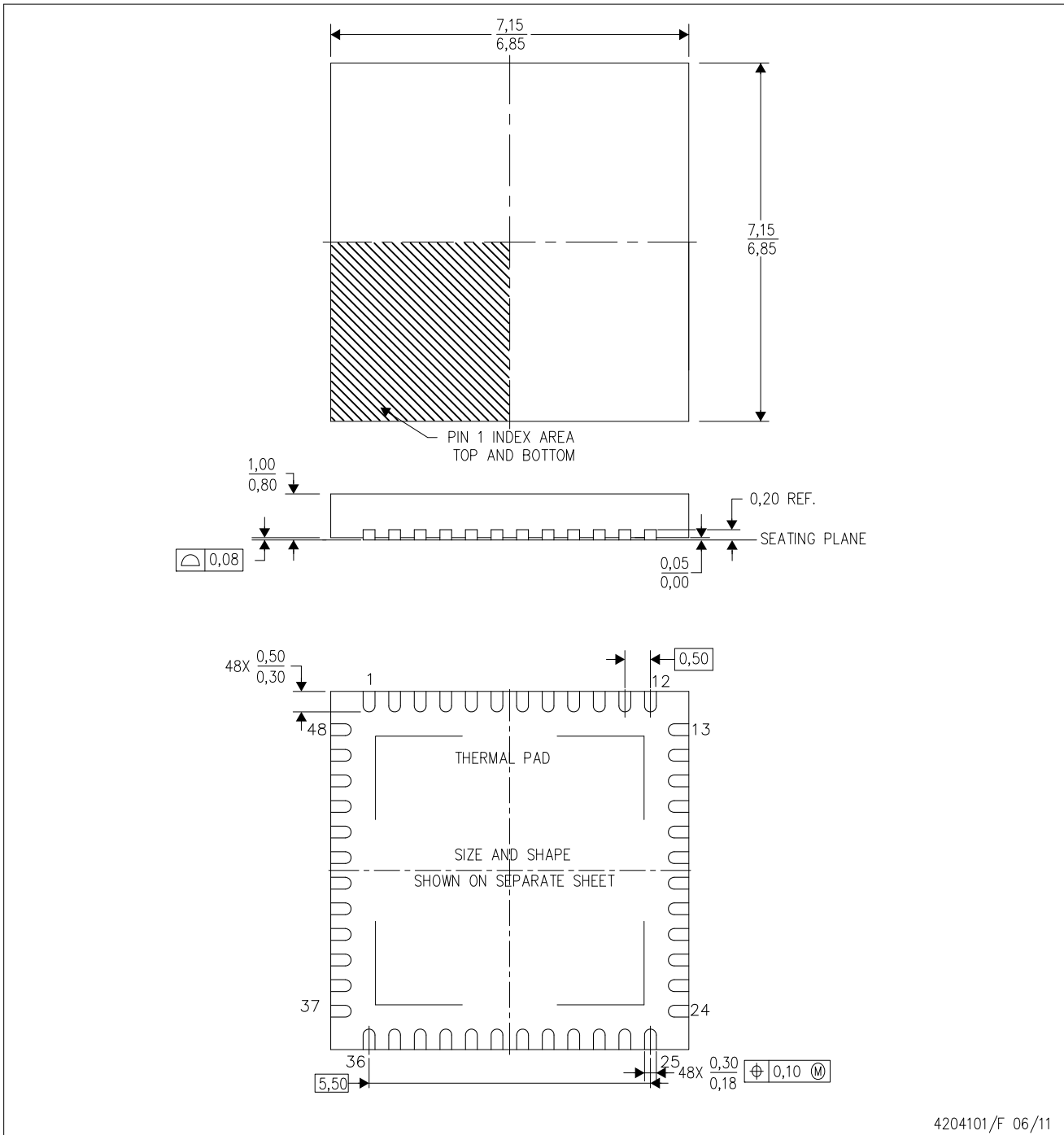

4204101/F 06/11

- NOTES:
- All linear dimensions are in millimeters. Dimensioning and tolerancing per ASME Y14.5M-1994.
  - This drawing is subject to change without notice.
  - Quad Flatpack, No-leads (QFN) package configuration.
  - The package thermal pad must be soldered to the board for thermal and mechanical performance.
  - See the additional figure in the Product Data Sheet for details regarding the exposed thermal pad features and dimensions.
  - Falls within JEDEC MO-220.

THERMAL INFORMATION

This package incorporates an exposed thermal pad that is designed to be attached directly to an external heatsink. The thermal pad must be soldered directly to the printed circuit board (PCB). After soldering, the PCB can be used as a heatsink. In addition, through the use of thermal vias, the thermal pad can be attached directly to the appropriate copper plane shown in the electrical schematic for the device, or alternatively, can be attached to a special heatsink structure designed into the PCB. This design optimizes the heat transfer from the integrated circuit (IC).

For information on the Quad Flatpack No-Lead (QFN) package and its advantages, refer to Application Report, QFN/SON PCB Attachment, Texas Instruments Literature No. SLUA271. This document is available at [www.ti.com](http://www.ti.com).

The exposed thermal pad dimensions for this package are shown in the following illustration.

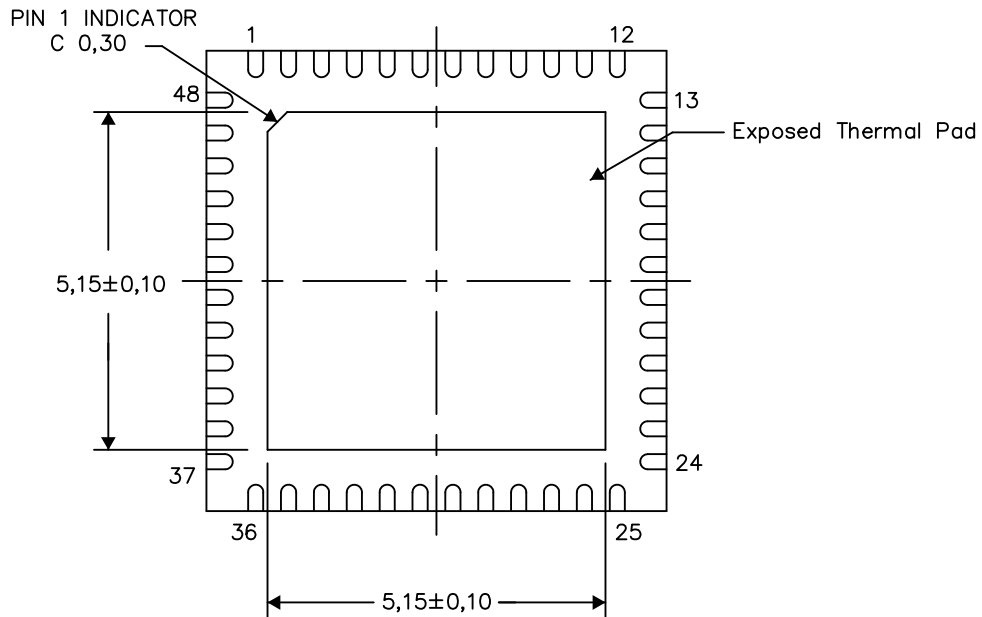

Bottom View

Exposed Thermal Pad Dimensions

4206354-2/Z 03/15

NOTE: All linear dimensions are in millimeters

RGZ (S-PVQFN-N48)

PLASTIC QUAD FLATPACK NO-LEAD

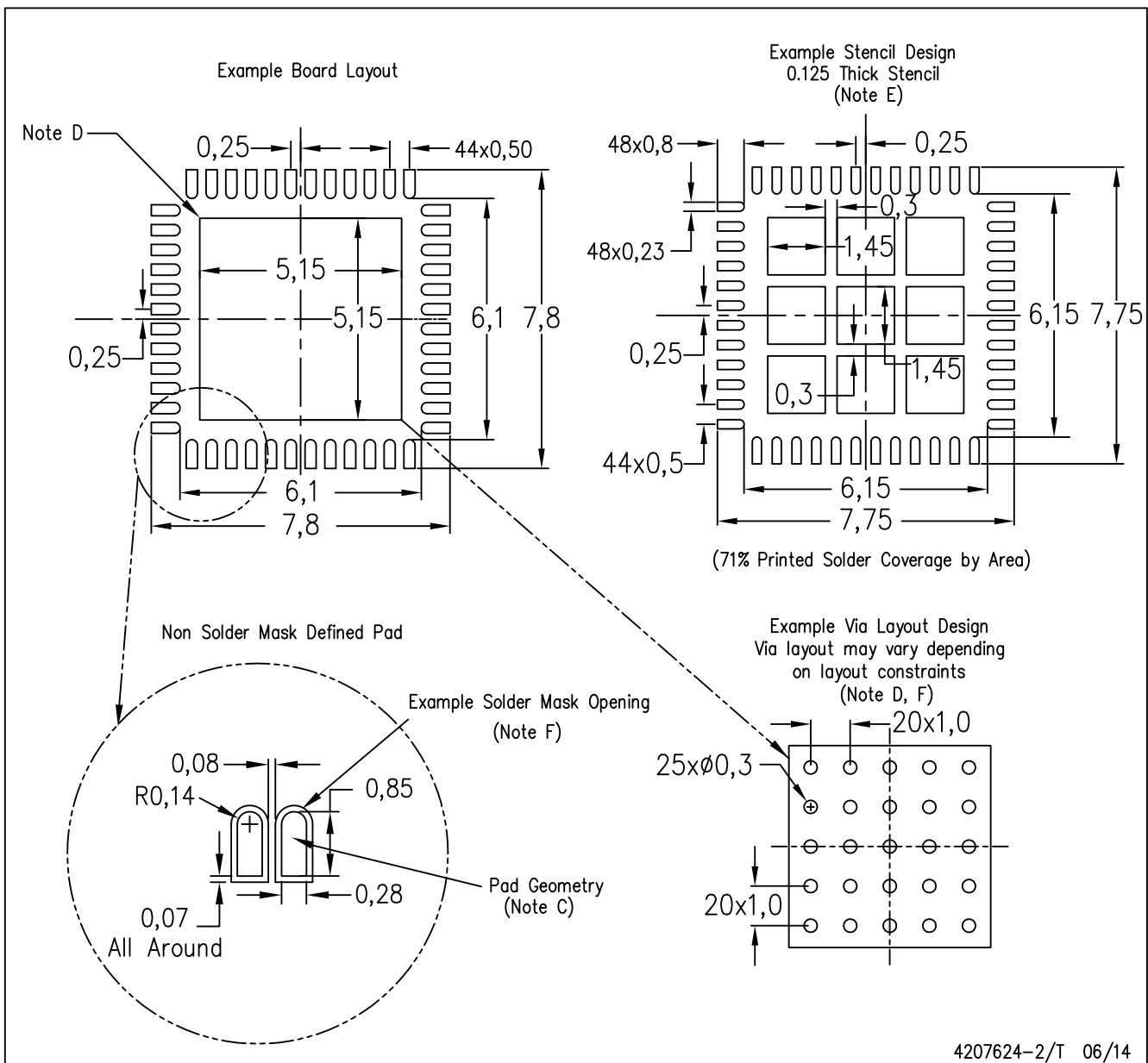

- NOTES:
- All linear dimensions are in millimeters.
  - This drawing is subject to change without notice.
  - Publication IPC-7351 is recommended for alternate designs.
  - This package is designed to be soldered to a thermal pad on the board. Refer to Application Note, Quad Flat-Pack Packages, Texas Instruments Literature No. SLUA271, and also the Product Data Sheets for specific thermal information, via requirements, and recommended board layout. These documents are available at [www.ti.com](http://www.ti.com) <<http://www.ti.com>>.
  - Laser cutting apertures with trapezoidal walls and also rounding corners will offer better paste release. Customers should contact their board assembly site for stencil design recommendations. Refer to IPC 7525 for stencil design considerations.
  - Customers should contact their board fabrication site for recommended solder mask tolerances and via tenting recommendations for vias placed in the thermal pad.

# MECHANICAL DATA

RHB (S-PVQFN-N32)

PLASTIC QUAD FLATPACK NO-LEAD

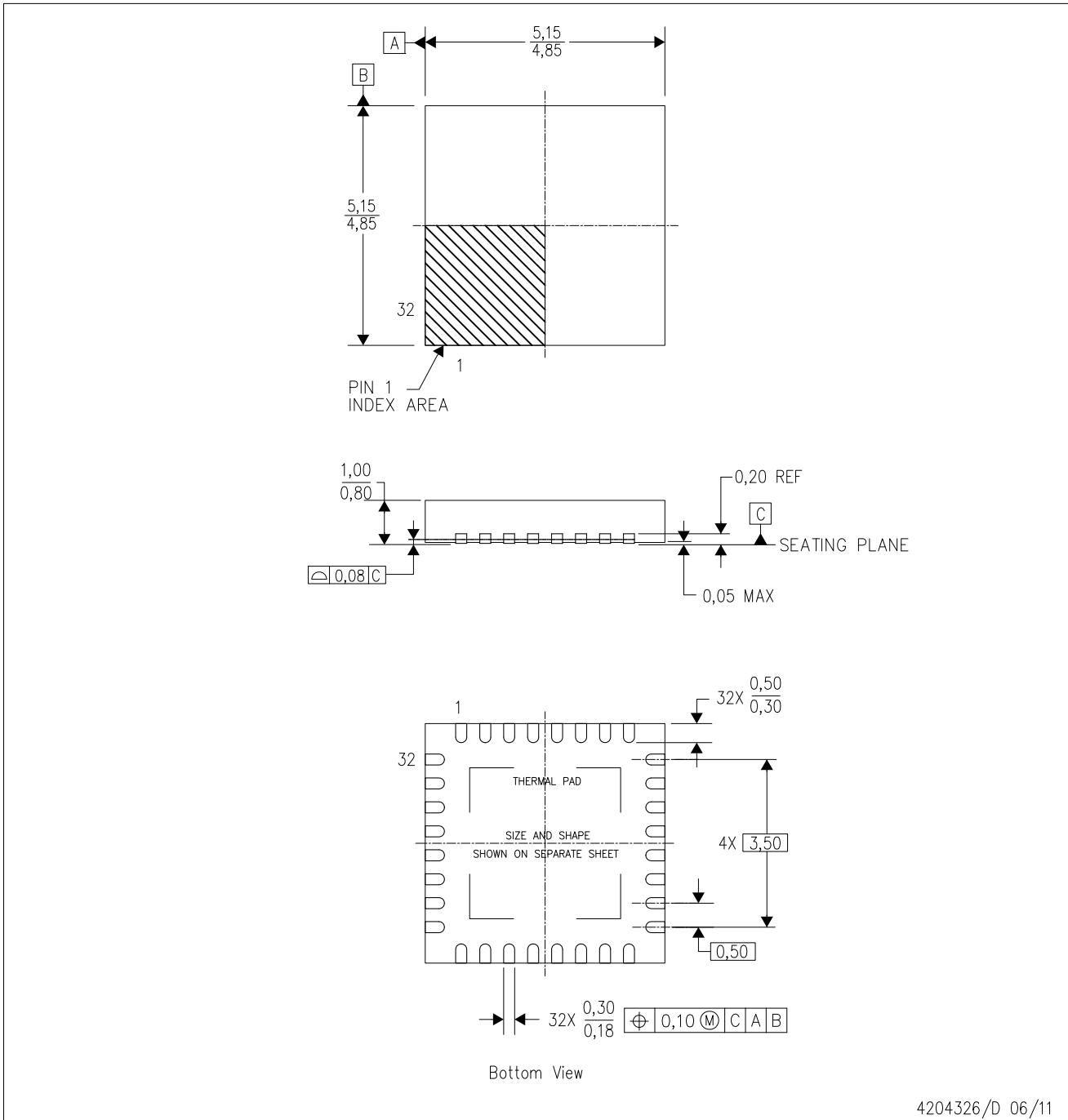

- NOTES:
- All linear dimensions are in millimeters. Dimensioning and tolerancing per ASME Y14.5M-1994.
  - This drawing is subject to change without notice.
  - QFN (Quad Flatpack No-Lead) Package configuration.
  - The package thermal pad must be soldered to the board for thermal and mechanical performance.
  - See the additional figure in the Product Data Sheet for details regarding the exposed thermal pad features and dimensions.
  - Falls within JEDEC MO-220.

## THERMAL INFORMATION

This package incorporates an exposed thermal pad that is designed to be attached directly to an external heatsink. The thermal pad must be soldered directly to the printed circuit board (PCB). After soldering, the PCB can be used as a heatsink. In addition, through the use of thermal vias, the thermal pad can be attached directly to the appropriate copper plane shown in the electrical schematic for the device, or alternatively, can be attached to a special heatsink structure designed into the PCB. This design optimizes the heat transfer from the integrated circuit (IC).

For information on the Quad Flatpack No-Lead (QFN) package and its advantages, refer to Application Report, QFN/SON PCB Attachment, Texas Instruments Literature No. SLUA271. This document is available at [www.ti.com](http://www.ti.com).

The exposed thermal pad dimensions for this package are shown in the following illustration.

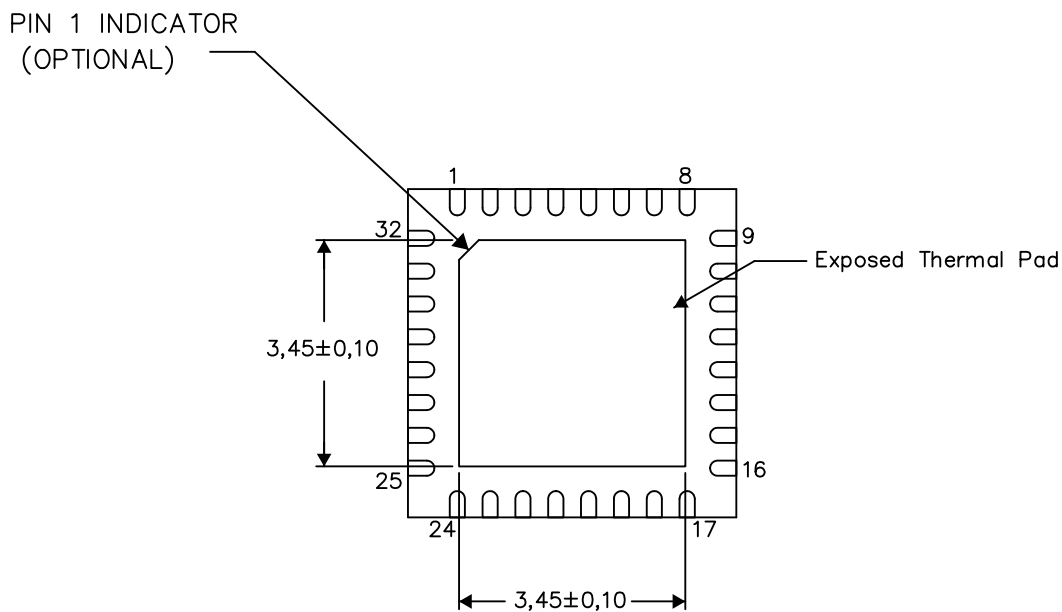

Bottom View

Exposed Thermal Pad Dimensions

4206356-2/AC 05/15

NOTE: A. All linear dimensions are in millimeters

RHB (S-PVQFN-N32)

PLASTIC QUAD FLATPACK NO-LEAD

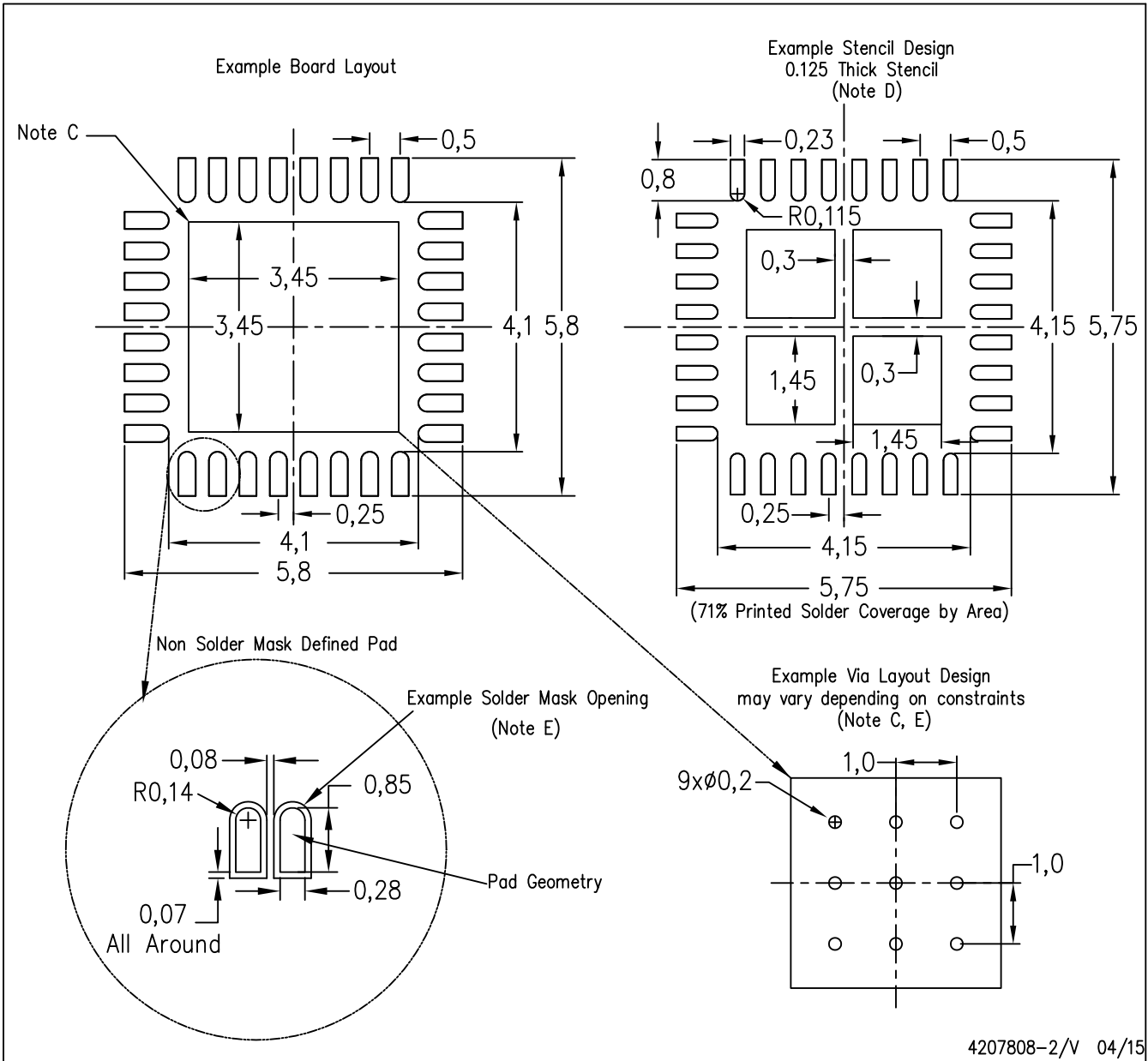

- NOTES:
- All linear dimensions are in millimeters.
  - This drawing is subject to change without notice.
  - This package is designed to be soldered to a thermal pad on the board. Refer to Application Note, Quad Flat-Pack Packages, Texas Instruments Literature No. SLUA271, and also the Product Data Sheets for specific thermal information, via requirements, and recommended board layout. These documents are available at [www.ti.com](http://www.ti.com) <<http://www.ti.com>>.
  - Laser cutting apertures with trapezoidal walls and also rounding corners will offer better paste release. Customers should contact their board assembly site for stencil design recommendations. Refer to IPC 7525 for stencil design considerations.
  - Customers should contact their board fabrication site for recommended solder mask tolerances and via tenting recommendations for any larger diameter vias placed in the thermal pad.

RSM (S-PVQFN-N32)

PLASTIC QUAD FLATPACK NO-LEAD

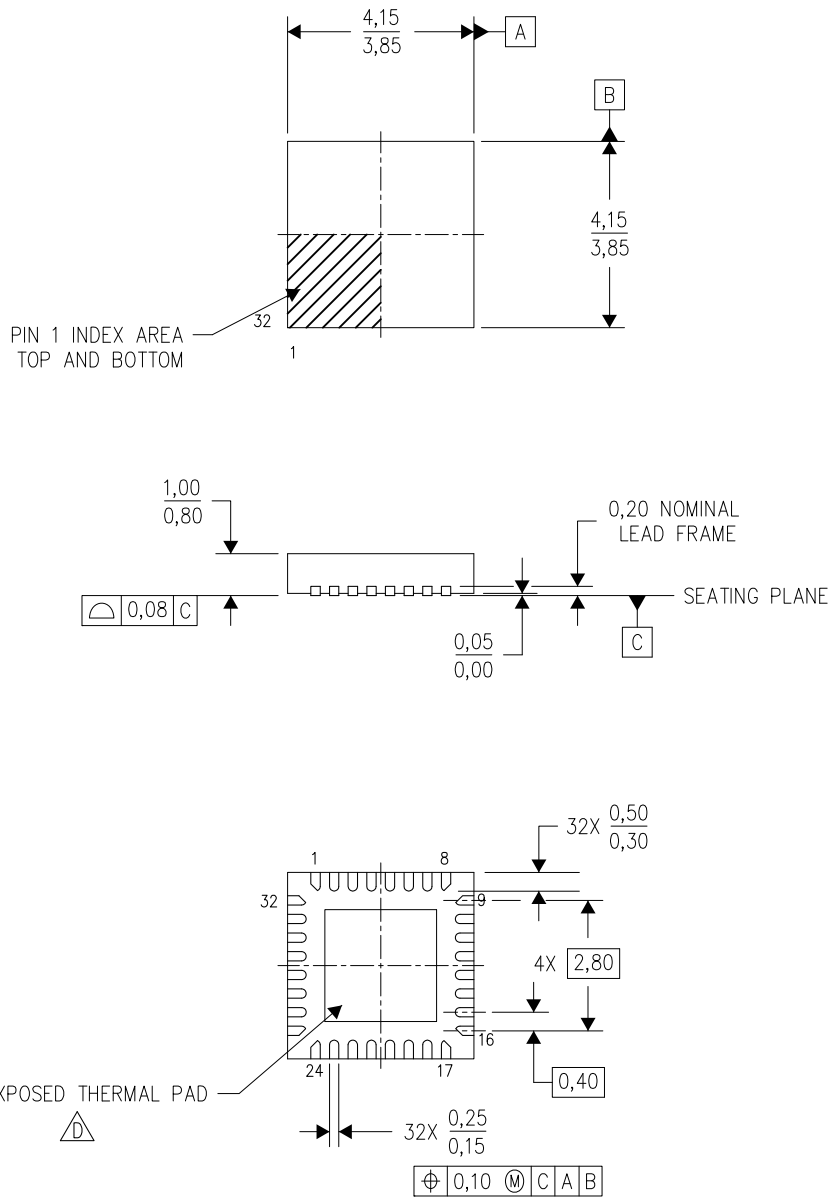

4207560/B 03/10

- NOTES:
- A. All linear dimensions are in millimeters. Dimensioning and tolerancing per ASME Y14.5M-1994.
  - B. This drawing is subject to change without notice.
  - C. QFN (Quad Flatpack No-Lead) Package configuration.
  -  The package thermal pad must be soldered to the board for thermal and mechanical performance. See the Product Data Sheet for details regarding the exposed thermal pad dimensions.



RSM (S-PVQFN-N32)

PLASTIC QUAD FLATPACK NO-LEAD

## THERMAL INFORMATION

This package incorporates an exposed thermal pad that is designed to be attached directly to an external heatsink. The thermal pad must be soldered directly to the printed circuit board (PCB). After soldering, the PCB can be used as a heatsink. In addition, through the use of thermal vias, the thermal pad can be attached directly to the appropriate copper plane shown in the electrical schematic for the device, or alternatively, can be attached to a special heatsink structure designed into the PCB. This design optimizes the heat transfer from the integrated circuit (IC).

For information on the Quad Flatpack No-Lead (QFN) package and its advantages, refer to Application Report, QFN/SON PCB Attachment, Texas Instruments Literature No. SLUA271. This document is available at [www.ti.com](http://www.ti.com).

The exposed thermal pad dimensions for this package are shown in the following illustration.

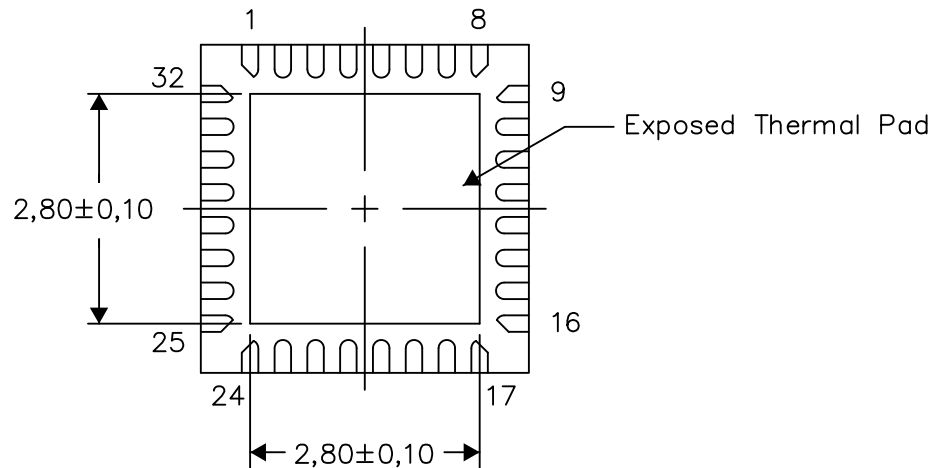

Bottom View

Exposed Thermal Pad Dimensions

4207868-2/1 07/14

NOTE: All linear dimensions are in millimeters

RSM (S-PVQFN-N32)

PLASTIC QUAD FLATPACK NO-LEAD

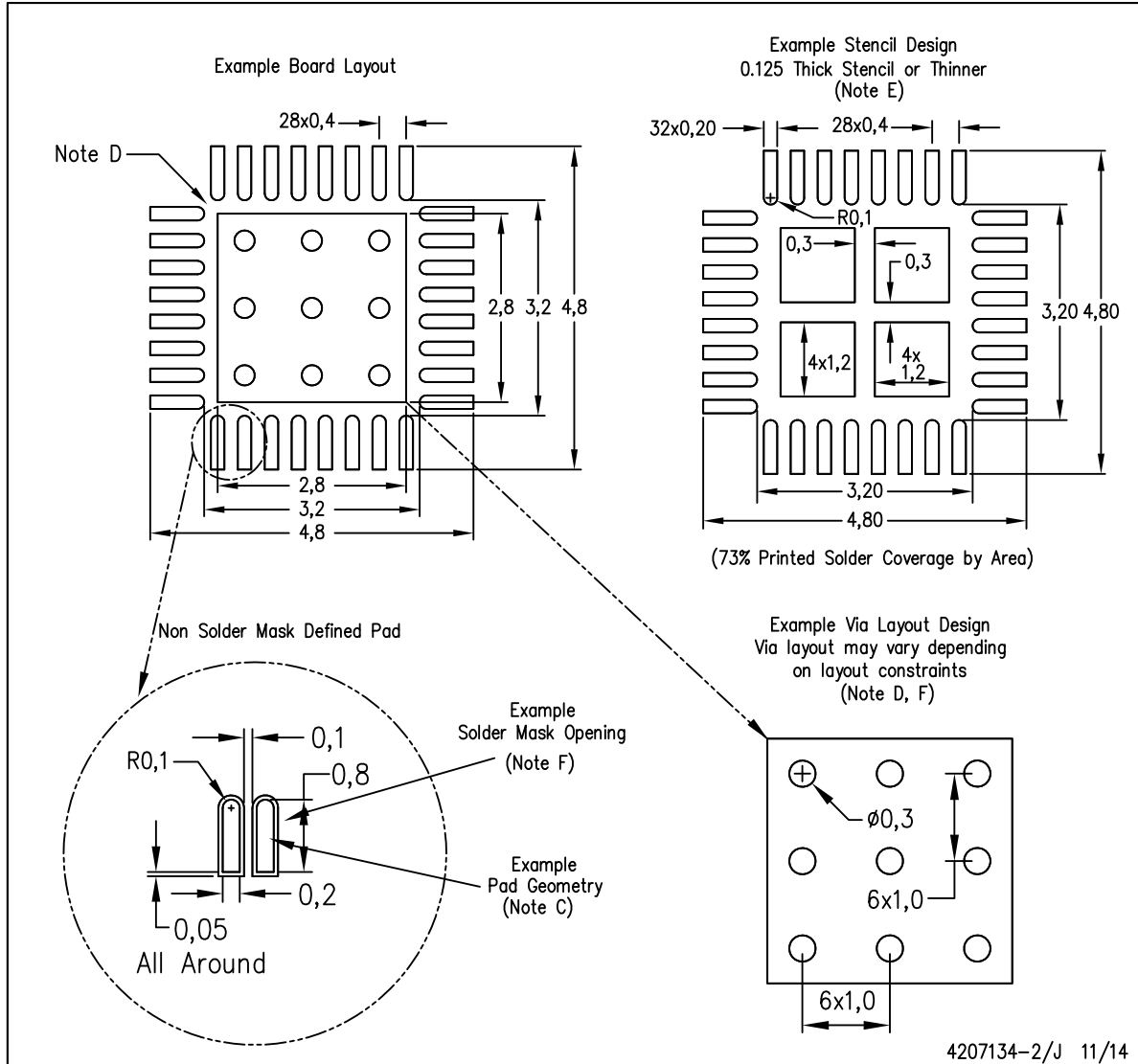

- NOTES:
- All linear dimensions are in millimeters.
  - This drawing is subject to change without notice.
  - Publication IPC-7351 is recommended for alternate designs.
  - This package is designed to be soldered to a thermal pad on the board. Refer to Application Note, Quad Flat-Pack Packages, Texas Instruments Literature No. SLUA271, and also the Product Data Sheets for specific thermal information, via requirements, and recommended board layout. These documents are available at [www.ti.com](http://www.ti.com) <<http://www.ti.com>>.
  - Laser cutting apertures with trapezoidal walls and also rounding corners will offer better paste release. Customers should contact their board assembly site for stencil design recommendations. Refer to IPC 7525 for stencil design considerations.
  - Customers should contact their board fabrication site for recommended solder mask tolerances and via tenting recommendations for vias placed in the thermal pad.

## IMPORTANT NOTICE

Texas Instruments Incorporated and its subsidiaries (TI) reserve the right to make corrections, enhancements, improvements and other changes to its semiconductor products and services per JESD46, latest issue, and to discontinue any product or service per JESD48, latest issue. Buyers should obtain the latest relevant information before placing orders and should verify that such information is current and complete. All semiconductor products (also referred to herein as "components") are sold subject to TI's terms and conditions of sale supplied at the time of order acknowledgment.

TI warrants performance of its components to the specifications applicable at the time of sale, in accordance with the warranty in TI's terms and conditions of sale of semiconductor products. Testing and other quality control techniques are used to the extent TI deems necessary to support this warranty. Except where mandated by applicable law, testing of all parameters of each component is not necessarily performed.

TI assumes no liability for applications assistance or the design of Buyers' products. Buyers are responsible for their products and applications using TI components. To minimize the risks associated with Buyers' products and applications, Buyers should provide adequate design and operating safeguards.

TI does not warrant or represent that any license, either express or implied, is granted under any patent right, copyright, mask work right, or other intellectual property right relating to any combination, machine, or process in which TI components or services are used. Information published by TI regarding third-party products or services does not constitute a license to use such products or services or a warranty or endorsement thereof. Use of such information may require a license from a third party under the patents or other intellectual property of the third party, or a license from TI under the patents or other intellectual property of TI.

Reproduction of significant portions of TI information in TI data books or data sheets is permissible only if reproduction is without alteration and is accompanied by all associated warranties, conditions, limitations, and notices. TI is not responsible or liable for such altered documentation. Information of third parties may be subject to additional restrictions.

Resale of TI components or services with statements different from or beyond the parameters stated by TI for that component or service voids all express and any implied warranties for the associated TI component or service and is an unfair and deceptive business practice. TI is not responsible or liable for any such statements.

Buyer acknowledges and agrees that it is solely responsible for compliance with all legal, regulatory and safety-related requirements concerning its products, and any use of TI components in its applications, notwithstanding any applications-related information or support that may be provided by TI. Buyer represents and agrees that it has all the necessary expertise to create and implement safeguards which anticipate dangerous consequences of failures, monitor failures and their consequences, lessen the likelihood of failures that might cause harm and take appropriate remedial actions. Buyer will fully indemnify TI and its representatives against any damages arising out of the use of any TI components in safety-critical applications.

In some cases, TI components may be promoted specifically to facilitate safety-related applications. With such components, TI's goal is to help enable customers to design and create their own end-product solutions that meet applicable functional safety standards and requirements. Nonetheless, such components are subject to these terms.

No TI components are authorized for use in FDA Class III (or similar life-critical medical equipment) unless authorized officers of the parties have executed a special agreement specifically governing such use.

Only those TI components which TI has specifically designated as military grade or "enhanced plastic" are designed and intended for use in military/aerospace applications or environments. Buyer acknowledges and agrees that any military or aerospace use of TI components which have **not** been so designated is solely at the Buyer's risk, and that Buyer is solely responsible for compliance with all legal and regulatory requirements in connection with such use.

TI has specifically designated certain components as meeting ISO/TS16949 requirements, mainly for automotive use. In any case of use of non-designated products, TI will not be responsible for any failure to meet ISO/TS16949.

### Products

|                              |  |
|------------------------------|--|
| Audio                        | <a href="http://www.ti.com/audio">www.ti.com/audio</a>                               |
| Amplifiers                   | <a href="http://amplifier.ti.com">amplifier.ti.com</a>                               |
| Data Converters              | <a href="http://dataconverter.ti.com">dataconverter.ti.com</a>                       |
| DLP® Products                | <a href="http://www.dlp.com">www.dlp.com</a>   |
| DSP                          | <a href="http://dsp.ti.com">dsp.ti.com</a>   |
| Clocks and Timers            | <a href="http://www.ti.com/clocks">www.ti.com/clocks</a>                             |
| Interface                    | <a href="http://interface.ti.com">interface.ti.com</a>                               |
| Logic                        | <a href="http://logic.ti.com">logic.ti.com</a>                                       |
| Power Mgmt                   | <a href="http://power.ti.com">power.ti.com</a>                                       |
| Microcontrollers             | <a href="http://microcontroller.ti.com">microcontroller.ti.com</a>                   |
| RFID                         | <a href="http://www.ti-rfid.com">www.ti-rfid.com</a>                                 |
| OMAP Applications Processors | <a href="http://www.ti.com/omap">www.ti.com/omap</a>                                 |
| Wireless Connectivity        | <a href="http://www.ti.com/wirelessconnectivity">www.ti.com/wirelessconnectivity</a> |

### Applications

|                               |  |
|-------------------------------|--|
| Automotive and Transportation | <a href="http://www.ti.com/automotive">www.ti.com/automotive</a>                         |
| Communications and Telecom    | <a href="http://www.ti.com/communications">www.ti.com/communications</a>                 |
| Computers and Peripherals     | <a href="http://www.ti.com/computers">www.ti.com/computers</a>                           |
| Consumer Electronics          | <a href="http://www.ti.com/consumer-apps">www.ti.com/consumer-apps</a>                   |
| Energy and Lighting           | <a href="http://www.ti.com/energy">www.ti.com/energy</a>                                 |
| Industrial                    | <a href="http://www.ti.com/industrial">www.ti.com/industrial</a>                         |
| Medical                       | <a href="http://www.ti.com/medical">www.ti.com/medical</a>                               |
| Security                      | <a href="http://www.ti.com/security">www.ti.com/security</a>                             |
| Space, Avionics and Defense   | <a href="http://www.ti.com/space-avionics-defense">www.ti.com/space-avionics-defense</a> |
| Video and Imaging             | <a href="http://www.ti.com/video">www.ti.com/video</a>                                   |

### TI E2E Community

[e2e.ti.com](http://e2e.ti.com)