



**MULTI-INNO TECHNOLOGY CO., LTD.**

# **LCD MODULE SPECIFICATION**

**Model : MI0350CT-3**

|               |  |
|---------------|--|
| Revision      |  |
| Engineering   |  |
| Date          |  |
| Our Reference |  |

**Table of Contents**

| <b>NO.</b> | <b>Item</b>                        | <b>Page</b> |
|------------|------------------------------------|-------------|
|            | Cover Sheet                        | 1           |
|            | Table of Contents                  | 2           |
|            | Record of Revision                 | 3           |
| 1          | General Specifications             | 4           |
| 2          | Input / Output Terminals           | 5           |
| 3          | Absolute Maximum Ratings           | 8           |
| 4          | Electrical Characteristics         | 9           |
| 5          | Timing Chart                       | 10          |
| 6          | Optical Characteristics            | 16          |
| 7          | Environmental / Reliability Tests  | 20          |
| 8          | Mechanical Drawing                 | 21          |
| 9          | Packing Drawing                    | 22          |
| 10         | Precautions for Use of LCD Modules | 23          |



**1 GENERAL SPECIFICATIONS**

| <b>Feature</b>                    |                                | <b>Spec</b>            |
|-----------------------------------|--------------------------------|------------------------|
| <b>Display Spec.</b>              | Size                           | 3.5"                   |
|                                   | Resolution                     | 320(RGB) X 240         |
|                                   | Interface                      | RGB/CCIR656/601        |
|                                   | Color Depth                    | 24bit                  |
|                                   | Technology type                | a-si                   |
|                                   | Pixel pitch (mm)               | 0.219 x 0.219          |
|                                   | Display colors                 | 16.7M dithering        |
|                                   | Pixel Configuration            | R.G.B. Vertical Stripe |
|                                   | Display Mode                   | TM with Normally White |
|                                   | Surface Treatment              | Anti-Glare , 3H        |
|                                   | Viewing direction              | 12 o'clock             |
|                                   | Gray Scale Inversion Direction | 6 o'clock              |
| <b>Mechanical Characteristics</b> | LCM (W x H x D) (mm)           | 76.9 x 63.9 x 4.0      |
|                                   | Active Area(mm)                | 70.08 x 52.56          |
|                                   | With /Without TSP              | With TSP               |
|                                   | Weight (gram)                  | TBD.                   |
|                                   | LED Numbers                    | 6 LEDs Serial          |
|                                   | Driver IC                      | Novatek NT39016D       |

**Note 1 : Viewing direction for best image quality is different from TFT definition, there is a 180 degree shift.**

**Note 2: Requirements on Environmental Protection: RoHS**



## 2 INPUT/OUTPUT TERMINALS

### 2.1 TFT LCD Panel

| No  | Symbol      | I/O | Description | Remark   |
|-----|-------------|-----|-------------|----------|
| 1,2 | LED_Cathode | I   | LED_Cathode | Note 2-1 |
| 3,4 | LED_Anode   | I   | LED_Anode   | Note 2-1 |
| 5   | NC          | -   | No Connect  |          |
| 6   | RESET       | I   | Reset       |          |
| 7   | NC          | -   | No Connect  |          |
| 8   | YU          | I   | Y_Up        |          |
| 9   | XR          | I   | X_Right     |          |
| 10  | YD          | I   | Y_Bottom    |          |
| 11  | XL          | I   | X_Left      |          |
| 12  | D00         | I   | Data 00     | Note 2-2 |
| 13  | D01         | I   | Data 01     | Note 2-2 |
| 14  | D02         | I   | Data 02     | Note 2-2 |
| 15  | D03         | I   | Data 03     | Note 2-2 |
| 16  | D04         | I   | Data 04     | Note 2-2 |
| 17  | D05         | I   | Data 05     | Note 2-2 |
| 18  | D06         | I   | Data 06     | Note 2-2 |
| 19  | D07         | I   | Data 07     | Note 2-2 |
| 20  | D08         | I   | Data 08     | Note 2-2 |
| 21  | D09         | I   | Data 09     | Note 2-2 |
| 22  | D10         | I   | Data 10     | Note 2-2 |
| 23  | D11         | I   | Data 11     | Note 2-2 |
| 24  | D12         | I   | Data 12     | Note 2-2 |
| 25  | D13         | I   | Data 13     | Note 2-2 |
| 26  | D14         | I   | Data 14     | Note 2-2 |
| 27  | D15         | I   | Data 15     | Note 2-2 |
| 28  | D16         | I   | Data 16     | Note 2-2 |
| 29  | D17         | I   | Data 17     | Note 2-2 |
| 30  | D18         | I   | Data 18     | Note 2-2 |
| 31  | D19         | I   | Data 19     | Note 2-2 |
| 32  | D20         | I   | Data 20     | Note 2-2 |
| 33  | D21         | I   | Data 21     | Note 2-2 |
| 34  | D22         | I   | Data 22     | Note 2-2 |
| 35  | D23         | I   | Data 23     | Note 2-2 |

|    |       |     |                                |
|----|-------|-----|--------------------------------|
| 36 | HSYNC | I   | Horizontal Synchronous Signal  |
| 37 | VSYNC | I   | Vertical Synchronous Signal    |
| 38 | CLK   | I   | Data Clock                     |
| 39 | NC    | -   | No Connect                     |
| 40 | NC    | -   | No Connect                     |
| 41 | VDD   | P   | power supply                   |
| 42 | VDD   | P   | power supply                   |
| 43 | SPENA | I   | Serial port data enable signal |
| 44 | NC    | -   | No Connect                     |
| 45 | NC    | -   | No Connect                     |
| 46 | NC    | -   | No Connect                     |
| 47 | NC    | -   | No Connect                     |
| 48 | NC    | -   | No Connect                     |
| 49 | SPCK  | I   | SPI Serial Clock               |
| 50 | SPDA  | I/O | SPI Serial Data Input/output   |
| 51 | NC    | -   | No Connect                     |
| 52 | DEN   | I   | Data enabling signal           |
| 53 | GND   | P   | Ground                         |
| 54 | GND   | P   | Ground                         |

I: input    O: output    P: power

Note 2-1: The figure below shows the connection of LED

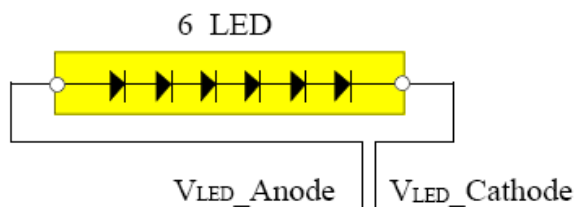

Note 2-2:

| Mode       | D(23:16) | D(15:8) | D(7:0) | HSYNC | VSYNC | DEN              |
|------------|----------|---------|--------|-------|-------|------------------|
| CCIR 656   | D(23:16) | GND     | GND    | NC    | NC    | NC               |
| CCIR 601   | D(23:16) | GND     | GND    | HSYNC | VSYNC | NC               |
| 8 Bit RGB  | D(23:16) | GND     | GND    | HSYNC | VSYNC | NC for HV mode   |
|            |          |         |        |       |       | DEN for DEN mode |
| 24 Bit RGB | R(7:0)   | G(7:0)  | B(7:0) | HSYNC | VSYNC | NC for HV mode   |
|            |          |         |        |       |       | DEN for DEN mode |

**3 ABSOLUTE MAXIMUM RATINGS**

Ta = 25°C

| Item                       | Symbol           | MIN  | MAX | Unit | Remark  |
|----------------------------|------------------|------|-----|------|---------|
| Power Supply Voltage       | VDD              | -0.3 | 5.0 | V    |         |
| Back Light Forward Current | I <sub>LED</sub> |      | 25  | mA   | One LED |
| Operating Temperature      | T <sub>OPR</sub> | -20  | 60  | °C   |         |
| Storage Temperature        | T <sub>STG</sub> | -30  | 70  | °C   |         |

**4 ELECTRICAL CHARACTERISTICS**

## 4.1. Driving TFT LCD Panel

GND=0V, Ta=25°C

| Item                             | Symbol           | MIN      | TYP    | MAX | Unit   | Remark |  |
|----------------------------------|------------------|----------|--------|-----|--------|--------|--|
| Power Supply Voltage             | VDD              | 3.0      | 3.3    | 3.6 | V      |        |  |
| Input Signal Voltage             | Low Level        | $V_{IL}$ | 0      |     | 0.3VCC | V      |  |
|                                  | High Level       | $V_{IH}$ | 0.7VCC |     | VCC    | V      |  |
| (Panel+LSI)<br>Power Consumption | Black Mode(60HZ) |          | 35     |     |        | mW     |  |
|                                  | Sleeping Mode    |          | TBD    |     |        | mW     |  |

## 4.2 Driving Backlight

Ta=25°C

| Item                        | Symbol   | MIN  | TYP  | MAX  | Unit | Remark |
|-----------------------------|----------|------|------|------|------|--------|
| Forward Current             | $I_F$    | --   | 20   | 25   | mA   |        |
| Forward Current Voltage     | $V_F$    | 16.8 | 19.2 | 21.6 | V    |        |
| Backlight Power Consumption | $W_{BL}$ | --   | 384  | --   | mW   |        |



4.3. Block Diagram

LCD module diagram

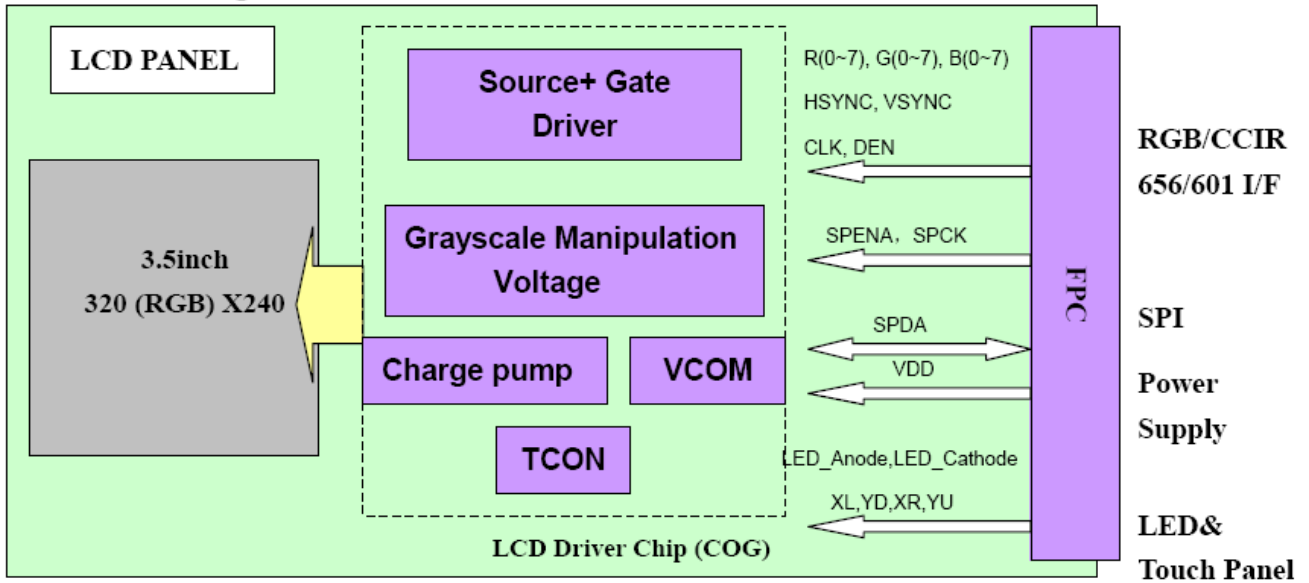

## 5 TIMING CHART

### 5.1 AC Electrical Characteristics (VDD=3.3V, GND= 0V, Ta=25°C)

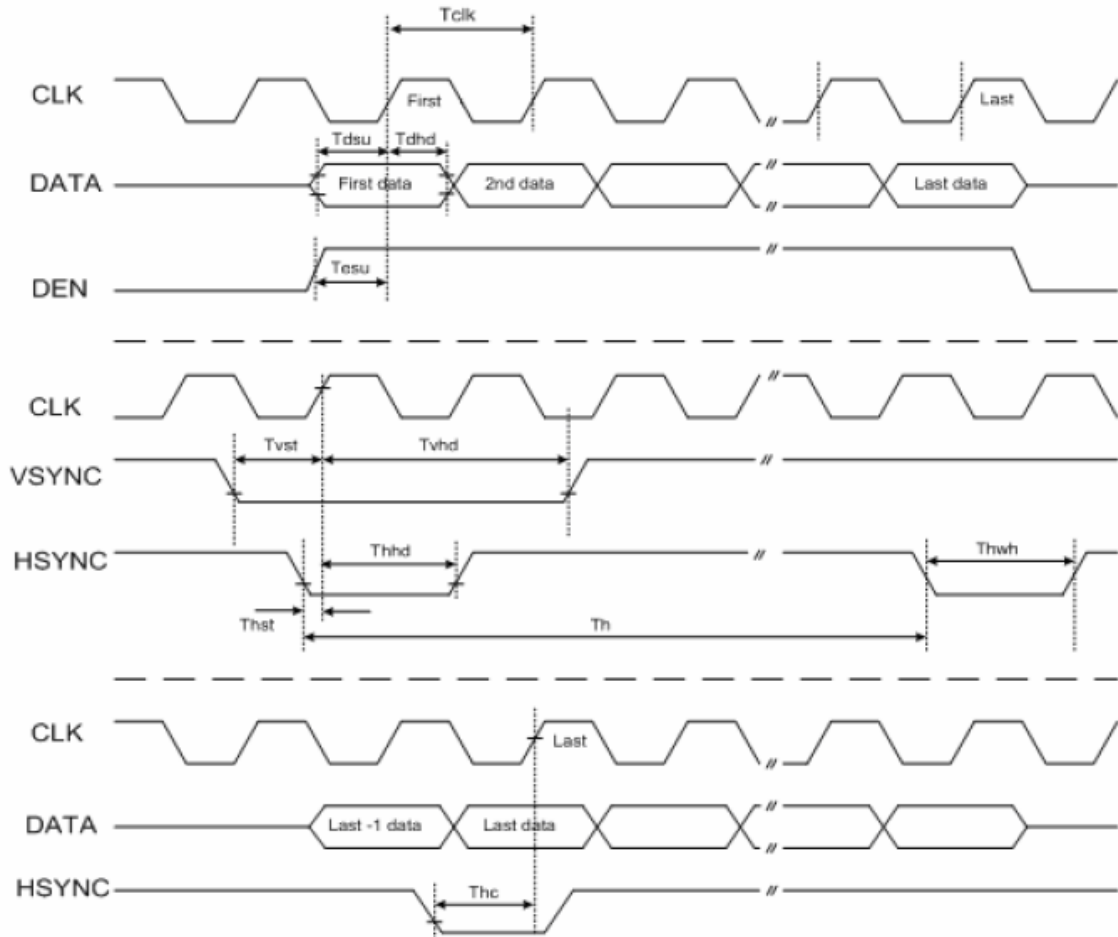

| Parameter         | Symbol | Min. | Typ.  | Max. | Unit | Conditions      |
|-------------------|--------|------|-------|------|------|-----------------|
| CLK clock time    | Tclk   | -    | -     | 35.7 | ns   | CLK=28MHz       |
| CLK pulse duty    | Tchw   | 40   | 50    | 60   | %    | Tclk            |
| HSYNC to CLK      | Thc    | -    | -     | 1    | CLK  |                 |
| HSYNC width       | Thwh   | 1    | -     | -    | CLK  |                 |
| VSYNC width       | Tvwh   | 1    | -     | -    | Th   |                 |
| HSYNC period time | Th     | 60   | 63.56 | 67   | us   |                 |
| VSYNC setup time  | Tvst   | 12   | -     | -    | ns   |                 |
| VSYNC hold time   | Tvhd   | 12   | -     | -    | ns   |                 |
| HSYNC setup time  | Thst   | 12   | -     | -    | ns   |                 |
| HSYNC hold time   | Thhd   | 12   | -     | -    | ns   |                 |
| Data set-up time  | Tdsu   | 12   | -     | -    | ns   | D[23:00] to CLK |
| Data hold time    | Tdhd   | 12   | -     | -    | ns   | D[23:00] to CLK |
| DEN setup time    | Tesu   | 12   | -     | -    | ns   | DEN to CLK      |

## 5.2 24 bit RGB mode for 320RGB x 240

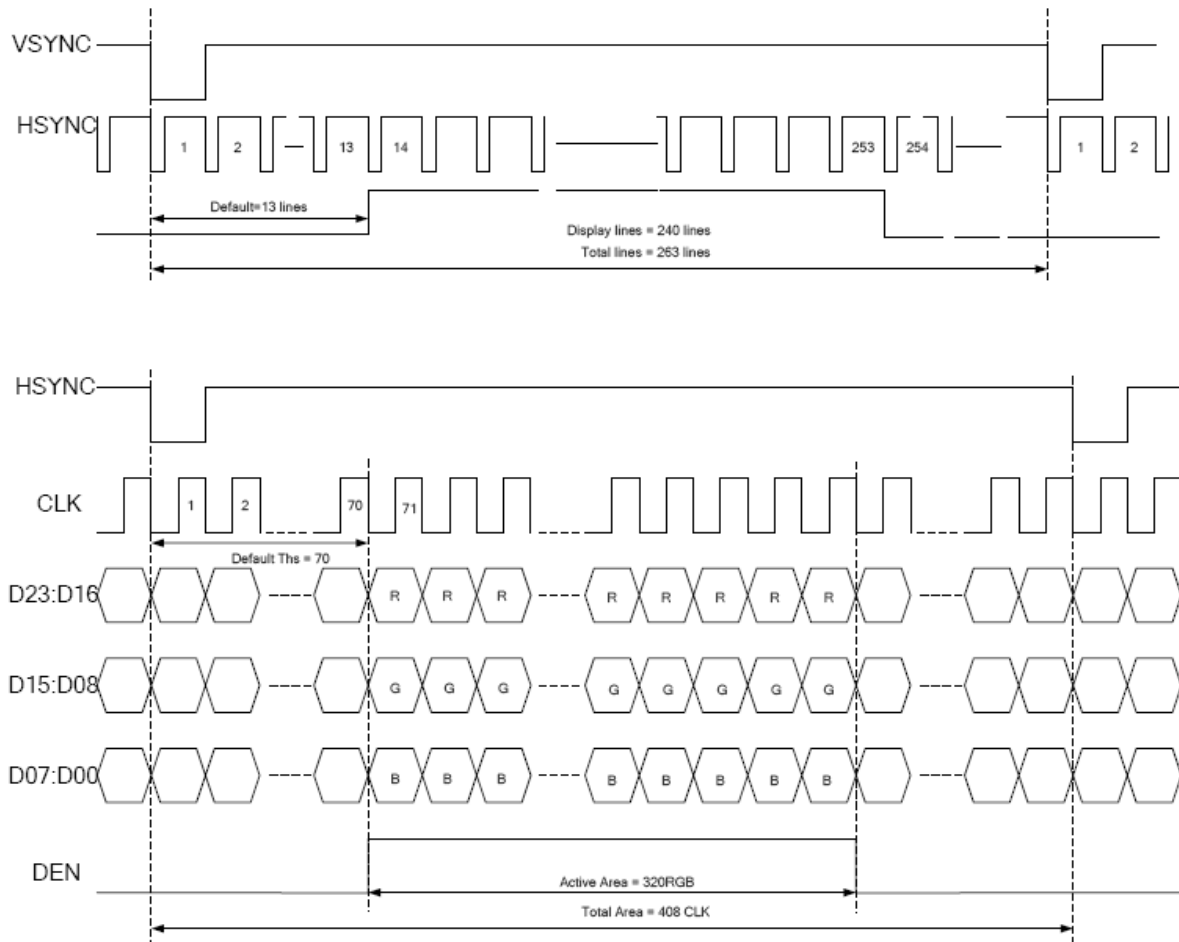

| Parameter                                | Symbol | Min. | Typ. | Max. | Unit | Conditions   |
|--|--------|------|------|------|------|--------------|
| CLK frequency                            | Fclk   | -    | 6.4  | -    | MHz  | VDD=3.0~3.6V |
| CLK cycle time                           | Tclk   | -    | 156  | -    | ns   |              |
| Time that HSYNC to 1'st data input(NTSC) | Ths    | 40   | 70   | 255  | CLK  |              |

### 5.3 8 bit RGB mode for 320RGB x 240

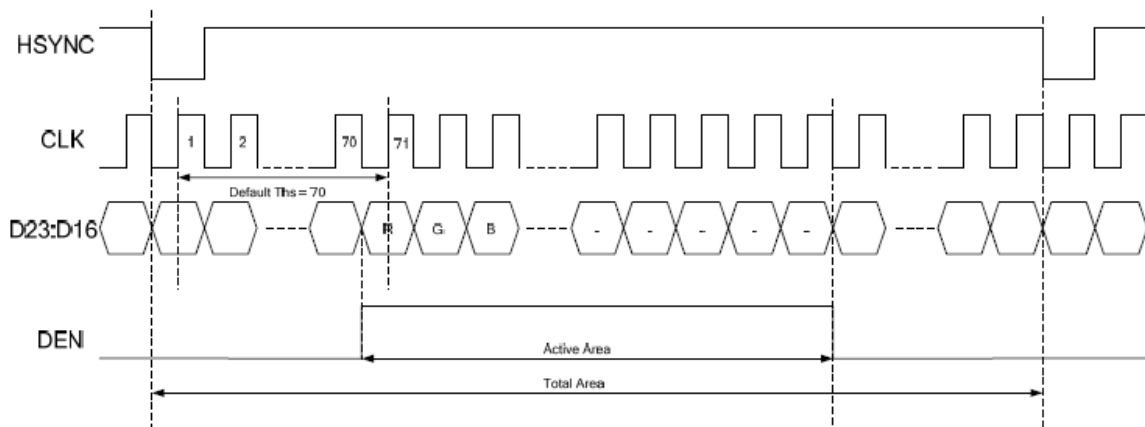

| Parameter                                | Symbol | Min. | Typ. | Max. | Unit | Conditions   |
|--|--------|------|------|------|------|--------------|
| CLK frequency                            | Fclk   | -    | 27   | -    | MHz  | VDD=3.0~3.6V |
| CLK cycle time                           | Tclk   | -    | 37   | -    | ns   |              |
| Time that HSYNC to 1'st data input(NTSC) | Ths    | 35   | 70   | 255  | CLK  |              |

### 5.4 ITU-R BT 601

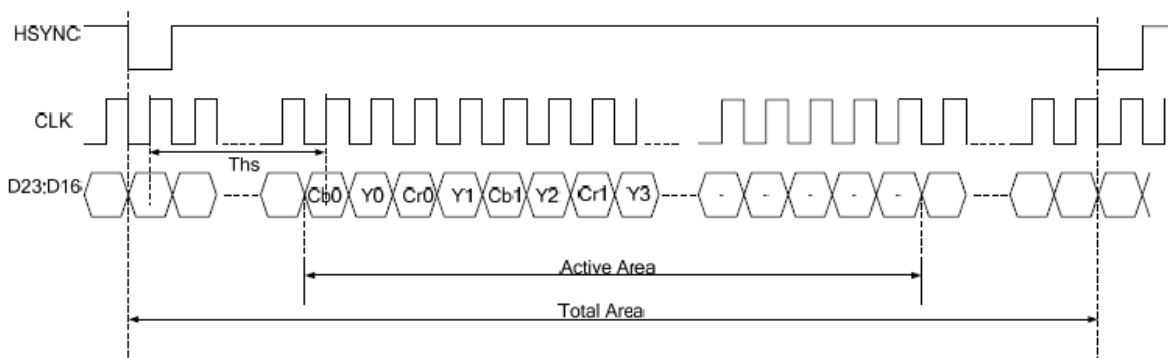

| Parameter                                | Symbol | Min. | Typ.     | Max. | Unit | Conditions   |
|--|--------|------|----------|------|------|--------------|
| CLK frequency                            | Fclk   | -    | 24.54/27 | -    | MHz  | VDD=3.0~3.6V |
| CLK cycle time                           | Tclk   | -    | 40/37    | -    | ns   |              |
| Time from HSYNC to 1'st data input(PAL)  | Ths    | 128  | 264      | -    | CLK  |              |
| Time from HSYNC to 1'st data input(NTSC) | Ths    | 128  | 244      | -    | CLK  |              |

### 5.5 ITU-R BT 656

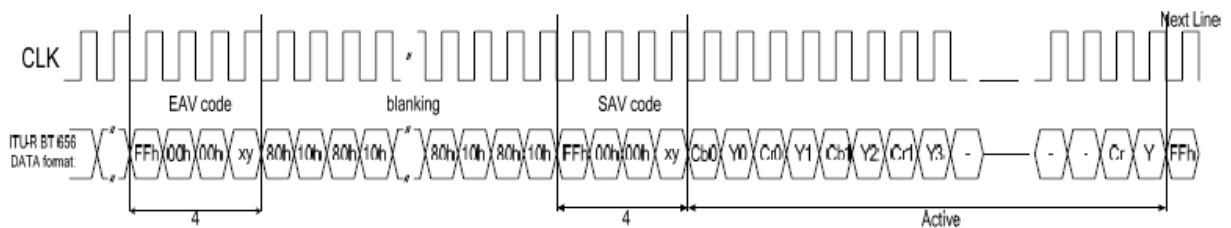

| Parameter                               | Symbol | Min. | Typ. | Max. | Unit | Conditions   |
|---|--------|------|------|------|------|--------------|
| CLK frequency                           | Fclk   | -    | 27   | -    | MHz  | VDD=3.0~3.6V |
| CLK cycle time                          | Tclk   | -    | 37   | -    | ns   |              |
| Time from EAV to 1'st data input(PAL)   | Ths    | 128  | 288  | -    | CLK  |              |
| Time from EAV to 1'st data input (NTSC) | Ths    | 128  | 276  | -    | CLK  |              |

### 5.6 3-Wire Serial Communication AC Timing

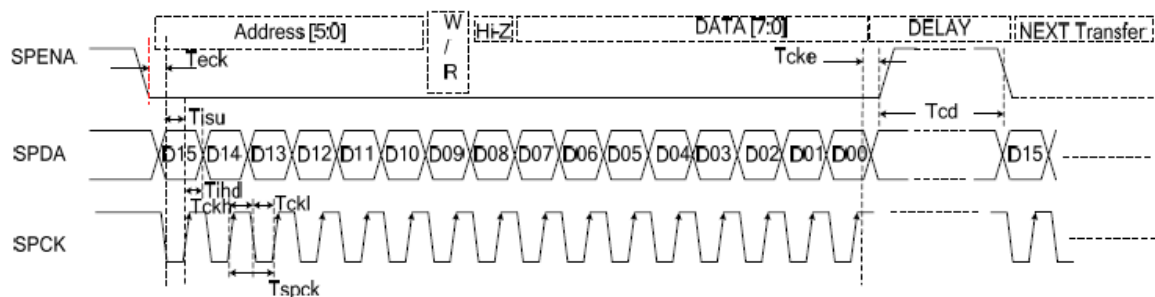

| Parameter               | Symbol | Min. | Typ. | Max. | Unit | Conditions |
|-------------------------|--------|------|------|------|------|------------|
| SPCK cycle time         | Tspck  | 320  | -    | -    | ns   |            |
| SPCK pulse duty         | Tscdut | 40   | 50   | 60   | %    |            |
| Serial data setup time  | Tisu   | 120  | -    | -    | ns   |            |
| Serial data hold time   | Tihd   | 120  | -    | -    | ns   |            |
| Serial clock high/low   | Tssw   | 120  | -    | -    | ns   |            |
| Chip select distinguish | Tcd    | 1    | -    | -    | us   |            |

### 5.7 3-Wire Control Registers List

| 3-Wire Register |      | Register Description |     |   |
|-----------------|------|----------------------|-----|---|
| D[15:10]        | Name | Init                 | R/W | Function Description                          |
| 000000b         | R00  | 07h                  | R/W | System control register                       |
| 000001b         | R01  | 00h                  | R/W | Timing Controller function register           |
| 000010b         | R02  | 03h                  | R/W | Operation control register                    |
| 000011b         | R03  | CCh                  | R/W | Input data Format control register            |
| 000100b         | R04  | 46h                  | R/W | Source Timing delay control register          |
| 000101b         | R05  | 0Dh                  | R/W | Gate Timing delay control register            |
| 000110b         | R06  | 00h                  | R/W | Reserved                                      |
| 000111b         | R07  | 00h                  | R/W | Internal function control register            |
| 001000b         | R08  | 08h                  | R/W | RGB Contrast control register                 |
| 001001b         | R09  | 40h                  | R/W | RGB Brightness control register               |
| 001010b         | R0A  | 88h                  | R/W | Hue / Saturation control register             |
| 001011b         | R0B  | 88h                  | R/W | R / B Sub-Contrast control register           |
| 001100b         | R0C  | 20h                  | R/W | R Sub-Brightness control register             |
| 001101b         | R0D  | 20h                  | R/W | B Sub-Brightness control register             |
| 001110b         | R0E  | 10h                  | R/W | VCOMDC Level control register                 |
| 001111b         | R0F  | A4h                  | R/W | VCOMAC Level control register                 |
| 010000b         | R10  | 04h                  | R/W | VGAM2 Level control register                  |
| 010001b         | R11  | 24h                  | R/W | VGAM3/4 Level control register                |
| 010010b         | R12  | 24h                  | R/W | VGAM5/6 Level control register                |
| 011110b         | R1E  | 00h                  | R/W | Reserved                                      |
| 100000b         | R20  | 00h                  | R/W | Wide and narrow display mode control register |

**Note 5-1:**

R03: c4h:ITU-R BT 656 Mode  
 c2h:ITU-R BT 601 Mode  
 c8h:8 bit RGB Mode(HV Mode)  
 c9h:8 bit RGB Mode(DE Mode)  
 cch(default):24 bit RGB Mode (HV mode)  
 cdh:24 bit RGB Mode (DE mode)

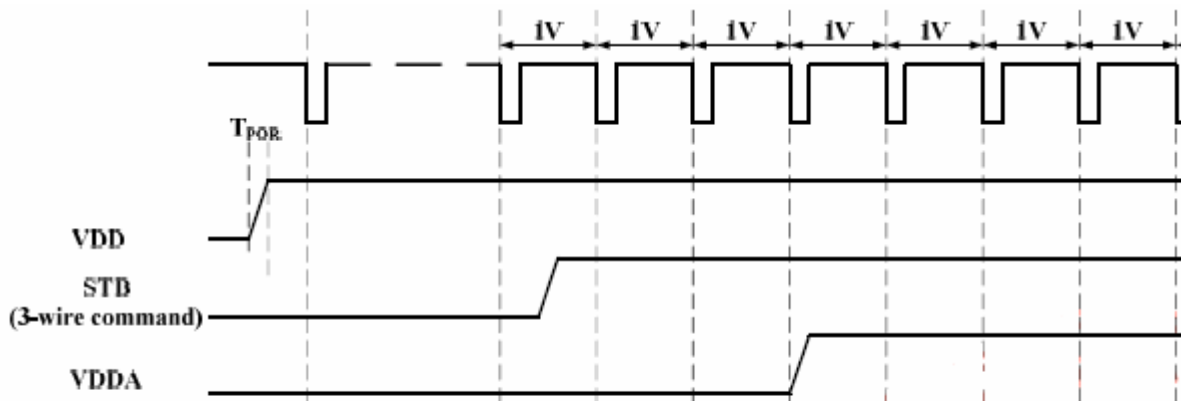
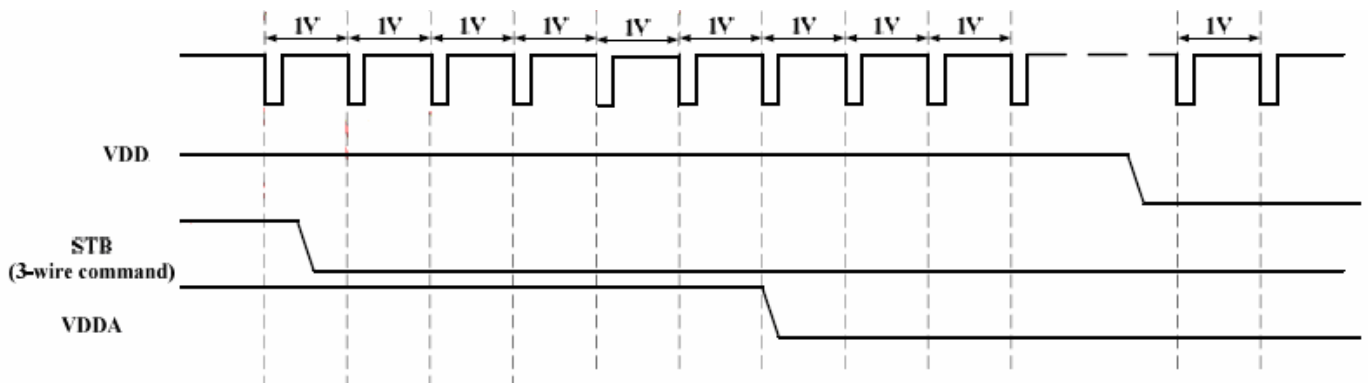
**5.8 Power on/off sequence**
**Power on sequence**

**Power off sequence**

## 6 OPTICAL CHARACTERISTICS

### 6.1 Optical Specification

Ta=25°C

| Item             | Symbol     | Condition          | Min   | Typ.  | Max.  | Unit              | Remark  |
|------------------|------------|--------------------|-------|-------|-------|-------------------|---------|
| View Angles      | $\theta T$ | $CR \geq 10$       | 30    | 40    |       | Degree            | Note 2  |
|                  | $\theta B$ |                    | 50    | 60    |       |                   |         |
|                  | $\theta L$ |                    | 50    | 60    |       |                   |         |
|                  | $\theta R$ |                    | 50    | 60    |       |                   |         |
| Contrast Ratio   | CR         | $\theta = 0^\circ$ |       | 350   |       |                   | Note1,3 |
| Response Time    | Ton        | 25°C               |       | 25    | 40    | ms                | Note1,4 |
|                  | Toff       |                    |       |       |       |                   |         |
| Chromaticity     | White      | x                  | 0.260 | 0.310 | 0.360 |                   | Note1,5 |
|                  |            | y                  | 0.283 | 0.333 | 0.383 |                   |         |
|                  | RED        | x                  | 0.574 | 0.624 | 0.674 |                   |         |
|                  |            | y                  | 0.318 | 0.368 | 0.418 |                   |         |
|                  | GREEN      | x                  | 0.300 | 0.350 | 0.400 |                   |         |
|                  |            | y                  | 0.500 | 0.550 | 0.600 |                   |         |
|                  | BLUE       | x                  | 0.093 | 0.143 | 0.193 |                   |         |
|                  |            | y                  | 0.069 | 0.119 | 0.169 |                   |         |
| Uniformity       | U          |                    | 75    | 80    |       | %                 | Note1,6 |
| NTSC             |            |                    |       | 50    |       | %                 | Note 5  |
| Luminance(w TSP) | L          |                    | 280   | 350   |       | cd/m <sup>2</sup> | Note1,7 |

Test Conditions:

1. VDD=3.3V,  $I_L = 20\text{mA}$ (Backlight current), the ambient temperature is 25°C.
2. The test systems refer to Note 1 and Note 2.



**Note 1:** Definition of optical measurement system.

The optical characteristics should be measured in dark room. After 5 minutes operation, the optical properties are measured at the center point of the LCD screen. All input terminals LCD panel must be ground when measuring the center area of the panel.

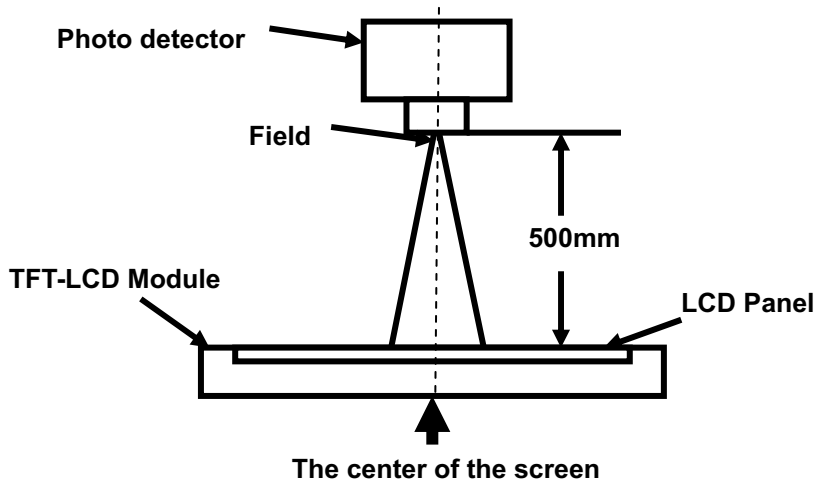

| Item           | Photo detector | Field |
|----------------|----------------|-------|
| Contrast Ratio | SR-3A          | 1°    |
| Luminance      |                |       |
| Chromaticity   |                |       |
| Lum Uniformity |                |       |
| Response Time  | BM-7A          | 2°    |

**Note 2:** Definition of viewing angle range and measurement system.

viewing angle is measured at the center point of the LCD by CONOSCOPE(ergo-80).

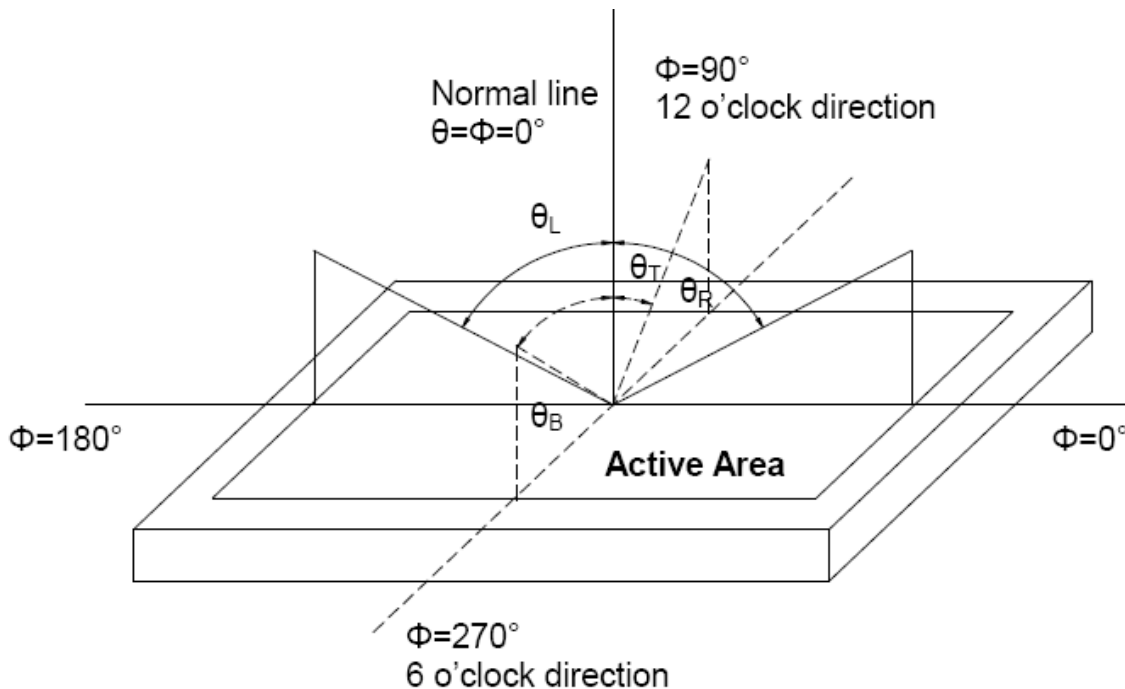

Fig. 1 Definition of viewing angle

**Note 3:** Definition of contrast ratio

$$\text{Contrast ratio (CR)} = \frac{\text{Luminance measured when LCD is on the "White" state}}{\text{Luminance measured when LCD is on the "Black" state}}$$

“White state “:The state is that the LCD is driven by  $V_{\text{white}}$ .

“Black state”: The state is that the LCD is driven by  $V_{\text{black}}$ .

$V_{\text{white}}$ : To be determined       $V_{\text{black}}$ : To be determined.

**Note 4:** Definition of Response time

The response time is defined as the LCD optical switching time interval between “White” state and “Black” state. Rise time ( $T_{\text{ON}}$ ) is the time between photo detector output intensity changed from 90% to 10%. And fall time ( $T_{\text{OFF}}$ ) is the time between photo detector output intensity changed from 10% to 90%.

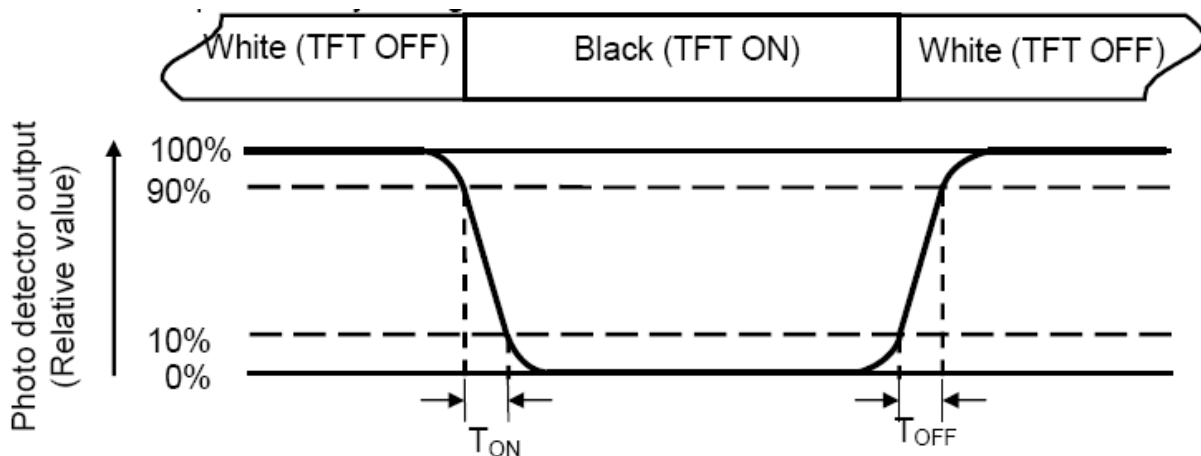

**Note 5:** Definition of color chromaticity (CIE1931)

Color coordinates measured at center point of LCD.

**Note 6:** Definition of Luminance Uniformity

Active area is divided into 9 measuring areas (Refer Fig. 2). Every measuring point is placed at the center of each measuring area.

$$\text{Luminance Uniformity}(U) = L_{\min} / L_{\max}$$

L-----Active area length W----- Active area width

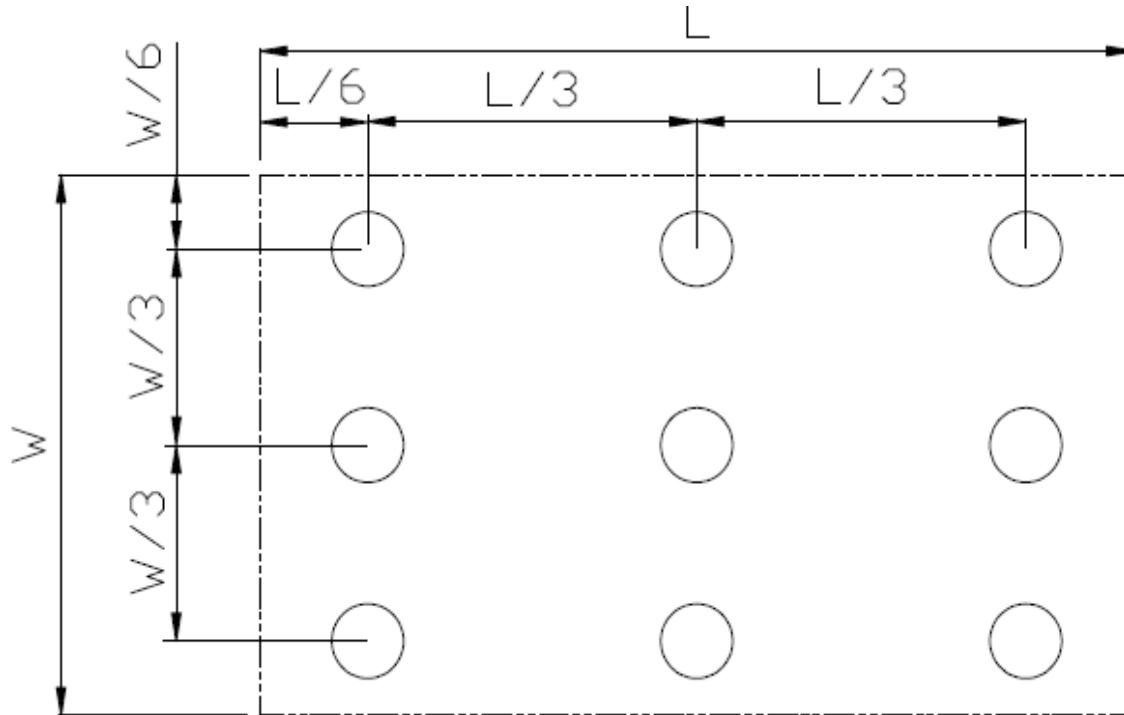

Fig. 2 Definition of uniformity

$L_{\max}$ : The measured maximum luminance of all measurement position.

$L_{\min}$ : The measured minimum luminance of all measurement position.

**Note 7:** Definition of Luminance :

Measure the luminance of white state at center point

**5 Environmental / Reliability Tests**

| No | Test Item  | Condition  | Remarks   |
|----|--|--|---|
| 1  | High Temperature Operation                         | Ts=+60°C, 240hrs   | Note1<br>IEC60068-2-2,GB2423.2—89   |
| 2  | Low Temperature Operation                          | Ta=-20°C, 240hrs   | Note 2, IEC60068-2-1<br>GB2423.1—89   |
| 3  | High Temperature Storage                           | Ta=+70°C, 240hrs   | IEC60068-2-2,<br>GB2423.2—89  |
| 4  | Low Temperature Storage                            | Ta=-30°C, 240hrs   | IEC60068-2-1<br>GB2423.1—89   |
| 5  | High Temperature & High Humidity ( Non-Operation ) | +60°C, 90% RH max,240 hours  | IEC60068-2-3,<br>GB/T2423.3—2006  |
| 6  | Thermal Shock (non-operation)                      | -30°C 30 min~+70°C 30 min,<br>Change time:5min, 30 Cycle   | Start with cold temperature, end<br>with high temperature<br>IEC60068-2-14,GB2423.22—87 |
| 7  | Electro Static Discharge (operation)               | C=150pF, R=330Ω, 5points/panel<br>Air:±8KV, 5times;Contact:±4KV, 5 times;<br>( Environment: 15°C ~35°C, 30%~60%,<br>86Kpa~106Kpa ) | IEC61000-4-2<br>GB/T17626.2—1998  |
| 8  | Vibration (non-operation)                          | Frequency range:10~55Hz, Stroke:1.5mm<br>Sweep:10Hz~55Hz~10Hz 2 hours for each<br>direction of X.Y.Z.(package condition)           | IEC60068-2-6<br>GB/T2423.10—1995  |
| 9  | Shock (non-operation)                              | 60G 6ms, ±X,±Y,±Z 3times for each di-<br>rection   | IEC60068-2-27<br>GB/T2423.5—1995  |
| 10 | Package Drop Test                                  | Height:80 cm, 1 corner, 3 edges, 6<br>surfaces   | IEC60068-2-32<br>GB/T2423.8—1995  |



8 MECHANICAL DRAWING

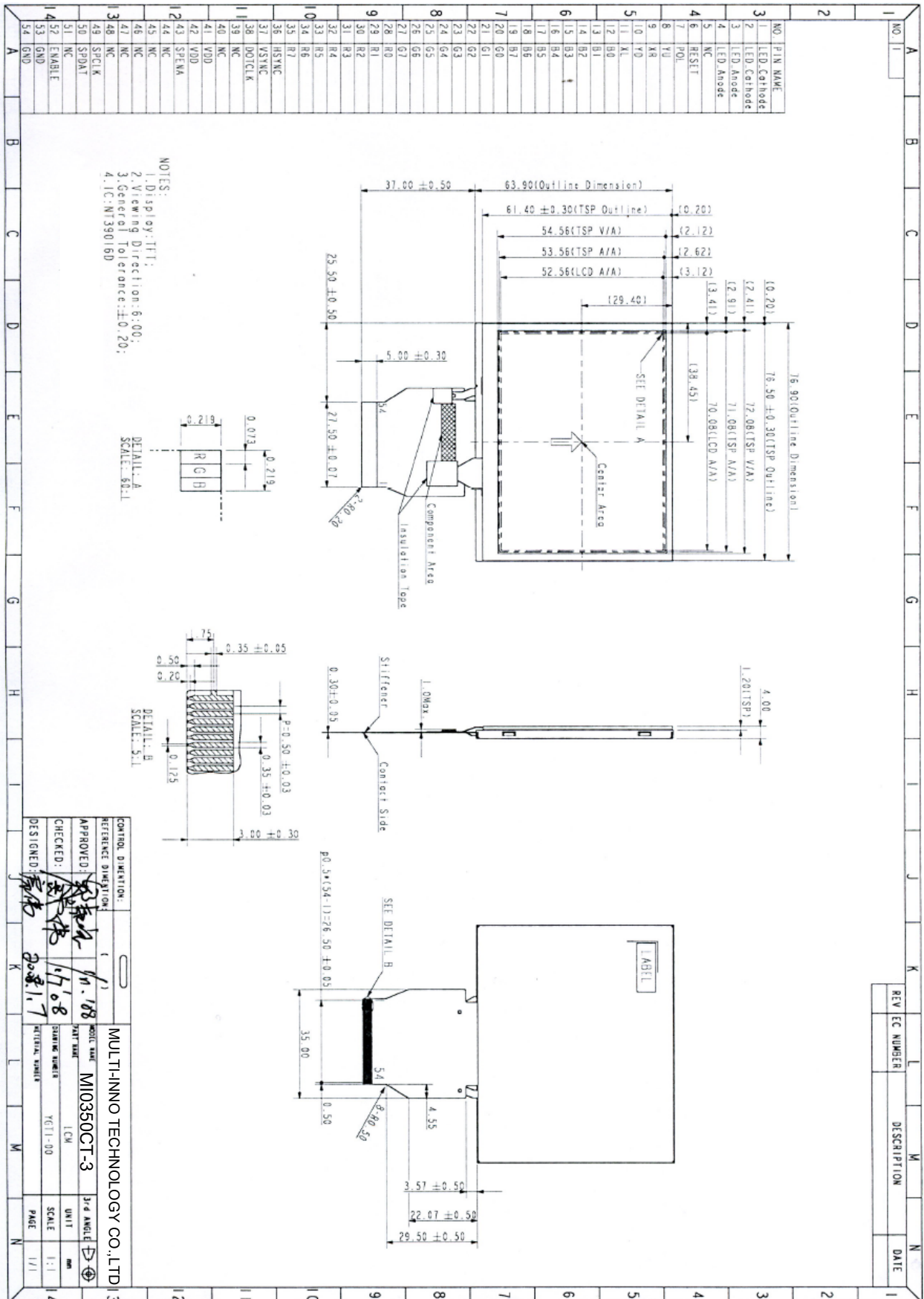



**9 Packing Drawing**

**TBD**



## 10. Precautions for Use of LCD Modules

### 10.1 Handling Precautions

**10.1.1.** The display panel is made of glass. Do not subject it to a mechanical shock by dropping it from a high place, etc.

**10.1.2.** If the display panel is damaged and the liquid crystal substance inside it leaks out, be sure not to get any in your mouth, if the substance comes into contact with your skin or clothes, promptly wash it off using soap and water.

**10.1.3.** Do not apply excessive force to the display surface or the adjoining areas since this may cause the color tone to vary.

**10.1.4.** The polarizer covering the display surface of the LCD module is soft and easily scratched. Handle this polarizer carefully.

**10.1.5.** If the display surface is contaminated, breathe on the surface and gently wipe it with a soft dry cloth. If still not completely clear, moisten cloth with one of the following solvents:

- Isopropyl alcohol
- Ethyl alcohol

Solvents other than those mentioned above may damage the polarizer. Especially, do not use the following:

- Water
- Ketone
- Aromatic solvents

**10.1.6.** Do not attempt to disassemble the LCD Module.

**10.1.7.** If the logic circuit power is off, do not apply the input signals.

**10.1.8.** To prevent destruction of the elements by static electricity, be careful to maintain an optimum work environment.

- a. Be sure to ground the body when handling the LCD Modules.
- b. Tools required for assembly, such as soldering irons, must be properly ground.
- c. To reduce the amount of static electricity generated, do not conduct assembly and other work under dry conditions.
- d. The LCD Module is coated with a film to protect the display surface. Be care when peeling off this protective film since static electricity may be generated.

### 10.2 Storage precautions

**10.2.1.** When storing the LCD modules, avoid exposure to direct sunlight or to the light of fluorescent lamps.

**10.2.2.** The LCD modules should be stored under the storage temperature range. If the LCD modules will be stored for a long time, the recommend condition is:

Temperature : 0°C ~ 40°C      Relatively humidity: ≤80%

**10.2.3.** The LCD modules should be stored in the room without acid, alkali and harmful gas.



### **10.3 Transportation Precautions**

The LCD modules should be no falling and violent shocking during transportation, and also should avoid excessive press, water, damp and sunshine.