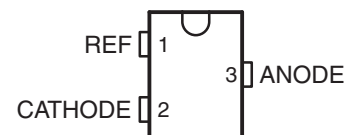

ADJUSTABLE PRECISION SHUNT REGULATORS

 Check for Samples: [TL432A-Q1](#), [TL432B-Q1](#)

FEATURES

- Qualified for Automotive Applications
- AEC-Q100 Qualified With the Following Results:
 - Device Temperature Grade 1: –40°C to 125°C Ambient Operating Temperature Range
 - Device HBM ESD Classification Level H2
 - Device CDM ESD Classification Level C3B
- Operation From –40°C to 125°C
- Reference Voltage Tolerance at 25°C
 - 0.5%...B Grade
 - 1%...A Grade
- Typical Temperature Drift...14 mV
- Low Output Noise
- Typical Output Impedance...0.2 Ω
- Sink Current Capability...1 mA to 100 mA
- Adjustable Output Voltage... V_{ref} to 36 V

 DBZ (SOT-23-3) PACKAGE
(TOP VIEW)

DESCRIPTION/ORDERING INFORMATION

The TL432x-Q1 devices are three-terminal adjustable shunt regulators with specified thermal stability over the automotive temperature range. The output voltage can be set to any value between V_{ref} (approximately 2.5 V) and 36 V with two external resistors (see [Figure 17](#)). These devices have a typical output impedance of 0.2 Ω. Active output circuitry provides a very sharp turn-on characteristic, making these devices excellent replacements for Zener diodes in many applications such as onboard regulation, adjustable power supplies, and switching power supplies.

The TL432x-Q1 devices are offered in two grades with initial tolerances (at 25°C) of 0.5% and 1%, for the B and A grade, respectively. In addition, low output drift vs temperature ensures good stability over the entire temperature range.

The devices are characterized for operation from –40°C to 125°C.

ORDERING INFORMATION⁽¹⁾

T_A	V_{ref} TOLERANCE ($T_A = 25^\circ\text{C}$)	PACKAGE ⁽²⁾		ORDERABLE PART NUMBER	TOP-SIDE MARKING
		SOT23 – DBZ	Reel of 3000		
–40°C to 125°C	A Grade: 1%	SOT23 – DBZ	Reel of 3000	TL432AQDBZRQ1	TOIQ
	B Grade: 0.5 %			TL432BQDBZRQ1	TOHQ

(1) For the most current package and ordering information, see the Package Option Addendum at the end of this document, or see the TI web site at www.ti.com.

(2) Package drawings, thermal data, and symbolization are available at www.ti.com/packaging.



Please be aware that an important notice concerning availability, standard warranty, and use in critical applications of Texas Instruments semiconductor products and disclaimers thereto appears at the end of this data sheet.

SYMBOL

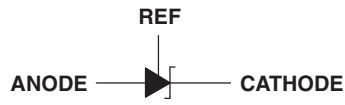

FUNCTIONAL BLOCK DIAGRAM

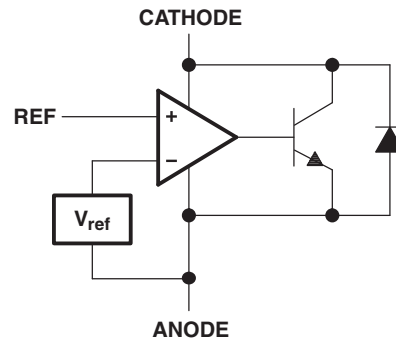

EQUIVALENT SCHEMATIC

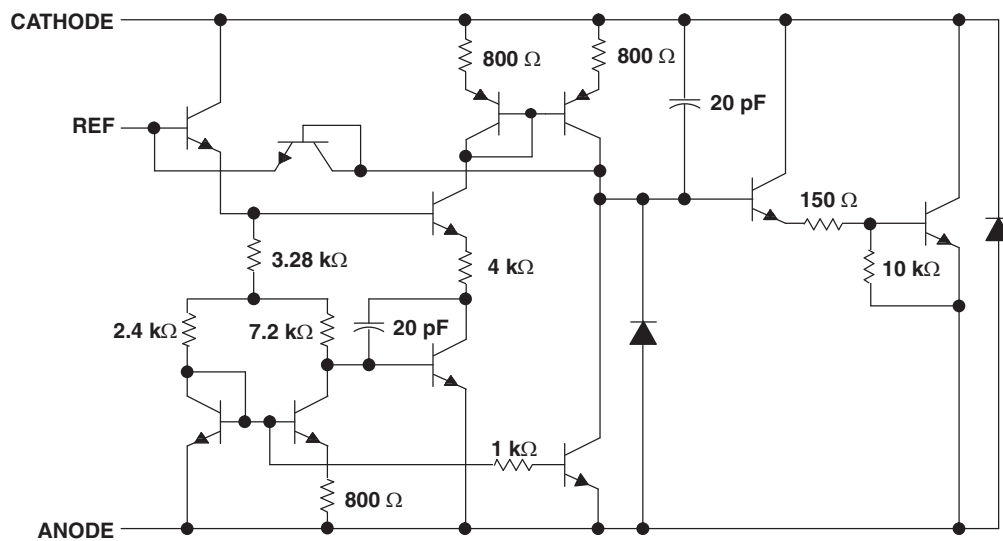

NOTE: All component values are nominal.

ABSOLUTE MAXIMUM RATINGS⁽¹⁾

over operating free-air temperature range (unless otherwise noted)

V_{KA}	Cathode voltage ⁽²⁾	37 V
I_{KA}	Continuous cathode current range	–100 mA to 150 mA
	Reference input current range	–50 μ A to 10 mA
T_J	Operating virtual-junction temperature	150°C
T_{stg}	Storage temperature range	–65°C to 150°C

- (1) Stresses beyond those listed under *absolute maximum ratings* may cause permanent damage to the device. These are stress ratings only, and functional operation of the device at these or any other conditions beyond those indicated under *recommended operating conditions* is not implied. Exposure to absolute-maximum-rated conditions for extended periods may affect device reliability.
- (2) Voltage values are with respect to the ANODE terminal, unless otherwise noted.

PACKAGE THERMAL DATA

PACKAGE	BOARD	θ_{JC}	θ_{JA}
SOT-23-3 (DBZ)	High K, JESD 51-7	76°C/W	206°C/W

RECOMMENDED OPERATING CONDITIONS

		MIN	MAX	UNIT
V_{KA}	Cathode voltage	V_{ref}	36	V
I_{KA}	Cathode current	1	100	mA
T_A	Operating free-air temperature	–40	125	°C
ESD Ratings	Human-body model (HBM) AEC-Q100 classification level H2		2	kV
	Charged-device model (CDM) AEC-Q100 classification level C3B		750	V

TL432A-Q1 ELECTRICAL CHARACTERISTICS

over recommended operating conditions, $T_A = 25^\circ\text{C}$ (unless otherwise noted)

PARAMETER	TEST CIRCUIT	TEST CONDITIONS	MIN	TYP	MAX	UNIT
V_{ref} Reference voltage	Figure 2	$V_{\text{KA}} = V_{\text{ref}}, I_{\text{KA}} = 10 \text{ mA}$	2470	2495	2520	mV
$V_{\text{I(dev)}}$ Deviation of reference voltage over full temperature range (see Figure 1)	Figure 2	$V_{\text{KA}} = V_{\text{ref}}, I_{\text{KA}} = 10 \text{ mA}, T_A = -40^\circ\text{C to } 125^\circ\text{C}$		14	34	mV
$\frac{\Delta V_{\text{ref}}}{\Delta V_{\text{KA}}}$ Ratio of change in reference voltage to the change in cathode voltage	Figure 3	$I_{\text{KA}} = 10 \text{ mA}$	$\Delta V_{\text{KA}} = 10 \text{ V} - V_{\text{ref}}$	-1.4	-2.7	mV/V
			$\Delta V_{\text{KA}} = 36 \text{ V} - 10 \text{ V}$	-1	-2	
I_{ref} Reference current	Figure 3	$I_{\text{KA}} = 10 \text{ mA}, R1 = 10 \text{ k}\Omega, R2 = \infty$		2	4	μA
$I_{\text{I(dev)}}$ Deviation of reference current over full temperature range (see Figure 1)	Figure 3	$I_{\text{KA}} = 10 \text{ mA}, R1 = 10 \text{ k}\Omega, R2 = \infty, T_A = -40^\circ\text{C to } 125^\circ\text{C}$		0.8	2.5	μA
I_{min} Minimum cathode current for regulation	Figure 2	$V_{\text{KA}} = V_{\text{ref}}$		0.4	0.7	mA
I_{off} Off-state cathode current	Figure 4	$V_{\text{KA}} = 36 \text{ V}, V_{\text{ref}} = 0$		0.1	0.5	μA
$ z_{\text{KA}} $ Dynamic impedance (see Figure 1)	Figure 2	$I_{\text{KA}} = 1 \text{ mA to } 100 \text{ mA}, V_{\text{KA}} = V_{\text{ref}}, f \leq 1 \text{ kHz}$		0.2	0.5	Ω

TL432B-Q1 ELECTRICAL CHARACTERISTICS

over recommended operating conditions, $T_A = 25^\circ\text{C}$ (unless otherwise noted)

PARAMETER	TEST CIRCUIT	TEST CONDITIONS	MIN	TYP	MAX	UNIT
V_{ref} Reference voltage	Figure 2	$V_{\text{KA}} = V_{\text{ref}}, I_{\text{KA}} = 10 \text{ mA}$	2483	2495	2507	mV
$V_{\text{I(dev)}}$ Deviation of reference voltage over full temperature range (see Figure 1)	Figure 2	$V_{\text{KA}} = V_{\text{ref}}, I_{\text{KA}} = 10 \text{ mA}, T_A = -40^\circ\text{C to } 125^\circ\text{C}$		14	34	mV
$\frac{\Delta V_{\text{ref}}}{\Delta V_{\text{KA}}}$ Ratio of change in reference voltage to the change in cathode voltage	Figure 3	$I_{\text{KA}} = 10 \text{ mA}$	$\Delta V_{\text{KA}} = 10 \text{ V} - V_{\text{ref}}$	-1.4	-2.7	mV/V
			$\Delta V_{\text{KA}} = 36 \text{ V} - 10 \text{ V}$	-1	-2	
I_{ref} Reference current	Figure 3	$I_{\text{KA}} = 10 \text{ mA}, R1 = 10 \text{ k}\Omega, R2 = \infty$		2	4	μA
$I_{\text{I(dev)}}$ Deviation of reference current over full temperature range (see Figure 1)	Figure 3	$I_{\text{KA}} = 10 \text{ mA}, R1 = 10 \text{ k}\Omega, R2 = \infty, T_A = -40^\circ\text{C to } 125^\circ\text{C}$		0.8	2.5	μA
I_{min} Minimum cathode current for regulation	Figure 2	$V_{\text{KA}} = V_{\text{ref}}$		0.4	0.7	mA
I_{off} Off-state cathode current	Figure 4	$V_{\text{KA}} = 36 \text{ V}, V_{\text{ref}} = 0$		0.1	0.5	μA
$ z_{\text{KA}} $ Dynamic impedance (see Figure 1)	Figure 2	$I_{\text{KA}} = 1 \text{ mA to } 100 \text{ mA}, V_{\text{KA}} = V_{\text{ref}}, f \leq 1 \text{ kHz}$		0.2	0.5	Ω

Deviation Parameters

The deviation parameters $V_{ref(dev)}$ and $I_{ref(dev)}$ are defined as the differences between the maximum and minimum values obtained over the recommended temperature range. The average full-range temperature coefficient of the reference voltage, $\alpha_{V_{ref}}$, is defined as:

$$|\alpha_{V_{ref}}| \left(\frac{\text{ppm}}{^{\circ}\text{C}} \right) = \frac{\left(\frac{V_{I(dev)}}{V_{ref \text{ at } 25^{\circ}\text{C}}} \right) \times 10^6}{\Delta T_A}$$

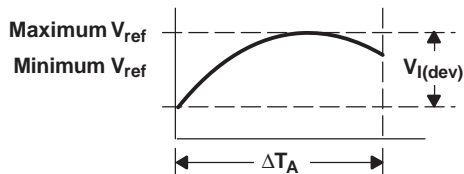

where:

ΔT_A is the recommended operating free-air temperature range of the device.

$\alpha_{V_{ref}}$ can be positive or negative, depending on whether minimum V_{ref} or maximum V_{ref} , respectively, occurs at the lower temperature.

Example: $V_{ref} = 2495 \text{ mV}$ at 25°C , $V_{I(dev)} = 14 \text{ mV}$, $\Delta T_A = 165^{\circ}\text{C}$ for TL432B

$$|\alpha_{V_{ref}}| = \frac{\left(\frac{14 \text{ mV}}{2495 \text{ mV}} \right) \times 10^6}{165^{\circ}\text{C}} \approx 34 \frac{\text{ppm}}{^{\circ}\text{C}}$$

Because minimum V_{ref} occurs at the lower temperature, the coefficient is positive.

Dynamic Impedance

The dynamic impedance is defined as: $|z_{KA}| = \frac{\Delta V_{KA}}{\Delta I_{KA}}$

When the device is operating with two external resistors (see Figure 3), the total dynamic impedance of the circuit is given by:

$$|z'| = \frac{\Delta V}{\Delta I} \approx |z_{KA}| \left(1 + \frac{R1}{R2} \right)$$

Figure 1. Calculating Deviation Parameters and Dynamic Impedance

PARAMETER MEASUREMENT INFORMATION

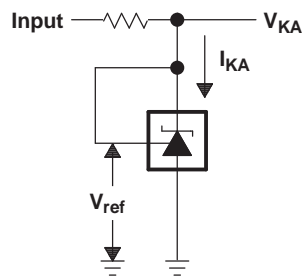

Figure 2. Test Circuit for $V_{KA} = V_{ref}$

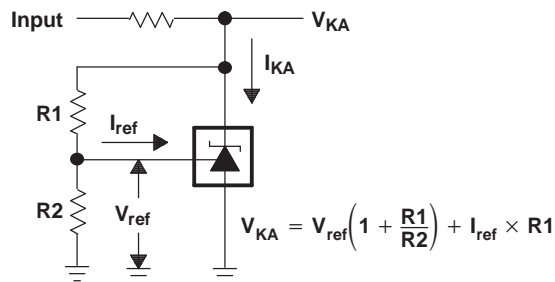

Figure 3. Test Circuit for $V_{KA} > V_{ref}$

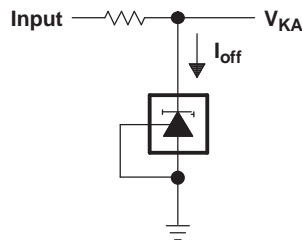

Figure 4. Test Circuit for I_{off}

TYPICAL CHARACTERISTICS

Data at high and low temperatures is applicable only within the recommended operating free-air temperature ranges of the various devices.

Table 1. Graphs

	FIGURE
Reference voltage vs Free-air temperature	Figure 5
Reference current vs Free-air temperature	Figure 6
Cathode current vs Cathode voltage	Figure 7, Figure 8
Off-state cathode current vs Free-air temperature	Figure 9
Ratio of delta reference voltage to delta cathode voltage vs Free-air temperature	Figure 10
Equivalent input noise voltage vs Frequency	Figure 11
Equivalent input noise voltage over a 10-s period	Figure 12
Small-signal voltage amplification vs Frequency	Figure 13
Reference impedance vs Frequency	Figure 14
Pulse response	Figure 15
Stability boundary conditions	Figure 16

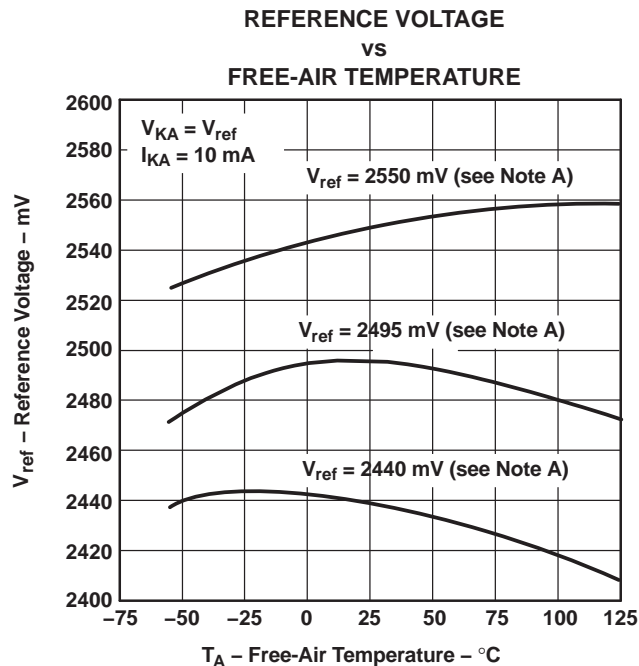

A. Data is for devices having the indicated value of V_{ref} at $I_{KA} = 10 \text{ mA}$, $T_A = 25^\circ\text{C}$.

Figure 5.

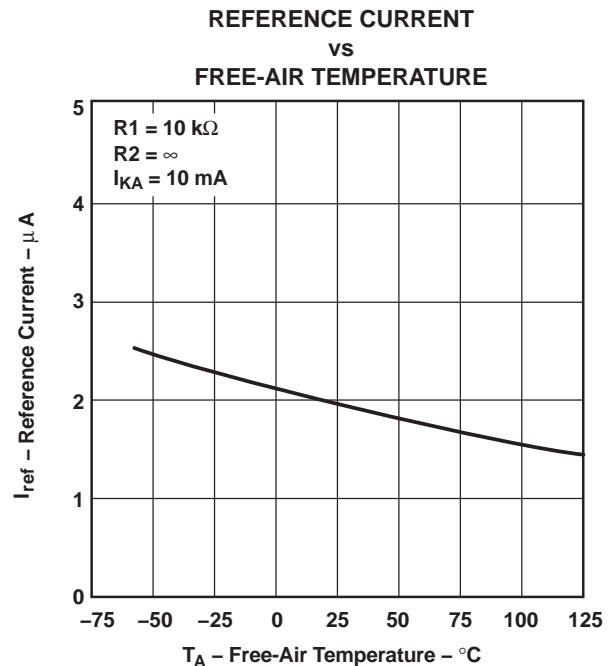

Figure 6.

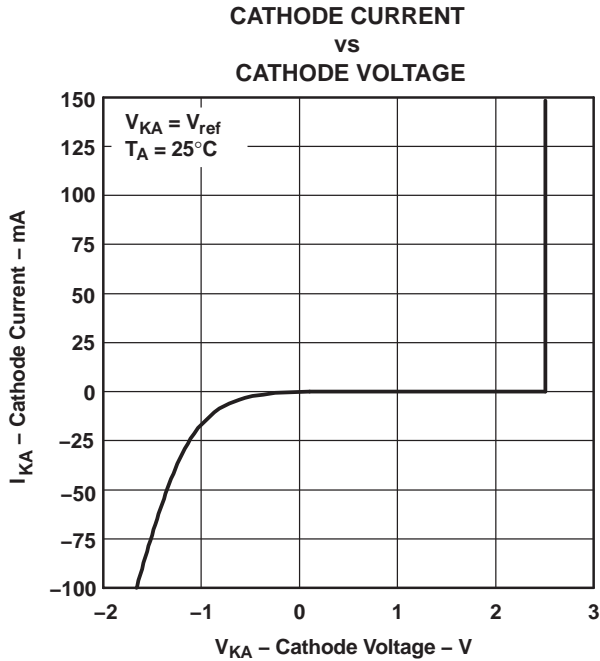

Figure 7.

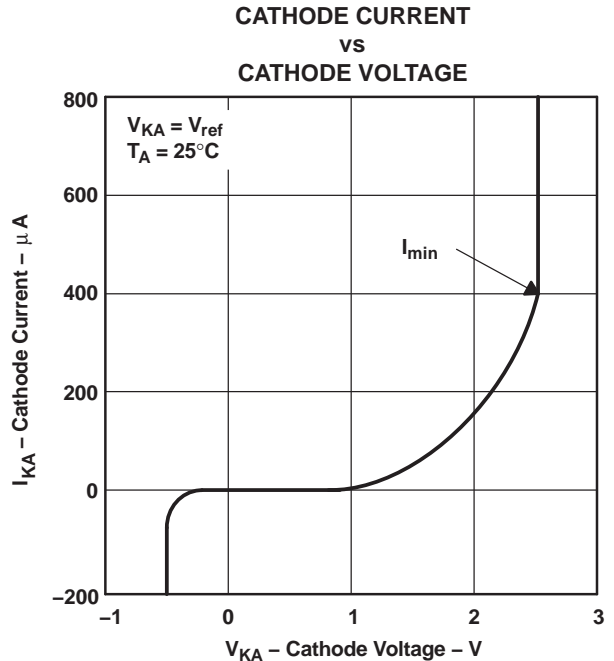

Figure 8.

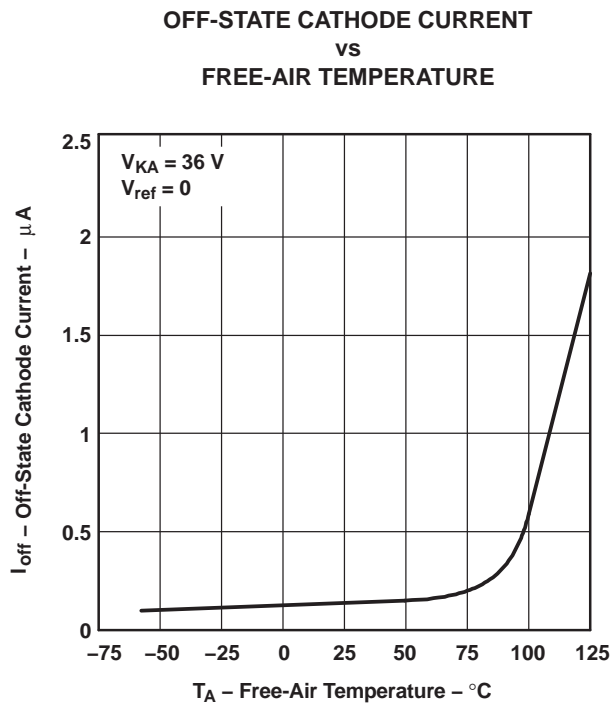

Figure 9.

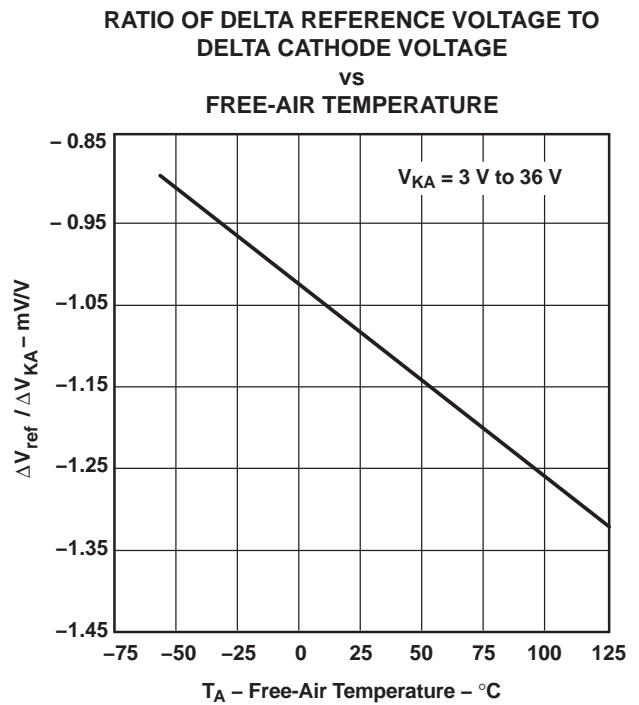

Figure 10.

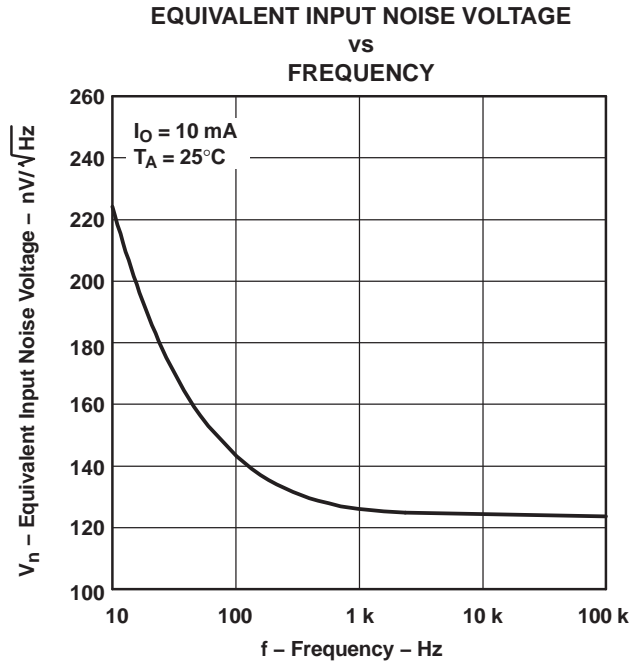

Figure 11.

EQUIVALENT INPUT NOISE VOLTAGE
OVER A 10-S PERIOD

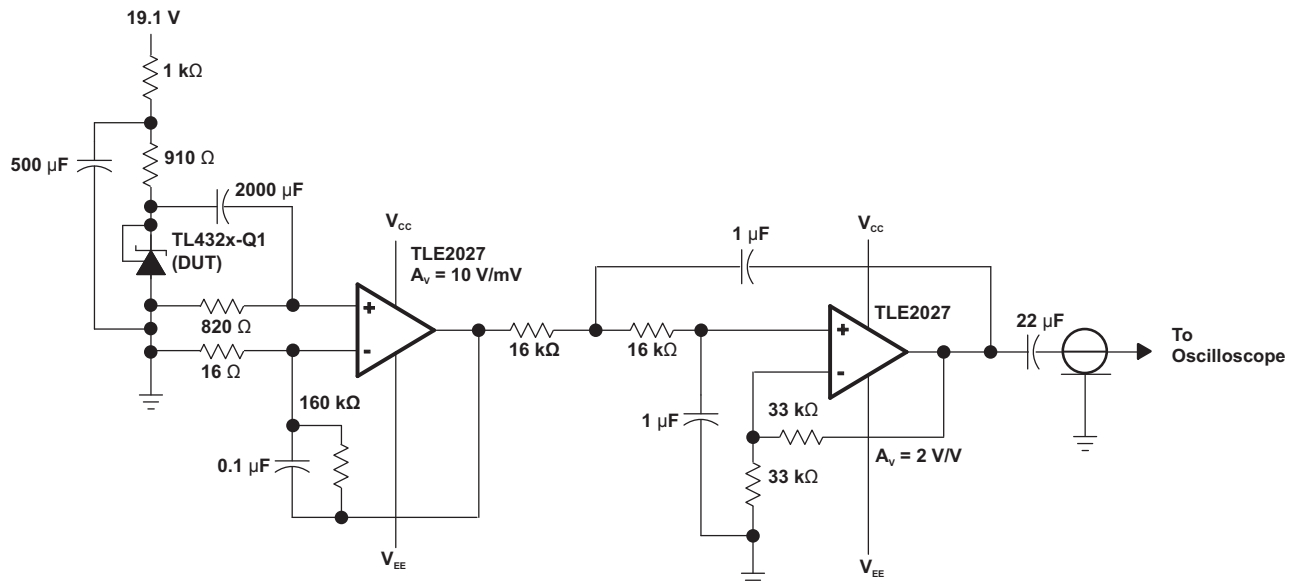
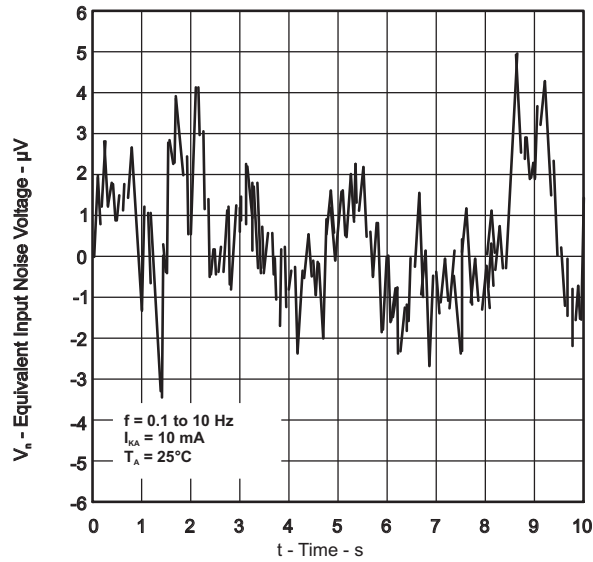

Figure 12. Test Circuit for Equivalent Input Noise Voltage

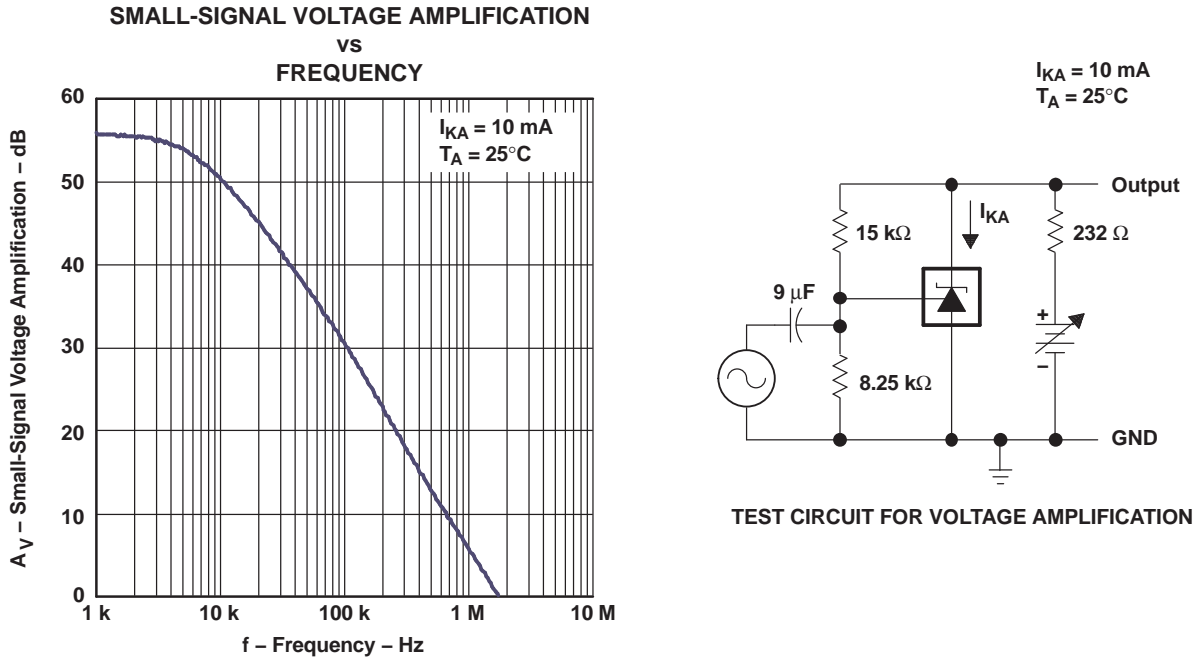

Figure 13.

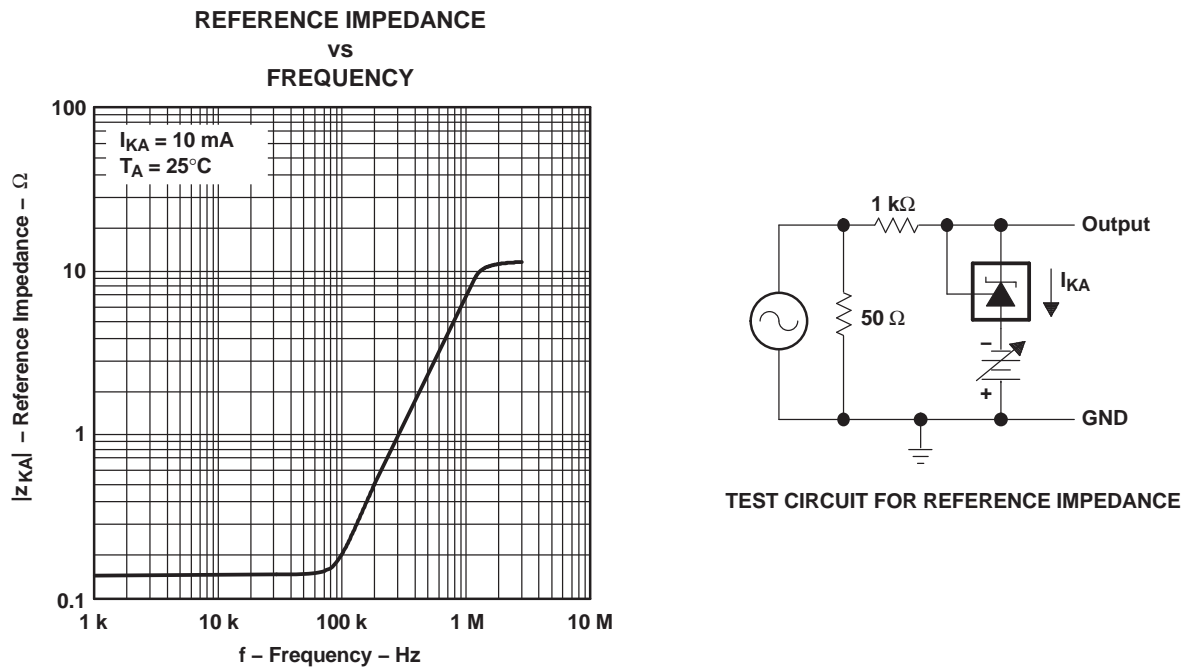

Figure 14.

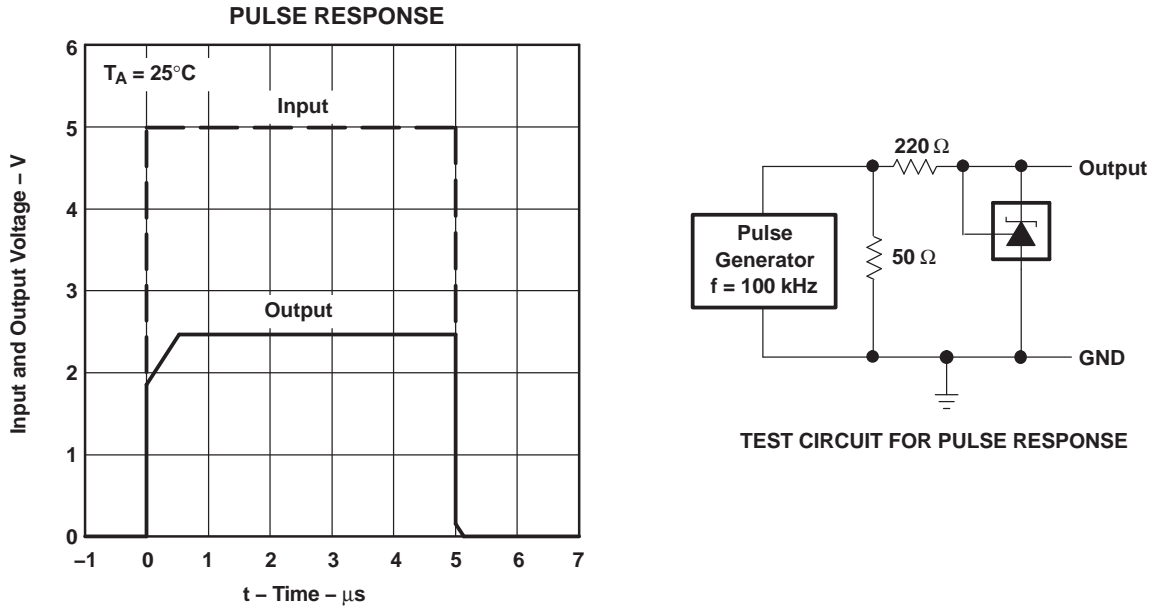

Figure 15.

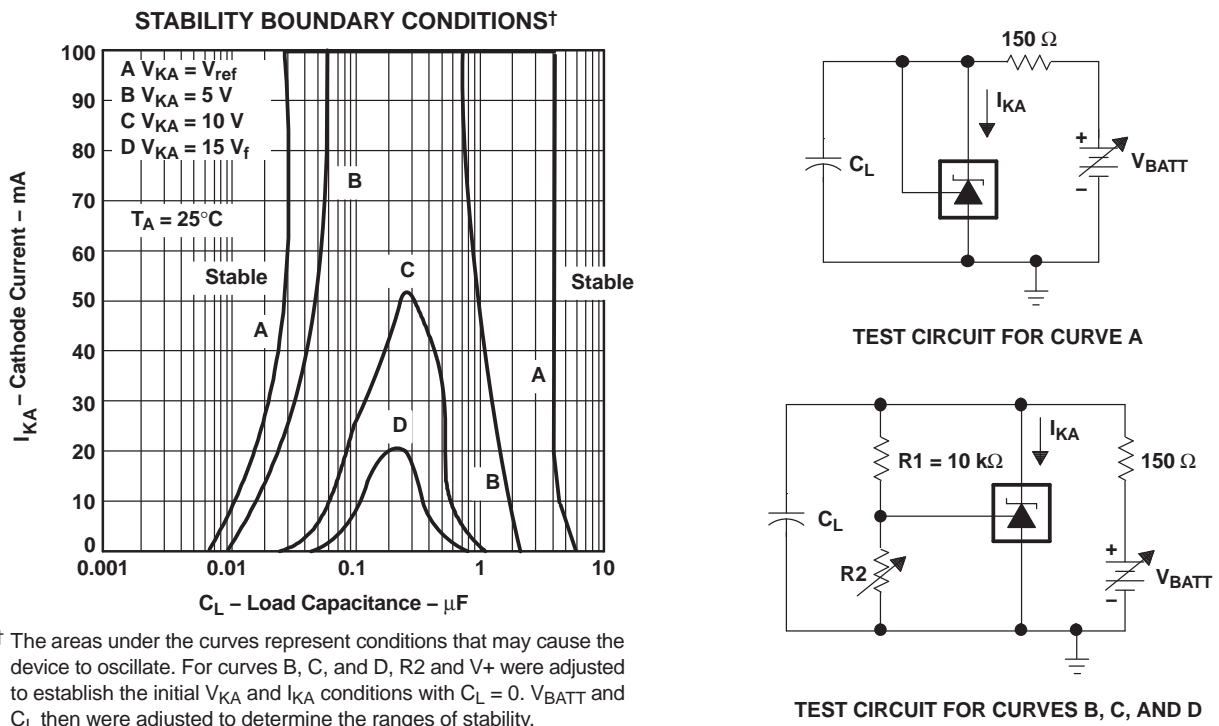
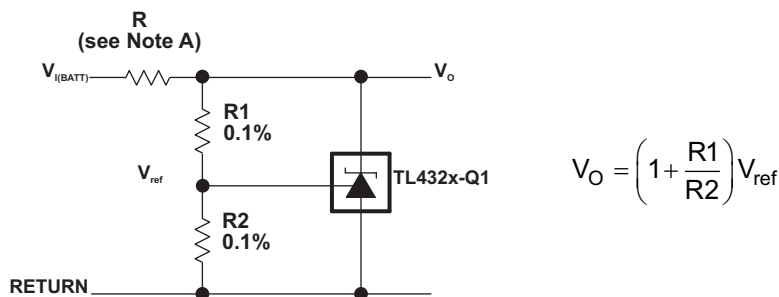

Figure 16.

APPLICATION INFORMATION

Table 2. Application Circuits

	FIGURE
Shunt regulator	Figure 17
Single-supply comparator with temperature-compensated threshold	Figure 18
Precision high-current series regulator	Figure 19
Output control of a three-terminal fixed regulator	Figure 20
High-current shunt regulator	Figure 21
Crowbar circuit	Figure 22
Precision 5-V 1.5-A regulator	Figure 23
Efficient 5-V precision regulator	Figure 24
PWM converter with reference	Figure 25
Voltage monitor	Figure 26
Delay timer	Figure 27
Precision current limiter	Figure 28
Precision constant-current sink	Figure 29



A. R should provide cathode current ≥ 1 mA to the TL432x-Q1 at minimum $V_{I(BATT)}$.

Figure 17. Shunt Regulator

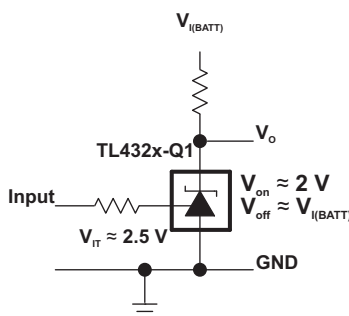
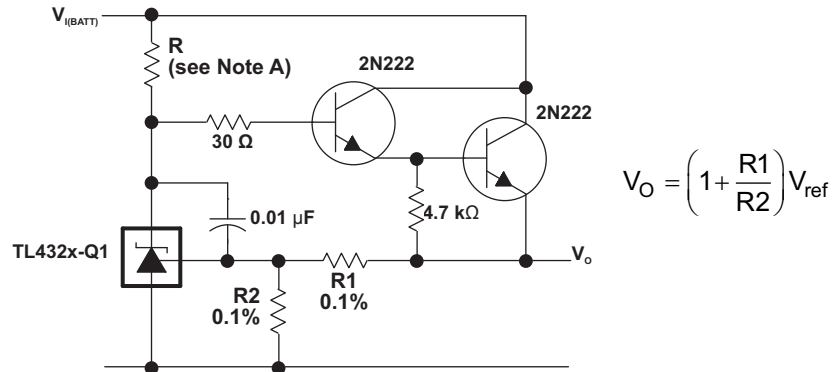

Figure 18. Single-Supply Comparator With Temperature-Compensated Threshold



A. R should provide cathode current ≥ 1 mA to the TL432x-Q1 at minimum $V_{I(BATT)}$.

Figure 19. Precision High-Current Series Regulator

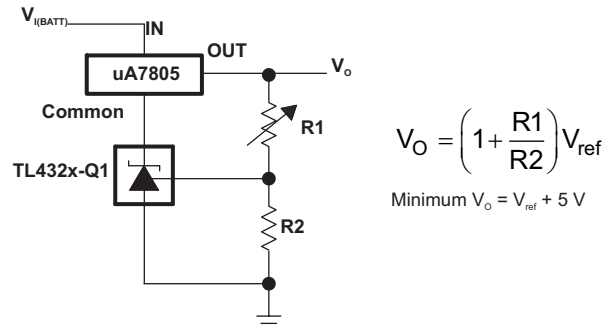

Figure 20. Output Control of a Three-Terminal Fixed Regulator

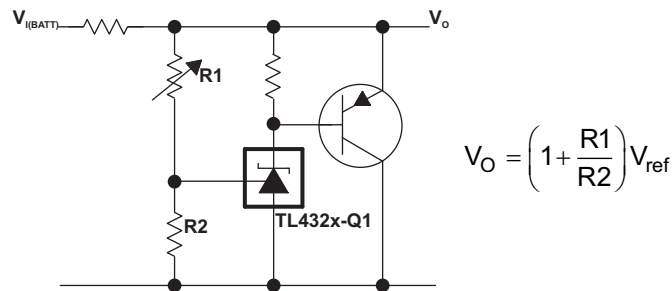
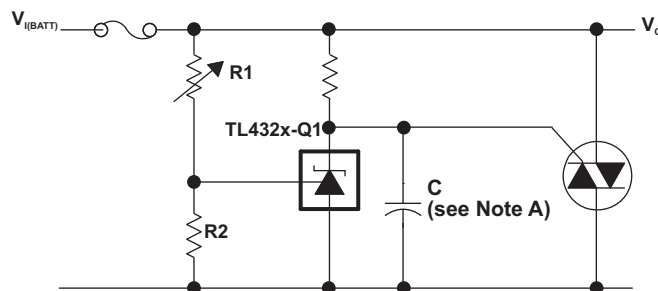

Figure 21. High-Current Shunt Regulator



A. See the stability boundary conditions in [Figure 16](#) to determine allowable values for C.

Figure 22. Crowbar Circuit

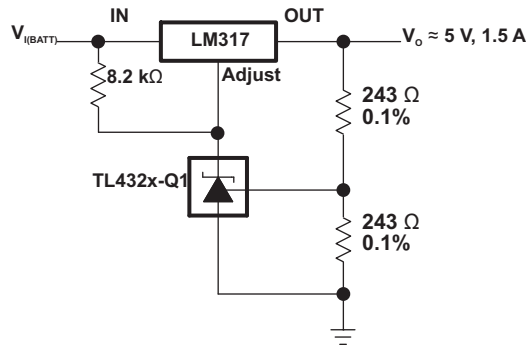
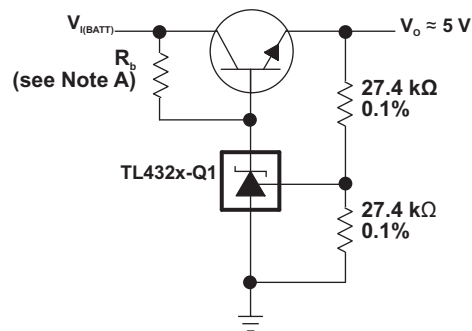

Figure 23. Precision 5-V 1.5-A Regulator



A. R_b should provide cathode current ≥ 1 mA to the TL432x-Q1.

Figure 24. Efficient 5-V Precision Regulator

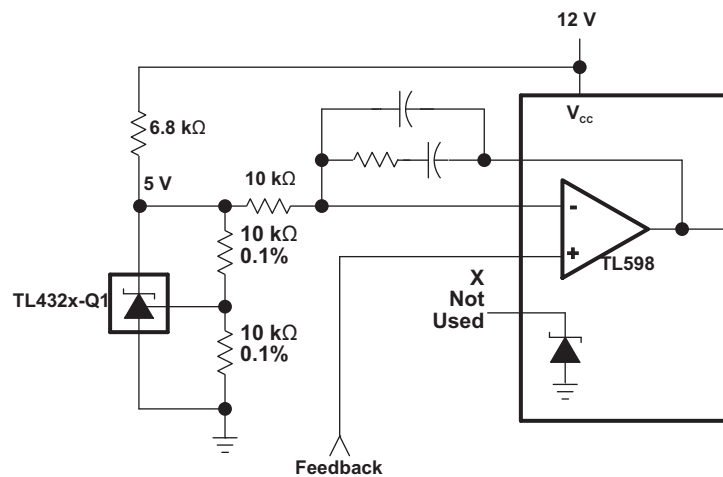
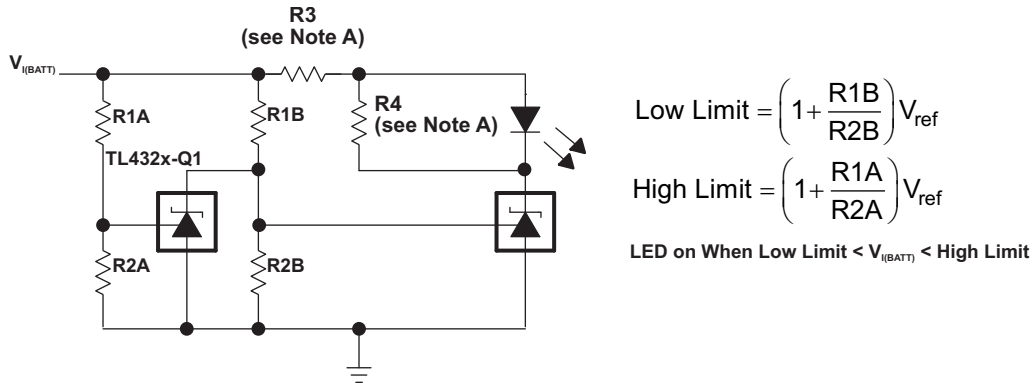

Figure 25. PWM Converter With Reference



- A. R3 and R4 are selected to provide the desired LED intensity and cathode current ≥ 1 mA to the TL432x-Q1 at the available $V_{I(BATT)}$.

Figure 26. Voltage Monitor

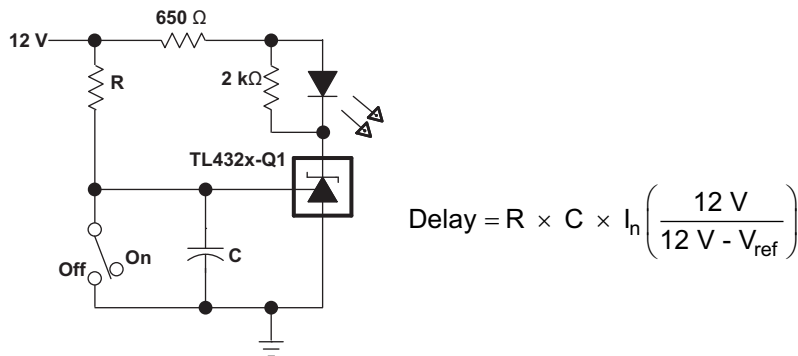

Figure 27. Delay Timer

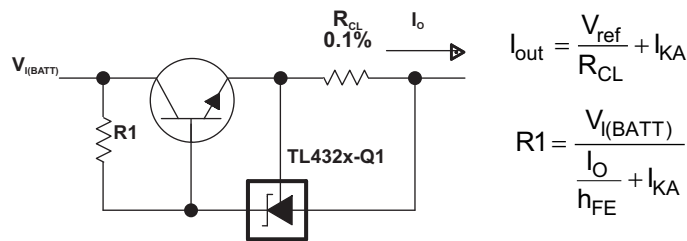

Figure 28. Precision Current Limiter

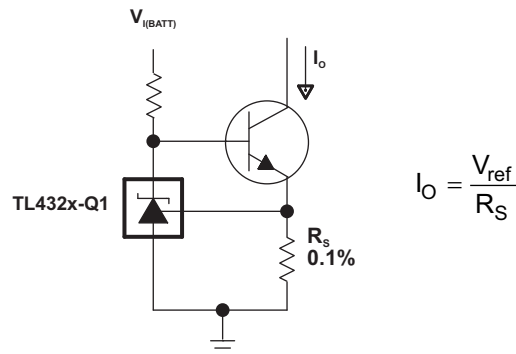

Figure 29. Precision Constant-Current Sink

REVISION HISTORY

Changes from Original (November, 2008) to Revision A	Page
• Added AEC-Q100 info to features	1
• Added ESD ratings information to recommended operating conditions table	3

PACKAGING INFORMATION

Orderable Device	Status (1)	Package Type	Package Drawing	Pins	Package Qty	Eco Plan (2)	Lead/Ball Finish	MSL Peak Temp (3)	Op Temp (°C)	Top-Side Markings (4)	Samples
TL432AQDBZRQ1	ACTIVE	SOT-23	DBZ	3	3000	Green (RoHS & no Sb/Br)	CU NIPDAU	Level-1-260C-UNLIM	-40 to 125	TOIQ	Samples
TL432BQDBZRQ1	ACTIVE	SOT-23	DBZ	3	3000	Green (RoHS & no Sb/Br)	CU NIPDAU	Level-1-260C-UNLIM	-40 to 125	TOHQ	Samples

(1) The marketing status values are defined as follows:

ACTIVE: Product device recommended for new designs.

LIFEBUY: TI has announced that the device will be discontinued, and a lifetime-buy period is in effect.

NRND: Not recommended for new designs. Device is in production to support existing customers, but TI does not recommend using this part in a new design.

PREVIEW: Device has been announced but is not in production. Samples may or may not be available.

OBSOLETE: TI has discontinued the production of the device.

(2) Eco Plan - The planned eco-friendly classification: Pb-Free (RoHS), Pb-Free (RoHS Exempt), or Green (RoHS & no Sb/Br) - please check <http://www.ti.com/productcontent> for the latest availability information and additional product content details.

TBD: The Pb-Free/Green conversion plan has not been defined.

Pb-Free (RoHS): TI's terms "Lead-Free" or "Pb-Free" mean semiconductor products that are compatible with the current RoHS requirements for all 6 substances, including the requirement that lead not exceed 0.1% by weight in homogeneous materials. Where designed to be soldered at high temperatures, TI Pb-Free products are suitable for use in specified lead-free processes.

Pb-Free (RoHS Exempt): This component has a RoHS exemption for either 1) lead-based flip-chip solder bumps used between the die and package, or 2) lead-based die adhesive used between the die and leadframe. The component is otherwise considered Pb-Free (RoHS compatible) as defined above.

Green (RoHS & no Sb/Br): TI defines "Green" to mean Pb-Free (RoHS compatible), and free of Bromine (Br) and Antimony (Sb) based flame retardants (Br or Sb do not exceed 0.1% by weight in homogeneous material)

(3) MSL, Peak Temp. -- The Moisture Sensitivity Level rating according to the JEDEC industry standard classifications, and peak solder temperature.

(4) Multiple Top-Side Markings will be inside parentheses. Only one Top-Side Marking contained in parentheses and separated by a "~" will appear on a device. If a line is indented then it is a continuation of the previous line and the two combined represent the entire Top-Side Marking for that device.

Important Information and Disclaimer: The information provided on this page represents TI's knowledge and belief as of the date that it is provided. TI bases its knowledge and belief on information provided by third parties, and makes no representation or warranty as to the accuracy of such information. Efforts are underway to better integrate information from third parties. TI has taken and continues to take reasonable steps to provide representative and accurate information but may not have conducted destructive testing or chemical analysis on incoming materials and chemicals. TI and TI suppliers consider certain information to be proprietary, and thus CAS numbers and other limited information may not be available for release.

In no event shall TI's liability arising out of such information exceed the total purchase price of the TI part(s) at issue in this document sold by TI to Customer on an annual basis.

OTHER QUALIFIED VERSIONS OF TL432A-Q1, TL432B-Q1 :

- Catalog: [TL432A](#), [TL432B](#)

NOTE: Qualified Version Definitions:

- Catalog - TI's standard catalog product

TAPE AND REEL INFORMATION



QUADRANT ASSIGNMENTS FOR PIN 1 ORIENTATION IN TAPE



*All dimensions are nominal

Device	Package Type	Package Drawing	Pins	SPQ	Reel Diameter (mm)	Reel Width W1 (mm)	A0 (mm)	B0 (mm)	K0 (mm)	P1 (mm)	W (mm)	Pin1 Quadrant
TL432AQDBZRQ1	SOT-23	DBZ	3	3000	180.0	8.4	3.15	2.95	1.22	4.0	8.0	Q3
TL432BQDBZRQ1	SOT-23	DBZ	3	3000	179.0	8.4	3.15	2.95	1.22	4.0	8.0	Q3

TAPE AND REEL BOX DIMENSIONS

*All dimensions are nominal

Device	Package Type	Package Drawing	Pins	SPQ	Length (mm)	Width (mm)	Height (mm)
TL432AQDBZRQ1	SOT-23	DBZ	3	3000	203.0	203.0	35.0
TL432BQDBZRQ1	SOT-23	DBZ	3	3000	203.0	203.0	35.0

GENERIC PACKAGE VIEW

DBZ 3

SOT-23 - 1.12 mm max height

SMALL OUTLINE TRANSISTOR



Images above are just a representation of the package family, actual package may vary.
Refer to the product data sheet for package details.

4203227/C

DBZ0003A



PACKAGE OUTLINE

SOT-23 - 1.12 mm max height

SMALL OUTLINE TRANSISTOR

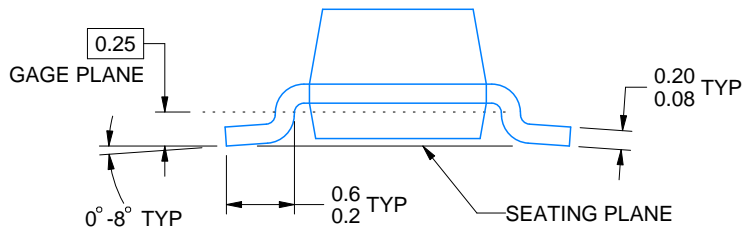

4214838/C 04/2017

NOTES:

1. All linear dimensions are in millimeters. Any dimensions in parenthesis are for reference only. Dimensioning and tolerancing per ASME Y14.5M.
2. This drawing is subject to change without notice.
3. Reference JEDEC registration TO-236, except minimum foot length.

EXAMPLE BOARD LAYOUT

DBZ0003A

SOT-23 - 1.12 mm max height

SMALL OUTLINE TRANSISTOR



LAND PATTERN EXAMPLE
SCALE:15X

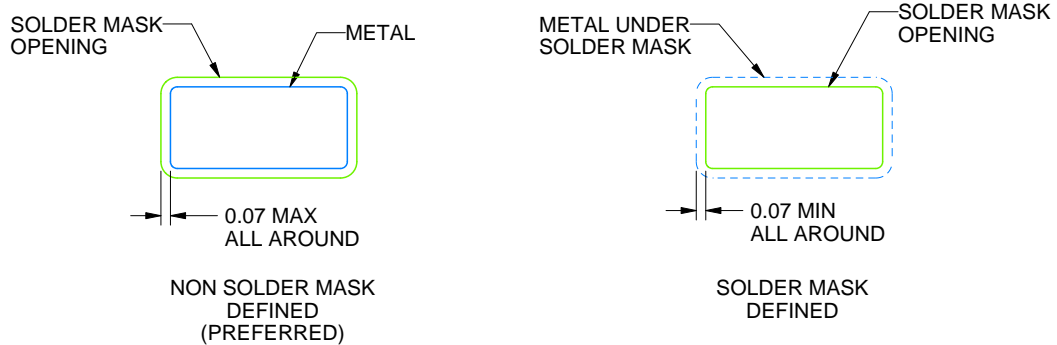

SOLDER MASK DETAILS

4214838/C 04/2017

NOTES: (continued)

4. Publication IPC-7351 may have alternate designs.
5. Solder mask tolerances between and around signal pads can vary based on board fabrication site.

EXAMPLE STENCIL DESIGN

DBZ0003A

SOT-23 - 1.12 mm max height

SMALL OUTLINE TRANSISTOR



SOLDER PASTE EXAMPLE
BASED ON 0.125 THICK STENCIL
SCALE:15X

4214838/C 04/2017

NOTES: (continued)

6. Laser cutting apertures with trapezoidal walls and rounded corners may offer better paste release. IPC-7525 may have alternate design recommendations.
7. Board assembly site may have different recommendations for stencil design.

IMPORTANT NOTICE

Texas Instruments Incorporated (TI) reserves the right to make corrections, enhancements, improvements and other changes to its semiconductor products and services per JESD46, latest issue, and to discontinue any product or service per JESD48, latest issue. Buyers should obtain the latest relevant information before placing orders and should verify that such information is current and complete.

TI's published terms of sale for semiconductor products (<http://www.ti.com/sc/docs/stdterms.htm>) apply to the sale of packaged integrated circuit products that TI has qualified and released to market. Additional terms may apply to the use or sale of other types of TI products and services.

Reproduction of significant portions of TI information in TI data sheets is permissible only if reproduction is without alteration and is accompanied by all associated warranties, conditions, limitations, and notices. TI is not responsible or liable for such reproduced documentation. Information of third parties may be subject to additional restrictions. Resale of TI products or services with statements different from or beyond the parameters stated by TI for that product or service voids all express and any implied warranties for the associated TI product or service and is an unfair and deceptive business practice. TI is not responsible or liable for any such statements.

Buyers and others who are developing systems that incorporate TI products (collectively, "Designers") understand and agree that Designers remain responsible for using their independent analysis, evaluation and judgment in designing their applications and that Designers have full and exclusive responsibility to assure the safety of Designers' applications and compliance of their applications (and of all TI products used in or for Designers' applications) with all applicable regulations, laws and other applicable requirements. Designer represents that, with respect to their applications, Designer has all the necessary expertise to create and implement safeguards that (1) anticipate dangerous consequences of failures, (2) monitor failures and their consequences, and (3) lessen the likelihood of failures that might cause harm and take appropriate actions. Designer agrees that prior to using or distributing any applications that include TI products, Designer will thoroughly test such applications and the functionality of such TI products as used in such applications.

TI's provision of technical, application or other design advice, quality characterization, reliability data or other services or information, including, but not limited to, reference designs and materials relating to evaluation modules, (collectively, "TI Resources") are intended to assist designers who are developing applications that incorporate TI products; by downloading, accessing or using TI Resources in any way, Designer (individually or, if Designer is acting on behalf of a company, Designer's company) agrees to use any particular TI Resource solely for this purpose and subject to the terms of this Notice.

TI's provision of TI Resources does not expand or otherwise alter TI's applicable published warranties or warranty disclaimers for TI products, and no additional obligations or liabilities arise from TI providing such TI Resources. TI reserves the right to make corrections, enhancements, improvements and other changes to its TI Resources. TI has not conducted any testing other than that specifically described in the published documentation for a particular TI Resource.

Designer is authorized to use, copy and modify any individual TI Resource only in connection with the development of applications that include the TI product(s) identified in such TI Resource. NO OTHER LICENSE, EXPRESS OR IMPLIED, BY ESTOPPEL OR OTHERWISE TO ANY OTHER TI INTELLECTUAL PROPERTY RIGHT, AND NO LICENSE TO ANY TECHNOLOGY OR INTELLECTUAL PROPERTY RIGHT OF TI OR ANY THIRD PARTY IS GRANTED HEREIN, including but not limited to any patent right, copyright, mask work right, or other intellectual property right relating to any combination, machine, or process in which TI products or services are used. Information regarding or referencing third-party products or services does not constitute a license to use such products or services, or a warranty or endorsement thereof. Use of TI Resources may require a license from a third party under the patents or other intellectual property of the third party, or a license from TI under the patents or other intellectual property of TI.

TI RESOURCES ARE PROVIDED "AS IS" AND WITH ALL FAULTS. TI DISCLAIMS ALL OTHER WARRANTIES OR REPRESENTATIONS, EXPRESS OR IMPLIED, REGARDING RESOURCES OR USE THEREOF, INCLUDING BUT NOT LIMITED TO ACCURACY OR COMPLETENESS, TITLE, ANY EPIDEMIC FAILURE WARRANTY AND ANY IMPLIED WARRANTIES OF MERCHANTABILITY, FITNESS FOR A PARTICULAR PURPOSE, AND NON-INFRINGEMENT OF ANY THIRD PARTY INTELLECTUAL PROPERTY RIGHTS. TI SHALL NOT BE LIABLE FOR AND SHALL NOT DEFEND OR INDEMNIFY DESIGNER AGAINST ANY CLAIM, INCLUDING BUT NOT LIMITED TO ANY INFRINGEMENT CLAIM THAT RELATES TO OR IS BASED ON ANY COMBINATION OF PRODUCTS EVEN IF DESCRIBED IN TI RESOURCES OR OTHERWISE. IN NO EVENT SHALL TI BE LIABLE FOR ANY ACTUAL, DIRECT, SPECIAL, COLLATERAL, INDIRECT, PUNITIVE, INCIDENTAL, CONSEQUENTIAL OR EXEMPLARY DAMAGES IN CONNECTION WITH OR ARISING OUT OF TI RESOURCES OR USE THEREOF, AND REGARDLESS OF WHETHER TI HAS BEEN ADVISED OF THE POSSIBILITY OF SUCH DAMAGES.

Unless TI has explicitly designated an individual product as meeting the requirements of a particular industry standard (e.g., ISO/TS 16949 and ISO 26262), TI is not responsible for any failure to meet such industry standard requirements.

Where TI specifically promotes products as facilitating functional safety or as compliant with industry functional safety standards, such products are intended to help enable customers to design and create their own applications that meet applicable functional safety standards and requirements. Using products in an application does not by itself establish any safety features in the application. Designers must ensure compliance with safety-related requirements and standards applicable to their applications. Designer may not use any TI products in life-critical medical equipment unless authorized officers of the parties have executed a special contract specifically governing such use. Life-critical medical equipment is medical equipment where failure of such equipment would cause serious bodily injury or death (e.g., life support, pacemakers, defibrillators, heart pumps, neurostimulators, and implantables). Such equipment includes, without limitation, all medical devices identified by the U.S. Food and Drug Administration as Class III devices and equivalent classifications outside the U.S.

TI may expressly designate certain products as completing a particular qualification (e.g., Q100, Military Grade, or Enhanced Product). Designers agree that it has the necessary expertise to select the product with the appropriate qualification designation for their applications and that proper product selection is at Designers' own risk. Designers are solely responsible for compliance with all legal and regulatory requirements in connection with such selection.

Designer will fully indemnify TI and its representatives against any damages, costs, losses, and/or liabilities arising out of Designer's non-compliance with the terms and provisions of this Notice.