



MULTI-INNO TECHNOLOGY CO., LTD.

LCD MODULE SPECIFICATION

Model : MI1040GT-1

Revision	0.1
Engineering	
Date	
Our Reference	



Table of Contents

Coversheet.....	1
Table of Contents.....	2
Record of Revision.....	3
1 General Specifications.....	4
2 Input/Output Terminals.....	5
3 Absolute Maximum Ratings.....	6
4 Electrical Characteristics.....	6
5 Timing Chart.....	8
6 Optical Characteristics.....	10
7 Environmental / Reliability Test.....	14
8 Mechanical Drawing.....	15
9 Packing Drawing.....	17
10 Precautions For Use of LCD Modules.....	18



Record of Revision

Rev	Issued Date	Description	Editor
0.0	2008-10-28	Provisional draft spec release	
0.1	2008-11-20	Update Product Number	

1 General Specifications

Feature		Spec
Display Spec.	Size	10.4 inch
	Resolution	800(RGB) x 600
	Interface	LVDS 6 bits
	Color Depth	262K
	Technology Type	a-Si
	Pixel Pitch (mm)	0.264x0.264
	Pixel Configuration	R.G.B. Vertical Stripe
	Display Mode	TM with Normally White
	Surface Treatment(Up Polarizer)	Anti-Glare(3H)
	Viewing Direction	12 o'clock
	Gray Scale Inversion Direction	6 o'clock
Mechanical Characteristics	LCM (W x H x D) (mm)	236.00x176.90x5.60
	Active Area(mm)	211.20x158.40
	With /Without TSP	Without TSP
	Weight (g)	TBD

Note 1: Viewing direction for best image quality is different from TFT definition, there is a 180 degree shift.

Note 2 : Requirements on Environmental Protection: RoHS

Note 3 : LCM weight tolerance : +/- 5%

2 Input/Output Terminals

2.1 TFT LCD Panel

Matching connector of Hirose DF19K-20P-1H (56)

No	Symbol	I/O	Description	Comment
1	VDD	P	Power Supply	
2	VDD	P	Power Supply	
3	GND	P	Ground	
4	GND	P	Ground	
5	IN0-	I	LVDS receiver negative signal channel 0	
6	IN0+	I	LVDS receiver positive signal channel 0	
7	GND	P	Ground	
8	IN1-	I	LVDS receiver negative signal channel 1	
9	IN1+	I	LVDS receiver positive signal channel 1	
10	GND	P	Ground	
11	IN2-	I	LVDS receiver negative signal channel 2	
12	IN2+	I	LVDS receiver positive signal channel 2	
13	GND	P	Ground	
14	CLK-	I	LVDS receiver negative signal clock	
15	CLK+	I	LVDS receiver positive signal clock	
16	GND	P	Ground	
17	NC	-	No connection	
18	NC	-	No connection	
19	GND	P	Ground	
20	GND	P	Ground	

Note: I/O definition:

I----Input O---Output P----Power/Ground

2.2 CN2 (LED connector)

No	Symbol	I/O	Description	Wire Color
1	VL1	P	LED power supply(high voltage)	Red
2	VL2	P	LED power supply(GND)	White

3 Absolute Maximum Ratings

3.1 Driving TFT LCD Panel

GND=0V, Ta = 25°C

Item	Symbol	Min	Max	Unit	Remark
Power Voltage	VDD	-0.3	5.0	V	
Input voltage	V _{IN}	-0.3	5.0	V	Note1
Operating Temperature	T _{OPR}	-20	70	°C	
Storage Temperature	T _{STG}	-30	80	°C	

Note1: V_{IN} represent IN0±, IN1±, IN2±, CLK±

4 Electrical Characteristics

4.1 Driving TFT LCD Panel

GND=0V, Ta=25°C

Item	Symbol	Min	Typ	Max	Unit	Remark
LVDS Differential input high threshold	V _{TH}	-	-	+100	mV	V _{CMLVDS} =1.2V
LVDS Differential input low threshold	V _{TL}	-100	-	-	mV	V _{CMLVDS} =1.2V
Differential input voltage	V _{ID}	0.1	-	0.6	V	
LVDS input common mode voltage	V _{CMLVDS}	V _{ID} /2	-	1.4-(V _{ID} /2)	V	
Input current	I _{IN}	-10	-	10	μA	
Supply Voltage	VDD	3.0	3.3	3.6	V	
Common Electrode Driving Signal	VCOM	-	4.36	-	V	Note1
Sync Frequency	FVD	-	60	70	Hz	
VDD Power Consumption	I _{DD}	-	TBD	380	mA	Note2

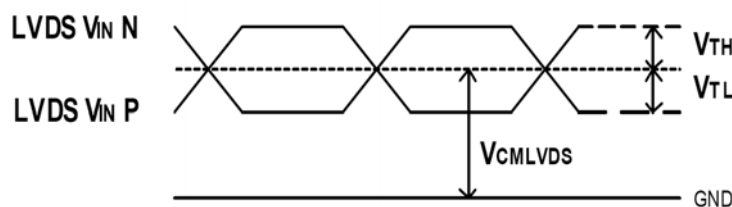

Figure 4.1.1 LVDS DC timing diagram

Note1: The value may be different for different LCM.

Note2: To test the current dissipation, using the “color bar” testing pattern shown as below:

1. White
2. Yellow
3. Cyan
4. Green
5. Magenta
6. Red
7. Blue
8. Black

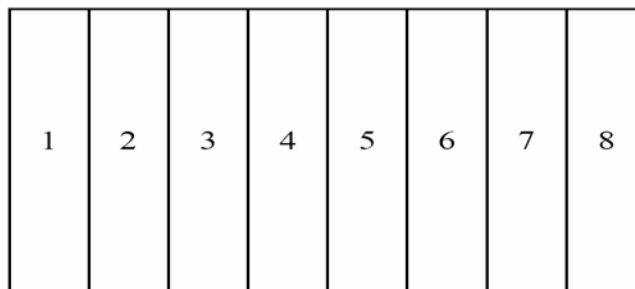
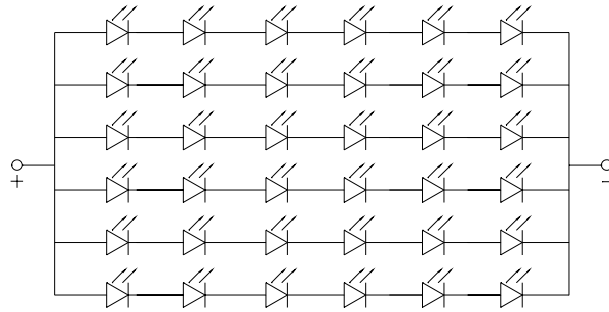

Figure 4.1.2 Current dissipation testing pattern

4.2 Driving Backlight

Item	Symbol	MIN	TYP	MAX	Unit	Remark
Forward Current	I_F	-	120	-	mA	
Forward Current Voltage	V_F	-	19.2	-	V	reference
Backlight Power Consumption	W_{BL}	-	2.3	-	mW	



4.3 Block Diagram

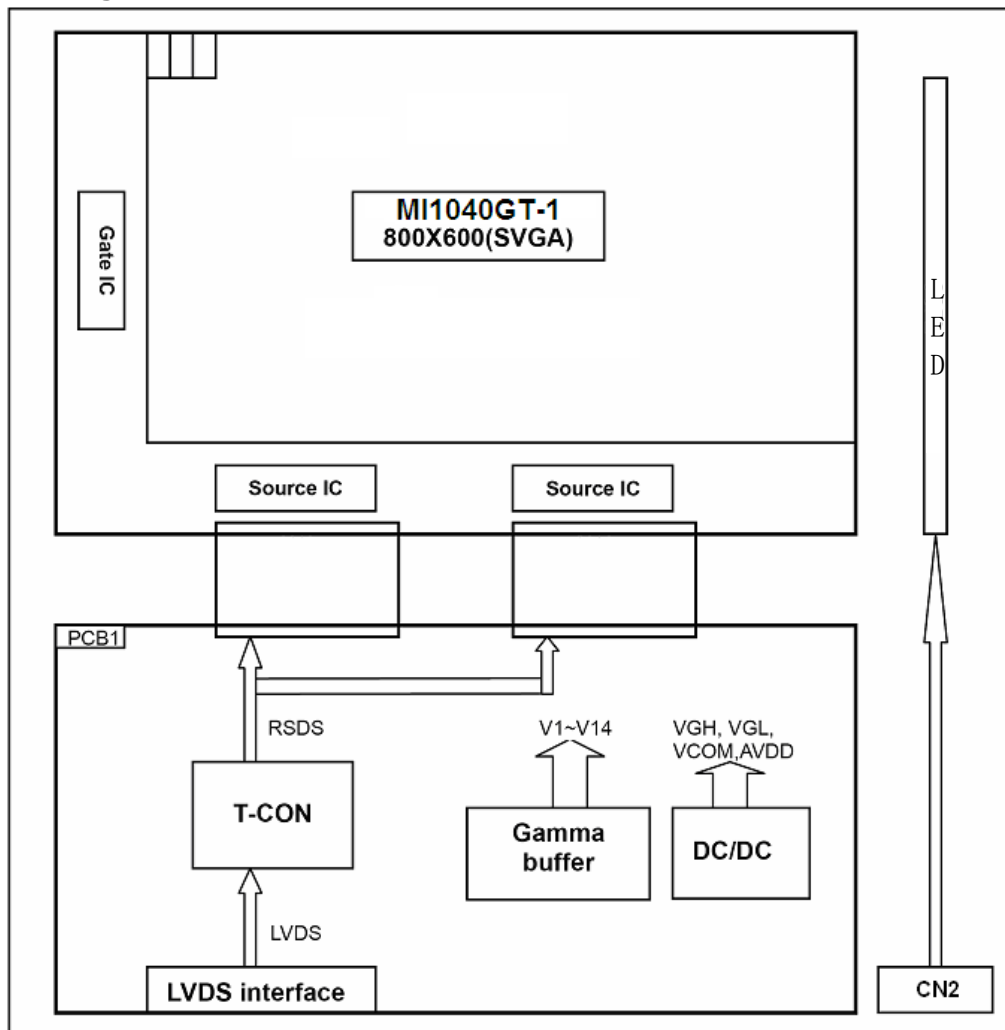

5 Timing Chart

5.1 Timing Parameter

Item	Symbol	Min	Typ	Max	Unit	Condition
Clock period	tLVCP	20.0	25	31.25	ns	
Clock high time	tLVCH	-	14.29	-	ns	
Clock low time	tLVCL	-	10.71	-	ns	
PLL wake-up time	tLVPLL	-	-	1	ms	
Input skew margin	tLVSKM	400	-	-	ps	f=85MHz

Table 5.1 timing parameter

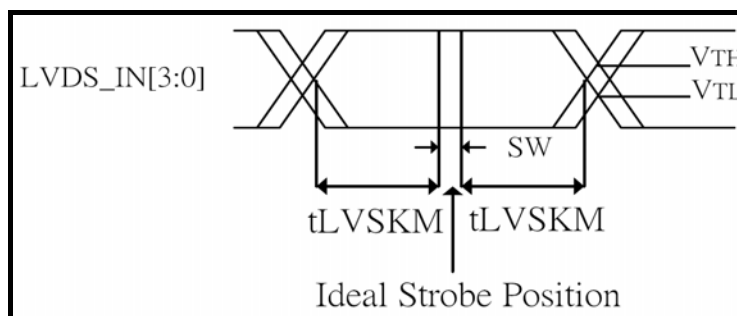
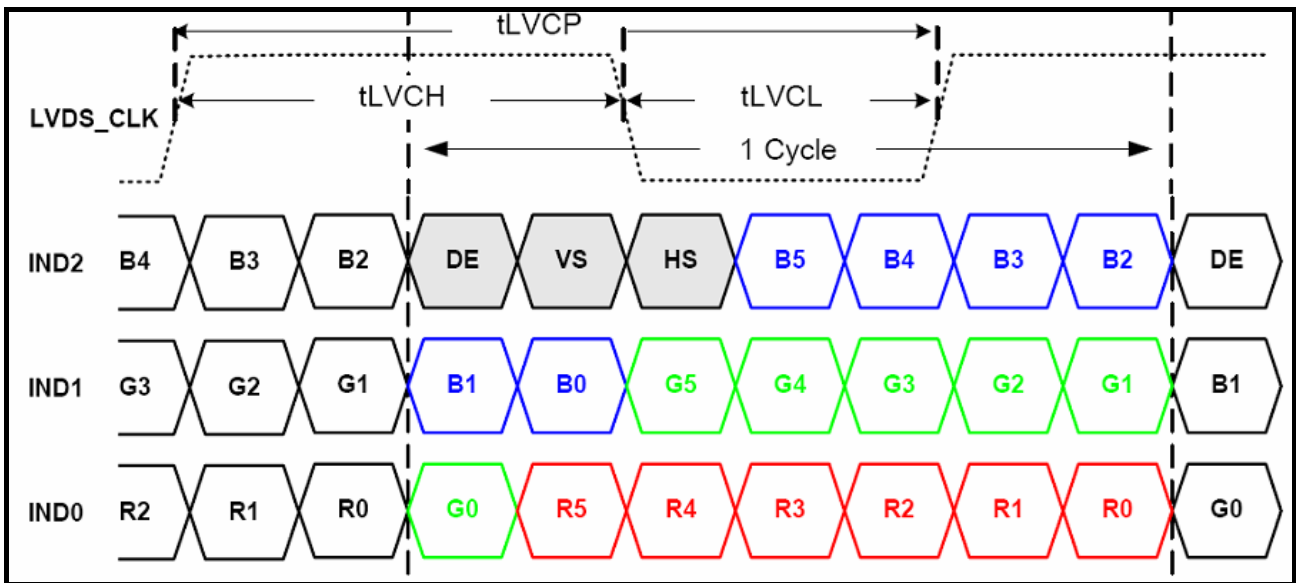
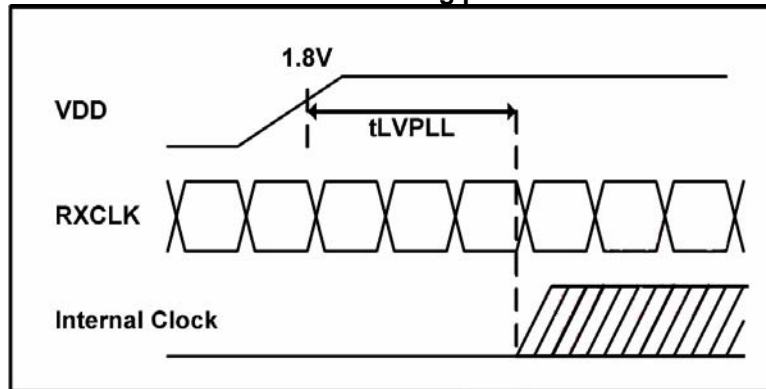

SW: Setup and Hold time
Figure 5.1 Input signal data timing

5.2 Power On/Off Sequence

Item	Symbol	Min	Typ	Max	Unit	Remark
VDD 3.0V to signal starting	Tp1	0	-	30	ms	
Signal starting to backlight on	Tp2	0	-	-	ms	
Signal off to VDD 3.0V	Tp3	0	-	30	ms	
Backlight off to signal off	Tp4	0	-	-	ms	

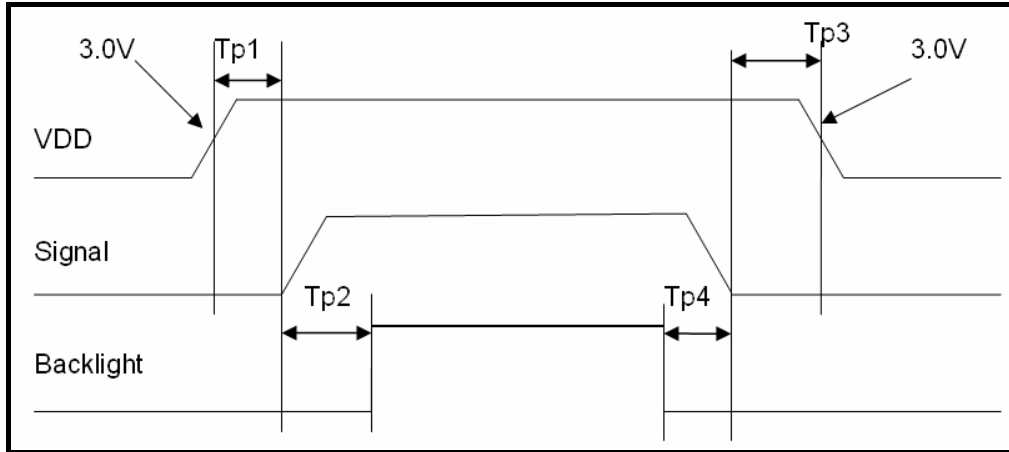
Figure 5.2 Interface power on/off sequenc

6 Optical Characteristics

6.1 Optical Specification

 $T_a=25^{\circ}\text{C}$

Item	Symbol	Condition	Min	Typ	Max	Unit	Remark
View Angles	θT	$CR \geq 10$	35	45	-	Degree	Note 2
	θB		55	65	-		
	θL		55	65	-		
	θR		55	65	-		
Contrast Ratio	CR	$\theta=0^{\circ}$	300	400	-	-	Note1 Note3
Response Time	T_{ON}	25°C	-	25	50	ms	Note1
	T_{OFF}						Note4
Chromaticity	White	Backlight is on		TBD		-	Note5
				TBD			Note1
Uniformity	U	-	-	80	-	%	Note1 Note6
NTSC	-	-	-	TBD	-	%	Note 5
Luminance	L		350	400	-	cd/m^2	Note1 Note7

Test Conditions:

1. The ambient temperature is $25 \pm 2^{\circ}\text{C}$. humidity is $65 \pm 7\%$
2. The test systems refer to Note 1 and Note 2.

Note 1: Definition of optical measurement system.

The optical characteristics should be measured in dark room. After 5 minutes operation, the optical properties are measured at the center point of the LCD screen. All input terminals LCD panel must be ground when measuring the center area of the panel.

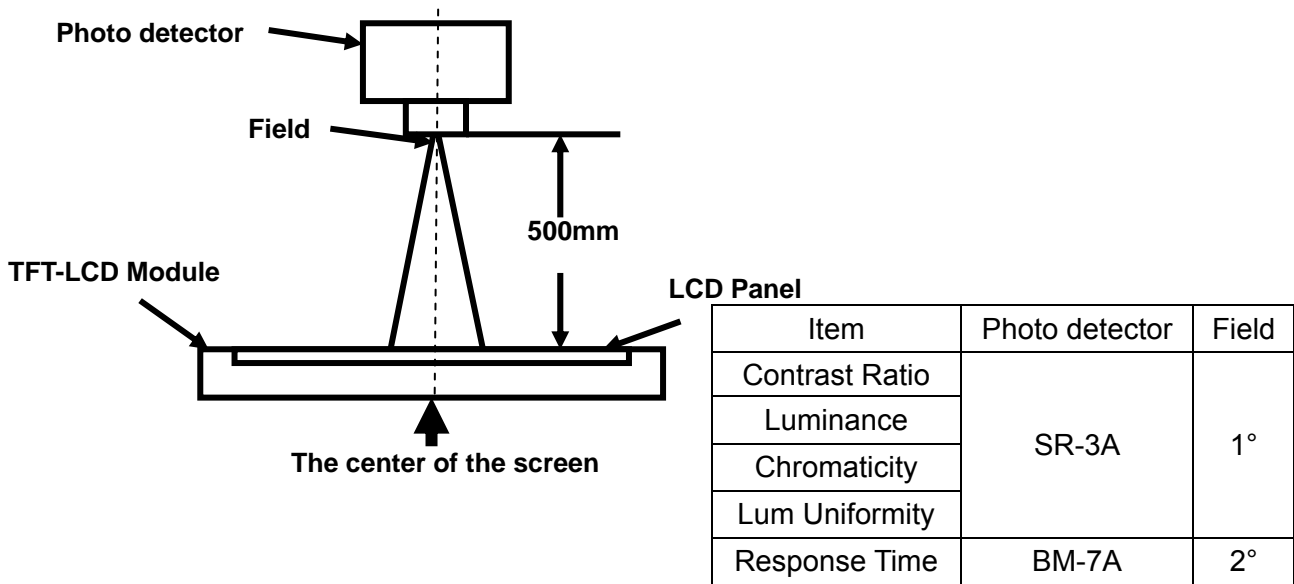
Note 2: Definition of viewing angle range and measurement system.

viewing angle is measured at the center point of the LCD by CONOSCOPE(ergo-80).

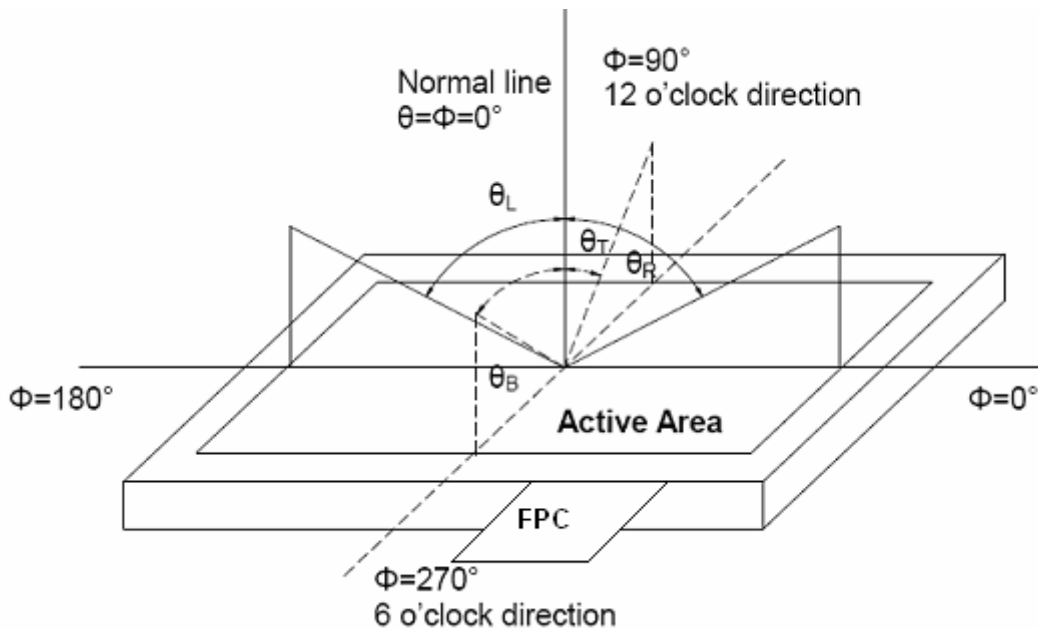

Fig. 1 Definition of viewing angle

Note 3: Definition of contrast ratio

$$\text{Contrast ratio (CR)} = \frac{\text{Luminance measured when LCD is on the "White" state}}{\text{Luminance measured when LCD is on the "Black" state}}$$

“White state “:The state is that the LCD should driven by V_{white} .

“Black state”: The state is that the LCD should driven by V_{black} .

V_{white} : To be determined V_{black} : To be determined.

Note 4: Definition of Response time

The response time is defined as the LCD optical switching time interval between “White” state and “Black” state. Rise time (T_{ON}) is the time between photo detector output intensity changed from 90% to 10%. And fall time (T_{OFF}) is the time between photo detector output intensity changed from 10% to 90%.

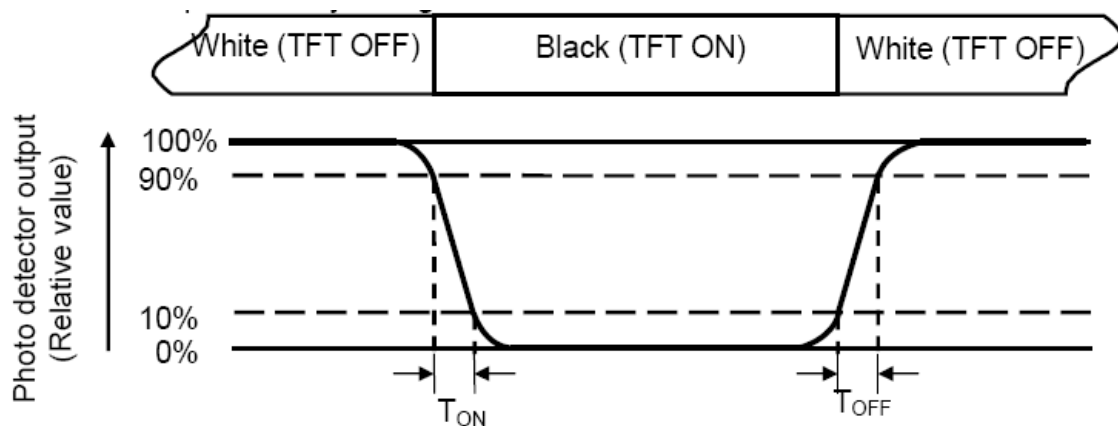
Note 5: Definition of color chromaticity (CIE1931)

Color coordinates measured at center point of LCD.

Note 6: Definition of Luminance Uniformity

Active area is divided into 9 measuring areas (Refer Fig. 2). Every measuring point is placed at the center of each measuring area.

$$\text{Luminance Uniformity}(U) = L_{\min} / L_{\max}$$

L-----Active area length W----- Active area width

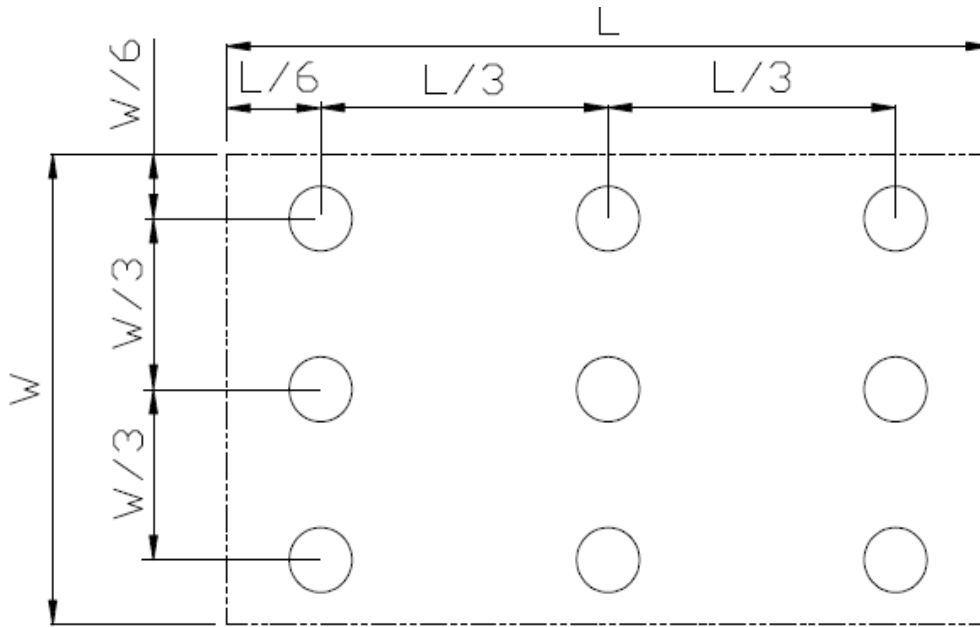

Fig. 2 Definition of uniformity

L_{\max} : The measured maximum luminance of all measurement position.

L_{\min} : The measured minimum luminance of all measurement position.

Note 7: Definition of Luminance :

Measure the luminance of white state at center point.

7 Environmental / Reliability Test

No	Test Item	Condition	Remark
1	High Temperature Operation	Ts=+70°C, 240hrs	Note1 IEC60068-2-2,GB2423.2—89
2	Low Temperature Operation	Ta=-20°C, 240hrs	IEC60068-2-1 GB2423.1—89
3	High Temperature Storage (non-operation)	Ta=+80°C, 240hrs	IEC60068-2-2, GB2423.2—89
4	Low Temperature Storage (non-operation)	Ta=-30°C, 240hrs	IEC60068-2-1 GB2423.1—89
5	High Temperature & High Humidity Operation	Ta = +60°C, 90% RH max,240 hours	Note2 IEC60068-2-3, GB/T2423.3—2006
6	Thermal Shock (non-operation)	-20°C 30 min~+70°C 30 min, Change time:5min, 100 Cycles	Start with cold temperature, end with high temperature IEC60068-2-14,GB2423.22—87
7	Electro Static Discharge (operation)	C=150pF,R=330Ω, Air:±15Kv, Contact:±8Kv, 10times/terminal	IEC61000-4-2 GB/T17626.2—1998
8	Vibration (non-operation)	Frequency range:10~55Hz, Stroke:1.5mm Sweep:10Hz~55Hz~10Hz 2hours for each direction of X.y.z (6 hours for total)	IEC60068-2-6 GB/T2423.10—1995
9	Shock (non-operation)	80G 6ms, ±X,±Y,±Z 3 times for each direction	IEC60068-2-27 GB/T2423.5—1995
10	Package Drop Test	Height:80 cm,1 corner, 3 edges, 6 surfaces	IEC60068-2-32 GB/2423.8—1995
11	Package Vibration Test	Random Vibration: 0.015GxG/Hz for 5-200Hz, -6dB/Octave from 200-500Hz 2 hours for each direction of X,Y,Z (6 hours for total)	IEC60068-2-34

Note1: Ts is the temperature of panel's surface.

Note2: Ta is the ambient temperature of sample.

8 Mechanical Drawing

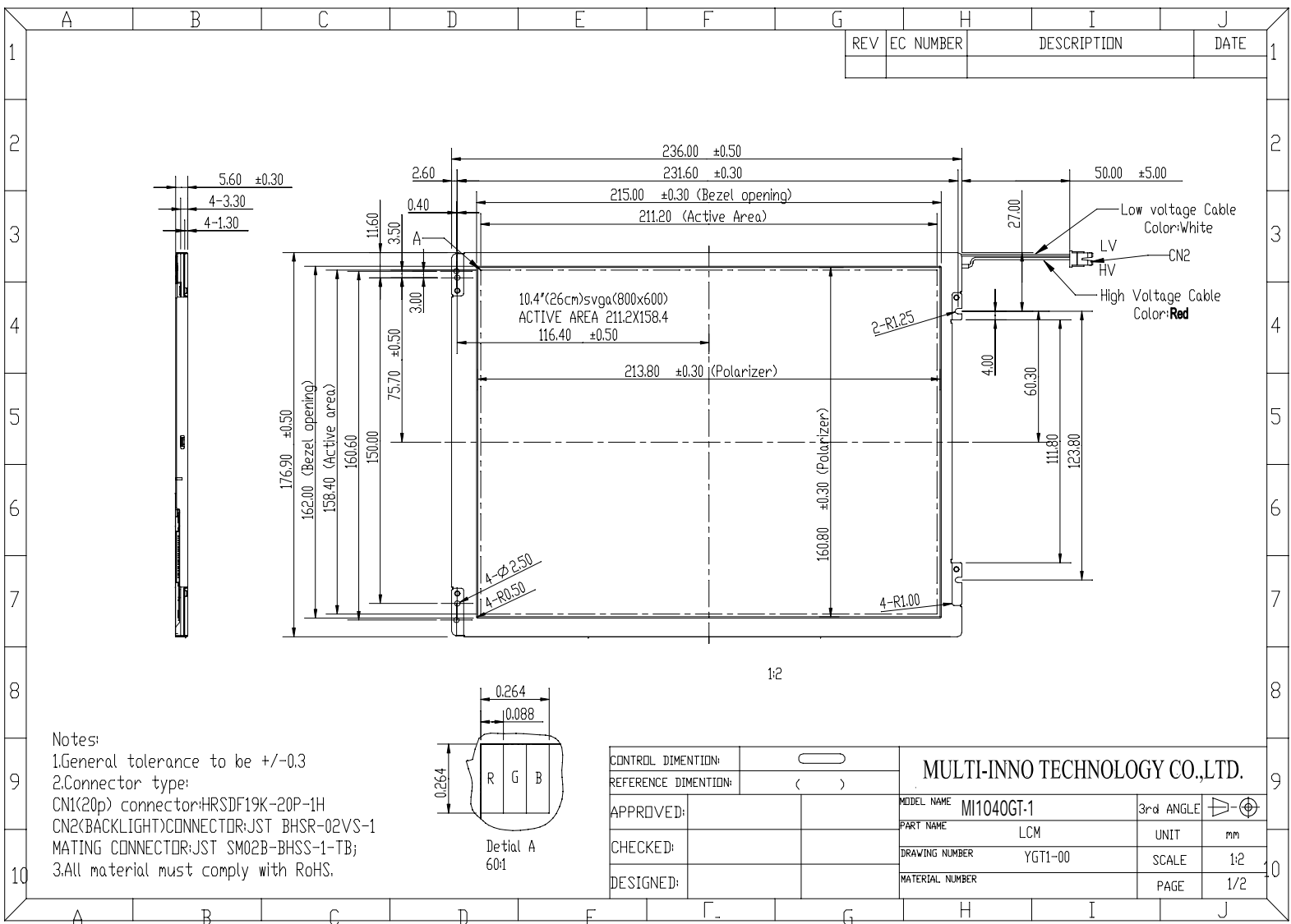



MODULE NO.: M11040GT-1

Ver 0.1

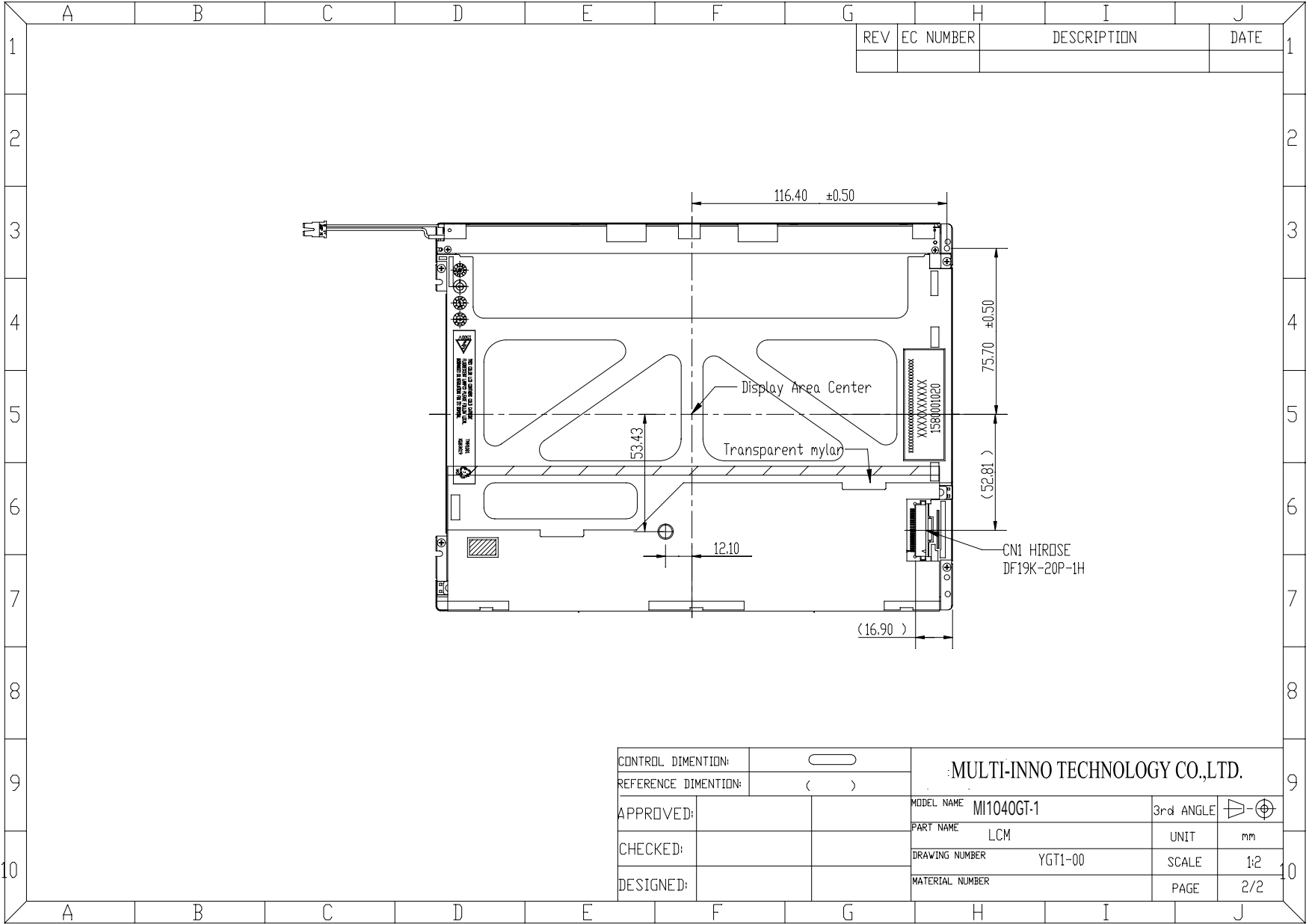

9 Packing Drawing

No	Item	Model (Material)	Dimensions(mm)	Unit Weight(Kg)	Quantity	Remark
1	LCM module	MI1040GT-1	236.00x176.90x5.60	0.29	25	
2	Partition_1	CORRUGATED PAPER	513x333x217	1.96	1	
3	Anti-static Bag	PE	247x256x0.05	0.04	25	
4	DUST-PROOF BAG	PE	700x530	0.06	1	
5	Partition_1	CORRUGATED PAPER	505x332x4.0	0.1	2	
6	CORRUGATED	CORRUGATED PAPER	513x248	0.09	2	
7	Carton	CORRUGATED PAPER	530x350x250	1.12	1	
8	Total weight(Kg)		11.8			

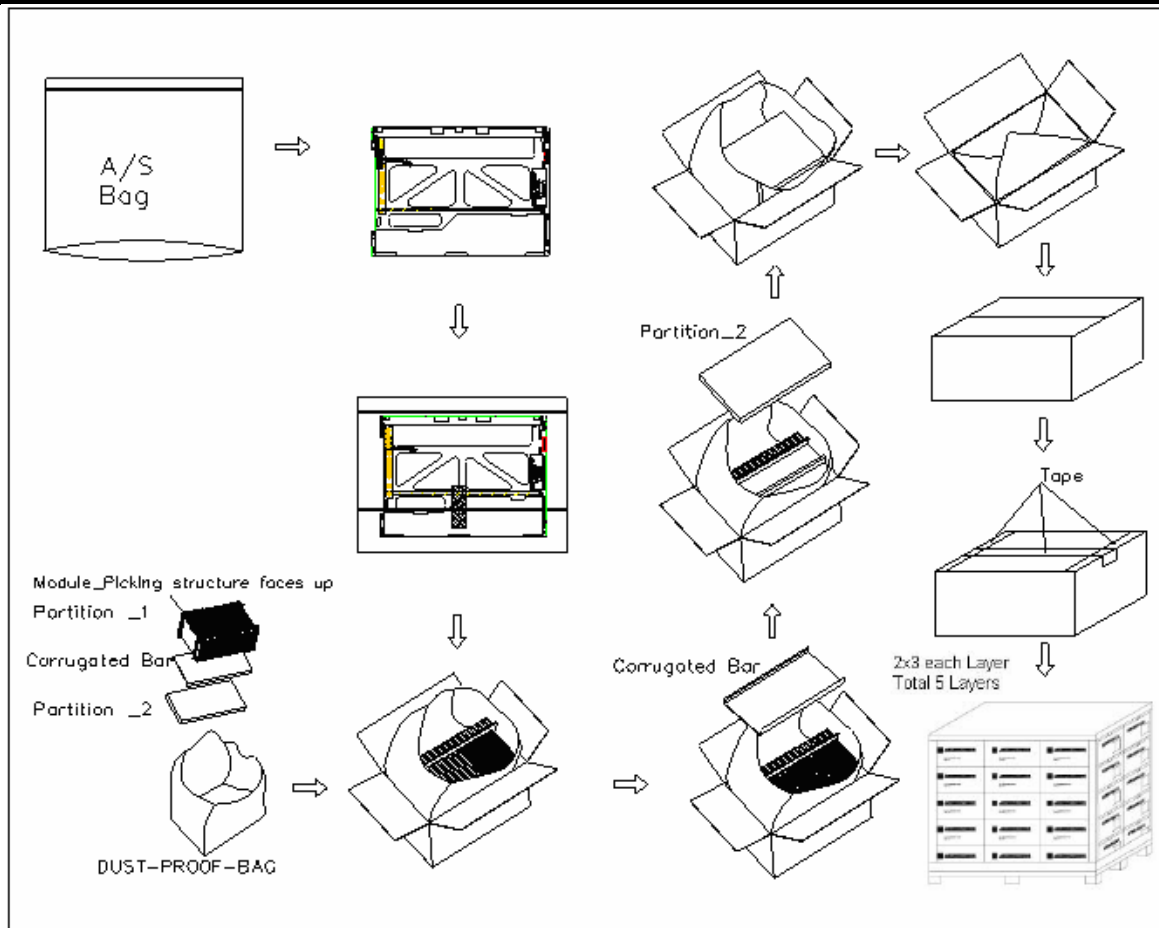

10 Precautions For Use of LCD Modules

10.1 Handling Precautions

- 10.1.1 The display panel is made of glass. Do not subject it to a mechanical shock by dropping it from a high place, etc.
- 10.1.2 If the display panel is damaged and the liquid crystal substance inside it leaks out, be sure not to get any in your mouth, if the substance comes into contact with your skin or clothes, promptly wash it off using soap and water.
- 10.1.3 Do not apply excessive force to the display surface or the adjoining areas since this may cause the color tone to vary.
- 10.1.4 The polarizer covering the display surface of the LCD module is soft and easily scratched. Handle this polarizer carefully.
- 10.1.5 If the display surface is contaminated, breathe on the surface and gently wipe it with a soft dry cloth. If still not completely clear, moisten cloth with one of the following solvents:
 - Isopropyl alcohol
 - Ethyl alcoholSolvents other than those mentioned above may damage the polarizer. Especially, do not use the following:
 - Water
 - Ketone
 - Aromatic solvents
- 10.1.6 Do not attempt to disassemble the LCD Module.
- 10.1.7 If the logic circuit power is off, do not apply the input signals.
- 10.1.8 To prevent destruction of the elements by static electricity, be careful to maintain an optimum work environment.
 - 10.1.8.1 Be sure to ground the body when handling the LCD Modules.
 - 10.1.8.2 Tools required for assembly, such as soldering irons, must be properly ground.
 - 10.1.8.3 To reduce the amount of static electricity generated, do not conduct assembly and other work under dry conditions.
 - 10.1.8.4 The LCD Module is coated with a film to protect the display surface. Be care when peeling off this protective film since static electricity may be generated.

10.2 Storage Precautions

- 10.2.1 When storing the LCD modules, avoid exposure to direct sunlight or to the light of fluorescent lamps.
- 10.2.2 The LCD modules should be stored under the storage temperature range. If the LCD modules will be stored for a long time, the recommend condition is:
Temperature : 0°C ~ 40°C Relatively humidity: ≤80%
- 10.2.3 The LCD modules should be stored in the room without acid, alkali and harmful gas.

10.3 Transportation Precautions

The LCD modules should be no falling and violent shocking during transportation, and also should avoid excessive press, water, damp and sunshine.