



SANYO Semiconductors

DATA SHEET

LA42051

Monolithic Linear IC
— Audio Output for TV Application
5W×1ch Power Amplifier

Overview

LA42051 is 5W 1-channel AF power amplifier intended for televisions.

Features

- P_{O1} 5W×1ch (V_{CC} = 18V, R_L = 8Ω)
- Built-in standby function
- Pop noise reduction function
- Ripple filter
- Thermal protection circuit

LA42000 series is power IC which made Pin compatible altogether in 5 to 15W. They consist of four kinds of power ICs (mono, stereo, mono with volume function, stereo with volume function. They realized PCB layout communalization of an audio power block of TV).

Model name	P _O	Channel		Volume
		Monaural	Stereo	
LA42051	5W	○		
LA42052	5W		○	
LA42351	5W	○		○
LA42352	5W		○	○
LA42071	7W	○		
LA42072	7W		○	
LA42152	15W		○	

■ Any and all SANYO Semiconductor Co.,Ltd. products described or contained herein are, with regard to "standard application", intended for the use as general electronics equipment (home appliances, AV equipment, communication device, office equipment, industrial equipment etc.). The products mentioned herein shall not be intended for use for any "special application" (medical equipment whose purpose is to sustain life, aerospace instrument, nuclear control device, burning appliances, transportation machine, traffic signal system, safety equipment etc.) that shall require extremely high level of reliability and can directly threaten human lives in case of failure or malfunction of the product or may cause harm to human bodies, nor shall they grant any guarantee thereof. If you should intend to use our products for applications outside the standard applications of our customer who is considering such use and/or outside the scope of our intended standard applications, please consult with us prior to the intended use. If there is no consultation or inquiry before the intended use, our customer shall be solely responsible for the use.

■ Specifications of any and all SANYO Semiconductor Co.,Ltd. products described or contained herein stipulate the performance, characteristics, and functions of the described products in the independent state, and are not guarantees of the performance, characteristics, and functions of the described products as mounted in the customer's products or equipment. To verify symptoms and states that cannot be evaluated in an independent device, the customer should always evaluate and test devices mounted in the customer's products or equipment.

SANYO Semiconductor Co., Ltd.

TOKYO OFFICE Tokyo Bldg., 1-10, 1 Chome, Ueno, Taito-ku, TOKYO, 110-8534 JAPAN

LA42051

Specifications

Absolute Maximum Ratings at $T_a = 25^\circ\text{C}$

Parameter	Symbol	Conditions	Ratings	Unit
Maximum supply voltage	V_{CC} max	No signal	24	V
Allowable power dissipation	P_d max	Infinite heat sink	15	W
Maximum junction temperature	T_j max		150	$^\circ\text{C}$
Thermal resistance	θ_{jc}		3	$^\circ\text{C}/\text{W}$
Operating temperature	T_{opr}		-25 to +75	$^\circ\text{C}$
Storage temperature	T_{stg}		-40 to +150	$^\circ\text{C}$

Operating Condition at $T_a = 25^\circ\text{C}$

Parameter	Symbol	Conditions	Ratings	Unit
Recommended supply voltage	V_{CC}		18	V
Recommended load resistance	R_L		8	Ω
Allowable operating supply voltage range	V_{CC} op		5.5 to 22	V

Operating Characteristics at $T_a = 25^\circ\text{C}$, $V_{CC} = 18\text{V}$, $R_L = 8\Omega$, $f = 1\text{kHz}$, $R_g = 600\Omega$

Parameter	Symbol	Conditions	Ratings			Unit
			min	typ	max	
Standby current	I_{STB}	Amplifier off		1	10	μA
Quiescent current	I_{CCO}	$R_g = 0\Omega$	15	25	50	mA
Output power	P_O	THD = 10%	4	5		W
Total harmonic distortion	THD	$P_O = 1\text{W}$		0.15	0.4	%
Voltage gain	VG	$V_O = 0\text{dBm}$	33	35	37	dB
Output noise voltage	V_{NO}	$R_g = 0\Omega$, BPF = 20Hz to 20kHz		0.05	0.25	mVrms
Ripple rejection	SVRR	$R_g = 0\Omega$, $f_R = 100\text{Hz}$, $V_{CCR} = 0\text{dBm}$	50	60		dB
Standby control voltage (Pin 5)	V_{STB-H}	Amplifier on	1		5	V
	V_{STB-L}	Amplifier off	0		0.5	V
Input resistance	R_i		21	30	39	$\text{k}\Omega$

Package Dimensions

unit : mm (typ)

3107B

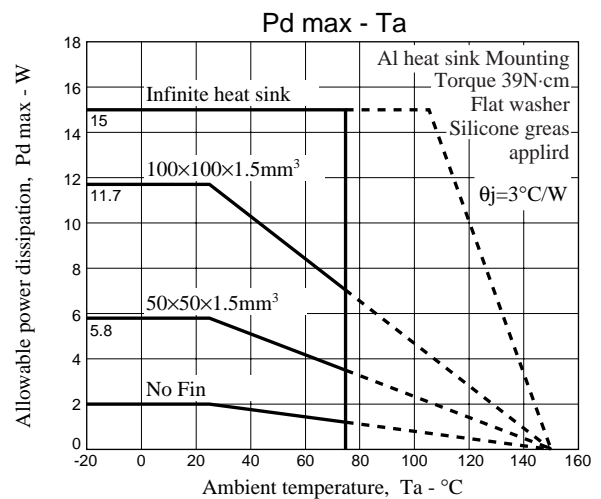
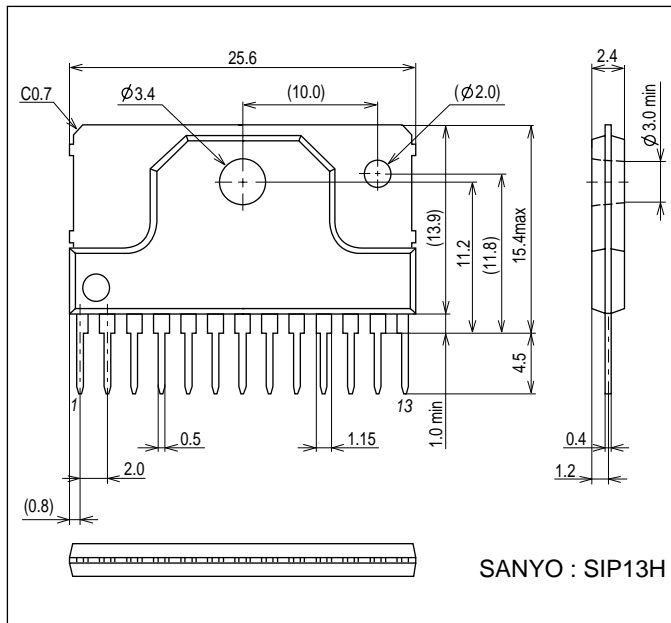

LA42051

Block Diagram

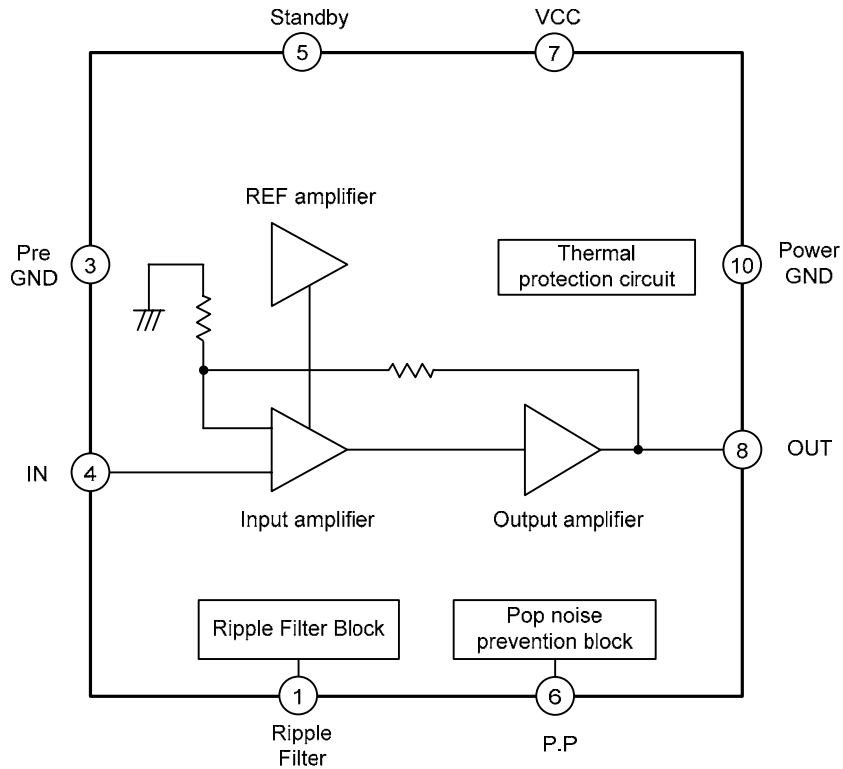

Test Circuit

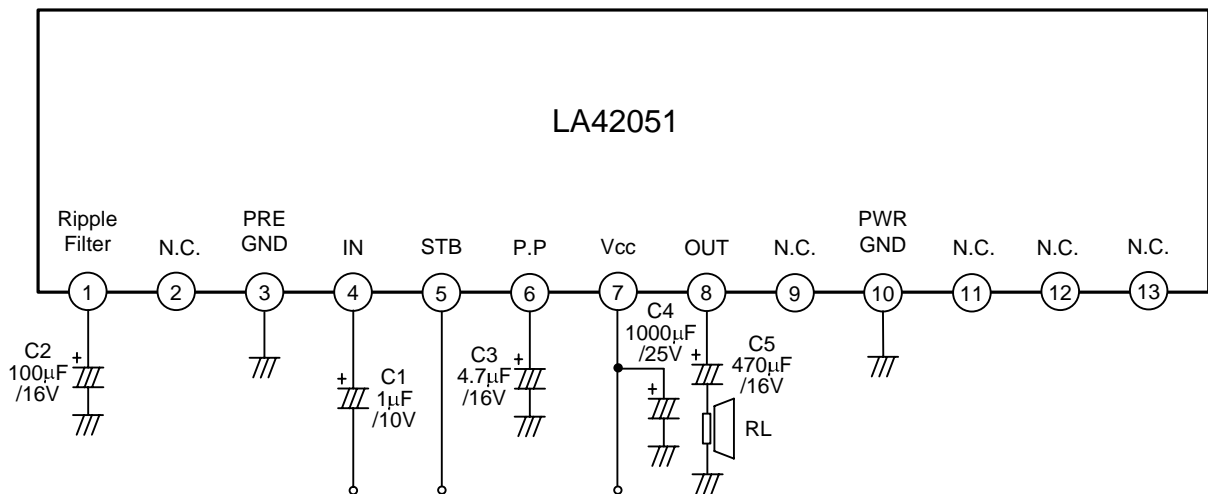

Description of External parts

- C1 : Input coupling capacitor, for which 1.0µF is recommended. The potential of input pin is $2V_{BE}$ (about 1.4V). Therefore, the polarity must be determined according to the DC potential of the circuit connected to the previous step of LA42051.
- C2 : Capacitor for ripple filter, for which 100µF is recommended.
- C3 : Capacitor for attenuation of pop noise, for which 4.7µF is recommended.
- C4 : Power supply capacitor.
- C5 : Output capacitor, for which 470µF is recommended. Determine the constant while taking into account a fact that, with the capacitance set to 470µF or less, the roll-off frequency decreases in the low range.

1. Standby function (pin 5)

The amplifier can be turned ON/OFF through HIGH/LOW control of pin 5.

The amplifier is turned ON when the voltage of 1.0V (min) or more is applied to pin 5.

Pin 5 control voltage

Voltage of pin 5	Amplifier	Standby
0 to 0.5	OFF	ON
1.0 to 5.0	ON	OFF

Insert a limiting resistor (RSTB) when the inrush current to pin 5 is to be limited if the application voltage to VS is high.

Example: when VS=5V, RSTB=5.1kΩ is inserted

The inrush current to pin 5 is about 750μA and the potential of pin 5 is about 1.2V.

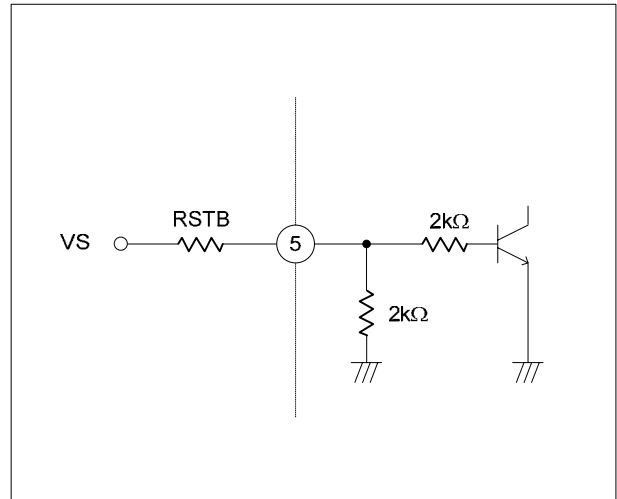

2. Ripple filter and MUTE function (Pin 1)

The potential of pin 1 is about 1/2 VCC. Muting to control the output signal becomes effective by shifting down pin 1 with 300 to 500Ω. Note that the MUTE suppression rate decreases when the resistance exceeds 750Ω.

3. Input pin (Pin 4)

The potential of input pin is 2VBE (about 1.4V). Therefore, the polarity must be determined according to the DC potential of the circuit connected to the previous step of LA42051. The standard input resistance is 30kΩ.

For the input capacitor, 1.0μF is recommended. The starting time with power ON in this case is about 0.2s.

The starting time becomes about 1.5s when the capacitance is 10μF.

4. P.P (Pin 6)

This is the pin to attenuate the pop noise during power ON/OFF. Note that, with the capacitance set at 10μF or more, the sound may remain because the signal is not cut off.

$$\text{Pin 6 potential} = \frac{V_{CC} - V_{CE} \text{ (about 0.3V)} - 5.6V}{2} + 5.6V$$

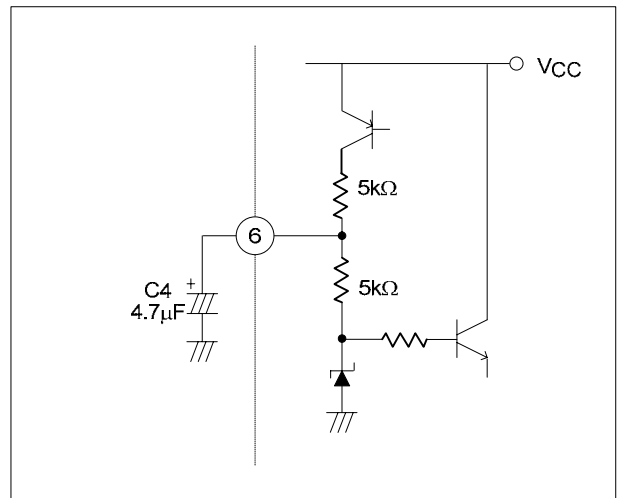

Cautions for use

- As power fault (power supply - output short-circuit) and ground fault (GND - output short-circuit) protective circuits are not incorporated, due care must be taken during use.
- The thermal protective circuit is incorporated, which is activated when the junction temperature (Tj) rises to about 160°C or more, controlling the output gradually to the attenuated condition.
- During use near the maximum rating, the product may suffer damage if the slightest fluctuation of condition exceeds the maximum rating. Be sure to use the product within a range which never exceeds the maximum rating while allowing sufficient margin for the supply voltage, etc.

LA42051

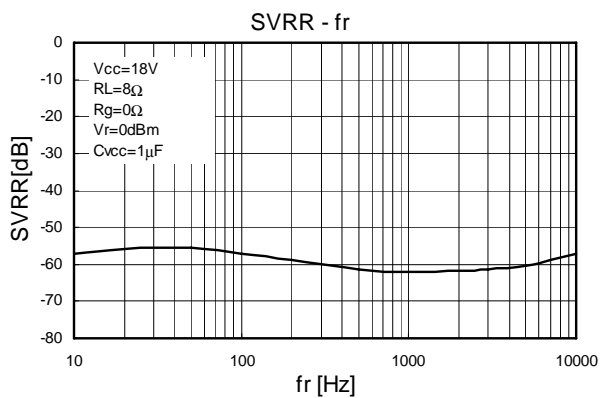
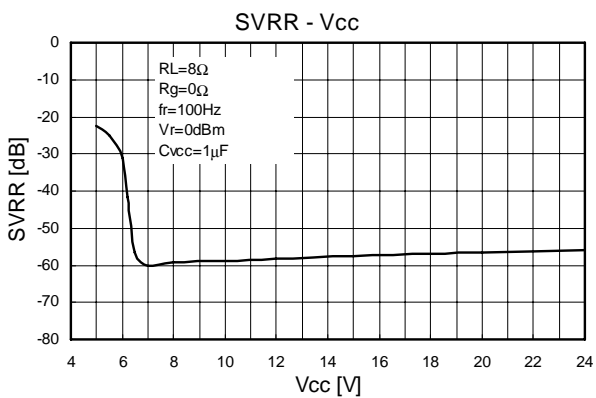
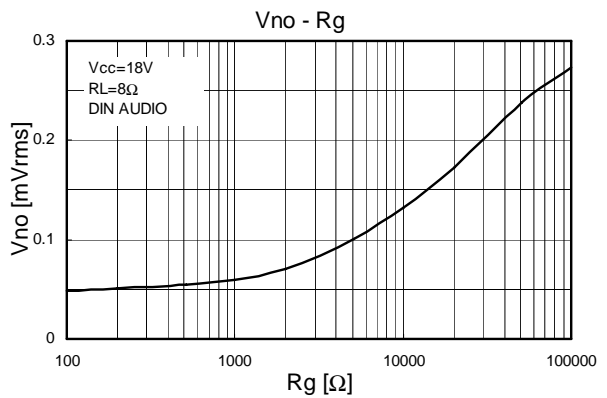
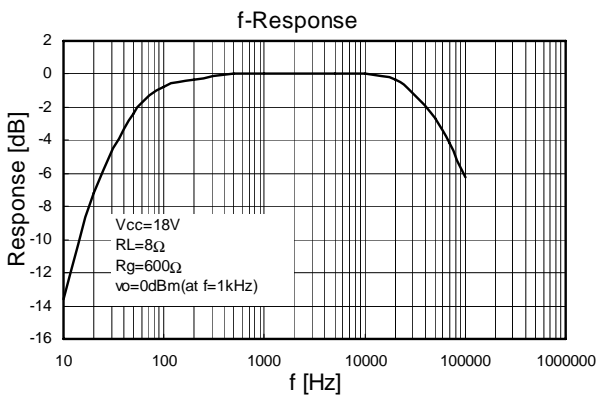
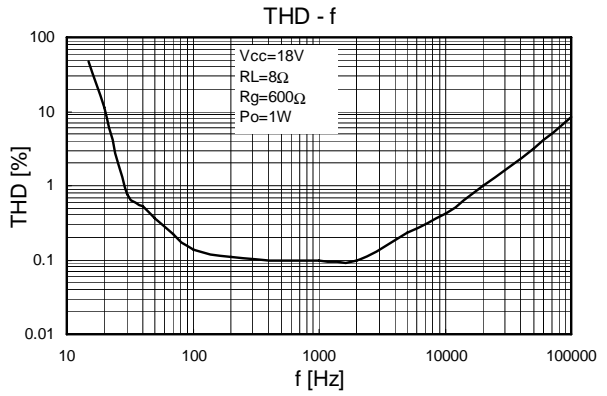
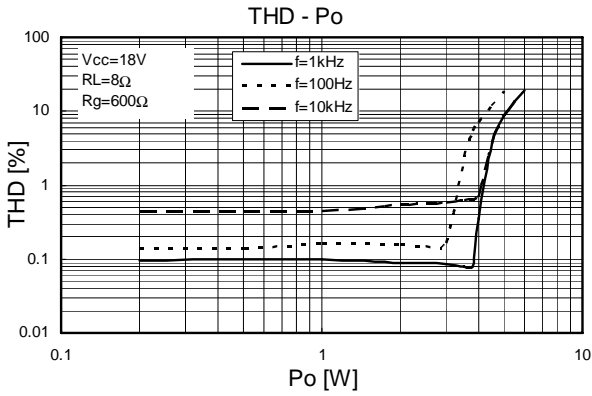
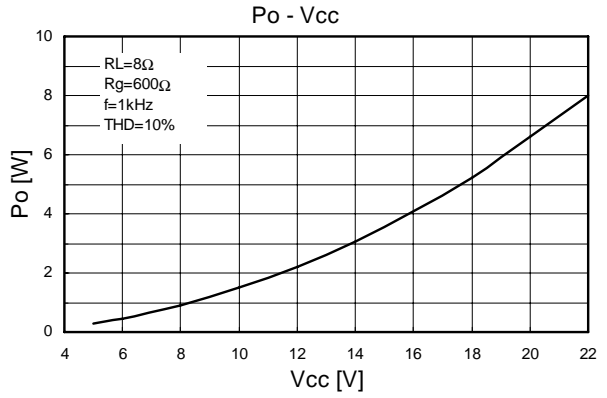
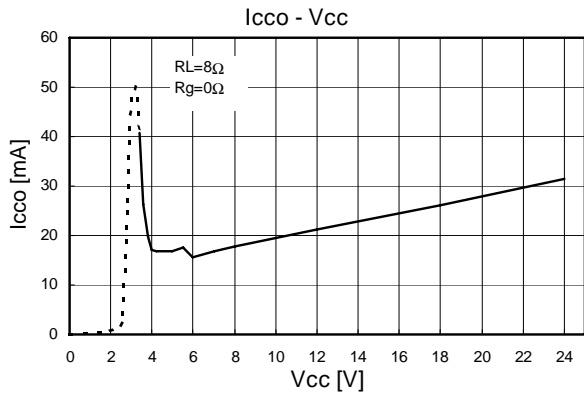

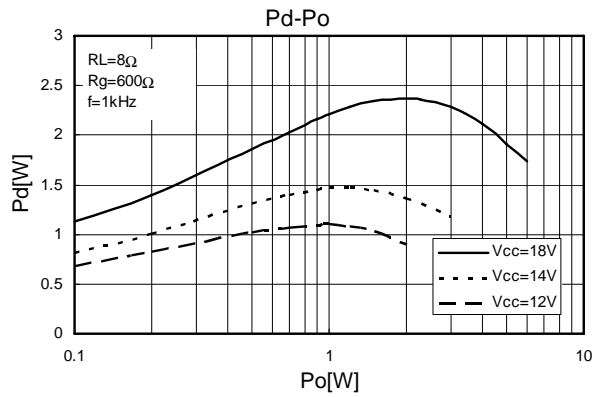
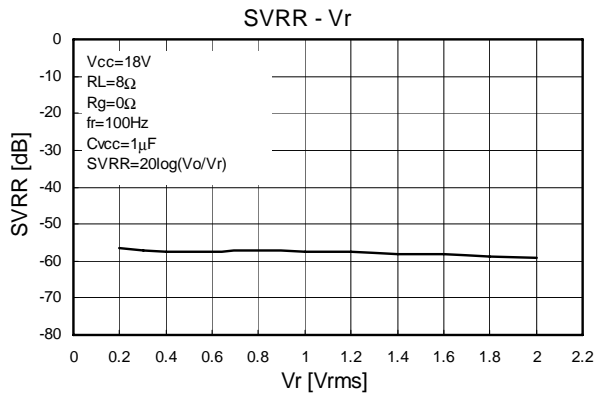

- SANYO Semiconductor Co.,Ltd. assumes no responsibility for equipment failures that result from using products at values that exceed, even momentarily, rated values (such as maximum ratings, operating condition ranges, or other parameters) listed in products specifications of any and all SANYO Semiconductor Co.,Ltd. products described or contained herein.
- SANYO Semiconductor Co.,Ltd. strives to supply high-quality high-reliability products, however, any and all semiconductor products fail or malfunction with some probability. It is possible that these probabilistic failures or malfunction could give rise to accidents or events that could endanger human lives, trouble that could give rise to smoke or fire, or accidents that could cause damage to other property. When designing equipment, adopt safety measures so that these kinds of accidents or events cannot occur. Such measures include but are not limited to protective circuits and error prevention circuits for safe design, redundant design, and structural design.
- In the event that any or all SANYO Semiconductor Co.,Ltd. products described or contained herein are controlled under any of applicable local export control laws and regulations, such products may require the export license from the authorities concerned in accordance with the above law.
- No part of this publication may be reproduced or transmitted in any form or by any means, electronic or mechanical, including photocopying and recording, or any information storage or retrieval system, or otherwise, without the prior written consent of SANYO Semiconductor Co.,Ltd.
- Any and all information described or contained herein are subject to change without notice due to product/technology improvement, etc. When designing equipment, refer to the "Delivery Specification" for the SANYO Semiconductor Co.,Ltd. product that you intend to use.
- Information (including circuit diagrams and circuit parameters) herein is for example only; it is not guaranteed for volume production.
- Upon using the technical information or products described herein, neither warranty nor license shall be granted with regard to intellectual property rights or any other rights of SANYO Semiconductor Co.,Ltd. or any third party. SANYO Semiconductor Co.,Ltd. shall not be liable for any claim or suits with regard to a third party's intellectual property rights which has resulted from the use of the technical information and products mentioned above.

This catalog provides information as of March, 2008. Specifications and information herein are subject to change without notice.